

Errata

Title & Document Type: 8340B Synthesized Sweeper Component Level Service Manual

Manual Part Number: 08340-90245

Revision Date: September 1987

HP References in this Manual

This manual may contain references to HP or Hewlett-Packard. Please note that Hewlett-Packard's former test and measurement, semiconductor products and chemical analysis businesses are now part of Agilent Technologies. We have made no changes to this manual copy. The HP XXXX referred to in this document is now the Agilent XXXX. For example, model number HP8648A is now model number Agilent 8648A.

About this Manual

We've added this manual to the Agilent website in an effort to help you support your product. This manual provides the best information we could find. It may be incomplete or contain dated information, and the scan quality may not be ideal. If we find a better copy in the future, we will add it to the Agilent website.

Support for Your Product

Agilent no longer sells or supports this product. You will find any other available product information on the Agilent Test & Measurement website:

www.tm.agilent.com

Search for the model number of this product, and the resulting product page will guide you to any available information. Our service centers may be able to perform calibration if no repair parts are needed, but no other support from Agilent is available.

HP 8340B SYNTHESIZED SWEEPER

10 MHz to 26.5 GHz

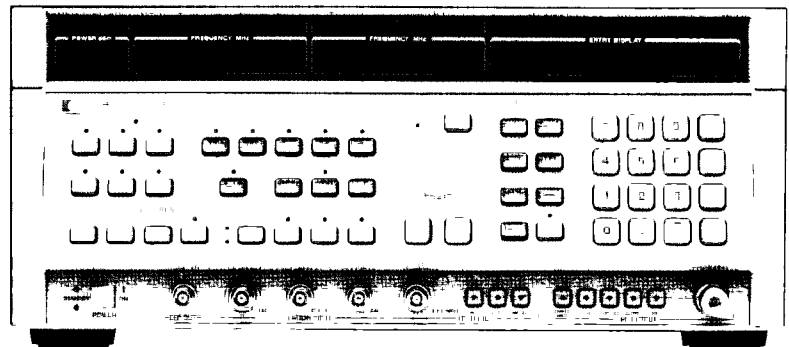

**HEWLETT
PACKARD**

**HP 8340B
SYNTHESIZED SWEEPER
(Including Options 001, 004,
005, 006, and 007)**

**Component Level Service Manual
Volume 1**

SERIAL NUMBERS

This manual applies directly to the HP 8340B Synthesized Sweeper having a serial number prefix of 2650A.

This manual also applies to the following serial number prefixes with exceptions as noted.

2624A - exception, A26 Linear Modulator Assembly. Refer to Service Note 8340B-1.

2634A - exception, FM input jack configuration, static protection diodes not added.

2643A - exception, A26 Linear Modulator Assembly, part number only.

For additional information about serial numbers, refer to INSTRUMENTS COVERED BY THE MANUAL in Section I of the HP 8340B/41B Operating Manual.

© Copyright HEWLETT-PACKARD COMPANY 1987
1400 FOUNTAINGROVE PARKWAY, SANTA ROSA, CA 95401 U.S.A.

MANUAL PART NO. 08340-90245
Microfiche Part Number 08340-90246

Printed: SEPTEMBER 1987



**HEWLETT
PACKARD**

Component-Level Service Volume 1

CONTENTS

SERVICE INTRODUCTION A

Direct I/O Addressing
After Service Safety Checks

REFERENCE LOOP – M/N LOOP B

A29 Reference Phase Detector
A30 100 MHz Voltage-Controlled Crystal Oscillator (VCXO)
A31 M/N Phase Detector
A32 M/N Voltage-Controlled Oscillator
A33 M/N Output
A34 Reference – M/N Motherboard

20/30 LOOPS C

A36 Phase Lock Loop 1 Voltage-Controlled Oscillator
A37 Phase Lock Loop 1 Divider
A38 Phase Lock Loop 1 IF
A39 Phase Lock Loop 3 Upconverter
A40 Phase Lock Loop 2 VCO
A41 Phase Lock Loop 2 Phase Detector
A42 Phase Lock Loop 2 Divider
A43 Phase Lock Loop 2 Discriminator

SWEEP GENERATOR/YO LOOP D

A23 FM Driver
A47 Sense Resistor Assembly
A48 YO Loop Sampler
A49 YO Loop Phase Detector
A50 YO Loop Interconnect
A54 YO Pretune/Delay Compensation
A55 YO Driver Assembly
A58 Sweep Generator

A62 MOTHERBOARD E

Motherboard Wiring List

Component-Level Service Introduction A

CONTENTS

INTRODUCTION

Read this First!	A-1
Section Purpose	A-1
Safety Considerations	A-2
Cleaning PC Board Finger Contacts	A-3
Printer Circuit Board Finger Cleaning Procedure	A-3

DIRECT I/O ADDRESSING

Description	A-4
Equipment Required	A-4
I/O Device Description	A-4
Strobe Verification	A-7
Input Register Verification	A-8
Digital-to-Analog Converter Verification	A-9
3-to-8 Decoder Verification	A-10

AFTER SERVICE SAFETY CHECKS

.....	A-13
-------	------

Component-Level Service Introduction

READ THIS FIRST!

This manual set assumes that you have used the assembly-level troubleshooting manual to isolate the failure to a specific assembly.

SECTION PURPOSE

Warnings and Cautions

This section provides warnings and cautions which should be followed when servicing this product.

Direct I/O Addressing

Direct I/O addressing is described in this section. This troubleshooting aid allows you to directly access and manipulate individual integrated circuits via the front panel keyboard.

SAFETY CONSIDERATIONS

GENERAL

This product and related documentation must be reviewed for familiarization with safety markings and instructions before operation. This product has been designed and tested in accordance with international standards.



The CAUTION sign denotes a hazard. It calls attention to an operating procedure, practice, or the like, which, if not correctly performed or adhered to, could result in damage to or destruction of part or all of the product. Do not proceed beyond a CAUTION sign until the indicated conditions are fully understood and met.

SAFETY SYMBOLS



Instruction manual symbol: the product will be marked with this symbol when it is necessary for the user to refer to the instruction manual (refer to Table of Contents).



Indicates hazardous voltages.



Indicates earth (ground) terminal.

WARNING

The WARNING sign denotes a hazard. It calls attention to a procedure, practice, or the like, which, if not correctly performed or adhered to, could result in personal injury. Do not proceed beyond a WARNING sign until the indicated conditions are fully understood and met.

BEFORE APPLYING POWER

Verify that the product is configured to match the available main power source per the input power configuration instructions provided in this manual.

If this product is to be energized via an auto-transformer make sure the common terminal is connected to the neutral (grounded side of the mains supply).

SERVICING

WARNING

Any servicing, adjustment, maintenance, or repair of this product must be performed only by qualified personnel.

Adjustments described in this manual may be performed with power supplied to the product while protective covers are removed. Energy available at many points may, if contacted, result in personal injury.

Capacitors inside this product may still be charged even when disconnected from their power source.

To avoid a fire hazard, only fuses with the required current rating and of the specified type (normal blow, time delay, etc.) are to be used for replacement.

CAUTION

DISCHARGING POWER SUPPLY CAPACITORS

Never short a capacitor with a screwdriver or similar direct short. Either wait for the capacitor to bleed off via normal instrument loads or, if this is not convenient, provide a discharge path by applying a 0.5 watt, 100 ohm resistor (via shielded clip leads) across the capacitor terminals.

STATIC SENSITIVE DEVICES

This product contains static sensitive components. Use an anti-static wrist strap when handling internal components or assemblies. Work on an anti-static surface. Never place internal assemblies on a work station that is covered static generating material.

THERMAL COMPOUND APPLICATION

Never use silicone-based thermal compound on internal components. Use of oil-based thermal compound is recommended.

NEVER CLEAN SOLDER FLUX FROM A PC BOARD

Solder flux contains caustic rosin activating acids. If the residual rosin is left on the board undisturbed, the activators remain encapsulated (and harmless), but attempts to clean the rosin off (by any means) releases the caustic rosin activators and spreads them over the PC board. These caustic chemicals get under the edges of the PC board traces.

In time, these chemicals react with the dissimilar metals in the trace (nickel, copper, gold) slowly dissolving the trace. They also create an electrical path between traces. This causes metal-ion migration, which leads to high impedance shorts and dendrite growth.

SOLDERING STATIONS

Use low-static solder removal tools when desoldering components. Only use soldering irons that have a grounded tip.

CLEANING PC BOARD FINGER CONTACTS

Use only the following method to clean PC Board fingers. NEVER clean fingers with an eraser. NEVER use tap water in the cleaning solution. Tap water contains chlorine. Chloride contamination from tap water, salt (from skin contact), can cause dendrite growth and trace damage. Always wear an anti-static ground strap when handling any internal component or assembly. Always hold printed circuit boards by the edges.

PRINTER CIRCUIT BOARD FINGER CLEANING PROCEDURE

Mix one part deionized water with two parts isopropyl alcohol. Apply this solution to a clean, lint free cloth (HP Part Number 9310-0039) or lint free tissue. Rub the printed circuit board finger contacts carefully, and dry with a clean portion of the cloth or tissue.

Direct I/O Addressing

DESCRIPTION

Direct I/O addressing is a diagnostic feature that allows you to directly access instrument input and output devices from the front panel and verify their operation.

You can only use direct I/O addressing after the instrument has passed self-test (CHECK LED I and II are off, see the controller functional group in the assembly-level service manual for more information). In addition, the front panel (or HP-IB) must be operational. Use I/O addressing when you have determined the signal path, and wish to test a specific I/O device.

EQUIPMENT REQUIRED

- DVM
- Logic Probe
- Extender Boards
- Jumper Wires
- Oscilloscope

I/O DEVICE DESCRIPTION

Output Devices

Output devices drive one or more lines, and consist of the HP-IB interface and output registers/buffers. To test output devices using direct I/O addressing, place a known state on the device's input and execute a "read" command. This causes the data to be placed on the data bus and then be displayed in the front panel ENTRY DISPLAY. This verifies that the device under test is working properly.

Input Devices

Input devices read data from one or more lines, and consist of DACs, decoders, and input registers. To test these devices using direct I/O addressing, place a known state on the data bus by executing a "write" command. Check the device's output with a logic probe, oscilloscope, or DVM to verify that the signal was accepted and the device responded properly.

Table A-1 lists all the devices that can be accessed by direct I/O addressing. The first two columns define the address (channel/subchannel) of the I/O strobe that must be generated to test the particular device. The third column gives the strobe's mnemonic. The fourth column lists the source mnemonic. The fifth column references the device being accessed (destination of the strobe). The last column shows if you can use direct I/O addressing to troubleshoot the specific device, or if you must use an alternate troubleshooting method.

Use the assembly schematic and the data in Table A-1 when using direct I/O addressing for troubleshooting. Column one and two contain the I/O channel and strobe subchannel numbers which are input to address a specific line on a device.

Schematics show the strobe address:

(x,Ry)

x is the I/O channel number

y is the strobe subchannel number

R is simply a notation that means "subchannel"

Component-Level Service Introduction

Table A-1. I/O Devices (1 of 3)

I/O Chn	Strobe Subchn	Mnemonic	From IC	Destination IC	Direct I/O Capability
0	0	LCK2	A59U26	A42U14	Yes
0	1	LCK3	A59U26	A43U9 A43U12	Yes Yes
0	2	LCK1	A59U26	A42U12 A42U13	Yes Yes
0	3	LCK4	A59U26	A36U5 A37U9 A37U10	Yes Yes Yes
1	0	WSPAT	A59U26	A58U27 A58U29 A58U31	Yes Yes Yes
1	1	WSPTM	A59U26	A58U23 A58U25 A58U26	Yes Yes Yes
1	2	WRDAC	A59U26	A58U4 A58U19 A58U21	Yes Yes Yes
1	3	LRSW	A59U26	A59U23	Yes
2	0	START TIMER	A59U19	A59U20	Yes
2	1	RESET TIMER	A59U19	A59U20	Yes
2	2	UNASSIGNED			
2	3	UNASSIGNED			
3	0	TYOKP	A59U26	A54U9	Yes
3	1	PHASE LOCK CNTRL	A59U26	A59U24	Yes
3	2	WPDAC	A59U26	A54U11 A54U13	Yes Yes
3	3	M/N OSC CONTROL	A59U26	A59U10 A59U17	Yes Yes
4	0	HP-IB ADDR	A59U12	A59U2	Yes
4	1	HP-IB READ	A59U12	A59U15 A59U16	See A59 Service Yes
4	2	HP-IB WRITE		A59U15	See A59 Service
4	3	READ STATUS	A59U12	A59U18	Yes
5	0	STOP PROCESSOR	A59U12	A59U4	Yes
5	1	WYOKW	A59U12	A54U9 A54U15	Yes
5	2	RESET PWR FAIL FF	A59U12	A59U4	No
5	3	WCDAC	A59U12	A54U16	Yes

Component-Level Service Introduction

Table A-1. I/O Devices (2 of 3)

I/O Chn	Strobe Subchn	Mnemonic	From IC	Destination IC	Direct I/O Capability
6	0	LEN4	A6U15	A6U16	See A6 Service
6	1	LEN5	A6U15	A6U6	See A6 Service
6	2	LEN6	A6U15	A6U13 A6U18 A6U19	See A6 Service
6	3	LEN7	A6U15	A6U11 A6U12	See A6 Service
7		UNASSIGNED			
8		UNASSIGNED			
9		UNASSIGNED			
10	0	WMOD	A27U27	A26U15	Yes
10	1	WLEVEL	A27U27	A24U15 A27U13 A27U16	Yes Yes Yes
10	2	WBAND	A27U27	A27U28 A28U14	Yes Yes
10	3	RLEVEL	A27U27	A27U11 A27U12 A27U15 A27U21	Yes Yes Yes Yes
11	0	WLSWP	A27U27	A27U23 A27U30	Yes Yes
11	1	WSYTMSLP	A27U27	A28U15	Yes
11	2	UNASSIGNED			
11	3	WSYTMCTL	A27U27	A28U13	Yes
12	0	WRITE RAM	A57U28	A57U2 A57U15 A57U29	See A57/A60 Service Yes
12	1	READ STS	A57U28	A57U24	Yes
12	2	READ RAM	A57U28	A57U8 A57U16 A57U29	See A57 Service Yes
12	3	WRITE ADR 3	A57U28	A57U1 A57U10	Yes Yes
13	0	TRIGGER SEL	A57U28	A57U18	Yes
13	1	WRITE STROBE	A57U28	A57U25	Yes
13	2	MAN DAC	A57U28	A57U9 A57U17	Yes
13	3	WRITE CONTROL	A57U28	A57U23	Yes
14	0	WATNS	A27U20	A27U8	Yes

Table A-1. I/O Devices (3 of 3)

I/O Chn	Strobe Subchn	Mnemonic	From IC	Destination IC	Direct I/O Capability
14	1	UNASSIGNED			
14	2	WBP1S	A27U20	A27U9	Yes
14	3	WBP2S	A27U20	A27U10	Yes
15	0	UNASSIGNED			
15	1	WADCC	A27U20	A27U29	Yes
15	2	UNASSIGNED			
15	3	RSTAT	A27U20	A24U14 A27U22	Yes Yes

STROBE VERIFICATION

Equipment Required

A logic probe or an oscilloscope.

Procedure

1. Switch the instrument to STANDBY and place the appropriate assembly on an extender board. Connect the logic probe to +5V and ground, then switch the instrument ON.
2. Press [INSTR PRESET] [MANUAL].
This prevents the processor from writing data to the device you are testing, and ensures that the data entered from the front panel is not changed prior to testing the device.
3. Press [SHIFT] [GHz] [X] [X] [Hz]
(XX is the channel number) to set up the I/O strobe channel.
4. Press [SHIFT] [MHz] [Y] [Y] [Hz]
(YY is the subchannel number) to set up the I/O strobe subchannel.
5. Press [SHIFT] [kHz]
To set up an I/O write that allows the strobe to be pulsed. Turn the front panel knob to cause the strobe to repeat.
6. Probe the appropriate pin and turn the front panel knob. Verify that the strobe is pulsed.

INPUT REGISTER VERIFICATION

Equipment Required

Use a logic probe, oscilloscope, or a DVM.

Procedure

1. Verify the operation of the output register's I/O strobe as described above.
2. Press: [INSTR PRESET] [MANUAL] Lockout processor
 [SHIFT] [GHz] [X] [X] [Hz] Enter XX Channel number
 [SHIFT] [MHz] [Y] [Y] [Hz] Enter YY Subchannel number
 [SHIFT] [kHz] Activate I/O write to device
3. Each input register has a number of data lines going to it. Refer to Table A-2 and look up the decimal equivalent of the least significant data input line (for example DB0). The table indicates that 1 is the decimal equivalent for DB0, so enter [1] [Hz] to set that input line high.
4. Examine the output lines using a logic probe, oscilloscope, or DVM. The output line corresponding to the DB0 input should be set true (i.e. if the device output is high = true, the output corresponding to DB0 should be high. If the device output is low = true, the output corresponding to DB0 should be low), all other lines should be in the opposite TTL state. Be sure to check all the other lines to eliminate the possibility of pin to pin shorts.
5. In Table A-2, look up the decimal equivalent of the next data line (in this example, the next line is DB1). The table shows a 2 is the decimal equivalent for DB1; enter [2] [Hz] to set that input line high.
6. Examine the output lines using a logic probe, oscilloscope, or DVM. The output line corresponding to the DB1 input should be set true, all other lines should be false.
7. Repeat steps 5 and 6 for each data line going to the device.

Table A-2. Direct I/O Data Bit Information

Decimal Values for Set Data Bits								
Data Line	0	1	2	3	4	5	6	7
Decimal Value	1	2	4	8	16	32	64	128
Data Line	8	9	10	11	12	13	14	15
Decimal Value	256	512	1024	2048	4096	8192	16384	32768

DIGITAL-TO-ANALOG CONVERTER VERIFICATION

Digital to Analog Converters (DACs) that can be tested using direct I/O addressing must be connected to the data bus and have a strobe listed in Table A-1. An example is A54U15, shown in figure A-1. Several other DACs have their data sent from an input register (e.g. A54U6). These DACs can be tested as described below, but all the addressing and data entry must be to the output register that precedes the DAC under test.

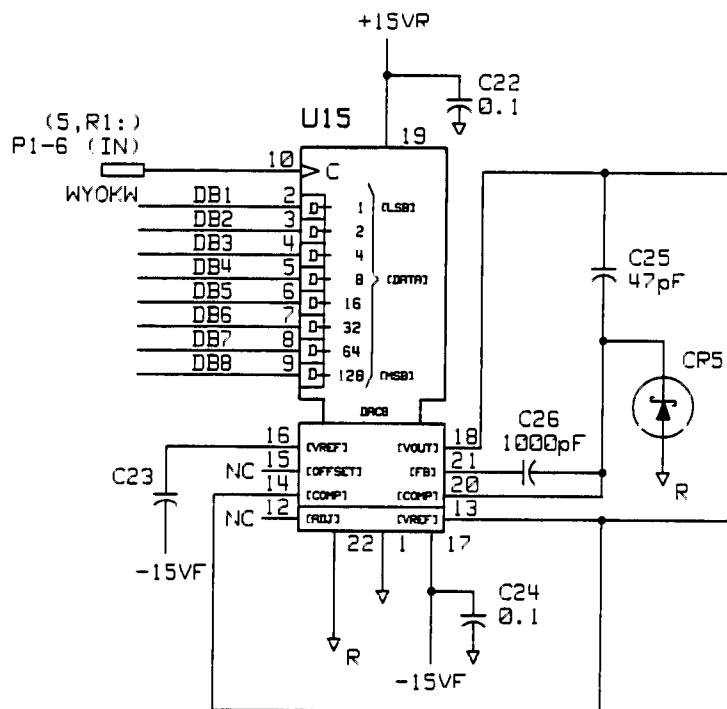

Figure A-1. DAC Example, A54U15.

Procedure

1. Verify the operation of the DAC's I/O strobe as described in the strobe verification procedure.
2. Press: **[INSTR PRESET] [MANUAL]** Lockout processor
[SHIFT] [GHz] [X] [X] [Hz] Enter XX Channel number
[SHIFT] [MHz] [Y] [Y] [Hz] Enter YY Subchannel number
[SHIFT] [kHz] Activate I/O write to device
[0] [Hz] Set all DAC input lines low
3. Connect a DVM to the output of the DAC and note the voltage reading. The measured voltage is the offset voltage associated with the DAC. (For current output DACs, the voltage measurements must be made at the output of the following current to voltage stage.)
4. Refer to Table A-2 for the decimal number that activates the DAC's least significant input. Enter this number via the ENTRY keyboard, and terminate the entry by pressing **[Hz]**.

5. Verify that the output of the DAC changes (note that the change caused by activating the least significant bit may be very small).
6. Repeat steps 4 and 5 for each of the data lines to the DAC.

3-TO-8 DECODER VERIFICATION

The 3 to 8 decoders that can be tested are limited to those that use the data bus lines for input. These do not include the decoders that use the address bus as an input. A58U34 is used as an example (see Figure A-2) in the following procedure.

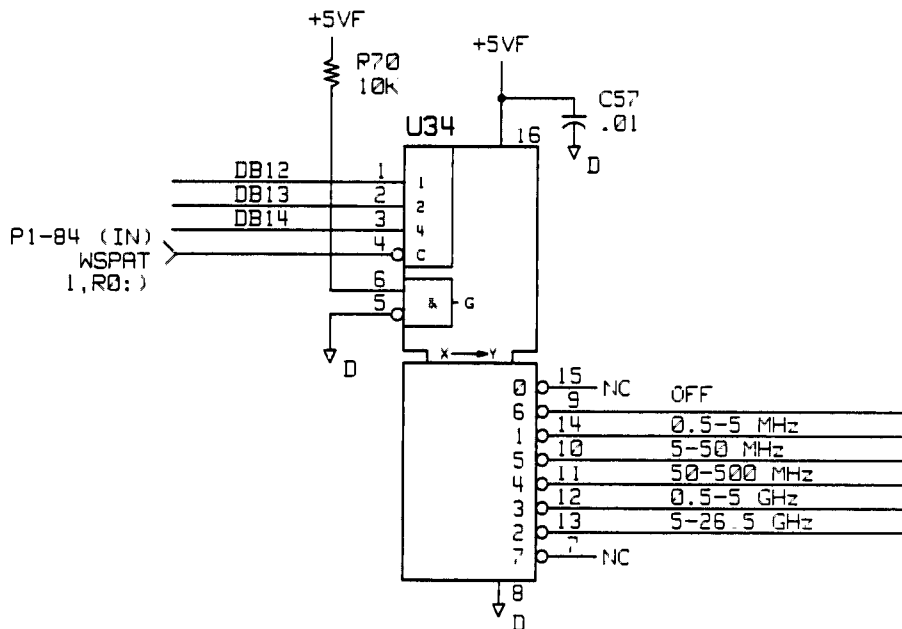

Figure A-2. 3 to 8 Decoder Example, A58U34

Procedure

1. Verify the operation of the device's I/O strobe as described in the strobe verification procedure.
2. Press: **[INSTR PRESET] [MANUAL]** Lockout processor
[SHIFT] [GHz] [X] [X] [Hz] Enter XX Channel number
[SHIFT] [MHz] [Y] [Y] [Hz] Enter YY Subchannel number
[SHIFT] [kHz]

3. As shown below, set the input to the decoder to zero and verify that only the "0" output line is set.
4. Set the input to one and verify that the "1" output is set.
5. Repeat this process to test all eight states (input states 0 through 7).

DB12, DB13, and DB14 are the three data bus inputs to A58U34. The three data lines must be set from 000 to 111 to verify the eight output states of the decoder.

Using A58U34 as an example:

- a. Set Decoder Output Line 0 Low:

Refer to Figure A-2. Place a binary number on input lines DB12 through DB14 to enable the corresponding output pin. The outputs are labeled 0 through 7. Place the binary number 4096 on the input lines (DB12=high, DB13=low, DB14=low) to cause output line 1 (pin 14) to go low. All other output lines should remain high.

NOTE: Setting data lines high can affect circuitry on the output of the decoder. Sometimes control lines can be affected which can change instrument state. In some cases this could change the data lines you just set.

Table A-2 shows the number to enter on the front panel to set any single data line high. If you want to set output 0 (pin 15) low, place a binary 0 on data lines DB12, 13, and 14. Enter [0] [Hz] from the front panel to set all data lines low. This will enable the "0" output pin 15, while all other output pins will remain high.

- b. Set Decoder Output Line 1 Low:

To set output 1 (pin 14) low, place a binary 1 on the input data lines. This can be done by setting DB12 high. Table A-2 shows that entering [4] [0] [9] [6] [Hz] (decimal value of data bit 12), will set DB12 high.

- c. Set Decoder Output Line 2 Low:

To set output 2 (pin 13) low, set data line DB13 high. Table A-2 shows that entering [8] [1] [9] [2] [Hz] will set DB13 high.

- d. Set Decoder Output Line 3 Low:

The next output line you must check is output 3 (pin 12). To do this, you must set data lines DB12 and DB13 high at the same time. Table A-2 shows that entering the number [4] [0] [9] [6] will set DB12 high, and entering [8] [1] [9] [2] will set DB13 high. To set both lines high, add the two numbers together and enter the sum into the front panel. ($4096 + 8192 = 12288$) [1] [2] [2] [8] [8] [Hz].

- e. Continue Until All Lines Are Checked:

Table A-3 shows the values required to set all output lines in sequence. Starting with line 4, enter values into the front panel and verify the proper operation of each output line.

Component-Level Service Introduction

Table A-3. A58U34 Truth Table

DB14	DB13	DB12	Decimal Input	Decoder Output
0	0	0	0	0
0	0	1	4096	1
0	1	0	8192	2
0	1	1	12288	3
1	0	0	16384	4
1	0	1	20480	5
1	1	0	24576	6
1	1	1	28672	7

After Service Safety Checks

Visually inspect the interior of the instrument for any signs of internally generated heat, such as discolored printed circuit boards or components, damaged insulation, or evidence of arcing. Determine and remedy the cause of any such condition.

Using an ohmmeter, check the resistance from the instrument enclosure to the ground pin on the power cord plug. The reading must be less than 1Ω . Flex the power cord while making this measurement to check for intermittent conditions.

Check the resistance from the instrument enclosure to the line and neutral (tied together) with the line switch on and ac mains disconnected. The minimum acceptable resistance is $2\text{ M}\Omega$.

If the instrument does not pass either of the above tests, **DO NOT PLUG IN THE INSTRUMENT.** Troubleshoot the source of the problem at once.

Check the line fuse to verify that a correctly rated fuse is installed. Make sure the line module's voltage selector wheel is set to the correct voltage.

Reference Loop – M/N Loop Component-Level Service B

CONTENTS

A29 REFERENCE PHASE DETECTOR

CIRCUIT DESCRIPTION	A29-1
Assembly Purpose	A29-1
Limiting Amplifier (Block A)	A29-1
Pulse Generator (Block B)	A29-1
Phase Lock Sampler (Block D)	A29-1
Integrating Amplifier (Block E)	A29-1
VCXO Divider and Buffers (Block F)	A29-1
Forty-Five Degree Phase Lead Amplifier (Block G), Forty-Five Degree Phase Lag Amplifier (Block H)	A29-2
Lock Indicator Sampler (Block I)	A29-2
Phase Lock Detector (Block J)	A29-2
TROUBLESHOOTING	A29-3
Introduction	A29-3
Samplers (Block D and Block I)	A29-3
Forty-Five Degree Phase Lead Amplifier (Block G), Forty-Five Degree Phase Lag Amplifier (Block H)	A29-3
Limiting Amplifier (Block A)	A29-4
Pulse Generator (Block B)	A29-4
Buffer Amplifier (Block C)	A29-6
Integrating Amplifier (Block E)	A29-6
Phase Lock Detector (Block J)	A29-7
A29 Reference Phase Detector Pin I/O	A29-7
A29 Reference Phase Detector Component Location Diagram	A29-8
A29 Reference Phase Detector Schematic Diagram	A29-9
A29 Reference Phase Detector Replaceable Parts	A29-11

A30 100 MHZ VOLTAGE-CONTROLLED CRYSTAL OSCILLATOR (VCXO)

CIRCUIT DESCRIPTION	A30-1
Assembly Purpose	A30-1
100 MHz Oscillator (Block A)	A30-1
100 MHz Buffer Amplifier (Block B)	A30-1
Quadrupler (Block C)	A30-2
400 MHz Amplifier (Block D)	A30-2
Power Supplies (Block E)	A30-2
TROUBLESHOOTING	A30-3
100 MHz Oscillator (Block A)	A30-3
100 MHz Buffer Amplifiers (Block B)	A30-3
Quadrupler (Block C), 400 MHz Amplifier (Block D)	A30-4
A30 100 MHz VCXO Pin I/O	A30-5
A30 100 MHz VCXO Component Location Diagram	A30-6
A30 100 MHz VCXO Schematic Diagram	A30-7
A30 100 MHz VCXO Replaceable Parts	A30-9

CONTENTS (Cont'd)

A31 M/N PHASE DETECTOR

CIRCUIT DESCRIPTION	A31-1
Assembly Purpose	A31-1
TTL ECL Level Translators (Block A)	A31-1
N Divider (Block B), M Divider (Block C)	A31-1
Mixer (Block D)	A31-5
IF Amplifier (Block E)	A31-5
Phase/Frequency Detector (Block F)	A31-5
Preamplifier (Block G)	A31-5
Phase Lock Indicator (Block H)	A31-5
TROUBLESHOOTING	A31-6
Introduction	A31-6
M Divider (Block B), N Divider (Block C)	A31-6
Mixer (Block D), IF Amplifier (Block E)	A31-10
Phase/Frequency Detector (Block F), Preamplifier (Block G)	A31-10
Phase Lock Detector (Block H)	A31-11
A31 M/N Phase Detector Pin I/O	A31-11
A31 M/N Phase Detector Component Location Diagram	A31-12
A31 M/N Phase Detector Schematic Diagram	A31-13
A31 M/N Phase Detector Replaceable Parts	A31-15

A32 M/N VOLTAGE-CONTROLLED OSCILLATOR

CIRCUIT DESCRIPTION	A32-1
Assembly Purpose	A32-1
A32A2 Voltage-Controlled Oscillator (Block A)	A32-1
A32A1 Buffer Amplifier (Block B)	A32-1
TROUBLESHOOTING	A32-2
Voltage Controlled Oscillator (Block A)	A32-2
Buffer Amplifier (Block B)	A32-2

A33 M/N OUTPUT

CIRCUIT DESCRIPTION	A33-1
Assembly Purpose	A33-1
Loop Amplifier (Block A)	A33-1
LO Output Amplifier (Block B)	A33-1
LO Amplifier (Block C)	A33-1
Divide-by-2 (Block D)	A33-1
M/N Output Amplifier (Block E)	A33-1
TROUBLESHOOTING	A33-2
Introduction	A33-2
Loop Amplifier (Block A)	A33-2
LO Amplifier (Block B)	A33-2
LO Amplifier (Block C), M/N Output Amplifier (Block E)	A33-3
A33 M/N Output Pin I/O	A33-3
A32 M/N VCO and A33 M/N Output Assembly Component Location Diagram	A33-4
A32 M/N VCO and A33 M/N Output Schematic Diagram	A33-5
A32 M/N VCO Replaceable Parts	A33-7
A33 M/N Output Replaceable Parts	A33-9

CONTENTS (Cont'd)

A34 REFERENCE – M/N MOTHERBOARD

TRUBLESHOOTING	A34-1
A34 Reference – M/N Motherboard P1 Pin I/O	A34-1
A34 Reference – M/N Motherboard P2	A34-1
A34 Reference – M/N Motherboard Component Location Diagram	A34-3
A34 Reference – M/N Motherboard Schematic Diagram	A34-5
A34 Reference Loop – M/N Motherboard Replaceable Parts	A34-7

A29 Reference Phase Detector Circuit Description

ASSEMBLY PURPOSE

The A29 reference phase detector has the 100 MHz reference phase-locked loop, VCXO (voltage-controlled oscillator) divider, phase lock detector, and integrating amplifier. 100 MHz from the A30 VCXO is divided by ten and then compared to the 10 MHz frequency standard. The error voltage from this comparison is fed back to the VCXO to keep its frequency locked to ten times that of the frequency standard. The reference phase-locked loop bandwidth is 100 Hz; the 10 MHz derived from the 100 MHz VCXO must be within ± 100 Hz of the 10 MHz frequency standard for the loop to lock reliably.

LIMITING AMPLIFIER (BLOCK A)

In this block, the 10 MHz signal from the frequency standard is amplified and amplitude limited.

PULSE GENERATOR (BLOCK B)

In this block, the 10 MHz signal is further limited to form a well shaped square wave and the proper logic levels are set for the buffer amplifier.

PHASE LOCK SAMPLER (BLOCK D)

The phase lock sampler acts as a phase detector. The 10 MHz pulses from the buffer amplifier are applied to the transformer primary. The divided-by-10 VCXO frequency is sampled and stored. When the loop is locked, the feedback due to the complete phase-locked loop forces the sampled voltage to be nearly zero. When the loop is unlocked, this voltage may be zero or varying, depending on the reason for unlock.

INTEGRATING AMPLIFIER (BLOCK E)

This is a high gain, linear integrating amplifier.

VCXO DIVIDER AND BUFFERS (BLOCK F)

A 100 MHz signal from the A30 VCXO assembly is divided by five, and then by two. Two of the resulting outputs (one of the 10 MHz outputs and the 20 MHz output) are buffered, to be used as reference frequencies by other assemblies in the instrument. The other 10 MHz output is used to drive the phase lock sampler (block D), and the lock indicator sampler (block I).

FORTY-FIVE DEGREE PHASE LEAD AMPLIFIER (BLOCK G)
FORTY-FIVE DEGREE PHASE LAG AMPLIFIER (BLOCK H)

The 45 degree phase shift buffers provide two 10 MHz signals that are 90 degrees apart in phase. The purpose of these signals is explained in the lock indicator sampler description (block I).

LOCK INDICATOR SAMPLER (BLOCK I)

The lock indicator sampler functions the same as the phase lock sampler (block D). The only difference is that the 10 MHz is 90 degrees shifted in phase. This causes the output of the lock indicator sampler to be a maximum negative voltage when the loop is locked.

PHASE LOCK DETECTOR (BLOCK J)

The output of the lock indicator sampler is compared to $-0.5V$. When the output voltage becomes closer to 0 than to $-0.5V$, the output goes to TTL high, indicating to the A59 digital interface assembly that the loop is unlocked.

A29 Reference Phase Detector Component-Level Troubleshooting

INTRODUCTION

The A29 Reference phase detector compares the output of the 10 MHz frequency standard to the output of the A30 100 MHz VCXO. A phase lock detector in the A29 assembly indicates to the A60 microprocessor the state of the reference phase lock loop.

SAMPLERS (BLOCK D and BLOCK I)

The phase lock and lock indicator samplers are identical. The diodes are biased to approximate the same level in each. The dc bias on the diodes is shown in Table A29-1

Table A29-1. Sampler Diode Bias Voltage Levels

Diode	dc Bias
CR3 Anode	+1.87V
CR4 Cathode	-1.92V
CR5 Cathode	-1.92V
CR6 Anode	+1.82V

The phase lock sampler output (the junction of R32 and R34) is 0V when locked or with no 10 MHz reference, and approximately +0.1V with no 100 MHz input. The lock indicator output (the junction of R25 and R23) is -1.5V when locked, 0V with no 10 MHz reference, and approximately +0.2V with no 100 MHz input.

FORTY-FIVE DEGREE PHASE LEAD AMPLIFIER (BLOCK G) FORTY-FIVE DEGREE PHASE LAG AMPLIFIER (BLOCK H)

The phase amplifiers shift the 100 MHz VCXO signal, which has been divided by 10 by U3, +45° and -45° respectively. Figure A29-1 shows typical waveforms at the collectors of Q1 and Q2. The dc voltages for Q1 and Q2 are shown in Table A29-2.

Table A29-2. Phase Amplifier Voltage Levels

	Voltage Levels	
	Q1	Q2
Emitter	-8.0V	-8.0V
Base	-7.4V	-7.4V
Collector	-3.6V	-3.6V

Oscilloscope Settings:

Vertical: 1V/Div Channel A: 1V/Div
 Horizontal: 0.05µsec/Div Channel B: 1V/Div
 Probes: 10:1

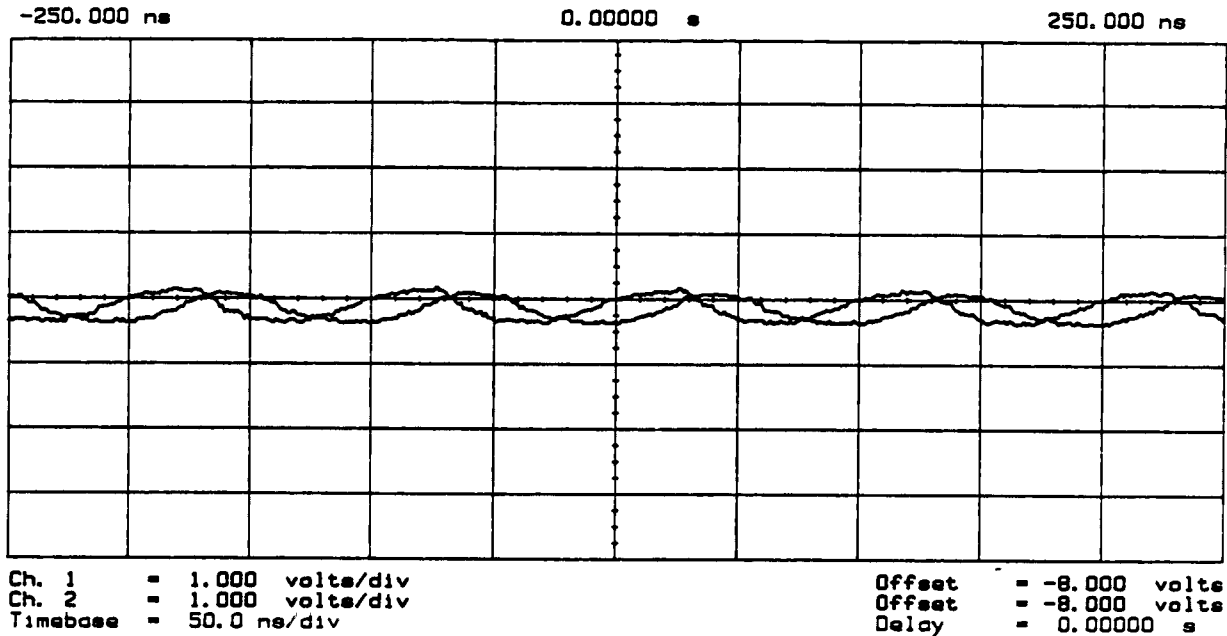

Figure A29-1. Outputs of 45° Phase Amplifiers

LIMITING AMPLIFIER (BLOCK A)

The limiting amplifier shapes and amplifies the 10 MHz reference from the frequency standard (A51). Typical voltage levels for U1 are shown in Table A29-3.

Table A29-3. Limiting Amplifier Voltage Levels

U1 Pin No.	dc Voltage Level
1	+5.0V
2	0V
3	+0.5V
4	0V
5	+2.3V
6	+2.3V
7	+1.6V
8	+5.0V

PULSE GENERATOR (BLOCK B)

Typical pulse generator input/output waveforms are shown in Figures A29-2 and Figure A29-3

Oscilloscope Settings:
 Vertical: 2V/Div
 Horizontal: 0.2 μ sec/Div
 X10 Magnifier

Channel A: U2B Pin 5
 Channel B: U2A Pin 2
 Probes: 10:1

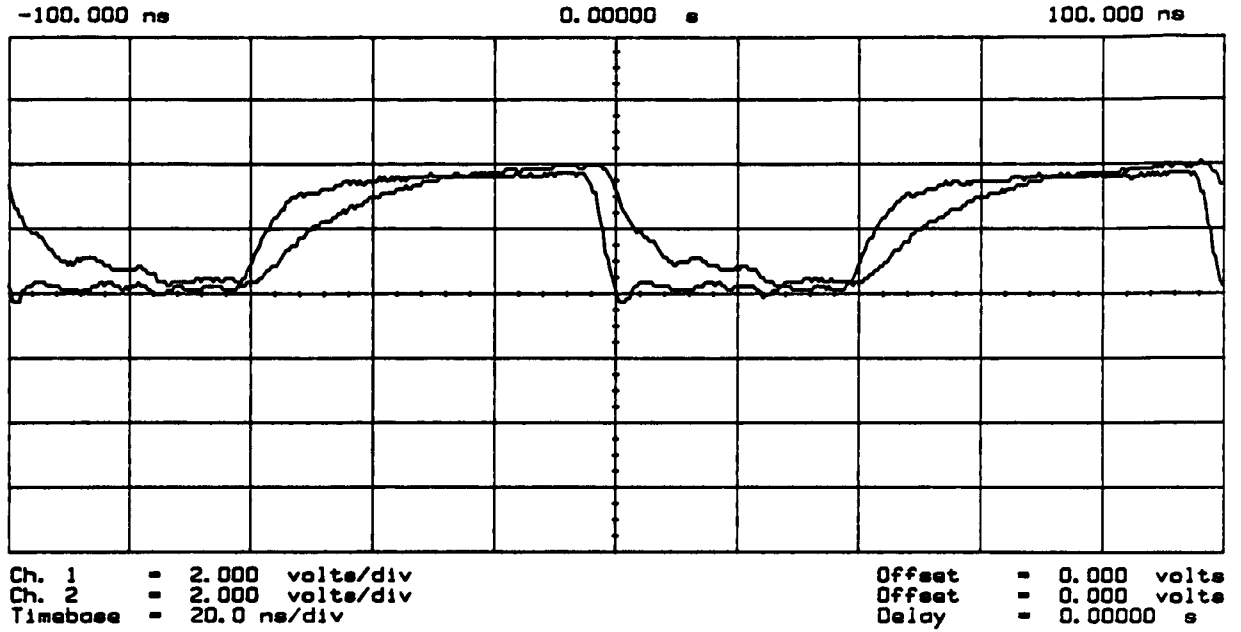

Figure A29-2. Pulse Generator Input Waveforms

Oscilloscope Settings:
 Vertical: 2V/Div
 Horizontal: 0.05 μ sec/Div
 Channel A: U2B Pin 4 (TP1)

Probe 10:1

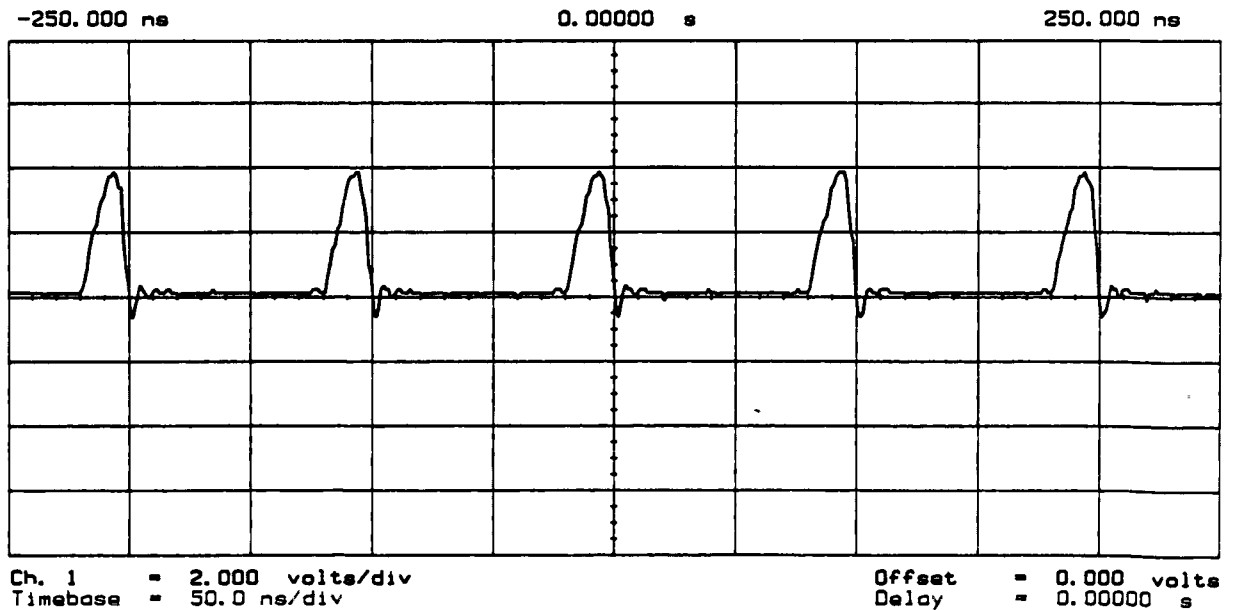

Figure A29-3. Pulse Generator Output Pulses

BUFFER AMPLIFIER (BLOCK C)

Typical buffer amplifier voltage levels are shown in Table A29-4:

Table A29-4. Buffer Amplifier Voltage Levels

	Voltage Levels	
	Q3	Q7
	Emitter	-4.6V
Base	-4.5V	-4.5V
Collector	-0.3V	-9.4V

INTEGRATING AMPLIFIER (BLOCK E)

Typical integrating amplifier voltage levels are shown in Table A29-5:

Table A29-5. Integrating Amplifier Voltage Levels

Transistor	dc Voltage Levels
Q4A Pin 1 Pin 2 Pin 3	+0.9V +9.8V 0.0V (locked) 0.0V (no 10 MHz) +0.1V (no 100 MHz)
Q4B Pin 4 Pin 5 Pin 6	+0.9V +9.8V 0.0V
Q5 Emitter Base Collector	+10.3V +9.8V GND
Q6 Emitter Base Collector	+10.3V +9.8V -2.2V

Integrating amplifier tune voltage output (the junction of R75 and R51):

- 8.6V (locked)
- 23.6V (unlocked with no 10 MHz)
- 1.4V (unlocked with no 100 MHz)

NOTE: You can measure the tune voltage at A29TP1, but the voltage levels are more positive.

PHASE LOCK DETECTOR (BLOCK J)

The output of the lock indicator sampler is compared to a reference of $-0.5V$ by comparator U5. The output of U5 is high for any unlocked condition. VR1 limits the output voltage (HULR) to approximately $+4.64V$.

Table A29-6. A29 Reference Phase Detector Pin I/O

Pin	Mnemonic	Levels	Source	Destination
1	-10V	-10V	XA34P2-8, 9	*K
2	-40V	-40V	XA34P2-6, 7	*K
3	GND	0V	INSTRUMENT GROUND	*K
4	GND	0V	INSTRUMENT GROUND	*K
5	+20V	+20V	XA34P2-2, 3	*K
6	GND	0V	INSTRUMENT GROUND	*K
7	HULR	TTL (HIGH TRUE)	J	XA34P2-14
8	GND	0V	INSTRUMENT GROUND	*K
9	-5.2V	-5.2V	XA34P2-12, 13	*K
10	GND	0V	INSTRUMENT GROUND	*K
11	GND	0V	INSTRUMENT GROUND	*K
12	TUNE GROUND	0V	E	XA30P1-12
13	TUNE VOLTAGE		E	XA30P1-14
14	GND	0V	INSTRUMENT GROUND	*K
15	GND	0V	INSTRUMENT GROUND	*K

A single letter in the source or destination column refers to a function block on this assembly schematic.

An asterisk (*) denotes multiple sources or destinations; refer to the A34 Reference Loop - M/N Motherboard Schematic Diagram for a complete representation of signal sources and destinations.

A29 Reference Phase Detector Component-Level Troubleshooting

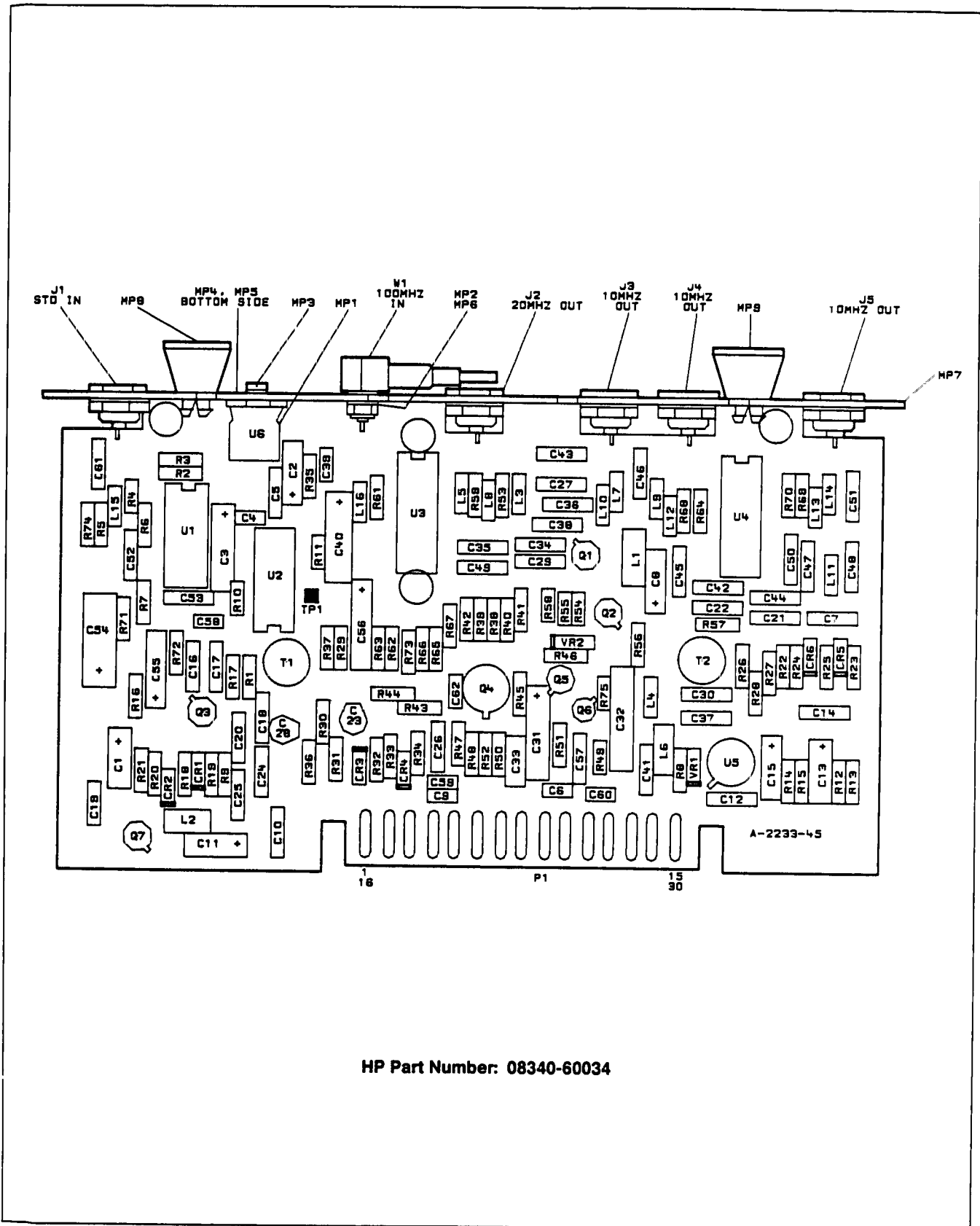
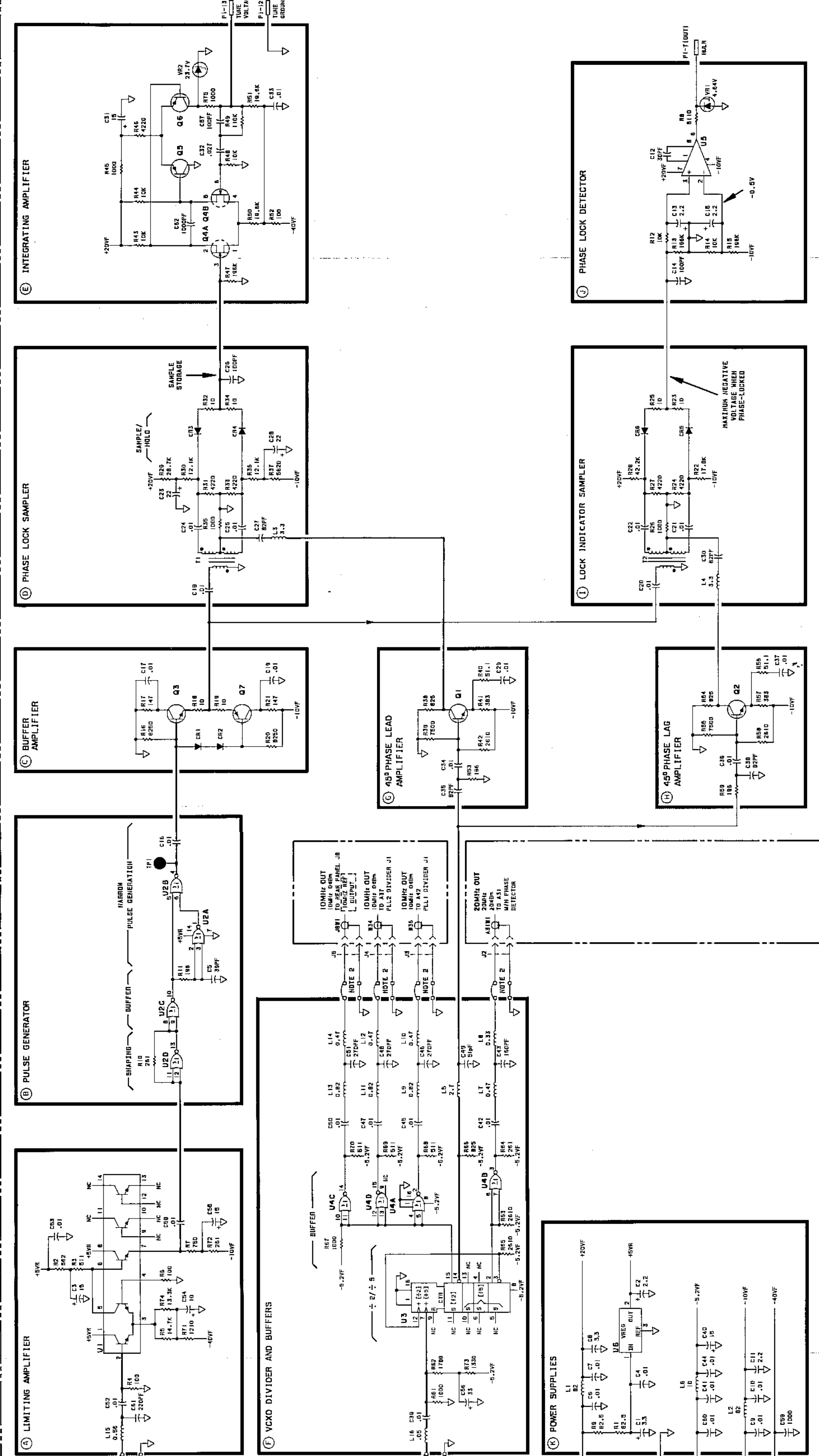

Figure A29-4. A29 Reference Phase Detector Component Location Diagram

A29 REFERENCE PHASE DETECTOR
OB340-80034



NOTES:
1. RESISTANCE VALUES SHOWN ARE IN OHMS, CAPACITANCE IN MICROFARADS, UNLESS OTHERWISE NOTED.
2. J1-15 AND A29W1 CENTER CONDUCTORS ARE ELECTRICALLY CONNECTED TO THE WAREHOUSE COVER PLATE. CONDUCTORS ARE ELECTRICALLY CONNECTED TO THE WAREHOUSE COVER PLATE. CONDUCTORS ARE ELECTRICALLY CONNECTED TO THE WAREHOUSE COVER PLATE. CONDUCTORS ARE ELECTRICALLY CONNECTED TO THE WAREHOUSE COVER PLATE.

Figure A29-5. A29 Reference Phase Detector, Schematic Diagram
Reference Loop - M/N Loop A29-5/A29-10

A29 Reference Phase Detector Component-Level Troubleshooting

Table A29-7. A29 Reference Phase Detector Replaceable Parts

Reference Designation	HP Part Number	C D	Qty	Description	Mfr Code	Mfr Part Number
A29	08340-60034	9	1	REFERENCE PHASE DETECTOR	28480	08340-60034
A29C1	0180-2141	6	2	CAPACITOR-FXD 3 3UF ± 10% 50VDC TA	04200	150D335X905082
A29C2	0180-0197	8	5	CAPACITOR-FXD 2 2UF ± 10% 20VDC TA	56289	150D225X9020A2
A29C3	0180-1746	5	4	CAPACITOR-FXD 15UF ± 10% 20VDC TA	56289	150D156X9020B2
A29C4	0160-3879	7	6	CAPACITOR-FXD 01UF ± 20% 100VDC CER	28480	0160-3879
A29C5	0140-0190	7	1	CAPACITOR-FXD 39PF ± 5% 300VDC MICA	72136	DM15E390J0300WV1CR
A29C6	0160-3879	7		CAPACITOR-FXD 01UF ± 20% 100VDC CER	28480	0160-3879
A29C7	0160-2055	9	24	CAPACITOR-FXD 01UF + 80-20% 100VDC CER	28480	0160-2055
A29C8	0180-2141	6		CAPACITOR-FXD 3 3UF ± 10% 50VDC TA	04200	150D335X905082
A29C9	0160-3879	7		CAPACITOR-FXD 01UF ± 20% 100VDC CER	28480	0160-3879
A29C10	0160-2055	9		CAPACITOR-FXD 01UF + 80-20% 100VDC CER	28480	0160-2055
A29C11	0180-0197	8		CAPACITOR-FXD 2 2UF ± 10% 20VDC TA	56289	150D225X9020A2
A29C12	0180-2199	2	1	CAPACITOR-FXD 30PF ± 5% 300VDC MICA	28480	0160-2199
A29C13	0180-0197	8		CAPACITOR-FXD 2 2UF ± 10% 20VDC TA	56289	150D225X9020A2
A29C14	0160-2204	0	3	CAPACITOR-FXD 100PF ± 5% 300VDC MICA	28480	0160-2204
A29C15	0180-0197	8		CAPACITOR-FXD 2 2UF ± 10% 20VDC TA	56289	150D225X9020A2
A29C16	0160-2055	9		CAPACITOR-FXD 01UF + 80-20% 100VDC CER	28480	0160-2055
A29C17	0160-2055	9		CAPACITOR-FXD 01UF + 80-20% 100VDC CER	28480	0160-2055
A29C18	0160-2055	9		CAPACITOR-FXD 01UF + 80-20% 100VDC CER	28480	0160-2055
A29C19	0160-2055	9		CAPACITOR-FXD 01UF + 80-20% 100VDC CER	28480	0160-2055
A29C20	0160-2055	9		CAPACITOR-FXD 01UF + 80-20% 100VDC CER	28480	0160-2055
A29C21	0160-2055	9		CAPACITOR-FXD 01UF + 80-20% 100VDC CER	28480	0160-2055
A29C22	0160-2055	9		CAPACITOR-FXD 01UF + 80-20% 100VDC CER	28480	0160-2055
A29C23	0180-0553	0	2	CAPACITOR-FXD 22UF ± 20% 25VDC TA	28480	0180-0553
A29C24	0160-2055	9		CAPACITOR-FXD 01UF + 80-20% 100VDC CER	28480	0160-2055
A29C25	0160-2055	9		CAPACITOR-FXD 01UF + 80-20% 100VDC CER	28480	0160-2055
A29C26	0160-2204	0		CAPACITOR-FXD 100PF ± 5% 300VDC MICA	28480	0160-2204
A29C27	0140-0193	0	4	CAPACITOR-FXD 82PF ± 5% 300VDC MICA	72136	DM15E820J0300WV1CR
A29C28	0180-0553	0		CAPACITOR-FXD 22UF ± 20% 25VDC TA	28480	0180-0553
A29C29	0160-2055	9		CAPACITOR-FXD 01UF + 80-20% 100VDC CER	28480	0160-2055
A29C30	0140-0193	0		CAPACITOR-FXD 82PF ± 5% 300VDC MICA	72136	DM15E820J0300WV1CR
A29C31	0180-1746	5		CAPACITOR-FXD 15UF ± 10% 20VDC TA	56289	150D156X9020B2
A29C32	0170-0066	9	1	CAPACITOR-FXD 027UF ± 10% 200VDC POLYE	28480	0170-0066
A29C33	0160-2055	9		CAPACITOR-FXD 01UF + 80-20% 100VDC CER	28480	0160-2055
A29C34	0160-2055	9		CAPACITOR-FXD 01UF + 80-20% 100VDC CER	28480	0160-2055
A29C35	0140-0193	0		CAPACITOR-FXD 82PF ± 5% 300VDC MICA	72136	DM15E820J0300WV1CR
A29C36	0160-2055	9		CAPACITOR-FXD 01UF + 80-20% 100VDC CER	28480	0160-2055
A29C37	0160-2055	9		CAPACITOR-FXD 01UF + 80-20% 100VDC CER	28480	0160-2055
A29C38	0140-0193	0		CAPACITOR-FXD 82PF ± 5% 300VDC MICA	72136	DM15E820J0300WV1CR
A29C39	0160-3879	7		CAPACITOR-FXD 01UF ± 20% 100VDC CER	28480	0160-3879
A29C40	0180-1746	5		CAPACITOR-FXD 15UF ± 10% 20VDC TA	56289	150D156X9020B2
A29C41	0160-2055	9		CAPACITOR-FXD 01UF + 80-20% 100VDC CER	28480	0160-2055
A29C42	0160-2055	9		CAPACITOR-FXD 01UF + 80-20% 100VDC CER	28480	0160-2055
A29C43	0160-2206	2	1	CAPACITOR-FXD 160PF ± 5% 300VDC MICA	28480	0160-2206
A29C44	0160-2055	9		CAPACITOR-FXD 01UF + 80-20% 100VDC CER	28480	0160-2055
A29C45	0160-2055	9		CAPACITOR-FXD 01UF + 80-20% 100VDC CER	28480	0160-2055
A29C46	0140-0210	2	3	CAPACITOR-FXD 270PF ± 5% 300VDC MICA	72136	DM15F271J0300WV1CR
A29C47	0160-2055	9		CAPACITOR-FXD 01UF + 80-20% 100VDC CER	28480	0160-2055
A29C48	0140-0210	2		CAPACITOR-FXD 270PF ± 5% 300VDC MICA	72136	DM15F271J0300WV1CR
A29C49	0160-2201	7	1	CAPACITOR-FXD 51PF ± 5% 300VDC MICA	28480	0160-2201
A29C50	0160-2055	9		CAPACITOR-FXD 01UF + 80-20% 100VDC CER	28480	0160-2055
A29C51	0140-0210	2		CAPACITOR-FXD 270PF ± 5% 300VDC MICA	72136	DM15F271J0300WV1CR
A29C52	0160-2055	9		CAPACITOR-FXD 01UF + 80-20% 100VDC CER	28480	0160-2055
A29C53	0160-2055	9		CAPACITOR-FXD 01UF + 80-20% 100VDC CER	28480	0160-2055
A29C54	0180-0183	2	1	CAPACITOR-FXD 10UF + 75-10% 50VDC AL	56289	30D106G050CB2
A29C55	0180-1746	5		CAPACITOR-FXD 15UF ± 10% 20VDC TA	56289	150D156X9020B2

A29 Reference Phase Detector Component-Level Troubleshooting

Table A29-7. A29 Reference Phase Detector Replaceable Parts

Reference Designation	HP Part Number	C	D	Qty	Description	Mfr Code	Mfr Part Number
A29C56	0180-0229	7	1		CAPACITOR-FXD 33UF ± 10% 10VDC TA	56289	150D336X9010B2
A29C57	0160-2204	0			CAPACITOR-FXD 100PF ± 5% 300VDC MICA	28480	0160-2204
A29C58	0160-3879	7			CAPACITOR-FXD 01UF ± 20% 100VDC CER	28480	0160-3879
A29C59	0160-3878	6	2		CAPACITOR-FXD 1000PF ± 20% 100VDC CER	28480	0160-3878
A29C60	0160-3879	7			CAPACITOR-FXD 01UF ± 20% 100VDC CER	28480	0160-3879
A29C61	0160-3454	4	1		CAPACITOR-FXD 220PF ± 10% 1KVDC CER	28480	0160-3454
A29C62	0160-3878	6			CAPACITOR-FXD 1000PF ± 20% 100VDC CER	28480	0160-3878
A29CR1	1901-0518	8	6		DIODE-SM SIG SCHOTTKY	28480	1901-0518
A29CR2	1901-0518	8			DIODE-SM SIG SCHOTTKY	28480	1901-0518
A29CR3	1901-0518	8			DIODE-SM SIG SCHOTTKY	28480	1901-0518
A29CR4	1901-0518	8			DIODE-SM SIG SCHOTTKY	28480	1901-0518
A29CR5	1901-0518	8			DIODE-SM SIG SCHOTTKY	28480	1901-0518
A29CR6	1901-0518	8			DIODE-SM SIG SCHOTTKY	28480	1901-0518
A29J1	1250-0544	9	5		CONNECTOR-RF MALE SMB	28480	1250-0544
A29J2	1250-0544	9			CONNECTOR-RF MALE SMB	28480	1250-0544
A29J3	1250-0544	9			CONNECTOR-RF MALE SMB	28480	1250-0544
A29J4	1250-0544	9			CONNECTOR-RF MALE SMB	28480	1250-0544
A29J5	1250-0544	9			CONNECTOR-RF MALE SMB	28480	1250-0544
A29L1	9140-0238	3	2		INDUCTOR RF-CH-MLD 82UH 5% 166DX 385LG	28480	9140-0238
A29L2	9140-0238	3			INDUCTOR RF-CH-MLD 82UH 5% 166DX 385LG	28480	9140-0238
A29L3	9140-0143	9	2		INDUCTOR RF-CH-MLD 3.3UH 10% 105DX 26LG	28480	9140-0143
A29L4	9140-0143	9			INDUCTOR RF-CH-MLD 3.3UH 10% 105DX 26LG	28480	9140-0143
A29L5	9100-2261	2	1		INDUCTOR RF-CH-MLD 2.7UH 10% 105DX 26LG	28480	9100-2261
A29L6	9140-0114	4	1		INDUCTOR RF-CH-MLD 10UH 10% 166DX 385LG	28480	9140-0114
A29L7	9100-2255	4	4		INDUCTOR RF-CH-MLD 470NH 10% 105DX 26LG	28480	9100-2255
A29L8	9100-0368	6	1		INDUCTOR RF-CH-MLD 330NH 10% 105DX 26LG	28480	9100-0368
A29L9	9100-2257	6	3		INDUCTOR RF-CH-MLD 820NH 10% 105DX 26LG	28480	9100-2257
A29L10	9100-2255	4			INDUCTOR RF-CH-MLD 470NH 10% 105DX 26LG	28480	9100-2255
A29L11	9100-2257	6			INDUCTOR RF-CH-MLD 820NH 10% 105DX 26LG	28480	9100-2257
A29L12	9100-2255	4			INDUCTOR RF-CH-MLD 470NH 10% 105DX 26LG	28480	9100-2255
A29L13	9100-2257	6			INDUCTOR RF-CH-MLD 820NH 10% 105DX 26LG	28480	9100-2257
A29L14	9100-2255	4			INDUCTOR RF-CH-MLD 470NH 10% 105DX 26LG	28480	9100-2255
A29L15	9100-2256	5	1		INDUCTOR RF-CH-MLD 560NH 10% 105DX 26LG	28480	9100-2256
A29L16	9100-2891	4	1		INDUCTOR RF-CH-MLD 50NH 10% 105DX 26LG	28480	9100-2891
A29MP1	1205-0250	9	1		THERMISTOR LINK T0-5/T0-39	28480	1205-0250
A29MP2	2190-0124	4	1		WASHER-LK INTL T NO 10 195-IN-ID	28480	2190-0124
A29MP3	2200-0101	0	3		SCREW-MACH 4-40 188-IN-LG PAN-HD-POZI	00000	ORDER BY DESCRIPTION
A29MP4	2200-0101	0			SCREW-MACH 4-40 188-IN-LG PAN-HD-POZI	00000	ORDER BY DESCRIPTION
A29MP5	2200-0101	0			SCREW-MACH 4-40 188-IN-LG PAN-HD-POZI	00000	ORDER BY DESCRIPTION
A29MP6	2950-0078	9	1		NUT-HEX-DBL-CHAM 10-32-THD 067-IN-THK	28480	2950-0078
A29MP7	08340-20090	3	1		COVER-PC REF PHASE DETECTOR	28480	08340-20090
A29MP8	86701-40001	9	2		EXTRACTOR-PC BOARD	28480	86701-40001
A29MP9	86701-40001	9			EXTRACTOR-PC BOARD	28480	86701-40001
A29Q1	1854-0019	3	3		TRANSISTOR NPN SI TO-18 PD=360MW	28480	1854-0019
A29Q2	1854-0019	3			TRANSISTOR NPN SI TO-18 PD=360MW	28480	1854-0019
A29Q3	1854-0019	3			TRANSISTOR NPN SI TO-18 PD=360MW	28480	1854-0019
A29Q4	1855-0049	1	1		TRANSISTOR-JFET DUAL N-CHAN D-MODE SI	28480	1855-0049
A29Q5	1853-0451	5	2		TRANSISTOR PNP 2N3799 SI TO-18 PD=360MW	01295	2N3799
A29Q6	1853-0451	5			TRANSISTOR PNP 2N3799 SI TO-18 PD=360MW	01295	2N3799
A29Q7	1853-0034	0	1		TRANSISTOR PNP SI TO-18 PD=360MW	28480	1853-0034
A29R1	0757-0399	5	2		RESISTOR 82 5 1% 125W F TC=0 ± 100	24546	C4-1/8-T0-82R5-F
A29R2	0757-0417	8	1		RESISTOR 562 1% 125W F TC=0 ± 100	24546	C4-1/8-T0-562R-F
A29R3	0757-0416	7	4		RESISTOR 511 1% 125W F TC=0 ± 100	24546	C4-1/8-T0-511R-F
A29R4	0757-0401	0	3		RESISTOR 100 1% 125W F TC=0 ± 100	24546	C4-1/8-T0-101-F
A29R5	0698-3156	2	1		RESISTOR 14.7K 1% 125W F TC=0 ± 100	24546	C4-1/8-T0-1472-F

A29 Reference Phase Detector Component-Level Troubleshooting

Table A29-7. A29 Reference Phase Detector Replaceable Parts

Reference Designation	HP Part Number	C	D	Qty	Description	Mfr Code	Mfr Part Number
A29R6	0757-0401	0			RESISTOR 100 1% 125W F TC=0±100	24546	C4-1/8-T0-101-F
A29R7	0757-0420	3		1	RESISTOR 750 1% 125W F TC=0±100	24546	C4-1/8-T0-751-F
A29R8	0757-0438	3		1	RESISTOR 5 11K 1% 125W F TC=0±100	24546	C4-1/8-T0-5111-F
A29R9	0757-0399	5			RESISTOR 82.5 1% 125W F TC=0±100	24546	C4-1/8-T0-82R5-F
A29R10	0698-7222	1		1	RESISTOR 261 1% 05W F TC=0±100	24546	C3-1/8-T0-261R-F
A29R11	0698-7219	6		1	RESISTOR 196 1% 05W F TC=0±100	24546	C3-1/8-T0-196R-F
A29R12	0757-0442	9		5	RESISTOR 10K 1% 125W F TC=0±100	24546	C4-1/8-T0-1002-F
A29R13	0698-3453	2		3	RESISTOR 196K 1% 125W F TC=0±100	24546	C4-1/8-T0-1963-F
A29R14	0757-0442	9			RESISTOR 10K 1% 125W F TC=0±100	24546	C4-1/8-T0-1002-F
A29R15	0698-3453	2			RESISTOR 196K 1% 125W F TC=0±100	24546	C4-1/8-T0-1963-F
A29R16	0757-0441	8		2	RESISTOR 8 25K 1% 125W F TC=0±100	24546	C4-1/8-T0-8251-F
A29R17	0698-3438	3		2	RESISTOR 147 1% 125W F TC=0±100	24546	C4-1/8-T0-147R-F
A29R18	0757-0346	2		6	RESISTOR 10 1% 125W F TC=0±100	24546	C4-1/8-T0-10R0-F
A29R19	0757-0346	2			RESISTOR 10 1% 125W F TC=0±100	24546	C4-1/8-T0-10R0-F
A29R20	0757-0441	8			RESISTOR 8 25K 1% 125W F TC=0±100	24546	C4-1/8-T0-8251-F
A29R21	0698-3438	3			RESISTOR 147 1% 125W F TC=0±100	24546	C4-1/8-T0-147R-F
A29R22	0698-3136	8		1	RESISTOR 17 8K 1% 125W F TC=0±100	24546	C4-1/8-T0-1782-F
A29R23	0757-0346	2			RESISTOR 10 1% 125W F TC=0±100	24546	C4-1/8-T0-10R0-F
A29R24	0698-3154	0		5	RESISTOR 4 22K 1% 125W F TC=0±100	24546	C4-1/8-T0-4221-F
A29R25	0757-0346	2			RESISTOR 10 1% 125W F TC=0±100	24546	C4-1/8-T0-10R0-F
A29R26	0757-0280	3		5	RESISTOR 1K 1% 125W F TC=0±100	24546	C4-1/8-T0-1001-F
A29R27	0698-3154	0			RESISTOR 4 22K 1% 125W F TC=0±100	24546	C4-1/8-T0-4221-F
A29R28	0698-3450	9		1	RESISTOR 42 2K 1% 125W F TC=0±100	24546	C4-1/8-T0-4222-F
A29R29	0698-3449	6		1	RESISTOR 28 7K 1% 125W F TC=0±100	24546	C4-1/8-T0-2872-F
A29R30	0757-0444	1		2	RESISTOR 12 1K 1% 125W F TC=0±100	24546	C4-1/8-T0-1212-F
A29R31	0698-3154	0			RESISTOR 4 22K 1% 125W F TC=0±100	24546	C4-1/8-T0-4221-F
A29R32	0757-0346	2			RESISTOR 10 1% 125W F TC=0±100	24546	C4-1/8-T0-10R0-F
A29R33	0698-3154	0			RESISTOR 4 22K 1% 125W F TC=0±100	24546	C4-1/8-T0-4221-F
A29R34	0757-0346	2			RESISTOR 10 1% 125W F TC=0±100	24546	C4-1/8-T0-10R0-F
A29R35	0757-0280	3			RESISTOR 1K 1% 125W F TC=0±100	24546	C4-1/8-T0-1001-F
A29R36	0757-0444	1			RESISTOR 12 1K 1% 125W F TC=0±100	24546	C4-1/8-T0-1212-F
A29R37	0757-0200	7		1	RESISTOR 5 62K 1% 125W F TC=0±100	24546	C4-1/8-T0-5621-F
A29R38	0757-0421	4		2	RESISTOR 825 1% 125W F TC=0±100	24546	C4-1/8-T0-825R-F
A29R39	0757-0440	7		1	RESISTOR 7 5K 1% 125W F TC=0±100	24546	C4-1/8-T0-7501-F
A29R40	0757-0394	0		2	RESISTOR 51 1 1% 125W F TC=0±100	24546	C4-1/8-T0-51R1-F
A29R41	0698-3446	3		2	RESISTOR 383 1% 125W F TC=0±100	24546	C4-1/8-T0-383R-F
A29R42	0698-0085	0		3	RESISTOR 2 61K 1% 125W F TC=0±100	24546	C4-1/8-T0-2611-F
A29R43	0757-0442	9			RESISTOR 10K 1% 125W F TC=0±100	24546	C4-1/8-T0-1002-F
A29R44	0757-0442	9			RESISTOR 10K 1% 125W F TC=0±100	24546	C4-1/8-T0-1002-F
A29R45	0757-0280	3			RESISTOR 1K 1% 125W F TC=0±100	24546	C4-1/8-T0-1001-F
A29R46	0698-3154	0			RESISTOR 4 22K 1% 125W F TC=0±100	24546	C4-1/8-T0-4221-F
A29R47	0698-3453	2			RESISTOR 196K 1% 125W F TC=0±100	24546	C4-1/8-T0-1963-F
A29R48	0757-0442	9			RESISTOR 10K 1% 125W F TC=0±100	24546	C4-1/8-T0-1002-F
A29R49	0698-7285	6		1	RESISTOR 110K 1% 05W F TC=0±100	24546	C3-1/8-T0-1103-F
A29R50	0698-3157	3		2	RESISTOR 19 6K 1% 125W F TC=0±100	24546	C4-1/8-T0-1962-F
A29R51	0698-3157	3			RESISTOR 19 6K 1% 125W F TC=0±100	24546	C4-1/8-T0-1962-F
A29R52	0757-0401	0			RESISTOR 100 1% 125W F TC=0±100	24546	C4-1/8-T0-101-F
A29R53	0698-3440	7		2	RESISTOR 196 1% 125W F TC=0±100	24546	C4-1/8-T0-196R-F
A29R54	0698-7234	5		1	RESISTOR 825 1% 05W F TC=0±100	24546	C3-1/8-T0-825R-F
A29R55	0698-7257	2		1	RESISTOR 7 5K 1% 05W F TC=0±100	24546	C3-1/8-T0-7501-F
A29R56	0757-0394	0			RESISTOR 51 1 1% 125W F TC=0±100	24546	C4-1/8-T0-51R1-F
A29R57	0698-3446	3			RESISTOR 383 1% 125W F TC=0±100	24546	C4-1/8-T0-383R-F
A29R58	0698-7246	9		1	RESISTOR 2 61K 1% 05W F TC=0±100	24546	C3-1/8-T0-2611-F
A29R59	0698-3440	7			RESISTOR 196 1% 125W F TC=0±100	24546	C4-1/8-T0-196R-F
A29R60					NOT ASSIGNED		
A29R61	0757-0280	3			RESISTOR 1K 1% 125W F TC=0±100	24546	C4-1/8-T0-1001-F
A29R62	0757-0278	9		1	RESISTOR 1 78K 1% 125W F TC=0±100	24546	C4-1/8-T0-1781-F
A29R63	0698-0085	0			RESISTOR 2 61K 1% 125W F TC=0±100	24546	C4-1/8-T0-2611-F
A29R64	0698-3132	4		2	RESISTOR 261 1% 125W F TC=0±100	24546	C4-1/8-T0-2610-F
A29R65	0698-0085	0			RESISTOR 2 61K 1% 125W F TC=0±100	24546	C4-1/8-T0-2611-F

A29 Reference Phase Detector Component-Level Troubleshooting

Table A29-7. A29 Reference Phase Detector Replaceable Parts

Reference Designation	HP Part Number	C D	Qty	Description	Mfr Code	Mfr Part Number
A29R66	0757-0421	4		RESISTOR 825 1% 125W F TC=0±100	24546	C4-1/8-T0-825R-F
A29R67	0757-0280	3		RESISTOR 1K 1% 125W F TC=0±100	24546	C4-1/8-T0-1001-F
A29R68	0757-0416	7		RESISTOR 511 1% 125W F TC=0±100	24546	C4-1/8-T0-511R-F
A29R69	0757-0416	7		RESISTOR 511 1% 125W F TC=0±100	24546	C4-1/8-T0-511R-F
A29R70	0757-0416	7		RESISTOR 511 1% 125W F TC=0±100	24546	C4-1/8-T0-511R-F
A29R71	0757-0274	5	1	RESISTOR 1.21K 1% 125W F TC=0±100	24546	C4-1/8-T0-1211-F
A29R72	0698-3132	4		RESISTOR 261 1% 125W F TC=0±100	24546	C4-1/8-T0-2610-F
A29R73	0757-0317	7	1	RESISTOR 1.33K 1% 125W F TC=0±100	24546	C4-1/8-T0-1331-F
A29R74	0757-0289	2	1	RESISTOR 13.3K 1% 125W F TC=0±100	19701	MF4C1/8-T0-1332-F
A29R75	0698-7236	7	1	RESISTOR 1K 1% 05W F TC=0±100	24546	C3-1/8-T0-1001-F
A29T1	08552-6044	1	2	TRANSFORMER-RF 5 PIN	28480	08552-6044
A29T2	08552-6044	1		TRANSFORMER-RF 5 PIN	28480	08552-6044
A29TP1	0360-0535	0	1	TERMINAL TEST POINT PCB	00000	ORDER BY DESCRIPTION
A29U1	1858-0032	8	1	TRANSISTOR ARRAY 14-PIN PLSTC DIP	3L585	CA3146E
A29U2	1820-0328	6	1	IC GATE TTL NOR QUAD 2-INP	01295	SN7402N
A29U3	1820-1383	5	1	IC CNTR ECL BCD POS-EDGE-TRIG	04713	MC10138L
A29U4	1820-0802	1	1	IC GATE ECL NOR QUAD 2-INP	04713	MC10102P
A29U5	1820-0223	0	1	IC OP AMP GP TO-99 PKG	3L585	CA301AT
A29U6	1820-0429	8	1	IC V RGLTR TO-39	18324	LM309H
A29VR1	1902-3082	9	1	DIODE-ZNR 4.64V 5% DO-35 PD= 4W	28480	1902-3082
A29VR2	1902-3256	9	1	DIODE-ZNR 23.7V 5% DO-35 PD= 4W	28480	1902-3256
A29W1	08340-60101	1	1	CABLE ASSEMBLY-A29	28480	08340-60101

A30 100 MHz Voltage-Controlled Crystal Oscillator (VCXO) Circuit Description

ASSEMBLY PURPOSE

The A30 100 MHz VCXO contains a voltage controlled crystal oscillator, a 100 MHz buffer amplifier, a x4 frequency multiplier (quadrupler), and a 400 MHz amplifier. With the A29 reference phase detector, the A30 assembly forms the reference phase-locked loop. The 100 MHz and 400 MHz outputs are used as frequency references by other assemblies in the instrument.

100 MHZ OSCILLATOR (BLOCK A)

The transistor and associated circuitry function as a 100 MHz voltage controlled crystal oscillator (VCXO). The output signal to the 100 MHz buffer amplifier (block B) is limited to an amplitude swing of $\pm 0.4V$. This output signal is also divided down to a level of $\pm 0.25V$ before completing the feedback loop.

A 100 MHz quartz crystal and a varactor diode are the principle frequency determining elements in the feedback loop. The varactor diode provides the electrical tuning for the oscillator. Changing the (reverse) bias voltage on the varactor changes the oscillator frequency (± 1 kHz). The tuning input for the varactor comes from the output of the A29 reference phase detector.

The tune voltage (TUNE) can be monitored at TP1, on the top cover of the casting that houses the A30 assembly. The variable capacitor is adjusted with the loop locked so that TUNE is approximately $-8.0V$, to center the tuning range. A factory-selected inductor adjusts the symmetry of the oscillator output signal over the VCXO tuning range. The signal level is maximum at 100 MHz and is, over its tuning range, symmetrical about 100 MHz. Test point 3 is approximately $-14.8V$.

100 MHZ BUFFER AMPLIFIER (BLOCK B)

Three buffer amplifiers isolate the VCXO from load variations that would otherwise pull the oscillator frequency. The collector output of Q8, 100 MHz OUT, is sent to the A8A1 3.7 GHz oscillator. Q8's emitter output is input to the emitter of Q11. The output of U11 goes to power splitter T3. The two outputs of T3 are used as follows:

1. One of T3's output signals is amplified and applied to a second power splitter, T2, which in turn produces:
 - a. 100 MHz OUT signal sent to the A29 reference phase detector via J1.
 - b. 100 MHz OUT signal that is sent through J2 to the A39 phase lock loop 3 (PLL3) upconverter.
2. The other output from power splitter T3 is buffered and input to the quadrupler (block C).

QUADRUPLER (BLOCK C)

The 100 MHz signal from block B is applied to a power splitter (T1). The two power splitter outputs are amplified and rectified to produce a full-wave rectified signal that is rich in even harmonics. A tuned tank circuit passes the 4th harmonic, 400 MHz, to the 400 MHz amplifier (block D).

400 MHZ AMPLIFIER (BLOCK D)

The 400 MHz input from block C is amplified by approximately 40 dB, filtered to remove undesired harmonics, and then attenuated to $-10\text{ dBm} \pm 1\text{ dB}$. This signal is sent to the A31 M/N phase detector.

POWER SUPPLIES (BLOCK E)

The +20 and -10V supplies are filtered in this block. The voltage at TP2 is approximately 18.2V. The voltage at TP4 is approximately -8.6V.

A30 100 MHz Voltage-Controlled Crystal Oscillator Component-Level Troubleshooting

100 MHZ OSCILLATOR (BLOCK A)

Reference UnlockThe output of the 100 MHz VCXO should be phase-locked at 100 MHz. When troubleshooting the VCXO for a REFERENCE UNLOCK:

1. Remove the A30 assembly from the instrument. Cover finger connector P1-14 with plastic tape. Install the assembly into the instrument on an extender board.
2. Apply $-8.0V$ to the TUNE test point, TP1 (on the top cover of the casting that houses the board). This should tune the oscillator to $100\text{ MHz} \pm 100\text{ Hz}$. Measure the output of block A (cathode of CR4) with a spectrum analyzer and an active probe. An active probe is necessary because other measuring devices would affect the circuit's frequency. If a spectrum analyzer/active probe are not available, measure the emitter of Q9 (block B). If the signal is missing, troubleshoot Q5 (and Q9 if necessary), and surrounding circuitry. If the signal is present, proceed to **Oscillator Adjustment**.

Typical Q5 bias voltage levels:

emitter	$-12.8V$
base	$-11.9V$
collector	$0.0V$

TP3 should be approximately $-14.8V$.

NOTE: Remove the tape from A30 P1-14! Remove the extender board and replace A30.

100 MHZ BUFFER AMPLIFIERS (BLOCK B)

The 100 MHz OUT signals at A30J1, J2, and J3 should be $0\text{ dBm} \pm 1\text{ dB}$. If no signal is present at J3, troubleshoot Q9, Q8, and the 100 MHz oscillator.

If the output of J3 is correct but the signal at J2 and/or J1 is low or missing, troubleshoot the signal path that includes Q11 and Q6.

The approximate bias voltages for the 100 MHz buffer amplifier transistors are shown in Table A30-1.

Table A30-1. 100 MHz Buffer Amplifiers - Approximate Bias Voltage Levels

Transistor	Q6	Q7	Q8	Q9	Q11
Emitter	3.8	3.8	4.3	5.0	3.8
Base	4.5	4.5	5.0	5.5	4.5
Collector	9.2	9.1	10.0	11.0	9.3

QUADRUPLER (BLOCK C) 400 MHz AMPLIFIER (BLOCK D)

If the 400 MHz OUT signal level is not between -9 and -11 dBm, check the harmonic levels (see below).

The 200 and 800 MHz harmonics of 100 MHz at A30W1, relative to the 400 MHz signal level, should be at least 25 dB down. The 100, 300, 500, 600, 700, and 900 MHz harmonics should be at least 40 dB down. If the harmonic levels are too high, adjust C1 and C2 for the maximum 400 MHz signal level with the lowest possible harmonic levels; then recheck the 400 MHz OUT signal level.

If harmonics are within specification, and the 100 MHz OUT signals are correct, but the signal level is still low, or the 400 MHz signal is missing, troubleshoot the signal path that includes the 100 MHz buffer amplifier Q7 (block B), the quadrupler transistors Q3 and Q4, and the 400 MHz amplifier Q2 and Q1.

Table A30-2 lists the typical bias voltage levels for Q1 through Q4.

Table A30-2. Approximate Bias Levels for Quadrupler and 400 MHz Amplifier

Transistor	Q1	Q2	Q3	Q4
Emitter	-6.6	-6.6	-4.6	-5.1
Base	-5.9	-5.9	-5.9	-5.9
Collector	0.0	0.0	0.0	0.0

Table A30-3. A30 100 MHz VCXO Pin I/O

Pin	Mnemonic	Levels	Source	Destination
1 2	-10V	-10V	XA34P2-8,9	*E
3 4	-40V	+40V	XA34P2-6,7	*A
5 6	+20V GND	+20V 0V	XA34P2-2, 3 INSTRUMENT GROUND	*E *E
7 8	GND GND	0V 0V	INSTRUMENT GROUND INSTRUMENT GROUND	*E *E
9 10	GND GND	0V 0V	INSTRUMENT GROUND INSTRUMENT GROUND	*E *E
11 12	GND TUNE GROUND	0V 0V	INSTRUMENT GROUND XA29P1-12	*E A
13 14	TUNE VOLTAGE		XA29P1-13	A
15	GND	0V	INSTRUMENT GROUND	*E

A single letter in the source or destination column refers to a function block on this assembly schematic.

An asterisk (*) denotes multiple sources or destinations; refer to the A34 Reference Loop - M/N Motherboard Schematic Diagram for a complete representation of signal sources and destinations.

A30 100 MHz Voltage-Controlled Crystal Oscillator (VCXO) Component-Level Troubleshooting

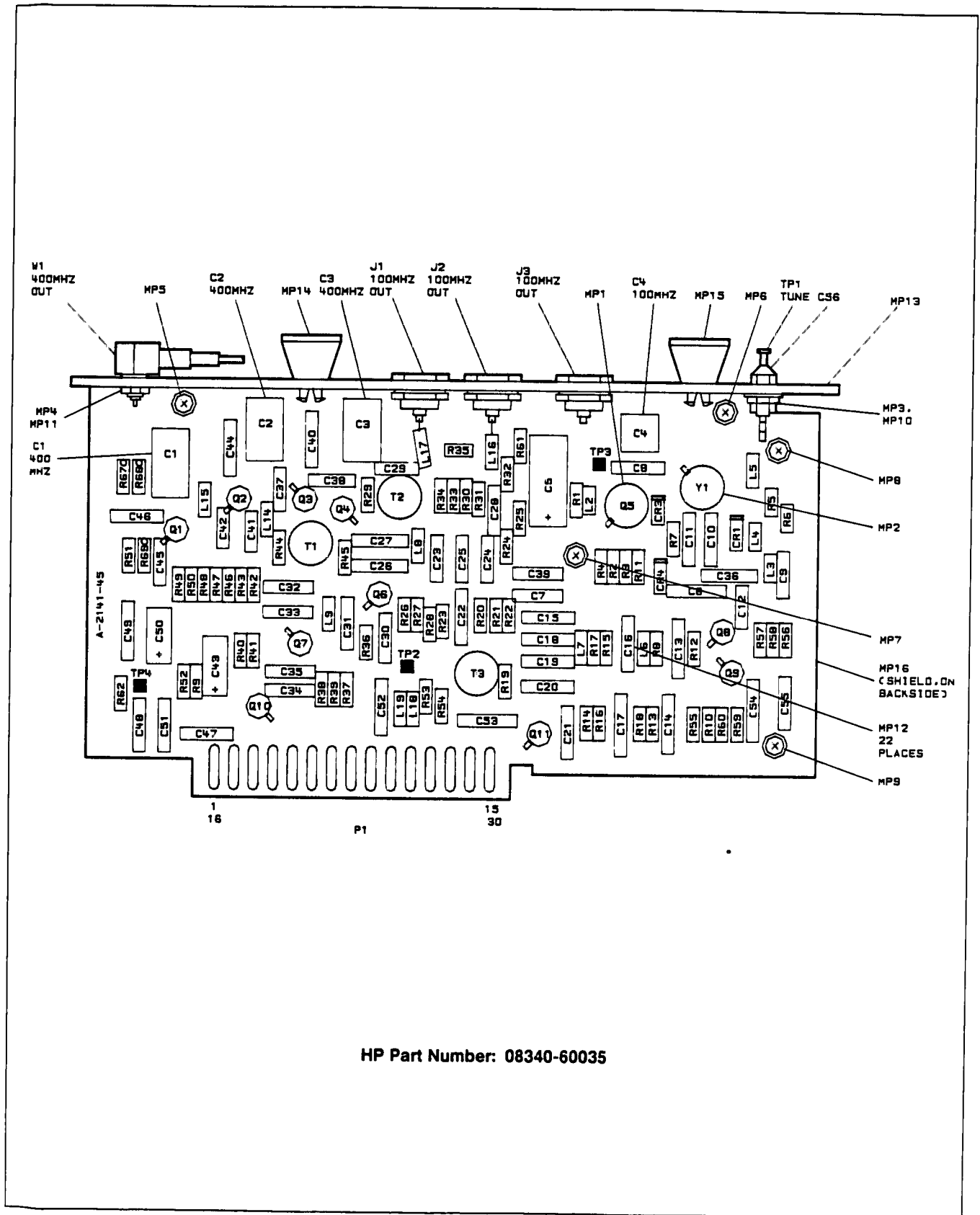

Figure A30-1. A30 100 MHz VCXO, Component Location Diagram

830-10003 VOLTAGE-CONTROLLED CRYSTAL OSCILLATOR (VCO)
 28340-80035

● 173 ● 172 ● 174 ● 171

NOTES

1. ALL TEST POINTS SHOWN ARE IN MULTIPLE LOCATIONS THROUGHOUT THE BOARD UNLESS OTHERWISE SPECIFIED.
2. LOC. L11 AND L12 ARE PLATED ON THE BOARD AND 42MH CENTER.
3. CONDUCTORS ARE ELECTRICALLY CONNECTED TO THE BOARD BY THE PLATING OVER THE BOARD MATERIAL.

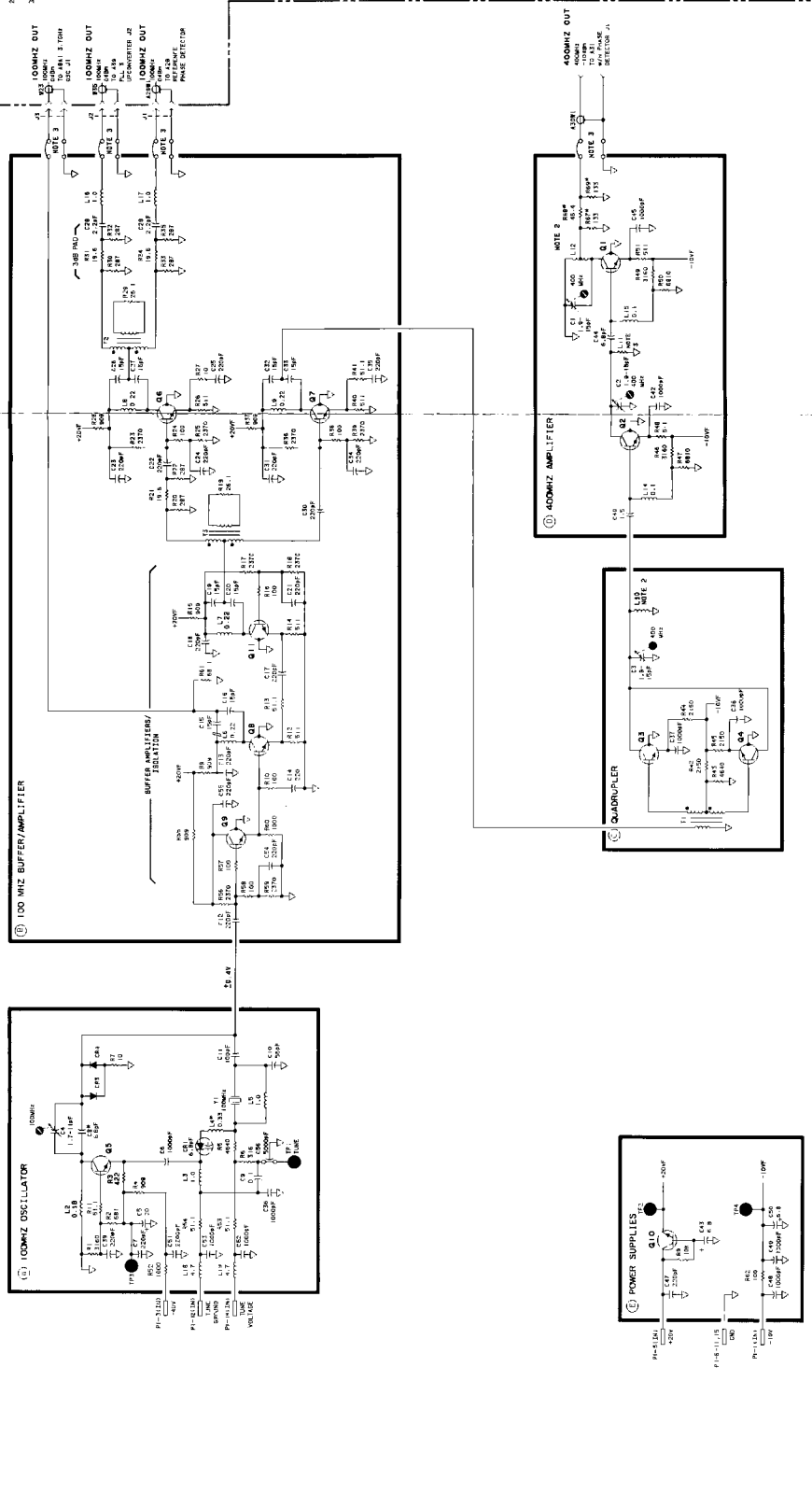

Figure A30-2. A30 100 MHz VCO, Schematic Diagram
 Reference Loop - M/N Loop A30-7/A30-8

A30 100 MHz Voltage-Controlled Crystal Oscillator (VCXO) Component-Level Troubleshooting

Table A30-4. A30 100 MHz VCXO Replaceable Parts

Reference Designation	HP Part Number	C D	Qty	Description	Mfr Code	Mfr Part Number
A30	08340-60035	0	1	100 MHZ VCXO	28480	08340-60035
A30C1	0121-0495	5	3	CAPACITOR-V TRMR-AIR 1 9-15.7PF 175V	74970	187-0309-125
A30C2	0121-0495	5		CAPACITOR-V TRMR-AIR 1 9-15 7PF 175V	74970	187-0309-125
A30C3	0121-0495	5		CAPACITOR-V TRMR-AIR 1 9-15 7PF 175V	74970	187-0309-125
A30C4	0121-0493	3	1	CAPACITOR-V TRMR-AIR 1 7-11PF 175V	74970	187-0306-125
A30C5	0180-0049	9	1	CAPACITOR-FXD 20UF +75-10% 50VDC AL	56289	30D206G050CC2
A30C6	0160-3456	6	5	CAPACITOR-FXD 1000PF ± 10% 1KVDC CER	28480	0160-3456
A30C7	0160-3454	4	19	CAPACITOR-FXD 220PF ± 10% 1KVDC CER	28480	0160-3454
A30C8*	0160-2253	9	1	CAPACITOR-FXD 6 8PF ± 5PF 100VDC CER	28480	0160-2253
A30C9	0160-4084	8	1	CAPACITOR-FXD 1UF ± 20% 50VDC CER	28480	0160-4084
A30C10	0140-0191	8	1	CAPACITOR-FXD 56PF ± 5% 300VDC MICA	72136	DM15E560J0300WV1CR
A30C11	0160-2204	0	1	CAPACITOR-FXD 100PF ± 5% 300VDC MICA	28480	0160-2204
A30C12	0160-3454	4		CAPACITOR-FXD 220PF ± 10% 1KVDC CER	28480	0160-3454
A30C13	0160-3454	4		CAPACITOR-FXD 220PF ± 10% 1KVDC CER	28480	0160-3454
A30C14	0160-3454	4		CAPACITOR-FXD 220PF ± 10% 1KVDC CER	28480	0160-3454
A30C15	0160-2261	9	8	CAPACITOR-FXD 15PF ± 5% 500VDC CER 0 ± 30	28480	0160-2261
A30C16	0160-2261	9		CAPACITOR-FXD 15PF ± 5% 500VDC CER 0 ± 30	28480	0160-2261
A30C17	0160-3454	4		CAPACITOR-FXD 220PF ± 10% 1KVDC CER	28480	0160-3454
A30C18	0160-3454	4		CAPACITOR-FXD 220PF ± 10% 1KVDC CER	28480	0160-3454
A30C19	0160-2261	9		CAPACITOR-FXD 15PF ± 5% 500VDC CER 0 ± 30	28480	0160-2261
A30C20	0160-2261	9		CAPACITOR-FXD 15PF ± 5% 500VDC CER 0 ± 30	28480	0160-2261
A30C21	0160-3454	4		CAPACITOR-FXD 220PF ± 10% 1KVDC CER	28480	0160-3454
A30C22	0160-3454	4		CAPACITOR-FXD 220PF ± 10% 1KVDC CER	28480	0160-3454
A30C23	0160-3454	4		CAPACITOR-FXD 220PF ± 10% 1KVDC CER	28480	0160-3454
A30C24	0160-3454	4		CAPACITOR-FXD 220PF ± 10% 1KVDC CER	28480	0160-3454
A30C25	0160-3454	4		CAPACITOR-FXD 220PF ± 10% 1KVDC CER	28480	0160-3454
A30C26	0160-2261	9		CAPACITOR-FXD 15PF ± 5% 500VDC CER 0 ± 30	28480	0160-2261
A30C27	0160-2261	9		CAPACITOR-FXD 15PF ± 5% 500VDC CER 0 ± 30	28480	0160-2261
A30C28	0160-3872	0	2	CAPACITOR-FXD 2 2PF ± 25PF 200VDC CER	28480	0160-3872
A30C29	0160-3872	0		CAPACITOR-FXD 2 2PF ± 25PF 200VDC CER	28480	0160-3872
A30C30	0160-3454	4		CAPACITOR-FXD 220PF ± 10% 1KVDC CER	28480	0160-3454
A30C31	0160-3454	4		CAPACITOR-FXD 220PF ± 10% 1KVDC CER	28480	0160-3454
A30C32	0160-2261	9		CAPACITOR-FXD 15PF ± 5% 500VDC CER 0 ± 30	28480	0160-2261
A30C33	0160-2261	9		CAPACITOR-FXD 15PF ± 5% 500VDC CER 0 ± 30	28480	0160-2261
A30C34	0160-3454	4		CAPACITOR-FXD 220PF ± 10% 1KVDC CER	28480	0160-3454
A30C35	0160-3454	4		CAPACITOR-FXD 220PF ± 10% 1KVDC CER	28480	0160-3454
A30C36	0160-3878	6	7	CAPACITOR-FXD 1000PF ± 20% 100VDC CER	28480	0160-3878
A30C37	0160-3878	6		CAPACITOR-FXD 1000PF ± 20% 100VDC CER	28480	0160-3878
A30C38	0160-3878	6		CAPACITOR-FXD 1000PF ± 20% 100VDC CER	28480	0160-3878
A30C39	0160-3454	4		CAPACITOR-FXD 220PF ± 10% 1KVDC CER	28480	0160-3454
A30C40	0160-2238	0	1	CAPACITOR-FXD 1 5PF ± 25PF 500VDC CER	28480	0160-2238
A30C41	0160-3878	6		CAPACITOR-FXD 1000PF ± 20% 100VDC CER	28480	0160-3878
A30C42	0160-3878	6		CAPACITOR-FXD 1000PF ± 20% 100VDC CER	28480	0160-3878
A30C43	0180-0116	1	2	CAPACITOR-FXD 6 8UF ± 10% 35VDC TA	56289	150D685X9035B2
A30C44	0160-2253	9	1	CAPACITOR-FXD 6 8PF ± 25PF 500VDC CER	28480	0160-2253
A30C45	0160-3878	6		CAPACITOR-FXD 1000PF ± 20% 100VDC CER	28480	0160-3878
A30C46	0160-3878	6		CAPACITOR-FXD 1000PF ± 20% 100VDC CER	28480	0160-3878
A30C47	0160-3454	4		CAPACITOR-FXD 220PF ± 10% 1KVDC CER	28480	0160-3454
A30C48	0160-3456	6		CAPACITOR-FXD 1000PF ± 10% 1KVDC CER	28480	0160-3456
A30C49	0160-3456	6		CAPACITOR-FXD 1000PF ± 10% 1KVDC CER	28480	0160-3456
A30C50	0180-0116	1		CAPACITOR-FXD 6 8UF ± 10% 35VDC TA	56289	150D685X9035B2
A30C51	0160-4299	7	1	CAPACITOR-FXD 2200PF ± 20% 250VDC CER	56289	C087F251F222MS22-CDH
A30C52	0160-3456	6		CAPACITOR-FXD 1000PF ± 10% 1KVDC CER	28480	0160-3456
A30C53	0160-3456	6		CAPACITOR-FXD 1000PF ± 10% 1KVDC CER	28480	0160-3456
A30C54	0160-3454	4		CAPACITOR-FXD 220PF ± 10% 1KVDC CER	28480	0160-3454
A30C55	0160-3454	4		CAPACITOR-FXD 220PF ± 10% 1KVDC CER	28480	0160-3454

A30 100 MHz Voltage-Controlled Crystal Oscillator (VCXO) Component-Level Troubleshooting

Table A30-4. A30 100 MHz VCXO Replaceable Parts

Reference Designation	HP Part Number	C	D	Qty	Description	Mfr Code	Mfr Part Number
A30C56	0160-2437	1	1	1	CAPACITOR-FDTHRU 5000PF +80 -20% 200v	28480	0160-2437
A30CR1	0122-0245	5	1	1	DIODE-VVC 1N5139 6.8PF 10% NOT ASSIGNED	01281	1N5139
A30CR2							
A30CR3	1901-0539	3	2	2	DIODE-SM SIG SCHOTTKY	28480	1901-0539
A30CR4	1901-0539	3			DIODE-SM SIG SCHOTTKY	28480	1901-0539
A30E1	9170-0029	3	1	1	CORE-SHIELDING BEAD	28480	9170-0029
A30J1	1250-0544	9	3	3	CONNECTOR-RF MALE SMB	28480	1250-0544
A30J2	1250-0544	9			CONNECTOR-RF MALE SMB	28480	1250-0544
A30J3	1250-0544	9			CONNECTOR-RF MALE SMB	28480	1250-0544
A30L1					NOT ASSIGNED		
A30L2	9100-2250	9	1	1	INDUCTOR RF-CH-MLD 180NH 10% 105DX 26LG	28480	9100-2250
A30L3	9140-0158	6	3	3	INDUCTOR RF-CH-MLD 1UH 10% 105DX 26LG	28480	9140-0158
A30L4*	9100-0368	6	1	1	INDUCTOR RF-CH-MLD 330NH 10% 105DX 26LG	28480	9100-0368
A30L5	9100-2538	6	1	1	INDUCTOR RF-CH-MLD 1UH 10% 161DX 385LG	28480	9100-2538
A30L6	9100-2251	0	4	4	INDUCTOR RF-CH-MLD 220NH 10% 105DX 26LG	28480	9100-2251
A30L7	9100-2251	0			INDUCTOR RF-CH-MLD 220NH 10% 105DX 26LG	28480	9100-2251
A30L8	9100-2251	0			INDUCTOR RF-CH-MLD 220NH 10% 105DX 26LG	28480	9100-2251
A30L9	9100-2251	0			INDUCTOR RF-CH-MLD 220NH 10% 105DX 26LG	28480	9100-2251
A30L10-13					NOT ASSIGNED		
A30L14	9100-2247	4	2	2	INDUCTOR RF-CH-MLD 100NH 10% 105DX 26LG	28480	9100-2247
A30L15	9100-2247	4			INDUCTOR RF-CH-MLD 100NH 10% 105DX 26LG	28480	9100-2247
A30L16	9140-0158	6			INDUCTOR RF-CH-MLD 1UH 10% 105DX 26LG	28480	9140-0158
A30L17	9140-0158	6			INDUCTOR RF-CH-MLD 1UH 10% 105DX 26LG	28480	9140-0158
A30L18	9140-0144	0	2	2	INDUCTOR RF-CH-MLD 4.7UH 10% 105DX 26LG	28480	9140-0144
A30L19	9140-0144	0			INDUCTOR RF-CH-MLD 4.7UH 10% 105DX 26LG	28480	9140-0144
A30MP1					NOT ASSIGNED		
A30MP2					NOT ASSIGNED		
A30MP3	2190-0009	4	1	1	WASHER-LK INTL T NO 8 188-IN-ID	28480	2190-0009
A30MP4	2190-0124	4	1	1	WASHER-LK INTL T NO 10 195-IN-ID	28480	2190-0124
A30MP5	2200-0101	0	2	2	SCREW-MACH 4-40 188-IN-LG PAN-HD-POZI	00000	ORDER BY DESCRIPTION
A30MP6	2200-0101	0			SCREW-MACH 4-40 188-IN-LG PAN-HD-POZI	00000	ORDER BY DESCRIPTION
A30MP7	2200-0103	2	3	3	SCREW-MACH 4-40 25-IN-LG PAN-HD-POZI	00000	ORDER BY DESCRIPTION
A30MP8	2200-0103	2			SCREW-MACH 4-40 25-IN-LG PAN-HD-POZI	00000	ORDER BY DESCRIPTION
A30MP9	2200-0103	2			SCREW-MACH 4-40 25-IN-LG PAN-HD-POZI	00000	ORDER BY DESCRIPTION
A30MP10	2580-0002	4	1	1	NUT-HEX-DBL-CHAM 8-32-THD 085-IN-THK	00000	ORDER BY DESCRIPTION
A30MP11	2950-0078	9	1	1	NUT-HEX-DBL-CHAM 10-32-THD 067-IN-THK	28480	2950-0078
A30MP12	4330-0145	9	1	1	INS. BEAD GL 062L	28480	4330-0145
A30MP13	08340-20091	4	1	1	COVER-PC VCXO	28480	08340-20091
A30MP14	86701-40001	9	2	2	EXTRACTOR-PC BOARD	28480	86701-40001
A30MP15	86701-40001	9			EXTRACTOR-PC BOARD	28480	86701-40001
A30MP16	86701-00045	7	1	1	SHIELD	28480	86701-00045
A30MP17	0460-0683	1	1	1	TAPE-FILM 1 5	28480	0460-0683
A30MP18	0460-1303	4	1	1	TAPE-SILICON SPONGE	28480	0460-1303
A30MP19	6960-0059	1	1	1	PLUG-HOLE RND-HD FOR 187-D-HOLE NYL	28480	6960-0059
A30Q1	1854-0345	8	9	9	TRANSISTOR NPN 2N5179 SI TO-72 PD=200MW	04713	2N5179
A30Q2	1854-0345	8			TRANSISTOR NPN 2N5179 SI TO-72 PD=200MW	04713	2N5179
A30Q3	1854-0345	8			TRANSISTOR NPN 2N5179 SI TO-72 PD=200MW	04713	2N5179
A30Q4	1854-0345	8			TRANSISTOR NPN 2N5179 SI TO-72 PD=200MW	04713	2N5179
A30Q5	1854-0247	9	1	1	TRANSISTOR NPN SI TO-39 PD=1W FT=800MHZ	28480	1854-0247
A30Q6	1854-0345	8			TRANSISTOR NPN 2N5179 SI TO-72 PD=200MW	04713	2N5179
A30Q7	1854-0345	8			TRANSISTOR NPN 2N5179 SI TO-72 PD=200MW	04713	2N5179
A30Q8	1854-0345	8			TRANSISTOR NPN 2N5179 SI TO-72 PD=200MW	04713	2N5179
A30Q9	1854-0345	8			TRANSISTOR NPN 2N5179 SI TO-72 PD=200MW	04713	2N5179
A30Q10	1854-0404	0	1	1	TRANSISTOR NPN SI TO-18 PD=360MW	28480	1854-0404
A30Q11	1854-0345	8			TRANSISTOR NPN 2N5179 SI TO-72 PD=200MW	04713	2N5179
A30R1	0757-0279	0	3	3	RESISTOR 3 16K 1% 125W F TC=0±100	24546	C4-1/8-T0-3161-F
A30R2	0757-0419	0	1	1	RESISTOR 681 1% 125W F TC=0±100	24546	C4-1/8-T0-681R-F
A30R3	0698-3447	4	1	1	RESISTOR 422 1% 125W F TC=0±100	24546	C4-1/8-T0-422R-F
A30R4	0757-0422	5	6	6	RESISTOR 909 1% 125W F TC=0±100	24546	C4-1/8-T0-909R-F
A30R5	0698-3155	1	2	2	RESISTOR 4 64K 1% 125W F TC=0±100	24546	C4-1/8-T0-4641-F

A30 100 MHz Voltage-Controlled Crystal Oscillator (VCXO) Component-Level Troubleshooting

Table A30-4. A30 100 MHz VCXO Replaceable Parts

Reference Designation	HP Part Number	C D	Qty	Description	Mfr Code	Mfr Part Number
A30R6	0698-7224	3	1	RESISTOR 316 1% 05W F TC=0±100	24546	C3-1/8-T0-316R-F
A30R7	0757-0346	2	2	RESISTOR 10 1% 125W F TC=0±100	24546	C4-1/8-T0-10R0-F
A30R8	0757-0422	5		RESISTOR 909 1% 125W F TC=0±100	24546	C4-1/8-T0-909R-F
A30R9	0757-0442	9	1	RESISTOR 10K 1% 125W F TC=0±100	24546	C4-1/8-T0-1002-F
A30R10	0757-0401	0	7	RESISTOR 100 1% 125W F TC=0±100	24546	C4-1/8-T0-101-F
A30R11	0757-0394	0	5	RESISTOR 51 1 1% 125W F TC=0±100	24546	C4-1/8-T0-51R1-F
A30R12	0757-0416	7	6	RESISTOR 51 1 1% 125W F TC=0±100	24546	C4-1/8-T0-511R-F
A30R13	0757-0394	0		RESISTOR 51 1 1% 125W F TC=0±100	24546	C4-1/8-T0-51R1-F
A30R14	0757-0416	7		RESISTOR 51 1 1% 125W F TC=0±100	24546	C4-1/8-T0-511R-F
A30R15	0757-0422	5		RESISTOR 909 1% 125W F TC=0±100	24546	C4-1/8-T0-909R-F
A30R16	0757-0401	0		RESISTOR 100 1% 125W F TC=0±100	24546	C4-1/8-T0-101-F
A30R17	0698-3150	6	8	RESISTOR 2 37K 1% 125W F TC=0±100	24546	C4-1/8-T0-2371-F
A30R18	0698-3150	6		RESISTOR 2 37K 1% 125W F TC=0±100	24546	C4-1/8-T0-2371-F
A30R19	0698-7198	0	2	RESISTOR 26 1 1% 05W F TC=0±100	24546	C3-1/8-T0-26R1-F
A30R20	0698-3443	0	5	RESISTOR 287 1% 125W F TC=0±100	24546	C4-1/8-T0-287R-F
A30R21	0698-3429	2	3	RESISTOR 19 6 1% 125W F TC=0±100	03888	PME55-1/8-T0-19R6-F
A30R22	0698-3443	0		RESISTOR 287 1% 125W F TC=0±100	24546	C4-1/8-T0-287R-F
A30R23	0698-3150	6		RESISTOR 2 37K 1% 125W F TC=0±100	24546	C4-1/8-T0-2371-F
A30R24	0757-0401	0		RESISTOR 100 1% 125W F TC=0±100	24546	C4-1/8-T0-101-F
A30R25	0698-3150	6		RESISTOR 2 37K 1% 125W F TC=0±100	24546	C4-1/8-T0-2371-F
A30R26	0757-0416	7		RESISTOR 51 1 1% 125W F TC=0±100	24546	C4-1/8-T0-511R-F
A30R27	0757-0346	2		RESISTOR 10 1% 125W F TC=0±100	24546	C4-1/8-T0-10R0-F
A30R28	0757-0422	5		RESISTOR 909 1% 125W F TC=0±100	24546	C4-1/8-T0-909R-F
A30R29	0698-7198	0		RESISTOR 26 1 1% 05W F TC=0±100	24546	C3-1/8-T0-26R1-F
A30R30	0698-3443	0		RESISTOR 287 1% 125W F TC=0±100	24546	C4-1/8-T0-287R-F
A30R31	0698-3429	2		RESISTOR 19 6 1% 125W F TC=0±100	03888	PME55-1/8-T0-19R6-F
A30R32	0698-3443	0		RESISTOR 287 1% 125W F TC=0±100	24546	C4-1/8-T0-287R-F
A30R33	0698-3443	0		RESISTOR 287 1% 125W F TC=0±100	24546	C4-1/8-T0-287R-F
A30R34	0698-3429	2		RESISTOR 19 6 1% 125W F TC=0±100	03888	PME55-1/8-T0-19R6-F
A30R35	0698-7223	2	1	RESISTOR 287 1% 05W F TC=0±100	24546	C3-1/8-T0-287R-F
A30R36	0698-3150	6		RESISTOR 2 37K 1% 125W F TC=0±100	24546	C4-1/8-T0-2371-F
A30R37	0757-0422	5		RESISTOR 909 1% 125W F TC=0±100	24546	C4-1/8-T0-909R-F
A30R38	0757-0401	0		RESISTOR 100 1% 125W F TC=0±100	24546	C4-1/8-T0-101-F
A30R39	0698-3150	6		RESISTOR 2 37K 1% 125W F TC=0±100	24546	C4-1/8-T0-2371-F
A30R40	0757-0416	7		RESISTOR 51 1 1% 125W F TC=0±100	24546	C4-1/8-T0-511R-F
A30R41	0757-0394	0		RESISTOR 51 1 1% 125W F TC=0±100	24546	C4-1/8-T0-51R1-F
A30R42	0698-0084	9	3	RESISTOR 2 15K 1% 125W F TC=0±100	24546	C4-1/8-T0-2151-F
A30R43	0698-3155	1		RESISTOR 4 64K 1% 125W F TC=0±100	24546	C4-1/8-T0-4641-F
A30R44	0698-0084	9		RESISTOR 2 15K 1% 125W F TC=0±100	24546	C4-1/8-T0-2151-F
A30R45	0698-0084	9		RESISTOR 2 15K 1% 125W F TC=0±100	24546	C4-1/8-T0-2151-F
A30R46	0757-0279	0		RESISTOR 3 16K 1% 125W F TC=0±100	24546	C4-1/8-T0-3161-F
A30R47	0757-0439	4	2	RESISTOR 6 81K 1% 125W F TC=0±100	24546	C4-1/8-T0-6811-F
A30R48	0757-0416	7		RESISTOR 51 1 1% 125W F TC=0±100	24546	C4-1/8-T0-511R-F
A30R49	0757-0279	0		RESISTOR 3 16K 1% 125W F TC=0±100	24546	C4-1/8-T0-3161-F
A30R50	0757-0439	4		RESISTOR 6 81K 1% 125W F TC=0±100	24546	C4-1/8-T0-6811-F
A30R51	0757-0416	7		RESISTOR 51 1 1% 125W F TC=0±100	24546	C4-1/8-T0-511R-F
A30R52	0757-0280	3	2	RESISTOR 1K 1% 125W F TC=0±100	24546	C4-1/8-T0-1001-F
A30R53	0757-0394	0		RESISTOR 51 1 1% 125W F TC=0±100	24546	C4-1/8-T0-51R1-F
A30R54	0757-0394	0		RESISTOR 51 1 1% 125W F TC=0±100	24546	C4-1/8-T0-51R1-F
A30R55	0757-0422	5		RESISTOR 909 1% 125W F TC=0±100	24546	C4-1/8-T0-909R-F
A30R56	0698-3150	6		RESISTOR 2 37K 1% 125W F TC=0±100	24546	C4-1/8-T0-2371-F
A30R57	0757-0401	0		RESISTOR 100 1% 125W F TC=0±100	24546	C4-1/8-T0-101-F
A30R58	0757-0401	0		RESISTOR 100 1% 125W F TC=0±100	24546	C4-1/8-T0-101-F
A30R59	0698-3150	6		RESISTOR 2 37K 1% 125W F TC=0±100	24546	C4-1/8-T0-2371-F
A30R60	0757-0280	3		RESISTOR 1K 1% 125W F TC=0±100	24546	C4-1/8-T0-1001-F
A30R61	0757-0397	3	1	RESISTOR 68 1 1% 125W F TC=0±100	24546	C4-1/8-T0-68R1-F
A30R62	0757-0401	0		RESISTOR 100 1% 125W F TC=0±100	24546	C4-1/8-T0-101-F
A30R63-66				NOT ASSIGNED		
A30R67*	0698-3437	2	2	RESISTOR 133 1% 125W F TC=0±100	24546	C4-1/8-T0-133R-F
A30R68*	0698-4037	0	1	RESISTOR 46 4 1% 125W F TC=0±100	24546	C4-1/8-T0-46R4-F
A30R69*	0698-3437	2		RESISTOR 133 1% 125W F TC=0±100	24546	C4-1/8-T0-133R-F
A30T1	08553-6012	5	3	TRANSFORMER-RF (BLUE)	28480	08553-6012
A30T2	08553-6012	5		TRANSFORMER-RF (BLUE)	28480	08553-6012
A30T3	08553-6012	5		TRANSFORMER-RF (BLUE)	28480	08553-6012
A30TP1				NOT ASSIGNED		
A30TP2	0360-0535	0	3	TERMINAL TEST POINT PCB	00000	ORDER BY DESCRIPTION
A30TP3	0360-0535	0		TERMINAL TEST POINT PCB	00000	ORDER BY DESCRIPTION
A30TP4	0360-0535	0		TERMINAL TEST POINT PCB	00000	ORDER BY DESCRIPTION
A30W1	08340-60102	2	1	CABLE ASSEMBLY-A30	28480	08340-60102
A30Y1	0410-1086	5	1	CRYSTAL-100 0 MHZ	28480	0410-1086

A31 M/N Phase Detector Circuit Description

ASSEMBLY PURPOSE

The M/N phase detector consists of a phase detector, a mixer, and two programmable frequency dividers (an M divider and an N divider). M and N dividers are integer dividers that give the ratio of divider input frequency to divider output frequency (i.e. the divide number). The N divider input is 20 MHz. The M divider input (5-45 MHz) is the difference frequency between the M/N Voltage Controlled Oscillator (VCO) (355-395 MHz) and 400 MHz. The two divider outputs are compared in a phase/frequency detector. The detector output is amplified and applied to the A33 M/N output assembly where it is used to tune the M/N VCO.

TTL ECL LEVEL TRANSLATORS (BLOCK A)

The TTL binary input to the frequency dividers comes from the A59 digital interface, and is shifted to ECL levels ($-0.7V$ logic high and $-1.7V$ logic low). N1 and M1 designate the least significant bits (LSB) for the N and M divider respectively.

N DIVIDER (BLOCK B) M DIVIDER (BLOCK C)

The M and N dividers are essentially identical in operation. In each, the input frequency is divided by the divide number (a binary coded number input from the digital interface board). The resulting output pulses are compared in frequency and phase to produce an error voltage that ultimately tunes the M/N VCO.

The following equations show the frequency relationship of the input and output of the dividers.

$$f_N = (4/N) (20 \text{ MHz})$$

$$f_M = (4/M) (f_{IF})$$

Where f_N = N divider output pulse repetition frequency (PRF) in MHz.

f_M = M divider output PRF in MHz.

N = N Divide Number

M = M Divide Number

f_{IF} = M Divider Clock frequency in MHz

20 MHz = N divider clock frequency

$f_N = f_M$ when the loop is phase locked

Therefore:

$$(4/N) (20 \text{ MHz}) = (4/M) (f_{IF})$$

and $f_{IF} = [(M/N) 20] \text{ MHz}$ for the phase locked condition

A. Counting Operation and Control. Refer to Figure A31-7 (schematic), Figure A31-2. Divider Operation, and Table A31-1. Divider Operation.

In the following example $N = 16$.

1. At the beginning of a divide sequence (clock 1), the four most significant bits (N_6, N_5, N_4, N_3) of the N number (0100XX) are loaded into programmable counter U6. (the two least significant bits, N_2 and N_1 are shown above as XX and are not used by U6. These two bits are used in the increment decoder, described in paragraph B, below.)
2. Clock 2 subtracts 4 (0001XX) from the previous total (0100XX), leaving (0011XX).
3. Clock 3 subtracts 4 more, and the output (0010XX) enables the end-of-count decoder, U9.
4. At clock 4, both the count control (U4B) and output flip-flop (U4A) are set. The count control output:
 - a. Inhibits the end-of-count decoder.
 - b. Causes U6 to enter its load mode.
 - c. Clock the divider flip-flop U10, which then sends a TTL logic high to the phase/frequency detector on the fourth clock pulse.
5. Clock 5 resets the flip-flops and loads the counter. This series of events repeats itself 3 more times for the $N=16$ sequence.

B. Increment Decoder Operation. The increment decoder and divider (U10) (divide-by-four) circuits function when the N number cannot be divided by four evenly. The 2 least significant bits of the N number (N_2 and N_1) control the output of the increment decoder. The divide-by-four circuit provides four sequential states that are input to the increment decoder. Each state coincides with one of the four count down sequences whose length is $N/4$ or $N/4 + 1$. Refer to Table A31-2, Increment Decoder Operation. Note that for the $N = 16$ sequence, $N_2 = N_1 = 0$. As explained in paragraph A, Counting Operation and Control, above, the increment decoder output sequence (TP3) never leaves the low state and the count down sequences are $N/4$. For $N = 19$ ($N_2 = N_1 = 1$) the first output is low with the remaining three high. This means that the first pulse occurs after $N/4$ clock Pulses and the other three occur after $N/4 + 1$ pulses. During the final three countdown sequences, the high at the increment decoder output inhibits U9B. This allows the counter to count down to 0001XX (rather than 0010XX) before the end-of-count decoder is enabled through U9A. This permits the extra count to occur. The rest of the sequence occurs as indicated in the previous section. See Figure A31-2 and Table A31-1 for divider operation with $N = 19$.

With the N input equal to or greater than 16, the N_5 or N_6 inputs are high and the divide-by-1 or 2 decoder is disabled. Thus the output flip-flop follows the count control flip-flop and each end-of-count pulse is passed directly to the output. If $N < 16$, then the divide-by-1 or 2 decoder is enabled and therefore passes every second end-of-count pulse to set the output flip-flop. Refer to Table A31-1 and Figure A31-1. This circuit reduces the apparent gain of the phase/frequency detector. This keeps the $\Delta F_{VCO}/\Delta V$ sensitivity of the VCO in a specific portion of its tuning curve thereby keeping the M/N loop bandwidth constant. Note that the N_5 and N_6 inputs are also connected to the M divider in the same manner as in the N divider. Note also that the frequency of the M and N divider outputs is halved for $N < 16$.

A31 M/N Phase Detector Circuit Description

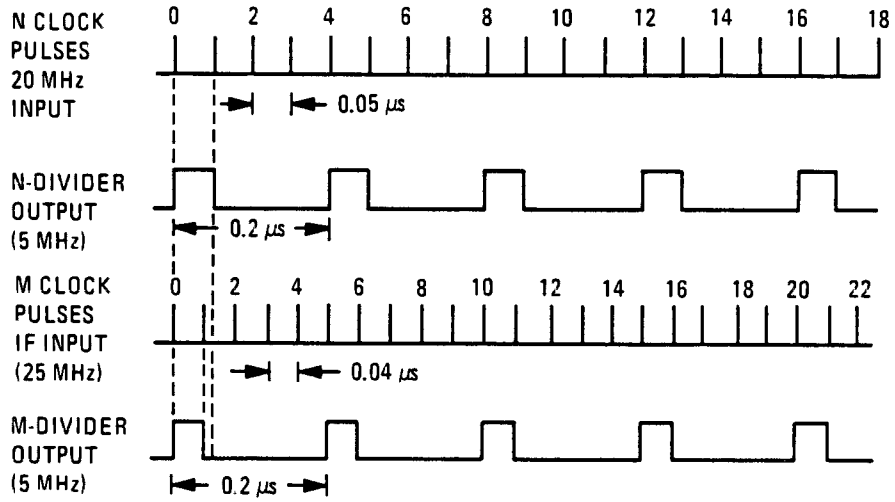

FREQUENCY AND TIME RELATIONSHIPS FOR N=16 AND M=20

Figure A31-1. Divider Clock Pulses Versus Output Pulses Frequency and Time Relationship.

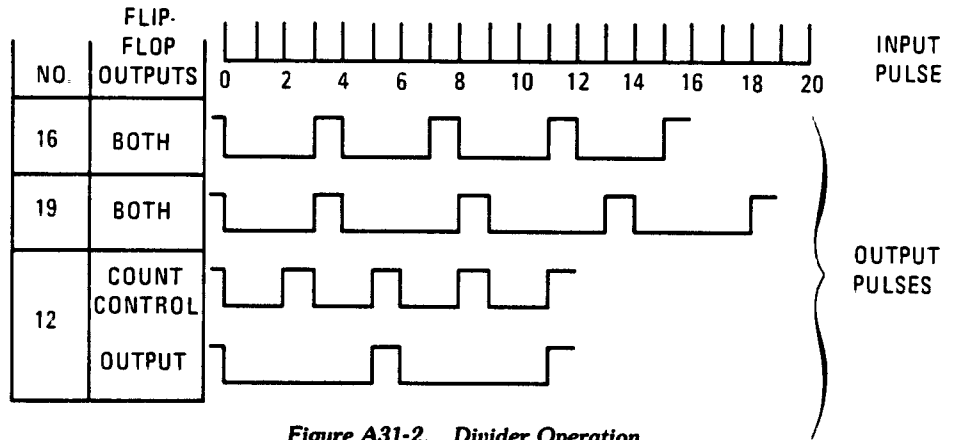

Figure A31-2. Divider Operation

A31 M/N Phase Detector Circuit Description

Table A31-1. Divider Operation

N	Input Clock Pulses	Operation	N number in Counter (4 MSB)	End of Count Decoder	Flip-Flop	
					Count Control	Output
16	0, 4, 8, 12	Load Counter	0100	Inactive	Reset	Reset
	1, 5, 9, 13	Minus 4	0011	Inactive	Reset	Reset
	2, 6, 10, 14	Minus 4	0010	Active	Reset	Reset
	3, 7, 11, 15	Minus 4	0001	Inactive	Set	Set
19	0, 4, 9, 14	Load Counter	0100	Inactive	Reset	Reset
	1, 5, 10, 15	Minus 4	0011	Inactive	Reset	Reset
	2, 6, 11, 16	Minus 4	0010	Inactive ¹	Reset	Reset
	3, 7, 12, 17	Minus 4	0001	Active ²	Reset ³	Reset ³
	8, 13, 18	Minus 4	0000	Inactive	Set	Set
12	0, 3, 6, 9	Load Counter	0011	Inactive	Reset	Reset
	1, 4, 7, 10	Minus 4	0010	Active	Reset	Reset
	2, 5, 8, 11	Minus 4	0001	Inactive	Set	Set ⁴

- 1 Active at clock pulse 3 only
- 2 Inactive at clock pulse 4 only
- 3 Set at clock pulse 4 only
- 4 The output flip-flop is set only every other time the counter control flip-flop is set for N<16.

Table A31-2. Increment Decoder Operation

Increment Decoder Control Inputs		Increment Decoder Output Sequence*			
N2	N1	1	2	3	4
L(0)	L(0)	L	L	L	L
L(0)	H(1)	L	L	H	L
H(1)	L(0)	L	H	L	H
H(1)	H(1)	L	H	H	H

* The sequence of four states is controlled by a modified ring counter made up of the two flip-flops contained in U10. Check the count sequence of U10 by verifying that the active high outputs of the flip-flops follow the sequence LL, HH, LH, and HL.

MIXER (BLOCK D)

The LO amplifier supplies approximately +5 dBm over a 355 to 395 MHz range to a mixer LO port. The reference loop (A30 100 MHz VCXO) supplies 400 MHz to the mixer RF port. The mixer IF output is the difference between 400 MHz and 355-395 MHz which gives an IF frequency of between 5 and 45 MHz at approximately -17 dBm.

IF AMPLIFIER (BLOCK E)

The 60 MHz low-pass filter rejects unwanted mixing products. The IF signal is amplified and limited. The output of the IF amplifier drives ECL circuitry (approximately -0.9V and -1.7V).

PHASE/FREQUENCY DETECTOR (BLOCK F)

The M and N divider outputs are compared in this block. When they are in phase, the outputs of block F are narrow, coincident pulses. For unlock conditions, the outputs pulses are of varying widths.

PREAMPLIFIER (BLOCK G)

The output of two low noise differential preamplifiers, TUNE (-) AND TUNE (+), are combined in the integrating amplifier of the A33 assembly.

PHASE LOCK INDICATOR (BLOCK H)

TUNE (-) and TUNE (+) from the preamplifier are compared to their average plus a small offset (provided by R29). If the loop unlocks, one of the preamplifier outputs, TUNE (-) or TUNE (+), is higher than the comparison voltage. The phase lock indicator goes high, indicating the unlock condition.

A31 M/N Phase Detector Component-Level Troubleshooting

INTRODUCTION

The A31 M/N Phase Detector mixes the A33 M/N VCO output (355 to 395 MHz) with the 400 MHz signal from the A30 M/N VCXO. The product of this mixing and the 20 MHz reference from the A29 Reference Phase Detector are then divided by M and N dividers respectively and their resultant outputs are compared by a phase/frequency detector. The resulting phase error is used to tune the A32 M/N VCO.

The two dividers (M and N) are identical in operation and their waveforms can be compared for troubleshooting purposes when the M and N numbers are set to the same value. If one of the dividers is known to be operating properly, comparisons of various test points within each divider will reveal a malfunction.

M DIVIDER (BLOCK B)

N DIVIDER (BLOCK C)

Press **[SHIFT] [M1]** to display the M and N divide numbers in the instrument's **POWER dBm** display. The M number is shown on the left, the N number on the right. Measurement instructions and waveforms for TP3 and TP7, TP5 and TP6, and TP1 and TP2 are shown in figures A31-3 through A31-5, below.

Oscilloscope control settings for Figures A31-3 through A31-5 are:

Vertical: 0.1V/Div
Horizontal: 0.2 μ sec/Div
Probe: 10:1

NOTE: All waveform voltage levels are emitter coupled logic (ECL) levels; $-0.9V = \text{High}$, $-1.7V = \text{Low}$.

A31 M/N Phase Detector Component-Level Troubleshooting

Set the instrument M and N divide numbers to 20:

Press: [CW] [3] [.] [7] [7] [GHz] LEVELS = ECL LOW = -1.7V

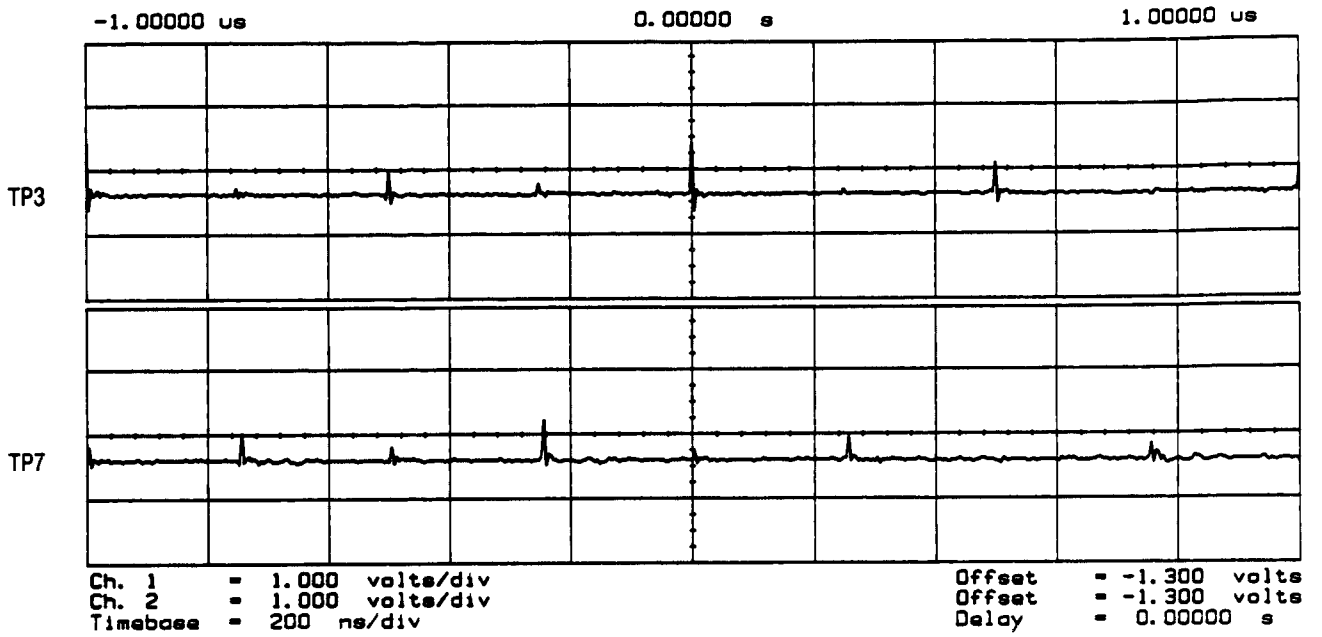

Set the instrument M and N divide numbers to 21:

Press: [CW] [3] [.] [9] [6] [GHz] DUTY CYCLE < 1/3

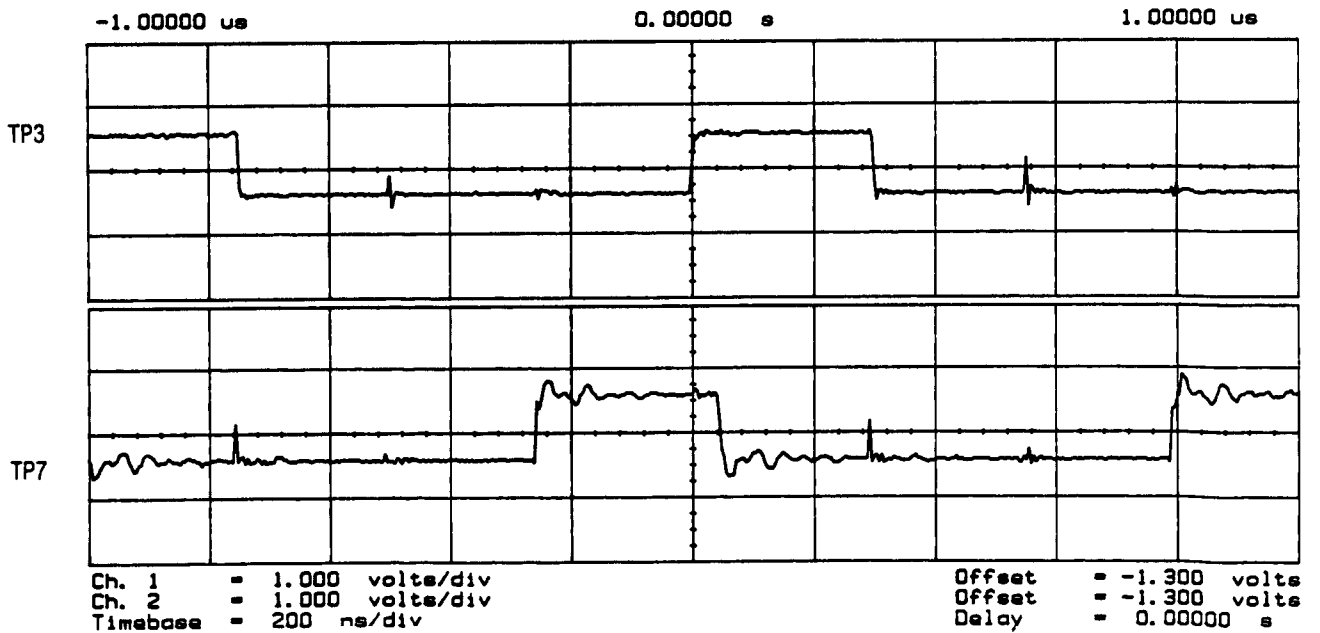
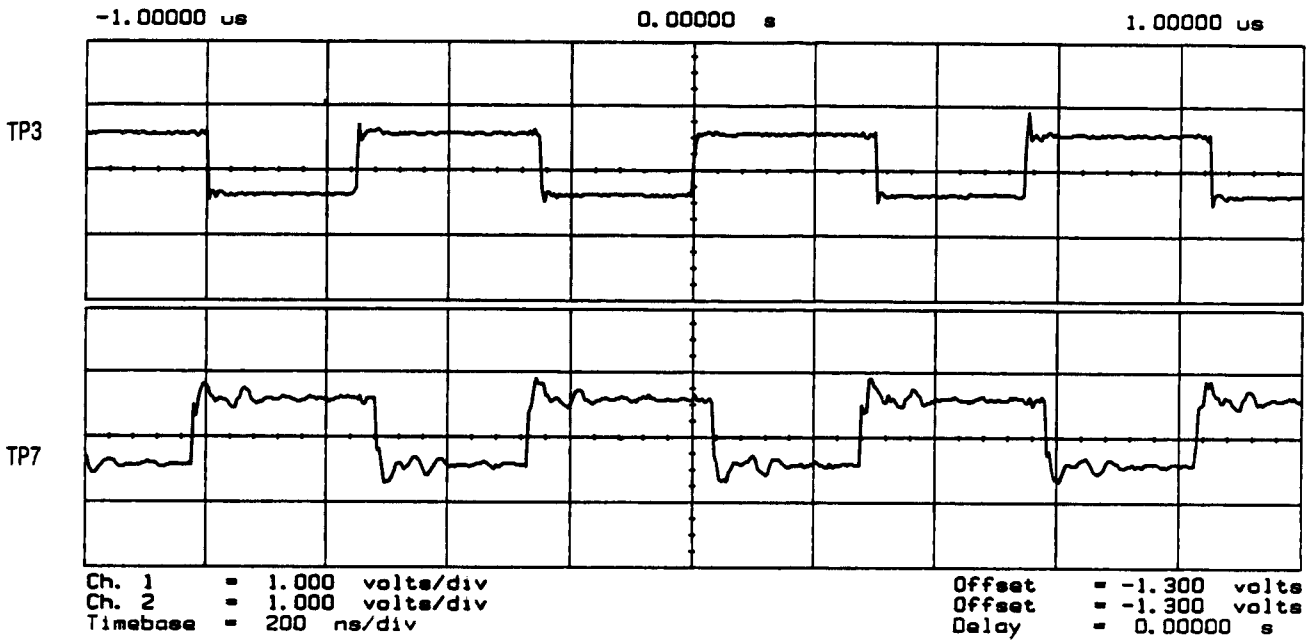

Figure A31-3. M and N Divider Waveforms for Test Points 3 and 7 (1 of 2).

A31 M/N Phase Detector Component-Level Troubleshooting

Set the instrument M and N divide numbers to 22:

Press: [CW] [4] [.] [1] [5] [GHz] DUTY CYCLE \cong 1/2



Set the instrument M and N divide numbers to 23:

Press: [CW] [4] [.] [3] [4] [GHz] DUTY CYCLE $>$ 2/3

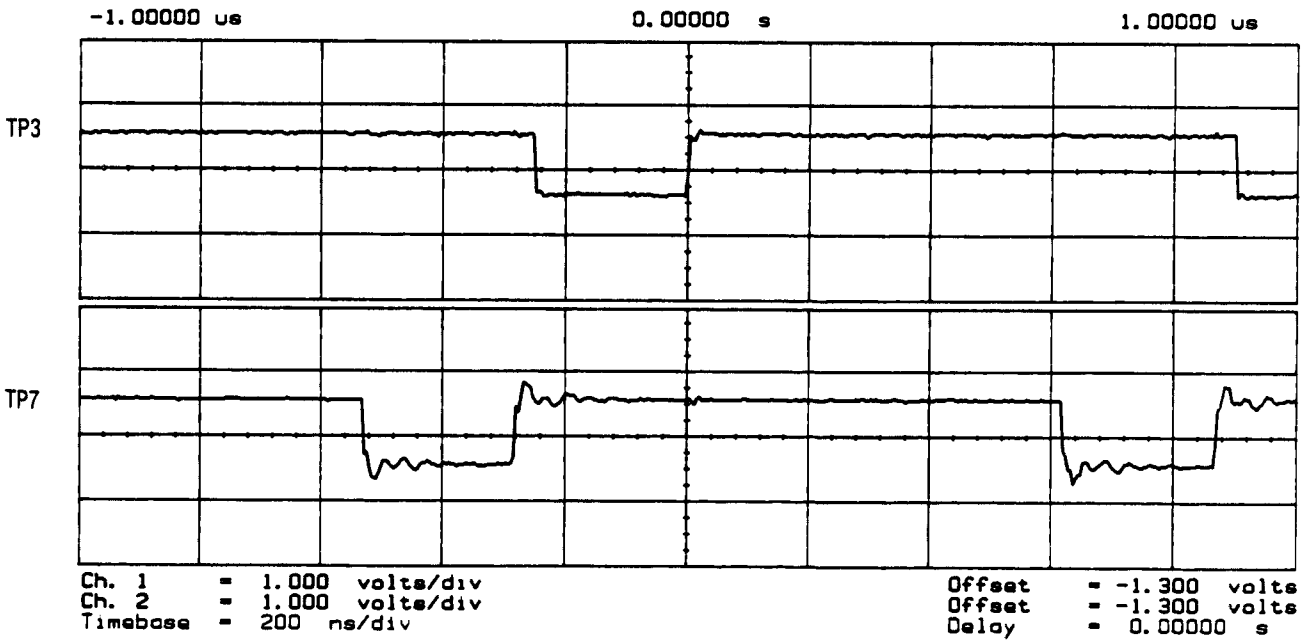

Figure A31-3. M and N Divider Waveforms for Test Points 3 and 7 (2 of 2).

Set the instrument M and N divide numbers to 22:

Press: [CW] [4] [.] [1] [5] [GHz] DUTY CYCLE \cong 1/2

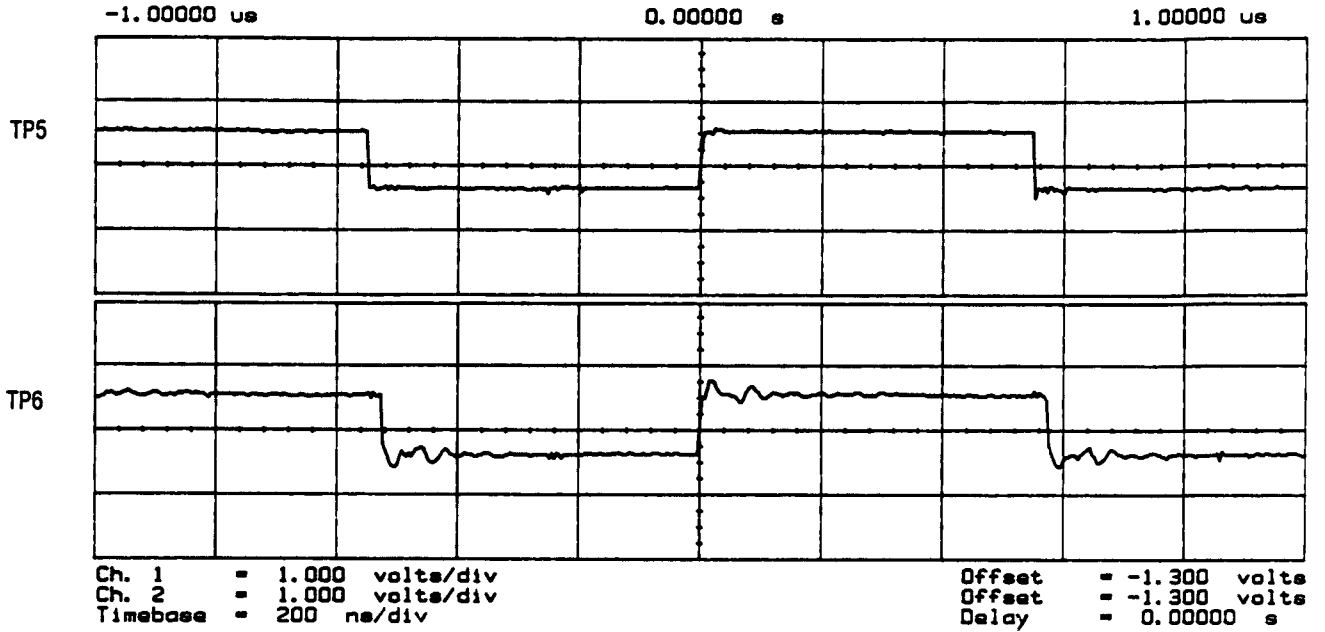

Figure A31-4. M and N Divider Waveforms for Test Points 5 and 6.

Set the instrument M and N divide numbers to 22:

Press: [CW] [4] [.] [1] [5] [GHz] TP1

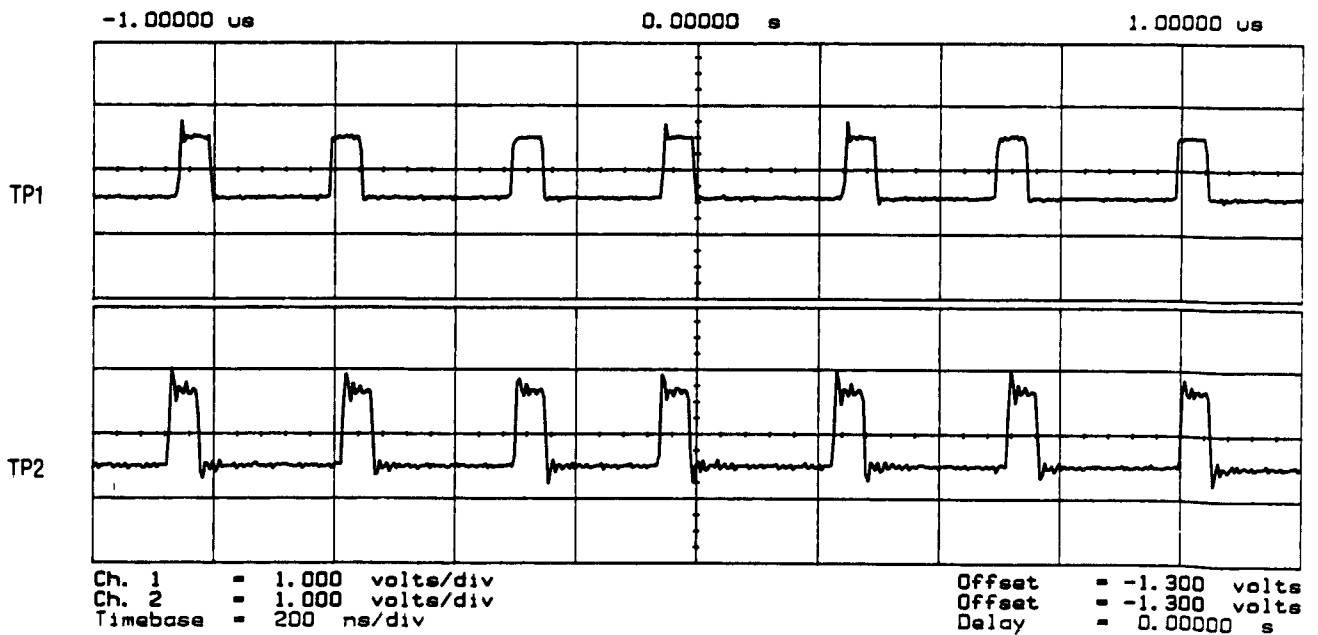

Figure A31-5. M and N Divider Waveforms for Test Points 1 and 2.

NOTE: To select specific M numbers, change the instrument's CW frequency in 10 MHz steps. This will increment or decrement M. To select a specific N number, change the instrument's CW frequency in 200 MHz steps.

**MIXER (BLOCK D)
IF AMPLIFIER (BLOCK E)**

The mixer inputs are 400 MHz from A30 100 MHz VCXO, and 355 to 395 MHz from the M/N Output. When the M and N numbers are the same, the M/N output frequency is 380 MHz.

The output of the IF amplifier and U18 Pin 3 is at ECL logic levels; $-0.9V = \text{High}$, $-1.7V = \text{Low}$. Typical voltage levels for Q3 and Q4 are shown in Table A31-3

Table A31-3. IF Amplifier Voltage Levels

	Voltage Levels	
	Q3	Q4
	Emitter	-5.6V
Base	-4.8V	-6.6V
Collector	0.0V	-1.9V

**PHASE/FREQUENCY DETECTOR (BLOCK F)
PREAMPLIFIER (BLOCK G)**

The phase/frequency detector outputs pulses whose width is proportional to the phase difference of the two input signals. These pulses are filtered by the combination of R24/C5 and R25/C6. The preamplifier amplifies the pulses, which are representative of the phase difference of the two input signals. Typical voltage levels for the preamplifier are shown in Table A31-4.

Table A31-4. Typical Preamplifier Voltage Levels

Transistor	Voltage Levels			
	Phase Locked	No Input At		
		J1	J2	J3
Q1				
Emitter	-1.0V	-1.0V	-1.0V	-1.0V
Base	-1.7V	-0.8V	-1.7V	-0.8V
Collector	-4.8V	-7.9V	-1.8V	-7.9V
Q2				
Emitter	-1.0V	-1.0V	-1.0V	-1.0V
Base	-1.7V	-1.7V	-0.8V	-1.7V
Collector	-4.8V	-1.8V	-7.9V	-1.8V

PHASE LOCK DETECTOR (BLOCK H)

The outputs of the preamplifier are compared to a reference voltage of $-4V$ by U2A and U2B. The output (HULM) is high when the loop is unlocked.

To check this disconnect the 400 MHz input at A31J1 and measure the output of U2 (P1-26). With the loop unlocked (400 MHz removed), this voltage should be approximately $+4.64$ volts.

Table A31-5. A31 M/N Phase Detector, Pin I/O

Pin	Mnemonic	Levels	Source	Destination
1 16	$-10V$ $-10V$	$-10V$ $-10V$	XA34P2-8, 9 XA34P2-8, 9	*I *I
2 17	$+20V$ $+20V$	$+20V$ $+20V$	XA34P2-2,3 XA34P2-2, 3	*I *I
3 18	$-5.2V$ $-5.2V$	$-5.2V$ $-5.2V$	XA34P2-12, 13 XA34P2-13, 13	*I *I
4 19	GND GND	0V 0V	INSTRUMENT GROUND INSTRUMENT GROUND	*I *I
5 20	GND GND	0V 0V	INSTRUMENT GROUND INSTRUMENT GROUND	*I *I
6 21	VCO TUNE (-) VCO TUNE (+)		G G	* *
7 22	GND GND	0V 0V	INSTRUMENT GROUND INSTRUMENT GROUND	*I *I
8 23	N1 N2	TTL TTL	XA34P1-15 XA34P1-14	A A
9 24	N5 N6	TTL TTL	XA34P1-11 XA34P1-10	A A
10 25	N3 N4	TTL TTL	XA34P1-13 XA34P1-12	A A
11 26	GND HULM	0V TTL (HIGH TRUE)	INSTRUMENT GROUND H	*I XA34P1-8
12 27	GND GND	0V 0V	INSTRUMENT GROUND INSTRUMENT GROUND	*I *I
13 28	M1 M2	TTL (HIGH TRUE) TTL (HIGH TRUE)	XA34P1-5 XA34P1-6	A A
14 29	M3 M4	TTL (HIGH TRUE) TTL (HIGH TRUE)	XA34P1-3 XA34P1-4	A A
15 30	M5 LMNE	TTL HIGH TRUE TTL (LOW TRUE)	XA34P1-1 XA34P1-2	A NOT USED

A single letter in the source or destination column refers to a function block on this assembly schematic.

An asterisk (*) denotes multiple sources or destinations; refer to the A34 Reference Loop - M/N Motherboard Schematic Diagram for a complete representation of signal sources and destinations

A31 M/N Phase Detector Component-Level Troubleshooting

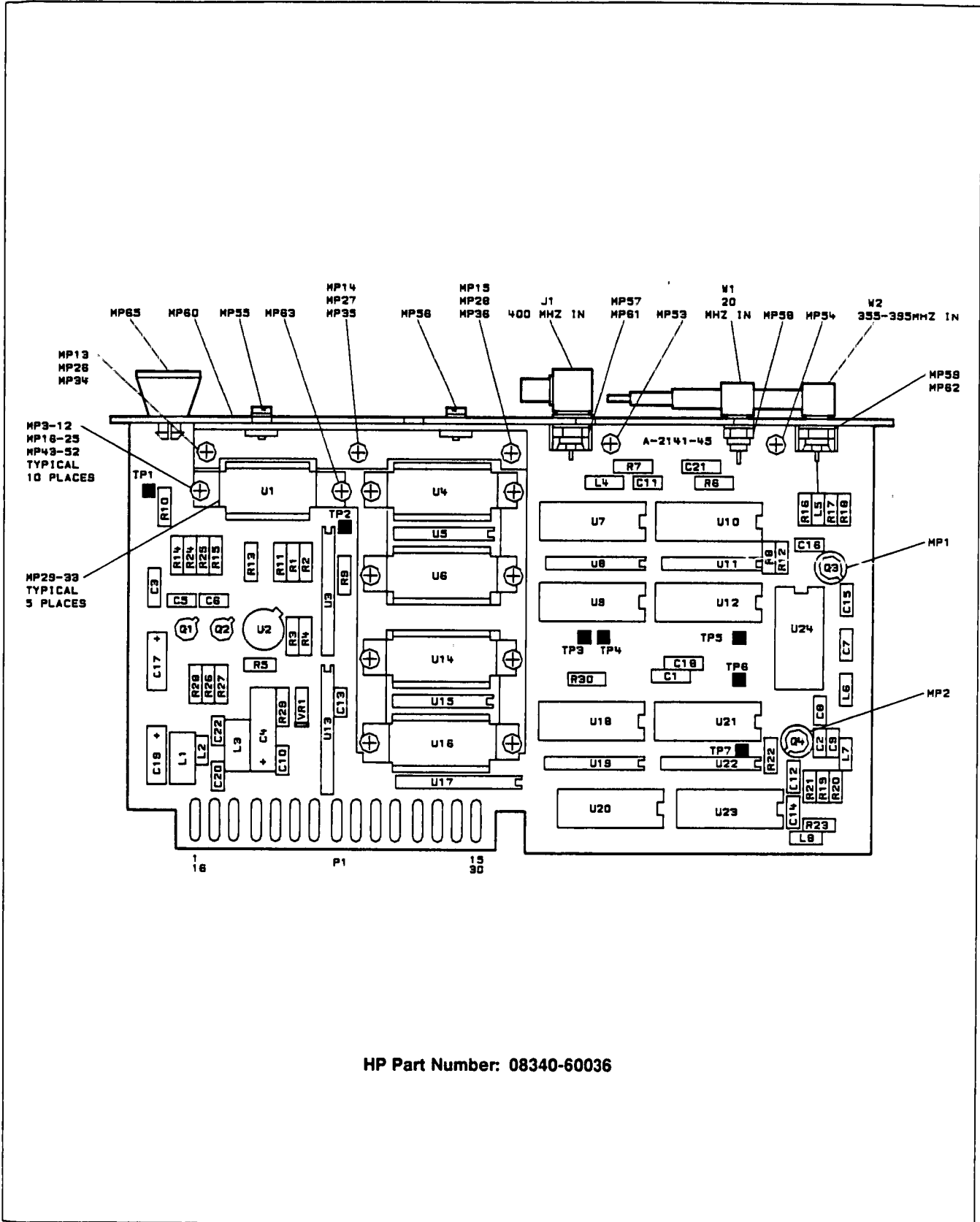
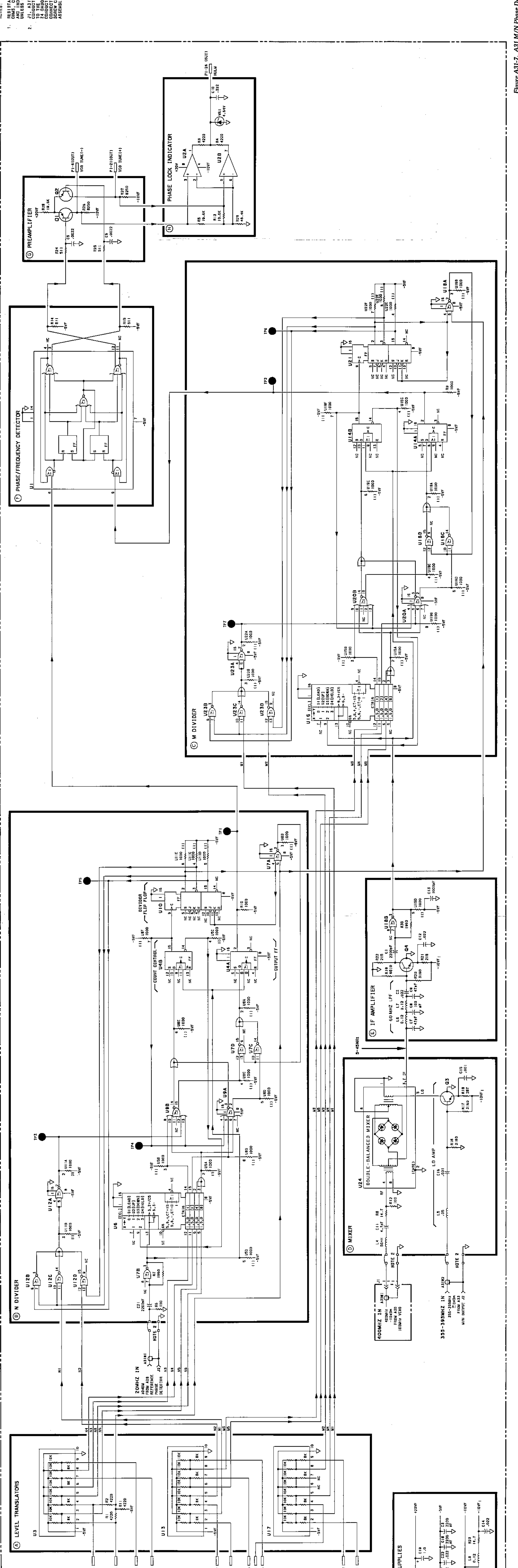

Figure A31-6. A31 M/N Phase Detector Component Location Diagram

A31 M/N PHASE DETECTOR
CBS40-6035



- NOTES:
1. RESISTANCE VALUES SHOWN ARE IN OHMS UNLESS OTHERWISE NOTED.
 2. J1, A31W1, AND A31W2 CENTER TERMINALS CONNECTED TO THE 75 OHM WIRE THROUGH THE COVER TO THE 75 OHM BOARD THROUGH THE COVER SCREW CONNECTIONS THROUGH MECHANICAL ASSEMBLY COVER PLATE.

Figure A31-7. A31 M/N Phase Detector, Schematic Diagram
Reference Loop - M/N Loop A31-15/A31-14

A31 M/N Phase Detector Component-Level Troubleshooting

Table A31-6. A31 M/N Phase Detector Replaceable Parts

Reference Designation	HP Part Number	C D	Qty	Description	Mfr Code	Mfr Part Number
A31	08340-60036	1	1	M/N PHASE DETECTOR	28480	08340-60036
A31C1	0160-4299	7	4	CAPACITOR-FXD 2200PF ±20% 250VDC CER	56289	C067F251F222MS22-CDH
A31C2	0160-0574	3	6	CAPACITOR-FXD 022UF ±20% 100VDC CER	28480	0160-0574
A31C3	0160-4299	7		CAPACITOR-FXD 2200PF ±20% 250VDC CER	56289	C067F251F222MS22-CDH
A31C4	0180-0100	3	1	CAPACITOR-FXD 4.7UF ±10% 35VDC TA	56289	150D475X9035B2
A31C5	0160-0572	1	2	CAPACITOR-FXD 2200PF ±20% 100VDC CER	28480	0160-0572
A31C6	0160-0572	1		CAPACITOR-FXD 2200PF ±20% 100VDC CER	28480	0160-0572
A31C7	0160-3876	4	2	CAPACITOR-FXD 47PF ±20% 200VDC CER	28480	0160-3876
A31C8	0160-3877	5	1	CAPACITOR-FXD 100PF ±20% 200VDC CER	28480	0160-3877
A31C9	0160-3876	4		CAPACITOR-FXD 47PF ±20% 200VDC CER	28480	0160-3876
A31C10	0160-0574	3		CAPACITOR-FXD 022UF ±20% 100VDC CER	28480	0160-0574
A31C11	0160-3873	1	1	CAPACITOR-FXD 4.7PF ± 5PF 200VDC CER	28480	0160-3873
A31C12	0160-0574	3		CAPACITOR-FXD 022UF ±20% 100VDC CER	28480	0160-0574
A31C13	0160-3878	6	3	CAPACITOR-FXD 1000PF ±20% 100VDC CER	28480	0160-3878
A31C14	0160-0574	3		CAPACITOR-FXD 022UF ±20% 100VDC CER	28480	0160-0574
A31C15	0160-3878	6		CAPACITOR-FXD 1000PF ±20% 100VDC CER	28480	0160-3878
A31C16	0160-3878	6		CAPACITOR-FXD 1000PF ±20% 100VDC CER	28480	0160-3878
A31C17	0180-0197	8	1	CAPACITOR-FXD 2.2UF ±10% 20VDC TA	56289	150D225X9020A2
A31C18	0160-4299	7		CAPACITOR-FXD 2200PF ±20% 250VDC CER	56289	C067F251F222MS22-CDH
A31C19	0180-0291	3	1	CAPACITOR-FXD 1UF ±10% 35VDC TA	56289	150D105X9035A2
A31C20	0160-0574	3		CAPACITOR-FXD 022UF ±20% 100VDC CER	28480	0160-0574
A31C21	0160-4299	7		CAPACITOR-FXD 2200PF ±20% 250VDC CER	56289	C067F251F222MS22-CDH
A31C22	0160-0574	3		CAPACITOR-FXD 022UF ±20% 100VDC CER	28480	0160-0574
A31J1	1250-0690	6	1	CONNECTOR-RF MALE SMB	28480	1250-0690
A31L1	9100-1641	0	2	INDUCTOR RF-CH-MLD 240UH 5% 166DX 385LG	28480	9100-1641
A31L2	9100-2259	8	1	INDUCTOR RF-CH-MLD 1.5UH 10% .105DX 26LG	28480	9100-2259
A31L3	9100-1641	0		INDUCTOR RF-CH-MLD 240UH 5% 166DX 385LG	28480	9100-1641
A31L4	9100-2891	4	1	INDUCTOR RF-CH-MLD 50NH 10% 105DX 26LG	28480	9100-2891
A31L5				NOT ASSIGNED		
A31L6	9100-2248	5	3	INDUCTOR RF-CH-MLD 120NH 10% 105DX 26LG	28480	9100-2248
A31L7	9100-2248	5		INDUCTOR RF-CH-MLD 120NH 10% 105DX 26LG	28480	9100-2248
A31L8	9100-2248	5		INDUCTOR RF-CH-MLD 120NH 10% 105DX 26LG	28480	9100-2248
A31MP1, 2				NOT ASSIGNED		
A31MP3	0520-0129	8	13	SCREW-MACH 2-56 312-IN-LG PAN-HD-POZI	00000	ORDER BY DESCRIPTION
A31MP4	0520-0129	8		SCREW-MACH 2-56 312-IN-LG PAN-HD-POZI	00000	ORDER BY DESCRIPTION
A31MP5	0520-0129	8		SCREW-MACH 2-56 312-IN-LG PAN-HD-POZI	00000	ORDER BY DESCRIPTION
A31MP6	0520-0129	8		SCREW-MACH 2-56 312-IN-LG PAN-HD-POZI	00000	ORDER BY DESCRIPTION
A31MP7	0520-0129	8		SCREW-MACH 2-56 312-IN-LG PAN-HD-POZI	00000	ORDER BY DESCRIPTION
A31MP8	0520-0129	8		SCREW-MACH 2-56 312-IN-LG PAN-HD-POZI	00000	ORDER BY DESCRIPTION
A31MP9	0520-0129	8		SCREW-MACH 2-56 312-IN-LG PAN-HD-POZI	00000	ORDER BY DESCRIPTION
A31MP10	0520-0129	8		SCREW-MACH 2-56 312-IN-LG PAN-HD-POZI	00000	ORDER BY DESCRIPTION
A31MP11	0520-0129	8		SCREW-MACH 2-56 312-IN-LG PAN-HD-POZI	00000	ORDER BY DESCRIPTION
A31MP12	0520-0129	8		SCREW-MACH 2-56 312-IN-LG PAN-HD-POZI	00000	ORDER BY DESCRIPTION
A31MP13	0520-0129	8		SCREW-MACH 2-56 312-IN-LG PAN-HD-POZI	00000	ORDER BY DESCRIPTION
A31MP14	0520-0129	8		SCREW-MACH 2-56 312-IN-LG PAN-HD-POZI	00000	ORDER BY DESCRIPTION
A31MP15	0520-0129	8		SCREW-MACH 2-56 312-IN-LG PAN-HD-POZI	00000	ORDER BY DESCRIPTION
A31MP16	0590-0533	5		THREADED INSERT-NUT 2-56 06-IN-LG SST	28480	0590-0533
A31MP17	0590-0533	5		THREADED INSERT-NUT 2-56 06-IN-LG SST	28480	0590-0533
A31MP18	0590-0533	5		THREADED INSERT-NUT 2-56 06-IN-LG SST	28480	0590-0533
A31MP19	0590-0533	5		THREADED INSERT-NUT 2-56 06-IN-LG SST	28480	0590-0533
A31MP20	0590-0533	5		THREADED INSERT-NUT 2-56 06-IN-LG SST	28480	0590-0533
A31MP21	0590-0533	5		THREADED INSERT-NUT 2-56 06-IN-LG SST	28480	0590-0533
A31MP22	0590-0533	5		THREADED INSERT-NUT 2-56 06-IN-LG SST	28480	0590-0533
A31MP23	0590-0533	5		THREADED INSERT-NUT 2-56 06-IN-LG SST	28480	0590-0533
A31MP24	0590-0533	5		THREADED INSERT-NUT 2-56 06-IN-LG SST	28480	0590-0533
A31MP25	0590-0533	5		THREADED INSERT-NUT 2-56 06-IN-LG SST	28480	0590-0533
A31MP26	0590-0533	5		THREADED INSERT-NUT 2-56 06-IN-LG SST	28480	0590-0533

A31 M/N Phase Detector Component-Level Troubleshooting

Table A31-6. A31 M/N Phase Detector Replaceable Parts

Reference Designation	HP Part Number	C D	Qty	Description	Mfr Code	Mfr Part Number
A31MP27	0590-0533	5		THREADED INSERT-NUT 2-56 06-IN-LG SST	28480	0590-0533
A31MP28	0590-0533	5		THREADED INSERT-NUT 2-56 06-IN-LG SST	28480	0590-0533
A31MP29	1205-0285	0	5	HEAT SINK SGL DIP	28480	1205-0285
A31MP30	1205-0285	0		HEAT SINK SGL DIP	28480	1205-0285
A31MP31	1205-0285	0		HEAT SINK SGL DIP	28480	1205-0285
A31MP32	1205-0285	0		HEAT SINK SGL DIP	28480	1205-0285
A31MP33	1205-0285	0		HEAT SINK SGL DIP	28480	1205-0285
A31MP34	2190-0014	1	3	WASHER-LK INTL T NO 2 089-IN-ID	28480	2190-0014
A31MP35	2190-0014	1		WASHER-LK INTL T NO 2 089-IN-ID	28480	2190-0014
A31MP36	2190-0014	1		WASHER-LK INTL T NO 2 089-IN-ID	28480	2190-0014
A31MP37	2190-0124	4	6	WASHER-LK INTL T NO 10 195-IN-ID	28480	2190-0124
A31MP38	2190-0124	4		WASHER-LK INTL T NO 10 195-IN-ID	28480	2190-0124
A31MP39	2190-0124	4		WASHER-LK INTL T NO 10 195-IN-ID	28480	2190-0124
A31MP40	2190-0124	4		WASHER-LK INTL T NO 10 195-IN-ID	28480	2190-0124
A31MP41	2190-0124	4		WASHER-LK INTL T NO 10 195-IN-ID	28480	2190-0124
A31MP42	2190-0124	4		WASHER-LK INTL T NO 10 195-IN-ID	28480	2190-0124
A31MP43	2190-0890	1	10	WASHER-LK HLCL NO 2 088-IN-ID	28480	2190-0890
A31MP44	2190-0890	1		WASHER-LK HLCL NO 2 088-IN-ID	28480	2190-0890
A31MP45	2190-0890	1		WASHER-LK HLCL NO 2 088-IN-ID	28480	2190-0890
A31MP46	2190-0890	1		WASHER-LK HLCL NO 2 088-IN-ID	28480	2190-0890
A31MP47	2190-0890	1		WASHER-LK HLCL NO 2 088-IN-ID	28480	2190-0890
A31MP48	2190-0890	1		WASHER-LK HLCL NO 2 088-IN-ID	28480	2190-0890
A31MP49	2190-0890	1		WASHER-LK HLCL NO 2 088-IN-ID	28480	2190-0890
A31MP50	2190-0890	1		WASHER-LK HLCL NO 2 088-IN-ID	28480	2190-0890
A31MP51	2190-0890	1		WASHER-LK HLCL NO 2 088-IN-ID	28480	2190-0890
A31MP52	2190-0890	1		WASHER-LK HLCL NO 2 088-IN-ID	28480	2190-0890
A31MP53	2200-0101	0	2	SCREW-MACH 4-40 188-IN-LG PAN-HD-POZI	00000	ORDER BY DESCRIPTION
A31MP54	2200-0101	0		SCREW-MACH 4-40 188-IN-LG PAN-HD-POZI	00000	ORDER BY DESCRIPTION
A31MP55	2200-0103	2	2	SCREW-MACH 4-40 25-IN-LG PAN-HD-POZI	00000	ORDER BY DESCRIPTION
A31MP56	2200-0103	2		SCREW-MACH 4-40 25-IN-LG PAN-HD-POZI	00000	ORDER BY DESCRIPTION
A31MP57	2950-0078	9	3	NUT-HEX-DBL-CHAM 10-32-THD 067-IN-THK	28480	2950-0078
A31MP58	2950-0078	9		NUT-HEX-DBL-CHAM 10-32-THD 067-IN-THK	28480	2950-0078
A31MP59	2950-0078	9		NUT-HEX-DBL-CHAM 10-32-THD 067-IN-THK	28480	2950-0078
A31MP60	08340-20092	5	1	COVER-PC M/N PHASE DETECTOR	28480	08340-20092
A31MP61	85660-20068	4	2	GROUND LUG	28480	85660-20068
A31MP62	85660-20068	4		GROUND LUG	28480	85660-20068
A31MP63	86701-00032	2	1	HEAT SINK-IC	28480	86701-00032
A31MP64	86701-00033	3	1	BRACKET-HEAT SINK	28480	86701-00033
A31MP65	86701-40001	9	1	EXTRACTOR-PC BOARD	28480	86701-40001
A31MP66	1200-0172	4	1	INSULATOR-XSTR DAP-GL	28480	1200-0172
A31Q1	1853-0451	5	2	TRANSISTOR PNP 2N3799 SI TO-18 PD=360MW	01295	2N3799
A31Q2	1853-0451	5		TRANSISTOR PNP 2N3799 SI TO-18 PD=360MW	01295	2N3799
A31Q3	1854-0345	8	2	TRANSISTOR NPN 2N5179 SI TO-72 PD=200MW	04713	2N5179
A31Q4	1854-0345	8		TRANSISTOR NPN 2N5179 SI TO-72 PD=200MW	04713	2N5179
A31R1	0698-3154	0	5	RESISTOR 4.22K 1% 125W F TC=0±100	24546	C4-1/8-T0-4221-F
A31R2	0698-3154	0		RESISTOR 4.22K 1% 125W F TC=0±100	24546	C4-1/8-T0-4221-F
A31R3	0698-3154	0		RESISTOR 4.22K 1% 125W F TC=0±100	24546	C4-1/8-T0-4221-F
A31R4	0698-3154	0		RESISTOR 4.22K 1% 125W F TC=0±100	24546	C4-1/8-T0-4221-F
A31R5	0698-7267	4	1	RESISTOR 19.6K 1% 05W F TC=0±100	24546	C3-1/8-T0-1962-F
A31R6	0757-0401	0	1	RESISTOR 100 1% 125W F TC=0±100	24546	C4-1/8-T0-101-F
A31R7	0698-0083	8	2	RESISTOR 1.96K 1% 125W F TC=0±100	24546	C4-1/8-T0-1961-F
A31R8	0698-7192	4	2	RESISTOR 14.7 1% 05W F TC=0±100	24546	C3-1/8-T0-14R7-F
A31R9	0757-0280	3	2	RESISTOR 1K 1% 125W F TC=0±100	24546	C4-1/8-T0-1001-F
A31R10	0757-0280	3		RESISTOR 1K 1% 125W F TC=0±100	24546	C4-1/8-T0-1001-F

A31 M/N Phase Detector Component-Level Troubleshooting

Table A31-6. A31 M/N Phase Detector Replaceable Parts

Reference Designation	HP Part Number	C D	Qty	Description	Mfr Code	Mfr Part Number
A31R11	0698-3154	0		RESISTOR 4.22K 1% 125W F TC=0±100	24546	C4-1/8-T0-4221-F
A31R12	0698-7212	9	1	RESISTOR 100 1% 05W F TC=0±100	24546	C3-1/8-T0-100R-F
A31R13	0698-3157	3	2	RESISTOR 19.6K 1% 125W F TC=0±100	24546	C4-1/8-T0-1962-F
A31R14	0757-0416	7	4	RESISTOR 511 1% 125W F TC=0±100	24546	C4-1/8-T0-511R-F
A31R15	0757-0416	7		RESISTOR 511 1% 125W F TC=0±100	24546	C4-1/8-T0-511R-F
A31R16	0698-7248	1	3	RESISTOR 3.16K 1% 05W F TC=0±100	24546	C3-1/8-T0-3161-F
A31R17	0698-7248	1		RESISTOR 3.16K 1% 05W F TC=0±100	24546	C3-1/8-T0-3161-F
A31R18	0698-7223	2	1	RESISTOR 287 1% 05W F TC=0±100	24546	C3-1/8-T0-287R-F
A31R19	0698-7256	1	1	RESISTOR 6.81K 1% 05W F TC=0±100	24546	C3-1/8-T0-6811-F
A31R20	0698-7248	1		RESISTOR 3.16K 1% 05W F TC=0±100	24546	C3-1/8-T0-3161-F
A31R21	0698-7220	9	2	RESISTOR 215 1% 05W F TC=0±100	24546	C3-1/8-T0-215R-F
A31R22	0698-7220	9		RESISTOR 215 1% 05W F TC=0±100	24546	C3-1/8-T0-215R-F
A31R23	0698-7192	4		RESISTOR 14.7 1% 05W F TC=0±100	24546	C3-1/8-T0-14R7-F
A31R24	0757-0416	7		RESISTOR 511 1% 125W F TC=0±100	24546	C4-1/8-T0-511R-F
A31R25	0757-0416	7		RESISTOR 511 1% 125W F TC=0±100	24546	C4-1/8-T0-511R-F
A31R26	0757-0441	8	2	RESISTOR 8.25K 1% 125W F TC=0±100	24546	C4-1/8-T0-8251-F
A31R27	0757-0441	8		RESISTOR 8.25K 1% 125W F TC=0±100	24546	C4-1/8-T0-8251-F
A31R28	0698-3157	3		RESISTOR 19.6K 1% 125W F TC=0±100	24546	C4-1/8-T0-1962-F
A31R29	0698-3162	0	1	RESISTOR 46.4K 1% 125W F TC=0±100	24546	C4-1/8-T0-4642-F
A31R30	0698-0083	8		RESISTOR 1.96K 1% 125W F TC=0±100	24546	C4-1/8-T0-1961-F
A31TP1	0360-0535	0	7	TERMINAL TEST POINT PCB	00000	ORDER BY DESCRIPTION
A31TP2	0360-0535	0		TERMINAL TEST POINT PCB	00000	ORDER BY DESCRIPTION
A31TP3	0360-0535	0		TERMINAL TEST POINT PCB	00000	ORDER BY DESCRIPTION
A31TP4	0360-0535	0		TERMINAL TEST POINT PCB	00000	ORDER BY DESCRIPTION
A31TP5	0360-0535	0		TERMINAL TEST POINT PCB	00000	ORDER BY DESCRIPTION
A31TP6	0360-0535	0		TERMINAL TEST POINT PCB	00000	ORDER BY DESCRIPTION
A31TP7	0360-0535	0		TERMINAL TEST POINT PCB	00000	ORDER BY DESCRIPTION
A31U1	1820-1344	8	1	IC PL LOOP 14-DIP-C PKG	04713	MC12040L
A31U2	1826-0092	3	1	IC OP AMP GP DUAL TO-99 PKG	28480	1826-0092
A31U3	1810-0251	3	3	NETWORK-RES 10-SIP MULTI-VALUE	28480	1810-0251
A31U4	1820-1225	4	2	IC FF ECL D-M/S DUAL	04713	MC10231P
A31U5	1810-0204	6	6	NETWORK-RES 8-SIP1 0K OHM X 7	01121	208A102
A31U6	1820-0821	4	2	IC CNTR ECL BIN UP/DOWN SYNCHRO	28480	1820-0821
A31U7	1820-0802	1	4	IC GATE ECL NOR QUAD 2-INP	04713	MC10102P
A31U8	1810-0204	6		NETWORK-RES 8-SIP1 0K OHM X 7	01121	208A102
A31U9	1820-0806	5	2	IC GATE ECL OR-NOR DUAL 4-5-INP	04713	MC10109P
A31U10	1820-0820	3	2	IC FF ECL J-BAR K-BAR COM CLOCK DUAL	04713	MC10135L
A31U11	1810-0204	6		NETWORK-RES 8-SIP1 0K OHM X 7	01121	208A102
A31U12	1820-0802	1		IC GATE ECL NOR QUAD 2-INP	04713	MC10102P
A31U13	1810-0251	3		NETWORK-RES 10-SIP MULTI-VALUE	28480	1810-0251
A31U14	1820-1225	4		IC FF ECL D-M/S DUAL	04713	MC10231P
A31U15	1810-0204	6		NETWORK-RES 8-SIP1 0K OHM X 7	01121	208A102
A31U16	1820-0821	4		IC CNTR ECL BIN UP/DOWN SYNCHRO	28480	1820-0821
A31U17	1810-0251	3		NETWORK-RES 10-SIP MULTI-VALUE	28480	1810-0251
A31U18	1820-0802	1		IC GATE ECL NOR QUAD 2-INP	04713	MC10102P
A31U19	1810-0204	6		NETWORK-RES 8-SIP1 0K OHM X 7	01121	208A102
A31U20	1820-0806	5		IC GATE ECL OR-NOR DUAL 4-5-INP	04713	MC10109P

A31 M/N Phase Detector Component-Level Troubleshooting

Table A31-6. A31 M/N Phase Detector Replaceable Parts

Reference Designation	HP Part Number	C D	Qty	Description	Mfr Code	Mfr Part Number
A31U21	1820-0820	3		IC FF ECL J-BAR K-BAR COM CLOCK DUAL	04713	MC10135L
A31U22	1810-0204	6		NETWORK-RES 8-SIP1.0K OHM X 7	01121	208A102
A31U23	1820-0802	1		IC GATE ECL NOR QUAD 2-INP	04713	MC10102P
A31U24	0955-0063	0	1	MIXER-DOUBLER 5-500 MH	28480	0955-0063
A31VR1	1902-3082	9	1	DIODE-ZNR 4 64V 5% DO-35 PD= 4W	28480	1902-3082
A31W1	08340-60103	3	1	CABLE ASSEMBLY-A31	28480	08340-60103
A31W2	08340-60104	4	1	CABLE ASSEMBLY-A31	28480	08340-60104

A32 M/N Voltage-Controlled Oscillator Circuit Description

ASSEMBLY PURPOSE

The M/N voltage-controlled oscillator (VCO) is a varactor-tuned cavity oscillator consisting of a coaxial cavity resonator, a transistor circuit, and both a mechanical and an electrical tuning mechanism.

A32A2 VOLTAGE-CONTROLLED OSCILLATOR (BLOCK A)

A32A2 is an oscillator whose output frequency is dependent on the input voltage (TUN). The VCO output is applied to the buffer amplifier (block B).

A32A1 BUFFER AMPLIFIER (BLOCK B)

The buffer amplifier provides both isolation and gain for the VCO output signal. The buffer amplifier provides at least 0 dBm output over the 355 to 395 MHz range of the VCO.

A32 M/N Voltage-Controlled Oscillator Component-Level Troubleshooting

VOLTAGE CONTROLLED OSCILLATOR (VCO) (BLOCK A) BUFFER AMPLIFIER (BLOCK B)

The VCO output frequency with the tuning voltage set to -13.5 should be 380 MHz. Typical voltage levels for the VCO are as shown in Table A33-1.

Table A33-1. Typical VCO Voltage Levels

A32A1 Voltage Levels		
	Q2	Q1
Emitter	-10.8V	-8.3V
Base	-10.2V	-7.6V
Collector	0	0

A33 M/N Output Circuit Description

ASSEMBLY PURPOSE

The A33 M/N output assembly amplifies the output of the A32A2 M/N VCO in two different output paths. One path contains amplification and buffering (block B) to drive the mixer in the A31 M/N phase detector. The other path contains amplification and a divider (blocks C, D, and E) that provide 177-197 MHz to the A48 YO loop sampler.

Also included on the A33 assembly is the integrating loop amplifier, which generates the tuning voltage for the M/N VCO.

LOOP AMPLIFIER (BLOCK A)

VCO TUNE(+) AND VCO TUNE(-) (from the A31 M/N phase detector) are the two inputs to a differential-input integrating amplifier whose single-ended output signal is in the range of -5 to -35 volts. This signal passes through a 200 kHz low pass filter and tunes the A32A2 M/N VCO.

LO OUTPUT AMPLIFIER (BLOCK B)

The LO output amplifier functions as an isolation amplifier. Its forward gain is such that the output signal level is > 0dBm, and the reverse isolation is > 60dB. The output, 355-395 MHz OUT, passes through a 400 kHz low pass filter and is sent to the A31 M/N phase detector assembly.

LO AMPLIFIER (BLOCK C)

The LO amplifier amplifies the coupled-off portion of the A32A2 M/N VCO output signal to increase its level to 0 dBm.

DIVIDE-BY-2 (BLOCK D)

An EECL (HP ECL) divider generates the M/N output signal that is at one half the frequency of the M/N VCO (177-197 MHz).

M/N OUTPUT AMPLIFIER (BLOCK E)

The M/N output amplifier buffers and amplifies the output of the divide-by-2 (block D). The M/N OUT signal is the 177-197 Mhz input to the A48 YO loop sampler.

A33 M/N Output Circuit Component-Level Troubleshooting

INTRODUCTION

The VCO tune voltage from the A31 M/N phase detector is amplified and applied to the voltage controlled oscillator (VCO) by the LO output amplifier. The VCO output is amplified, divided by two, and applied to the A48 sampler for phase-locking the A44 YIG oscillator. A portion of the VCO output provides feed back to the A31 phase detector for phase locking the M/N loop.

To troubleshoot the A33 assembly, first press:

[SHIFT] [M1]
[CW] [3] [.] [7] [7] [GHz]

LOOP AMPLIFIER (BLOCK A)

You can measure the tune voltage from the loop amplifier can be measured at TP1, located on the cover of the the A33 assembly. The dc voltage at TP1, with the front panel settings indicated above, should be $-13.5V$. If an unlocked condition exists, the voltage is approximately $-0.5V$ or $-37.5V$. If the level is $-0.5V$, the probable cause is no VCO output to the A31 M/N phase detector. A level of $-37.5V$ indicates that the 20 MHz reference to the A31 phase detector is not present.

LO OUTPUT AMPLIFIER (BLOCK B)

Table A33-2. Typical LO Output Amplifier Voltage Levels

A32 Voltage Levels			
	Q5	Q2	Q1
Emitter	$-6.7V$	$-6.7V$	$-6.7V$
Base	$-6.2V$	$-6.2V$	$-6.2V$
Collector	$-0.5V$	0	0

LO AMPLIFIER (BLOCK C) M/N OUTPUT AMPLIFIER (BLOCK E)

Table A33-3. Typical LO Output Amplifier Voltage Levels

A32 Voltage Levels				
	Q6	Q7	Q3	Q4
Emitter	-6.7V	-3.1V	-4.5V	-5.2V
Base	-6.2V	-2.4V	-3.8V	-4.5V
Collector	-2.4V	0	0	0

Table A33-4. A33 M/N Output Pin I/O

Pin	Mnemonic	Levels	Source	Destination
1	VCO TUNE (+)		XA31P1-21	A
2	GND	0V	INSTRUMENT GROUND	*F
3	VCO TUNE (-)		XA31P1-6	A
4	GND	0V	INSTRUMENT GROUND	*F
5	-10V	-10V	XA34P2-8, 9	*F
6	GND	0V	INSTRUMENT GROUND	*F
7	-5.2V	-5.2V	XA34P2-12, 13	*F
8	GND	0V	INSTRUMENT GROUND	*F
9	GND	0V	INSTRUMENT GROUND	*F
10	GND	0V	INSTRUMENT GROUND	*F
11	GND	0V	XA34P2-6, 7	*F
12	-40V	-40V	INSTRUMENT GROUND	*F
13	GND	0V		*F
14	LMNE	TTL (LOW TRUE)	INSTRUMENT GROUND	D
15	GND	0V		*F

A single letter in the source or destination column refers to a function block on this assembly schematic.

An asterisk (*) denotes multiple sources or destinations; refer to the A34 Reference Loop - M/N Motherboard Schematic Diagram for a complete representation of signal sources and destinations.

A32 M/N VCO

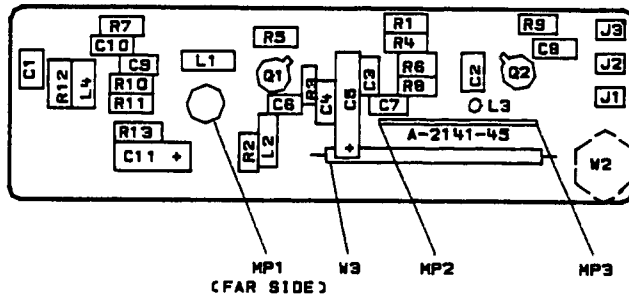

HP Part Number: 08340-60091

A33 M/N OUTPUT ASSEMBLY

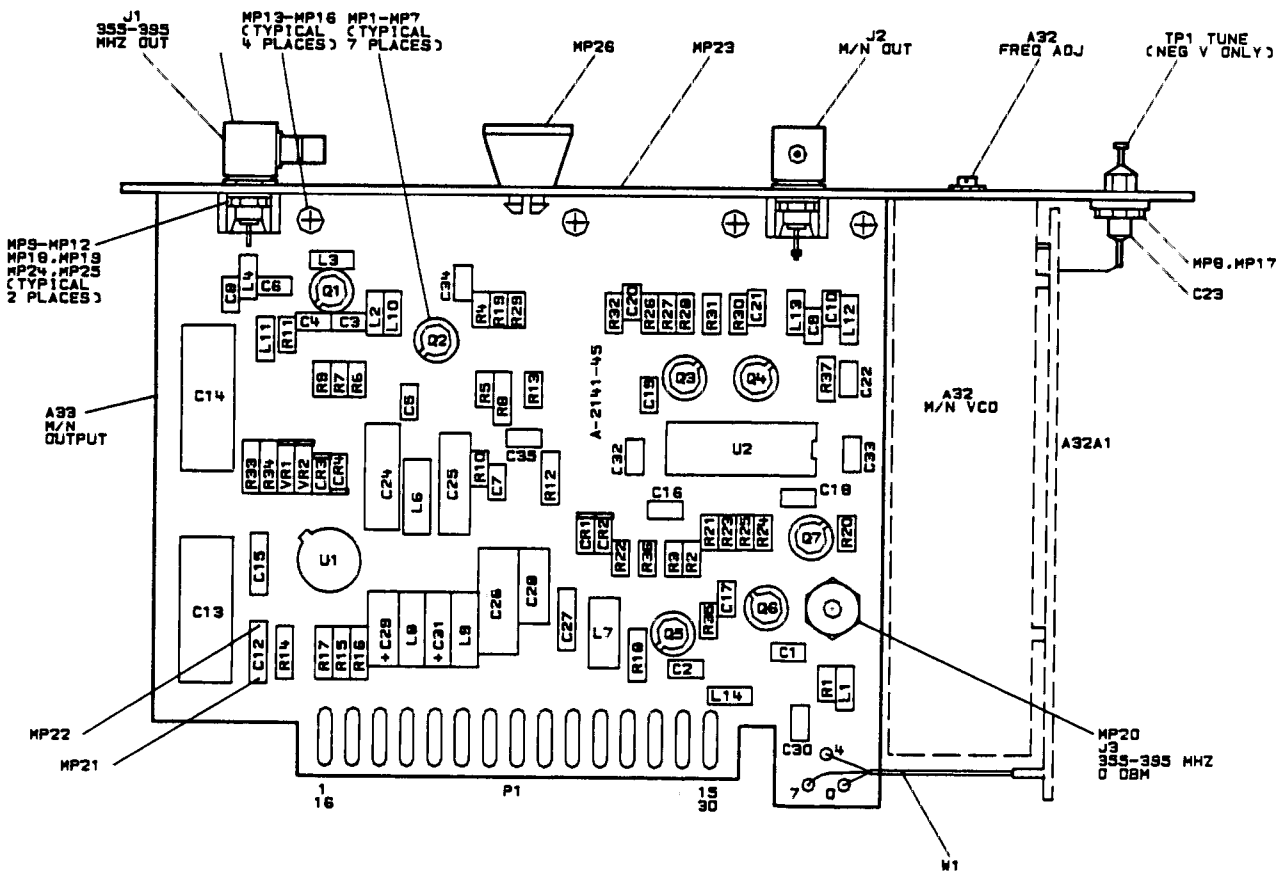

HP Part Number: 08340-60038

Figure A33-1. A32 M/N VCO and A33 M/N Output Assembly, Component Location Diagram

A33 M/N OUTPUT BOARD
08340-60039

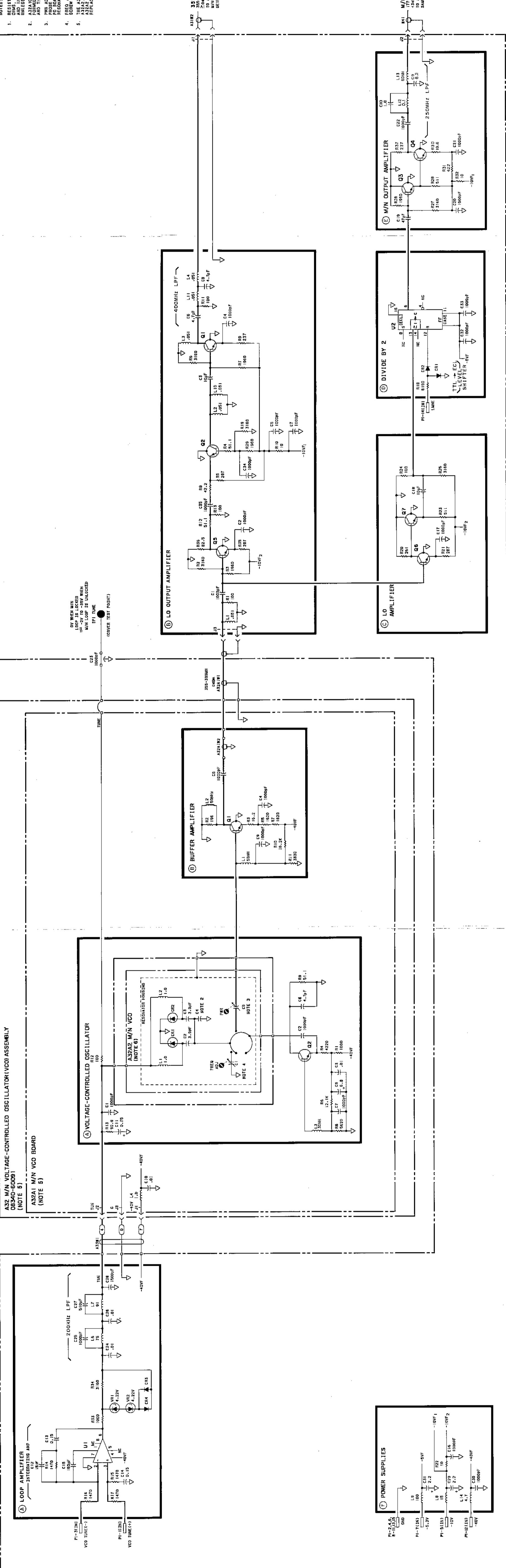

- NOTES:**
1. RESISTANCE VALUES SHOWN ARE IN OHMS, CAPACITANCE IN MICROFARADS, UNLESS OTHERWISE NOTED.
 2. A32A14 IS AN AIR DIELECTRIC CAPACITOR FORMED BY THE RESONATOR HOUSING AND THE RESONATOR CENTER CONDUCTOR.
 3. FREQ ADJUSTMENT THIS IS AN ADJUSTABLE POTENTIOMETER ON THE BOARD AND EXTENDING INTO THE RESONATOR HOUSING.
 4. FREQ ADJUSTMENT. THIS IS AN ADJUSTMENT SCREW LOCATED ON THE A33 BOARD COVER.
 5. A32A14, A32A15, A32A16, A32A17 AND A32A18 INDIVIDUAL COMPONENTS IN THE A32A1 ASSEMBLY ARE NOT SEPARATELY REPLACEABLE.

Figure A33-2. A32 M/N VCO and A33 M/N Output Assembly, Schematic Diagram
Reference Loop - M/N Loop A33-5/A33-6

A33 M/N Output Component-Level Troubleshooting

Table A33-5. A32 M/N VCO Replaceable Parts

Reference Designation	HP Part Number	C D	Qty	Description	Mfr Code	Mfr Part Number
A32	08340-60091	8	1	M/N VCO ASSEMBLY (08340-60091 INCLUDES A32A1 M/N VCO PC BD. AND A32A2 VCO)	28480	08340-60091
A32/A33	08340-60092	9	1	M/N-VCO/OUTPUT ASSEMBLY (INCLUDES A32 M/N VCO ASSY AND A33 M/N OUTPUT ASSY) A32A1 AND A32A2 NOT SEPARATELY REPLACEABLE	28480	08340-60092
A32A1C1	0160-3878	6	21	CAPACITOR-FXD 1000PF ± 20% 100VDC CER	28480	0160-3878
A32A1C2	0160-3878	6		CAPACITOR-FXD 1000PF ± 20% 100VDC CER	28480	0160-3878
A32A1C3	0160-3879	7	2	CAPACITOR-FXD 01UF ± 20% 100VDC CER	28480	0160-3879
A32A1C4	0160-3878	6		CAPACITOR-FXD 1000PF ± 20% 100VDC CER	28480	0160-3878
A32A1C5	0180-0118	1	1	CAPACITOR-FXD 6 8UF ± 10% 35VDC TA	56289	150D685X9035B2
A32A1C6	0160-3878	6		CAPACITOR-FXD 1000PF ± 20% 100VDC CER	28480	0160-3878
A32A1C7	0160-3878	6		CAPACITOR-FXD 1000PF ± 20% 100VDC CER	28480	0160-3878
A32A1C8	0160-3873	1	3	CAPACITOR-FXD 4 7PF ± .5PF 200VDC CER	28480	0160-3873
A32A1C9	0160-3878	6		CAPACITOR-FXD 1000PF ± 20% 100VDC CER	28480	0160-3878
A32A1C10	0160-3879	7		CAPACITOR-FXD 01UF ± 20% 100VDC CER	28480	0160-3879
A32A1C11	0180-2161	0	1	CAPACITOR-FXD 75UF ± 10% 50VDC TA	56289	150D754X9050A2
A32A1J1	1251-0600	0	3	CONNECTOR-SGL CONT PIN 1 14-MM-BSC-SZ SQ	28480	1251-0600
A32A1J2	1251-0600	0		CONNECTOR-SGL CONT PIN 1 14-MM-BSC-SZ SQ	28480	1251-0600
A32A1J3	1251-0600	0		CONNECTOR-SGL CONT PIN 1 14-MM-BSC-SZ SQ	28480	1251-0600
A32A1L1	9100-0346	0	2	INDUCTOR RF-CH-MLD 50NH 20% 105DX 26LG	28480	9100-0346
A32A1L2	9100-0346	0		INDUCTOR RF-CH-MLD 50NH 20% 105DX 26LG	28480	9100-0346
A32A1L3	86701-20051	7	1	INDUCTOR	28480	86701-20051
A32A1L4	9140-0158	6	3	INDUCTOR RF-CH-MLD 1UH 10% 105DX 26LG	28480	9140-0158
A32A1MP1	0590-0526	6	1	THREADED INSERT-NUT 4-40 065-IN-LG SST	28480	0590-0526
A32A1Q1	1854-0686	0	1	TRANSISTOR NPN SI TO-72 PD=200MW FT=4GHZ	28480	1854-0686
A32A1Q2	1854-0610	0	1	TRANSISTOR NPN SI TO-46 FT=800MHZ	28480	1854-0610
A32A1R1	0757-0280	3	2	RESISTOR 1K 1% 125W F TC=0±100	24546	C4-1/8-T0-1001-F
A32A1R2	0698-7219	6	1	RESISTOR 196 1% 05W F TC=0±100	24546	C3-1/8-T0-196R-F
A32A1R3	0698-7193	5	1	RESISTOR 16 2 1% 05W F TC=0±100	24546	C3-1/8-T0-16R2-F
A32A1R4	0698-3154	0	1	RESISTOR 4 22K 1% 125W F TC=0±100	24546	C4-1/8-T0-4221-F
A32A1R5	0757-0428	1	2	RESISTOR 1 62K 1% 125W F TC=0±100	24546	C4-1/8-T0-1621-F
A32A1R6	0698-7262	9	1	RESISTOR 12 1K 1% 05W F TC=0±100	24546	C3-1/8-T0-1212-F
A32A1R7	0757-0428	1		RESISTOR 1 62K 1% 125W F TC=0±100	24546	C4-1/8-T0-1621-F
A32A1R8	0698-7254	9	1	RESISTOR 5 62K 1% 05W F TC=0±100	24546	C3-1/8-T0-5621-F
A32A1R9	0698-7205	0	2	RESISTOR 51 1 1% 05W F TC=0±100	24546	C3-1/8-T0-51R1-F
A32A1R10	0698-7265	2	1	RESISTOR 16 2K 1% 05W F TC=0±100	24546	C3-1/8-T0-1622-F
A32A1R11	0698-7250	5	1	RESISTOR 3 83K 1% 05W F TC=0±100	24546	C3-1/8-T0-3831-F
A32A1R12	0757-0401	0	1	RESISTOR 100 1% 125W F TC=0±100	24546	C4-1/8-T0-101-F
A32A1R13	0757-0400	9	1	RESISTOR 90 9 1% 125W F TC=0±100	24546	C4-1/8-T0-90R9-F
A32A1W1	08340-60105	5	1	CABLE ASSEMBLY-COAX A32	28480	08340-60105
A32A1W2				NOT ASSIGNED		
A32A1W3	86701-20050	6	1	CABLE-JUMPER	28480	86701-20050
	1251-2313	6	2	CONNECTOR-SGL CONT SKT 04-IN-BSC-SZ RND	28480	1251-2313

A33 M/N Output Component-Level Troubleshooting

Table A33-6. A33 M/N Output Replaceable Parts

Reference Designation	HP Part Number	C D	Qty	Description	Mfr Code	Mfr Part Number
A33	08340-60038	3	1	M/N OUTPUT	28480	08340-60038
A33C1	0160-3878	6		CAPACITOR-FXD 1000PF ± 20% 100VDC CER	28480	0160-3878
A33C2	0160-3878	6		CAPACITOR-FXD 1000PF ± 20% 100VDC CER	28480	0160-3878
A33C3	0160-3874	2	3	CAPACITOR-FXD 10PF ± 5PF 200VDC CER	28480	0160-3874
A33C4	0160-3878	6		CAPACITOR-FXD 1000PF ± 20% 100VDC CER	28480	0160-3878
A33C5	0160-3878	6		CAPACITOR-FXD 1000PF ± 20% 100VDC CER	28480	0160-3878
A33C6	0160-3873	1		CAPACITOR-FXD 4 7PF ± 5PF 200VDC CER	28480	0160-3873
A33C7	0160-3878	6		CAPACITOR-FXD 1000PF ± 20% 100VDC CER	28480	0160-3878
A33C8	0160-3873	1		CAPACITOR-FXD 4 7PF ± 5PF 200VDC CER	28480	0160-3873
A33C9	0160-4491	1		CAPACITOR-FXD 8 2PF ± 5PF 200VDC CER	28480	0160-4491
A33C10	0160-4490	0	1	CAPACITOR-FXD 1 8PF ± 25PF 200VDC CER	28480	0160-4490
A33C11				NOT ASSIGNED		
A33C12	0160-2261	9	1	CAPACITOR-FXD 15PF ± 5% 500VDC CER 0 ± 30	28480	0160-2261
A33C13	0160-2290	4	2	CAPACITOR-FXD 15UF ± 10% 80VDC POLYE	28480	0160-2290
A33C14	0160-2290	4		CAPACITOR-FXD 15UF ± 10% 80VDC POLYE	28480	0160-2290
A33C15	0140-0196	3	1	CAPACITOR-FXD 100PF ± 5% 300VDC MICA	72136	DM15F151J0300WV1CR
A33C16	0160-3878	6		CAPACITOR-FXD 1000PF ± 20% 100VDC CER	28480	0160-3878
A33C17	0160-3878	6		CAPACITOR-FXD 1000PF ± 20% 100VDC CER	28480	0160-3878
A33C18	0160-3874	2		CAPACITOR-FXD 10PF ± 5PF 200VDC CER	28480	0160-3874
A33C19	0160-3876	4	1	CAPACITOR-FXD 47PF ± 20% 200VDC CER	28480	0160-3876
A33C20	0160-3878	6		CAPACITOR-FXD 1000PF ± 20% 100VDC CER	28480	0160-3878
A33C21	0160-3878	6		CAPACITOR-FXD 1000PF ± 20% 100VDC CER	28480	0160-3878
A33C22	0160-3878	6		CAPACITOR-FXD 1000PF ± 20% 100VDC CER	28480	0160-3878
A33C23	0160-4351	2	1	CAPACITOR-FDTHRU 1000PF 20% 200V CER	28480	0160-4351
A33C24	0160-0161	4	2	CAPACITOR-FXD 01UF ± 10% 200VDC POLYE	28480	0160-0161
A33C25	0160-0153	4	1	CAPACITOR-FXD 1000PF ± 10% 200VDC POLYE	28480	0160-0153
A33C26	0160-0161	4		CAPACITOR-FXD 01UF ± 10% 200VDC POLYE	28480	0160-0161
A33C27	0160-3534	1	1	CAPACITOR-FXD 510PF ± 5% 100VDC MICA	28480	0160-3534
A33C28	0160-0298	8	1	CAPACITOR-FXD 1500PF ± 10% 200VDC POLYE	28480	0160-0298
A33C29	0160-0197	8	2	CAPACITOR-FXD 2 2UF ± 10% 20VDC TA	56289	150D225X9020A2
A33C30	0160-3878	6		CAPACITOR-FXD 1000PF ± 20% 100VDC CER	28480	0160-3878
A33C31	0160-0197	8		CAPACITOR-FXD 2 2UF ± 10% 20VDC TA	56289	150D225X9020A2
A33C32	0160-3878	6		CAPACITOR-FXD 1000PF ± 20% 100VDC CER	28480	0160-3878
A33C33	0160-3878	6		CAPACITOR-FXD 1000PF ± 20% 100VDC CER	28480	0160-3878
A33C34	0160-3878	6		CAPACITOR-FXD 1000PF ± 20% 100VDC CER	28480	0160-3878
A33C35	0160-3878	6		CAPACITOR-FXD 1000PF ± 20% 100VDC CER	28480	0160-3878
A33CR1	1901-0040	1	4	DIODE-SWITCHING 30V 50MA 2NS DO-35	28480	1901-0040
A33CR2	1901-0040	1		DIODE-SWITCHING 30V 50MA 2NS DO-35	28480	1901-0040
A33CR3	1901-0040	1		DIODE-SWITCHING 30V 50MA 2NS DO-35	28480	1901-0040
A33CR4	1901-0040	1		DIODE-SWITCHING 30V 50MA 2NS DO-35	28480	1901-0040
A33J1	1250-0690	6	2	CONNECTOR-RF MALE SMB	28480	1250-0690
A33J2	1250-0690	6		CONNECTOR-RF MALE SMB	28480	1250-0690
A33J3	1250-1889	7	1	CONNECTOR-RF SMB M PC 50-OHM	28480	1250-1889
A33L1	9135-0073	3	8	INDUCTOR RF-CH-MLD 51NH 6% 102DX 26LG	28480	9135-0073
A33L2	9135-0073	3		INDUCTOR RF-CH-MLD 51NH 6% 102DX 26LG	28480	9135-0073
A33L3	9135-0073	3		INDUCTOR RF-CH-MLD 51NH 6% 102DX 26LG	28480	9135-0073
A33L4	9135-0073	3		INDUCTOR RF-CH-MLD 51NH 6% 102DX 26LG	28480	9135-0073
A33L5				NOT ASSIGNED		
A33L6	9100-1634	1	1	INDUCTOR RF-CH-MLD 75UH 5% 166DX 385LG	28480	9100-1634
A33L7	9100-1635	2	1	INDUCTOR RF-CH-MLD 91UH 5% 166DX 385LG	28480	9100-1635
A33L8	9100-1620	5	1	INDUCTOR RF-CH-MLD 15UH 10% 166DX 385LG	28480	9100-1620
A33L9	9140-0210	1	1	INDUCTOR RF-CH-MLD 100UH 5% 166DX 385LG	28480	9140-0210
A33L10	9135-0073	3		INDUCTOR RF-CH-MLD 51NH 6% 102DX 26LG	28480	9135-0073
A33L11	9135-0073	3		INDUCTOR RF-CH-MLD 51NH 6% 102DX 26LG	28480	9135-0073
A33L12	9135-0079	9		INDUCTOR RF-CH-MLD 100NH 5 5% 102DX 26LG	28480	9135-0079
A33L13	9135-0073	3		INDUCTOR RF-CH-MLD 51NH 6% 102DX 26LG	28480	9135-0073
A33L14	9140-0144	0	1	INDUCTOR RF-CH-MLD 4 7UH 10% 105DX 26LG	28480	9140-0144
A33MP1	1200-0172	4	7	INSULATOR-XSTR DAP-GL	28480	1200-0172
A33MP2	1200-0172	4		INSULATOR-XSTR DAP-GL	28480	1200-0172
A33MP3	1200-0172	4		INSULATOR-XSTR DAP-GL	28480	1200-0172
A33MP4	1200-0172	4		INSULATOR-XSTR DAP-GL	28480	1200-0172
A33MP5	1200-0172	4		INSULATOR-XSTR DAP-GL	28480	1200-0172
A33MP6	1200-0172	4		INSULATOR-XSTR DAP-GL	28480	1200-0172
A33MP7	1200-0172	4		INSULATOR-XSTR DAP-GL	28480	1200-0172
A33MP8	2190-0009	4	1	WASHER-LK INTL T NO 8 168-IN-ID	28480	2190-0009
A33MP9	2190-0124	4	4	WASHER-LK INTL T NO 10 195-IN-ID	28480	2190-0124
A33MP10	2190-0124	4		WASHER-LK INTL T NO 10 195-IN-ID	28480	2190-0124

A33 M/N Output Component-Level Troubleshooting

Table A33-6. A33 M/N Output Replaceable Parts

Reference Designation	HP Part Number	C D	Qty	Description	Mfr Code	Mfr Part Number
A33MP11	2190-0124	4		WASHER-LK INTL T NO. 10 195-IN-ID	28480	2190-0124
A33MP12	2190-0124	4		WASHER-LK INTL T NO. 10 195-IN-ID	28480	2190-0124
A33MP13	2200-0101	0	4	SCREW-MACH 4-40 188-IN-LG PAN-HD-POZI	00000	ORDER BY DESCRIPTION
A33MP14	2200-0101	0		SCREW-MACH 4-40 188-IN-LG PAN-HD-POZI	00000	ORDER BY DESCRIPTION
A33MP15	2200-0101	0		SCREW-MACH 4-40 188-IN-LG PAN-HD-POZI	00000	ORDER BY DESCRIPTION
A33MP16	2200-0101	0		SCREW-MACH 4-40 188-IN-LG PAN-HD-POZI	00000	ORDER BY DESCRIPTION
A33MP17	2580-0002	4	1	NUT-HEX-DBL-CHAM 8-32-THD 085-IN-THK	00000	ORDER BY DESCRIPTION
A33MP18	2950-0078	9	2	NUT-HEX-DBL-CHAM 10-32-THD 087-IN-THK	28480	2950-0078
A33MP19	2950-0078	9		NUT-HEX-DBL-CHAM 10-32-THD 087-IN-THK	28480	2950-0078
A33MP20	3050-0082	8	1	WASHER-FL NM NO. 4 116-IN-ID 188-IN-OD	28480	3050-0082
A33MP21	4330-0145	9	2	INSULATOR-BEAD GLASS	28480	4330-0145
A33MP22	4330-0145	9		INSULATOR-BEAD GLASS	28480	4330-0145
A33MP23	08340-20093	6	1	COVER-PC M/N OUTPUT	28480	08340-20093
A33MP24	85660-20068	4	2	GROUND LUG	28480	85660-20068
A33MP25	85660-20068	4		GROUND LUG	28480	85660-20068
A33MP26	86701-40001	9	1	EXTRACTOR-PC	28480	86701-40001
A33Q1	1854-0345	8	7	TRANSISTOR NPN 2N5179 SI TO-72 PD=200MW	04713	2N5179
A33Q2	1854-0345	8		TRANSISTOR NPN 2N5179 SI TO-72 PD=200MW	04713	2N5179
A33Q3	1854-0345	8		TRANSISTOR NPN 2N5179 SI TO-72 PD=200MW	04713	2N5179
A33Q4	1854-0345	8		TRANSISTOR NPN 2N5179 SI TO-72 PD=200MW	04713	2N5179
A33Q5	1854-0345	8		TRANSISTOR NPN 2N5179 SI TO-72 PD=200MW	04713	2N5179
A33Q6	1854-0345	8		TRANSISTOR NPN 2N5179 SI TO-72 PD=200MW	04713	2N5179
A33Q7	1854-0345	8		TRANSISTOR NPN 2N5179 SI TO-72 PD=200MW	04713	2N5179
A33R1	0698-7212	9	4	RESISTOR 100 1% 05W F TC=0±100	24546	C3-1/8-TO-100R-F
A33R2	0698-7248	1	5	RESISTOR 3 16K 1% 05W F TC=0±100	24546	C3-1/8-TO-3161-F
A33R3	0698-7243	6	4	RESISTOR 1 96K 1% 05W F TC=0±100	24546	C3-1/8-TO-1961-F
A33R4	0698-7205	0		RESISTOR 51 1 1% 05W F TC=0±100	24546	C3-1/8-TO-51R1-F
A33R5	0698-7223	2	3	RESISTOR 287 1% 05W F TC=0±100	24546	C3-1/8-TO-287R-F
A33R6	0698-7248	1		RESISTOR 3 16K 1% 05W F TC=0±100	24546	C3-1/8-TO-3161-F
A33R7	0698-7243	6		RESISTOR 1 96K 1% 05W F TC=0±100	24546	C3-1/8-TO-1961-F
A33R8	0757-0316	6	1	RESISTOR 42 2 1% 125W F TC=0±100	24546	C4-1/8-TO-42R2-F
A33R9	0698-7221	0	1	RESISTOR 237 1% 05W F TC=0±100	24546	C3-1/8-TO-237R-F
A33R10	0698-7188	8	3	RESISTOR 10 1% 05W F TC=0±100	24546	C3-1/8-TO-10R-F
A33R11	0698-7212	9		RESISTOR 100 1% 05W F TC=0±100	24546	C3-1/8-TO-100R-F
A33R12	0757-0394	0	1	RESISTOR 51 1 1% 125W F TC=0±100	24546	C4-1/8-TO-51R1-F
A33R13	0698-7212	9		RESISTOR 100 1% 05W F TC=0±100	24546	C3-1/8-TO-100R-F
A33R14	0757-1094	9	4	RESISTOR 1 47K 1% 125W F TC=0±100	24546	C4-1/8-TO-1471-F
A33R15	0757-1094	9		RESISTOR 1 47K 1% 125W F TC=0±100	24546	C4-1/8-TO-1471-F
A33R16	0757-1094	9		RESISTOR 1 47K 1% 125W F TC=0±100	24546	C4-1/8-TO-1471-F
A33R17	0757-1094	9		RESISTOR 1 47K 1% 125W F TC=0±100	24546	C4-1/8-TO-1471-F
A33R18	0757-0290	5	1	RESISTOR 6 19K 1% 125W F TC=0±100	19701	MFAC1/8-TO-6191-F
A33R19	0698-7248	1		RESISTOR 3 16K 1% 05W F TC=0±100	24546	C3-1/8-TO-3161-F
A33R20	0698-7222	1	1	RESISTOR 281 1% 05W F TC=0±100	24546	C3-1/8-TO-281R-F
A33R21	0698-7223	2		RESISTOR 287 1% 05W F TC=0±100	24546	C3-1/8-TO-287R-F
A33R22	0698-7188	8		RESISTOR 10 1% 05W F TC=0±100	24546	C3-1/8-TO-10R-F
A33R23	0698-7229	8	2	RESISTOR 511 1% 05W F TC=0±100	24546	C3-1/8-TO-511R-F
A33R24	0698-7212	9		RESISTOR 100 1% 05W F TC=0±100	24546	C3-1/8-TO-100R-F
A33R25	0698-7248	1		RESISTOR 3 16K 1% 05W F TC=0±100	24546	C3-1/8-TO-3161-F
A33R26	0698-7243	6		RESISTOR 1 96K 1% 05W F TC=0±100	24546	C3-1/8-TO-1961-F
A33R27	0698-7248	1		RESISTOR 3 16K 1% 05W F TC=0±100	24546	C3-1/8-TO-3161-F
A33R28	0698-7229	8		RESISTOR 511 1% 05W F TC=0±100	24546	C3-1/8-TO-511R-F
A33R29	0698-7243	6		RESISTOR 1 96K 1% 05W F TC=0±100	24546	C3-1/8-TO-1961-F
A33R30	0698-7195	7	1	RESISTOR 19 6 1% 05W F TC=0±100	24546	C3-1/8-TO-19R6-F
A33R31	0698-7227	6	1	RESISTOR 422 1% 05W F TC=0±100	24546	C3-1/8-TO-422R-F
A33R32	0698-7188	8		RESISTOR 10 1% 05W F TC=0±100	24546	C3-1/8-TO-10R-F
A33R33	0757-0280	3		RESISTOR 1K 1% 125W F TC=0±100	24546	C4-1/8-TO-1001-F
A33R34	0757-0279	0	1	RESISTOR 3 16K 1% 125W F TC=0±100	24546	C4-1/8-TO-3161-F
A33R35	0698-7223	2		RESISTOR 287 1% 05W F TC=0±100	24546	C3-1/8-TO-287R-F
A33R36	0698-7210	7	1	RESISTOR 82 5 1% 05W F TC=0±100	24546	C3-1/8-TO-82R5-F
A33R37	0698-3442	9	1	RESISTOR 237 1% 125W F TC=0±100	24546	C3-1/8-TO-237R-F
A33U1	1826-0059	2	1	IC OP AMP GP TO-99 PKG	01295	LM201AL
A33U2	1820-2642	1	1	IC CNTR ECL BIN DUAL	28480	1820-2642
A33VR1	1902-3070	5	2	DIODE-ZNR 4 22V 5% DO-35 PD= 4W	28480	1902-3070
A33VR2	1902-3070	5		DIODE-ZNR 4 22V 5% DO-35 PD= 4W	28480	1902-3070
A33W1	08340-60123	7	1	JUMPER WIRE ASSEMBLY	28480	08340-60123

A34 Reference – M/N Motherboard Component-Level Troubleshooting

Table A34-1. A34 Reference – M/N Motherboard P1 Pin I/O

Pin	Mnemonic	Levels	Source	Destination
1	M5	TTL (HIGH TRUE)	XA59P1-31	XA31P1-15
2	LMNE	TTL (LOW TRUE)	XA59P1-86	*
3	M3	TTL (HIGH TRUE)	XA59P1-32	XA31P1-14
4	M4	TTL (HIGH TRUE)	XA59P1-87	XA31P1-29
5	M1	TTL (HIGH TRUE)	XA59P1-33	XA31P1-13
6	M2	TTL (HIGH TRUE)	XA59P1-88	XA31P1-28
7				
8	HULM	TTL (HIGH TRUE)	XA31P1-26	XA31P1-26
9				
10	N6	TTL	XA59P1-101	XA31P1-24
11	N5	TTL	XA59P1-46	XA31P1-9
12	N4	TTL	XA59P1-102	XA31P1-25
13	N3	TTL	XA59P1-47	XA31P1-10
14	N2	TTL	XA59P1-103	XA31P1-23
15	N1	TTL	XA59P1-48	XA31P1-8

Table A34-2. A34 Reference – M/N Motherboard P2 Pin I/O

Pin	Mnemonic	Levels	Source	Destination
1				
2	+20V	+20V	XA52P1-16, 40	*
3	+20V	+20V	XA52P1-16, 40	*
4	+5.2V	+5.2V	XA52P1-17, 18, 41, 42	*
5	+5.2V	+5.2V	XA52P1-17, 18, 41, 42	*
6	-40V	-40V	XA53P1-11, 30	*
7	-40V	-40V	XA53P1-11, 30	*
8	-10V	-10V	XA53P1-12, 13, 31, 32	*
9	-10V	-10V	XA53P1-12, 13, 31, 32	*
10	GND	0V	A62 STAR GND	*
11	GND	0V	A62 STAR GND	*
12	-5.2V	-5.2V	XA53P1-18, 36	*
13	-5.2V	-5.2V	XA53P1-18, 36	*
14	HULR	TTL (HIGH TRUE)	XA29P1-7	XA29P1-7
15				

A single letter in the source or destination column refers to a function block on this assembly schematic.

An asterisk (*) denotes multiple sources or destinations: refer to the A34 Reference Loop – M/N Motherboard Schematic Diagram for a complete representation of signal sources and destinations.

**A34 M/N REFERENCE MOTHERBOARD
(Bottom View)**

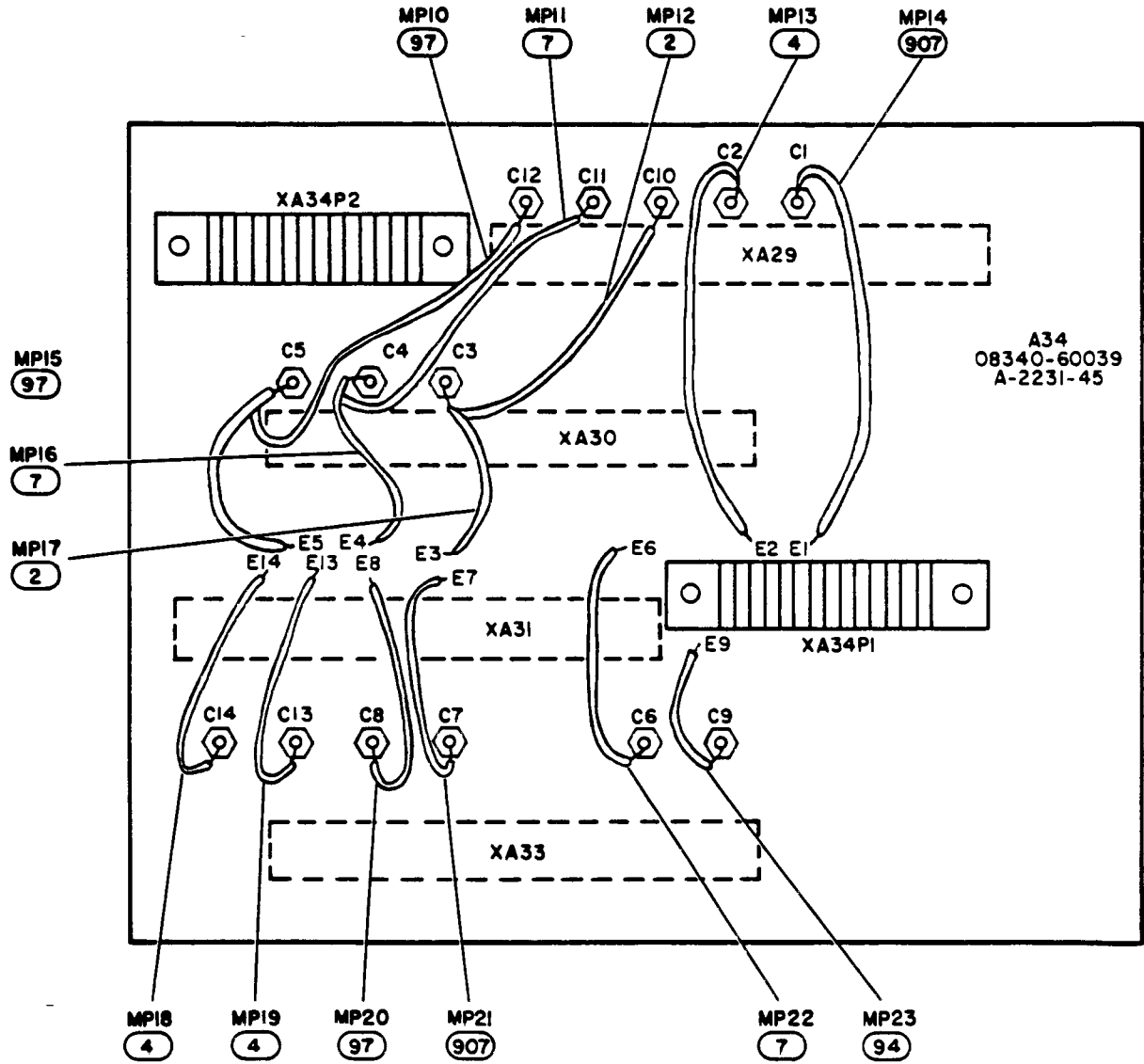

HP Part Number: 08340-60039

Figure A34-1. A34 Reference - M/N Motherboard Component Location Diagram (1 of 2)

**A34 M/N REFERENCE MOTHERBOARD
(Top View)**

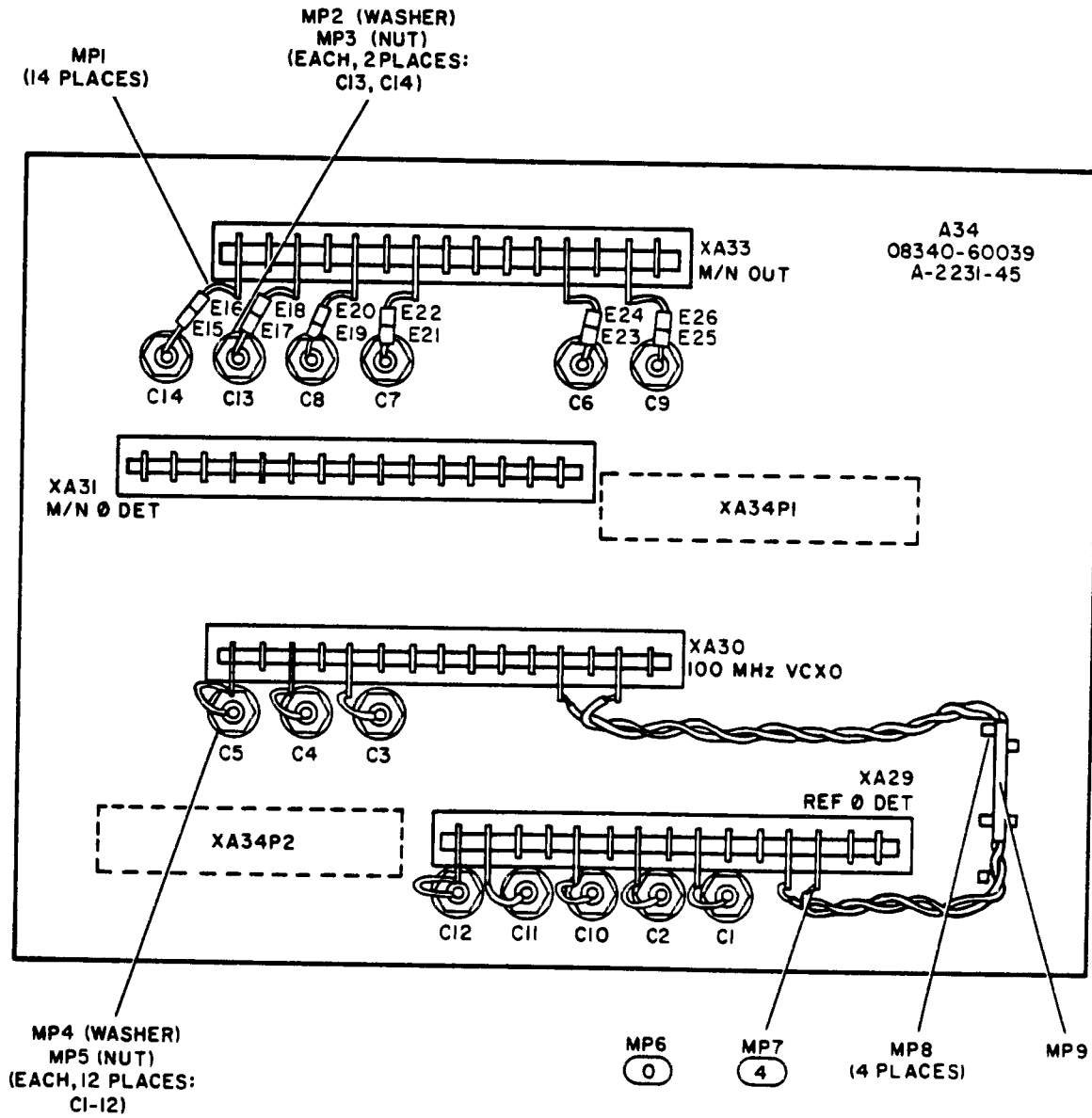

Figure A34-1. A34 Reference - M/N Motherboard Component Location Diagram (2 of 2)

A34 M/N REFERENCE MOTHERBOARD
08340-60039

NOTES:

- RESISTANCE VALUES SHOWN ARE IN OHMS, CAPACITANCE IN MICROFARADS, UNLESS OTHERWISE NOTED.

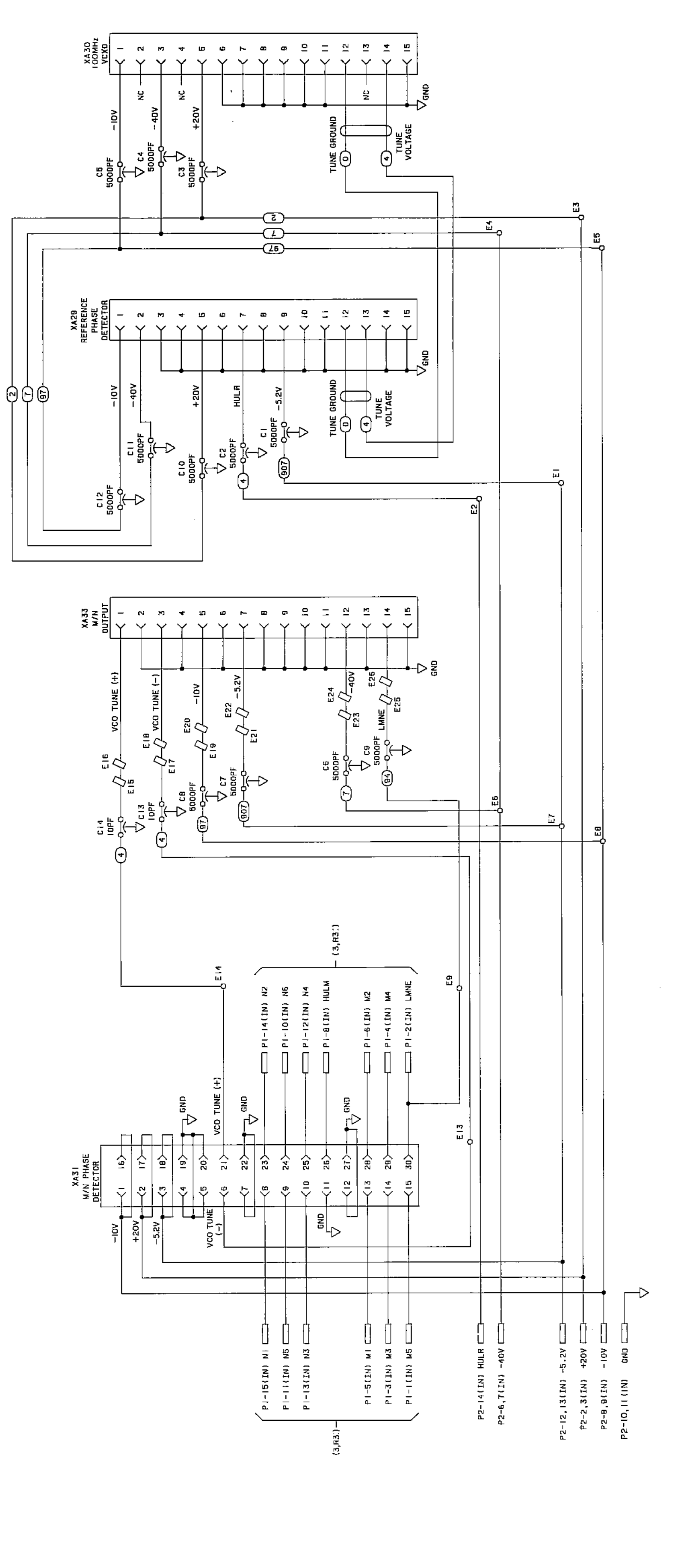

Figure A34-2. A34 Reference Loop - M/N Loop Motherboard, Schematic Diagram
Reference Loop - M/N Loop A34-5/A34-6

A34 Reference - M/N Motherboard Component-Level Troubleshooting

Table A34-3. A34 Reference Loop - M/N Loop Motherboard Replaceable Parts

Reference Designation	HP Part Number	C	D	Qty	Description	Mfr Code	Mfr Part Number
A34	08340-60039	4		1	REFERENCE M/N MOTHERBOARD	28480	08340-60039
A34C1	0160-2437	1		12	CAPACITOR-FDTHRU 5000PF +80 -20% 200V	28480	0160-2437
A34C2	0160-2437	1			CAPACITOR-FDTHRU 5000PF +80 -20% 200V	28480	0160-2437
A34C3	0160-2437	1			CAPACITOR-FDTHRU 5000PF +80 -20% 200V	28480	0160-2437
A34C4	0160-2437	1			CAPACITOR-FDTHRU 5000PF +80 -20% 200V	28480	0160-2437
A34C5	0160-2437	1			CAPACITOR-FDTHRU 5000PF +80 -20% 200V	28480	0160-2437
A34C6	0160-2437	1			CAPACITOR-FDTHRU 5000PF +80 -20% 200V	28480	0160-2437
A34C7	0160-2437	1			CAPACITOR-FDTHRU 5000PF +80 -20% 200V	28480	0160-2437
A34C8	0160-2437	1			CAPACITOR-FDTHRU 5000PF +80 -20% 200V	28480	0160-2437
A34C9	0160-2437	1			CAPACITOR-FDTHRU 5000PF +80 -20% 200V	28480	0160-2437
A34C10	0160-2437	1			CAPACITOR-FDTHRU 5000PF +80 -20% 200V	28480	0160-2437
A34C11	0160-2437	1			CAPACITOR-FDTHRU 5000PF +80 -20% 200V	28480	0160-2437
A34C12	0160-2437	1			CAPACITOR-FDTHRU 5000PF +80 -20% 200V	28480	0160-2437
A34C13	0160-4083	7		2	CAPACITOR-FDTHRU 10PF 10% 200V CER	28480	0160-4083
A34C14	0160-4083	7			CAPACITOR-FDTHRU 10PF 10% 200V CER	28480	0160-4083
A34E1-9	9170-0029	3		12	CORE-SHIELDING BEAD	28480	9170-0029
A34E10-12					NOT ASSIGNED		
A34E13-26	9170-0029	3			CORE-SHIELDING BEAD	28480	9170-0029
A34MP1	8150-0014	3		1	WIRE-24 AWG 1 X 24	28480	8150-0014
A34MP2	2190-0007	2		2	WASHER-LK INTL T NO 6 141-IN-ID	28480	2190-0007
A34MP3	2420-0003	7		2	NUT-HEX-DBL-CHAM 6-32-THD 094-IN-THK	00000	ORDER BY DESCRIPTION
A34MP4	2190-0843	4		12	WASHER-LK INTL T NO 8 165-IN-ID	28480	2190-0843
A34MP5	2580-0002	4		12	NUT-HEX-DBL-CHAM 8-32-THD 085-IN-THK	00000	ORDER BY DESCRIPTION
A34MP6	8150-0447	6		1	WIRE-24 AWG 300V 0	28480	8150-0447
A34MP7	85660-00037	5		1	INSULATOR-15 PIN (FOR XA33)	28480	85660-00037
A34MP8	1251-0600	0		1	CONNECTOR-SGL CONT PIN 1 14-MM-BSC-SZ SQ	28480	1251-0600
A34MP9	0890-0983	5			TUBING-HEAT SINK 125ID	28480	0890-0983
A34MP10	8150-0464	7		3	WIRE-24 AWG 300V 97	28480	8150-0464
A34MP11	8150-0454	5		3	WIRE-24 AWG 300V 7	28480	8150-0454
A34MP12	8150-0449	8		2	WIRE-24 AWG 300V 2	28480	8150-0449
A34MP13	8150-0451	2		3	WIRE-24 AWG 300V 4	28480	8150-0451
A34MP14	8150-0472	7		2	WIRE-24 AWG 300V 907	28480	8150-0472
A34MP15	8150-0464	7			WIRE-24 AWG 300V 97	28480	8150-0464
A34MP16	8150-0454	5			WIRE-24 AWG 300V 7	28480	8150-0454
A34MP17	8150-0449	8			WIRE-24 AWG 300V 2	28480	8150-0449
A34MP18	8150-0451	2			WIRE-24 AWG 300V 4	28480	8150-0451
A34MP19	8150-0451	2			WIRE-24 AWG 300V 4	28480	8150-0451
A34MP20	8150-0464	7			WIRE-24 AWG 300V 97	28480	8150-0464
A34MP21	8150-0472	7			WIRE-24 AWG 300V 907	28480	8150-0472
A34MP22	8150-0454	5			WIRE-24 AWG 300V 7	28480	8150-0454
A34MP23	8150-0461	4		1	WIRE-24 AWG 300V 94	28480	8150-0461
A34XA29	1251-4423	3		1	CONNECTOR-PC EDGE 15-CONT/ROW 1-ROW	28480	1251-4423
	85660-00051	3		1	INSULATOR-15 PIN (FOR XA29)	28480	85660-00051
A34XA30	1251-4174	1		1	CONNECTOR-PC EDGE 15-CONT/ROW 1-ROW	28480	1251-4174
	85660-00050	2		1	INSULATOR-15 PIN (FOR XA30)	28480	85660-00050
A34XA31	1251-2035	9		1	CONNECTOR-PC EDGE 15-CONT/ROW 2-ROWS	28480	1251-2035
A34XA32					NOT ASSIGNED		
A34XA33	1251-5020	8		1	CONNECTOR-PC 15 IR	28480	1251-5020
A34XA34A	5060-0112	8		1	CONNECTOR-15 CONTACT DIP	28480	5060-0112
A34XA34B	5060-0112	8			CONNECTOR-15 CONTACT DIP	28480	5060-0112

**REFERENCE OSCILLATOR
A51 10 MHz**

HP Part Number: 08340-60183

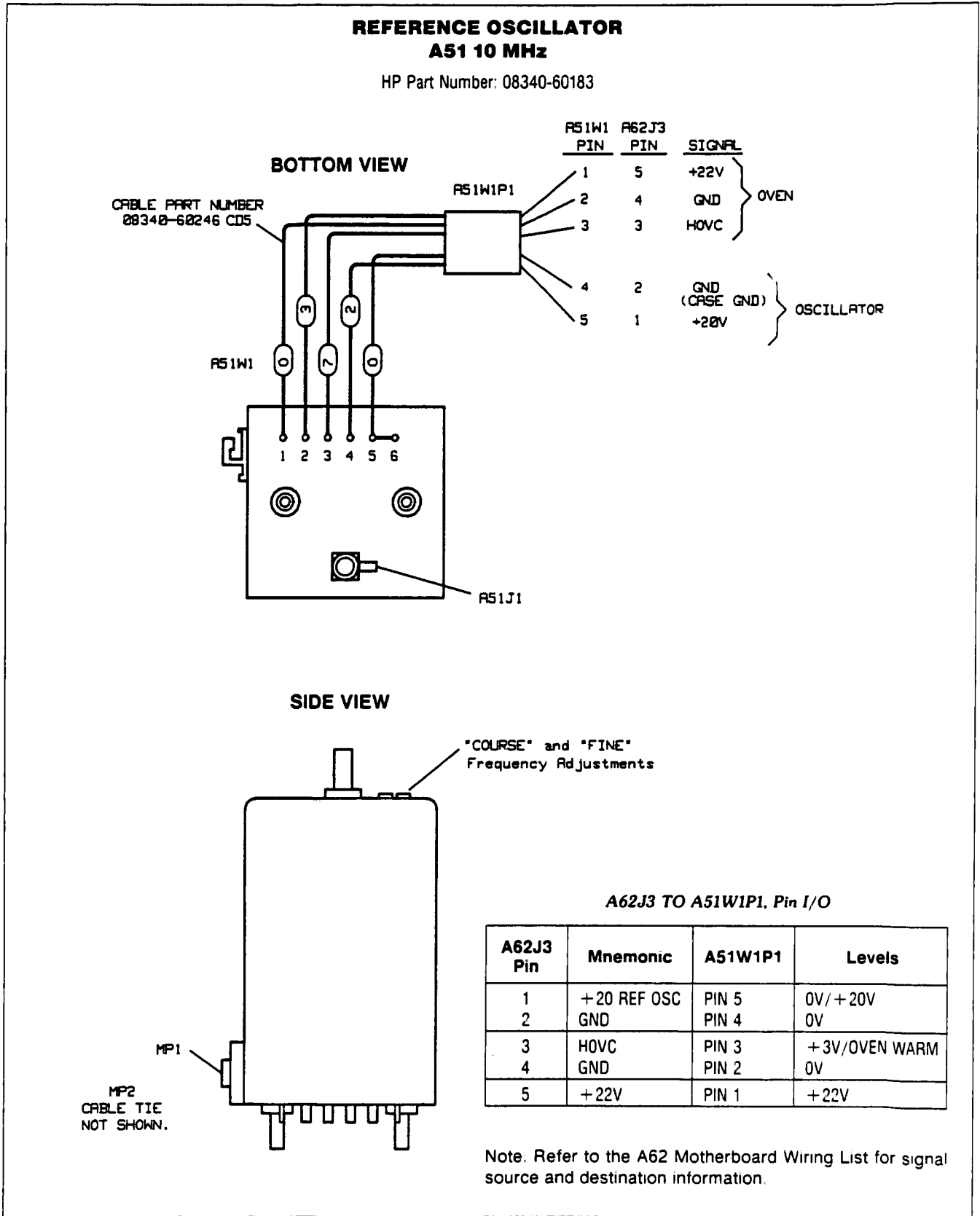

Figure A51-1. A51 10 MHz Reference Oscillator, Output Wiring Diagram, Part Number

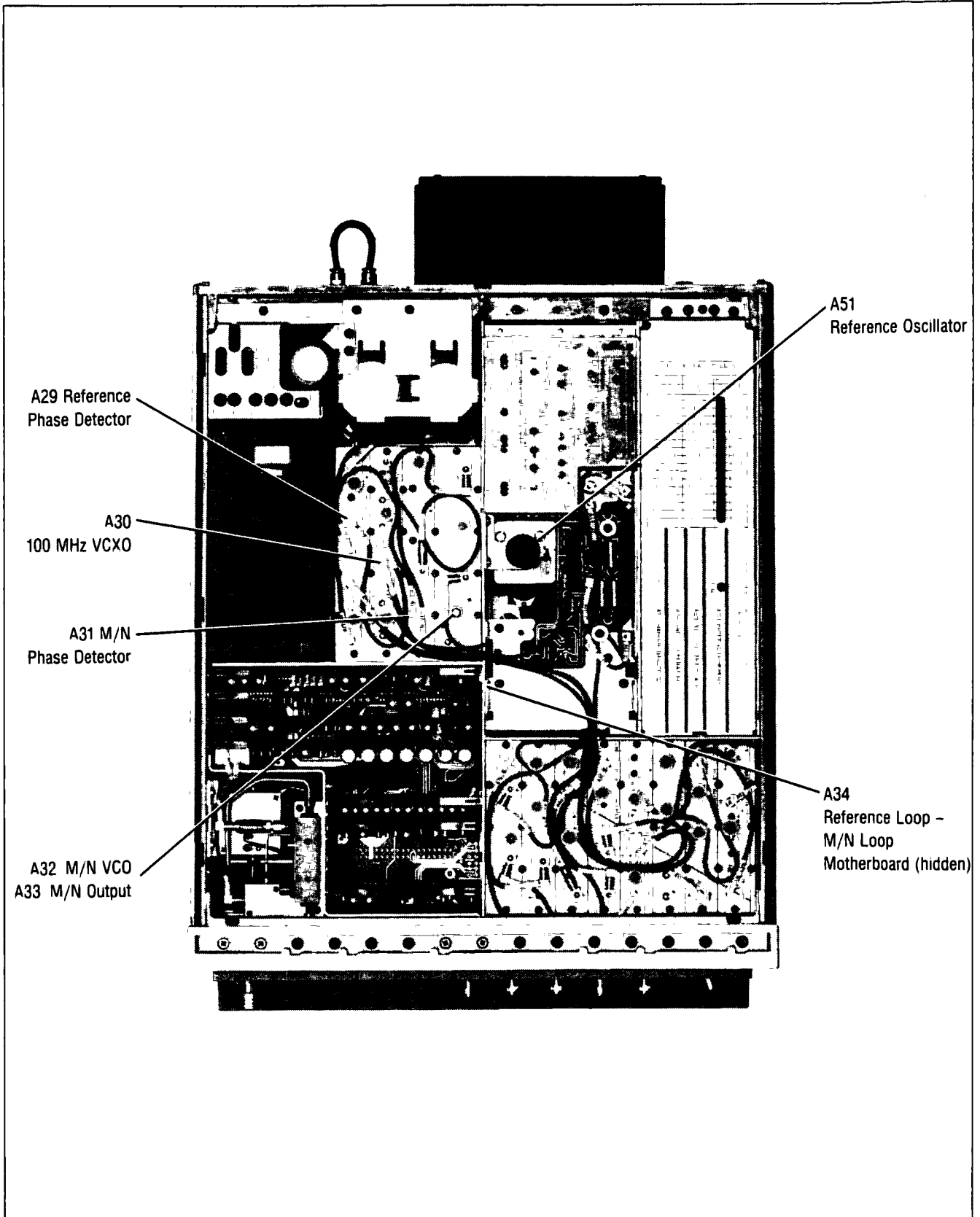

Figure A51-2. Reference Loop - M/N Loop Major Assemblies Location

20/30 Loops Component-Level Service

CONTENTS

A36 PHASE LOCK LOOP 1 VOLTAGE-CONTROLLED OSCILLATOR

CIRCUIT DESCRIPTION	A36-1
Assembly Purpose	A36-1
Loop Amplifier (Block A)	A36-1
Gain Switch (Block B)	A36-2
200 to 300 MHz VCO (Block C), Output Amplifier (Block D)	A36-2
Divide-by-10 (Block F)	A36-3
Output Switch (Block E)	A36-3
A36 PLL1 VCO Pin I/O	A36-4
A36 PLL1 VCO Component Location Diagram	A36-6
A36 PLL1 VCO Schematic Diagram	A36-7
A36 PLL1 VCO Replaceable Parts	A36-9

A37 PHASE LOCK LOOP 1 DIVIDER

CIRCUIT DESCRIPTION	A37-1
Assembly Purpose	A37-1
Divide-by-2 (Block A)	A37-1
Input Latch (Block B)	A37-2
Divide-by-N (Block C)	A37-2
Fractional Divider (Block D)	A37-3
Phase/Frequency Detector (Block E)	A37-6
Reference Divide-by-2 (Block F)	A37-6
Phase Lock Indicator (Block G)	A37-6
A37 PLL1 Divider Pin I/O	A37-7
A37 PLL1 Divider Component Location Diagram	A37-8
A37 PLL1 Divider Schematic Diagram	A37-9
A37 PLL1 Divider Replaceable Parts	A37-11

A38 PHASE LOCK LOOP 1 IF

CIRCUIT DESCRIPTION	A38-1
Assembly Purpose	A38-1
LO Amplifier (Block A)	A38-1
Mixer (Block B)	A38-1
IF Input Amplifier (Block C)	A38-1
IF Output Amplifier (Block D)	A38-1
140 MHz Low-Pass Filter (Block E)	A38-1
A38 PLL1 IF Pin I/O	A38-2
A38 PLL1 IF Component Location Diagram	A38-4
A38 PLL1 IF Schematic Diagram	A38-5
A38 PLL1 IF Replaceable Parts	A38-7

CONTENTS (Cont'd)

A39 PHASE LOCK LOOP 3 UPCONVERTER

CIRCUIT DESCRIPTION	A39-1
Assembly Purpose	A39-1
Frequency Multiplier ($\times 1.6$) (Block A)	A39-1
Mixer (Block B)	A39-2
IF Amplifier (Block C)	A39-2
160 to 166 MHz VCO (Voltage Controlled Oscillator) (Block D)	A39-2
Phase/Frequency Detector (Block E)	A39-2
Loop Amplifier (Block F)	A39-3
Phase Lock Indicator (Block G)	A39-4
A39 PLL3 Upconverter Pin I/O	A39-5
A39 PLL3 Upconverter Component Location Diagram	A39-6
A39 PLL3 Upconverter Schematic Diagram	A39-7
A39 PLL3 Upconverter Replaceable Parts	A39-9

A40 PHASE LOCK LOOP 2 VCO

CIRCUIT DESCRIPTION	A40-1
Assembly Purpose	A40-1
Bias Network/50 kHz Low Pass Filter (Block A)	A40-1
VCO (Block B)	A40-2
75-150 MHz Output Buffer (Block C)	A40-2
Frequency Dividers (Block D)	A40-3
Small Delta F Switch (Block E)	A40-3
0.1 to 5 MHz Delta F Switch (Block F)	A40-3
A40 PLL2 VCO Pin I/O	A40-4
A40 PLL2 VCO Component Location Diagram	A40-6
A40 PLL2 VCO Schematic Diagram	A40-7
A40 PLL2 VCO Replaceable Parts	A40-9

A41 PHASE LOCK LOOP 2 PHASE DETECTOR

CIRCUIT DESCRIPTION	A41-1
Assembly Purpose	A41-1
Phase-Frequency Detector (Block A)	A41-1
Digital Integrator (Block B)	A41-2
Analog Integrator - Sample and Hold (Block C)	A41-2
Output Amplifier (Block D)	A41-2
Unlock Indicator (Block E)	A41-3
A41 PLL2 Phase Detector Pin I/O	A41-4
A41 PLL2 Phase Detector Component Location Diagram	A41-6
A41 PLL2 Phase Detector Schematic Diagram	A41-7
A41 PLL2 Phase Detector Replaceable Parts	A41-9

CONTENTS (Cont'd)

A42 PHASE LOCK LOOP 2 DIVIDER

CIRCUIT DESCRIPTION	A42-1
Assembly Purpose	A42-1
Latches (Block A)	A42-1
Reference Divider (Block D)	A42-1
Fractional Divide Circuitry	A42-2
Prescaler (Block E)	A42-2
Direct Divide (Block B)	A42-2
Integer Counter (Block F)	A42-3
Fractional Counter (Block C)	A42-3
Synchronizer (Block G)	A42-3
A42 PLL2 Divider Pin I/O	A42-6
A42 PLL2 Divider Component Location Diagram	A42-8
A42 PLL2 Divider Schematic Diagram	A42-9
A42 PLL2 Divider Replaceable Parts	A42-11

A43 PHASE LOCK LOOP 2 DISCRIMINATOR

CIRCUIT DESCRIPTION	A43-1
Assembly Purpose	A43-1
Pulse Generator (Block A)	A43-2
Current Source (Block B)	A43-2
-7V Supply (Block C)	A43-3
Pretune (Block D)	A43-3
Delta F Sweep Attenuator (Block E)	A43-3
Summing Amplifier (Block F)	A43-4
Output Current Source (Block G)	A43-4
A43 PLL2 Discriminator Pin I/O	A43-7
A43 PLL2 Discriminator Component Location Diagram	A43-8
A43 PLL2 Discriminator Schematic Diagram	A43-9
A43 PLL2 Discriminator Replaceable Parts	A43-11
20/30 Loop Major Assemblies Diagram	A43-14

A36 Phase Lock Loop 1 Voltage-Controlled Oscillator Circuit Description

ASSEMBLY PURPOSE

The phase lock loop 1 (PLL1) voltage-controlled oscillator (VCO) assembly is the final stage of the 20-30 Loops. The output of this assembly goes directly to the YO loop, where it phase-locks the instrument's main RF oscillator. This assembly switches between two different phase-lock loop references. These two reference signals differ in resolution, and are selected for different output frequency sweep-widths.

Narrow Sweep Mode (<0.1 MHz)

A36 contains the loop amplifier and voltage-controlled oscillator for the PLL1 phase lock loop. The oscillator drives a counter that divides the frequency by ten. The counter output goes through a switch and a filter to the 20-30 output.

Wide Sweep Mode (Between >0.1 MHz and ≤ 5 MHz)

When instrument sweep width is between >0.1 MHz and ≤ 5 MHz, the A36 assembly passes the 15-30 MHz signal from the PLL2 VCO (A36W1) directly through to the output (W39). In this mode the voltage-controlled oscillator is turned off to prevent spurious responses.

LOOP AMPLIFIER (BLOCK A)

A diagram of the equivalent circuit of the loop amplifier is shown in Figure A36-1. The loop amplifier functions as a differential integrator. The low-noise differential pair (Q9 and Q10) and operational amplifier U6A provide gain. A resistor and a capacitor across the input provide compensation for high open-loop gain. There is no DC feedback path in this circuit, so it has extremely high gain for low frequency signals.

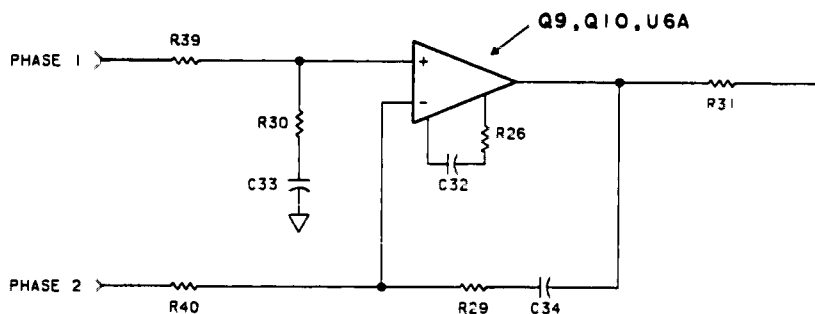

Figure A36-1. Loop Amplifier Equivalent Circuit

The output of the differential integrator goes through the programmable AC voltage divider shown in the gain switch (block b), and then through the 40kHz low pass filter in block A. The filter rejects a 50kHz spurious signal which is generated by the fractional divider in the PLL1 divider.

GAIN SWITCH (BLOCK B)

The latch outputs are level translated by four operational amplifiers and drive four FET switches. Activating combinations of FET switches places a programmable resistance in parallel with circuitry in the loop amplifier (block A) and changes the amount of signal attenuation. As the A37 assembly's digital divider changes numbers, PLL1's loop gain directly follows it. Increasing the amount of gain in the loop amplifier provides a constant loop bandwidth of 5 kHz.

200 TO 300 MHz VCO (BLOCK C) OUTPUT AMPLIFIER (BLOCK D)

Q11 and surrounding components form a grounded-base resonator circuit. The output is actually at the front of this stage, before varactor diodes CR3 and CR4. Tuning the varactor between 4 and 16 volts causes the oscillator to output frequencies of 200 to 300 MHz. This output signal is coupled through R42 and C12 and is applied to the emitter of Q5 (a common-base buffer amplifier). See Figure A36-2 for a simplified diagram of block A.

The VCO is turned off in sweeps >0.1 MHz and <5 MHz by forward biasing varactor diodes CR3 and CR4. A low input on SW1 (from block E) causes CR2 (in block A) to conduct and pull the base of Q2 (in block A) to about 0.7V. This sets the clamp voltage at the cathode of CR7 to about -0.7 volts, which biases the diodes on and disables the VCO.

The output of block C is amplified by block D and sent to:

- Block F, divide by 10
- The A38 PLL1 IF assembly.

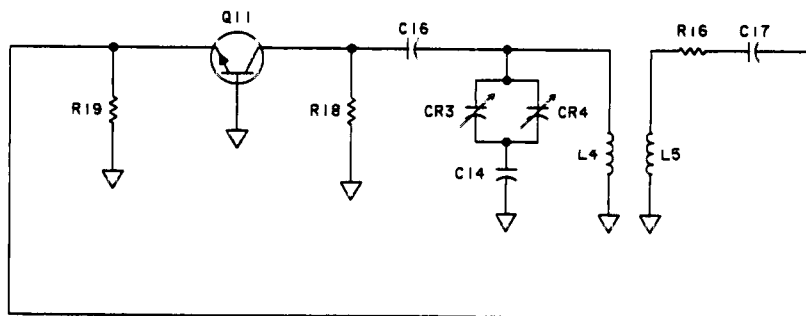

Figure A36-2. 200-300 MHz VCO Simplified Block Diagram

DIVIDE-BY-10 (BLOCK F)

This circuit amplifies the signal from block D. The signal is sent through a high-pass filter and divided by ten. The result is sent to the output switch (block E).

OUTPUT SWITCH (BLOCK E)

The output switch is a quad ECL NOR gate. For sweep widths between >0.1 MHz and <5 MHz the SW1 line is a TTL low, disables the loop amplifier as explained below:

1. SW1 goes (TTL) low.
2. the low SW1 line causes CR6 (in block A) to conduct and pull the base of Q9 (in block A) low
3. Q9 makes the output of U6A (in block A) go negative.
4. U6A biases varactor diodes CR3 and CR4 (in block C) on, disabling the VCO.

The low on SW1 also disables U2D by causing U2C to go to a high output level. U2B is enabled in this condition and routes the 15-30 MHz input from PLL2 VCO to the output.

For all other sweep conditions the SW1 line is high and the loop is enabled. In these instances the divided-by-ten VCO frequency (from block F) goes through U2D to the OUT 20-30 MHz line.

A36 PLL1 VCO Component-Level Troubleshooting

Table A36-1. A36 PLL1 VCO Pin I/O

Pin	Mnemonic	Levels	Source	Destination
1	GND	0V	A62 STAR GND	*G
16	GND	0V	A62 STAR GND	*G
2	DB8	TTL	*	*THRU A62R7 TO B
17	DB9	TTL	*	*THRU A62R8 TO B
3	DB10	TTL	*	*THRU A62R9 TO B
18	DB11	TTL	*	*THRU A62R10 TO B
4	LCK4	TTL (LOW TRUE)	XA59P1-52	*THRU A62R11 TO B
19	GND	0V	A62 STAR GND	*G
5	GND	0V	A62 STAR GND	*G
20	GND	0V	A62 STAR GND	*G
6	GND	0V	A62 STAR GND	*G
21	GND	0V	A62 STAR GND	*G
7	GND	0V	A62 STAR GND	*G
22	GND	0V	A62 STAR GND	*G
8	GND	0V	A62 STAR GND	*G
23	SW1	TTL	XA42P1-32	*E
9				
24	PH1	0 TO +5V	A6R12	A
10	GND	0V	A62 STAR GND	*G
25	PH2	0 TO +5V	A62R13	A
11	GND	0V	A62 STAR GND	*G
26	GND	0V	A62 STAR GND	*G
12	-10V	-10V	XA53P1-12,13,31,32	*THRU A62L8 TO G
27	-10V	-10V	XA53P1-12, 13, 31, 32	*THRU A62L8 TO G
13	+12V U1 ADJ	+10.5V	XA5P1-10	*THRU A62L2 TO G
28	+12V U1 ADJ	+10.5V	XA52P1-10	*THRU A62L2 TO G
14	GND	0V	A62 STAR GND	*G
29	GND	0V	A62 STAR GND	*G
15	+5.2V	+5.2V	XA52P1-17, 18,41,42	*THRU A62L1 TO G
30	+5.2V	+5.2V	XA52P1-17, 18, 41, 42	*THRU A62L1 TO G

A single letter in the source or destination column refers to a function block on this assembly schematic.

An asterisk (*) denotes multiple sources or destinations; refer to the A62 motherboard wiring list for a complete representation of signal sources and destinations.

A36 PLL1 VCO Component-Level Troubleshooting

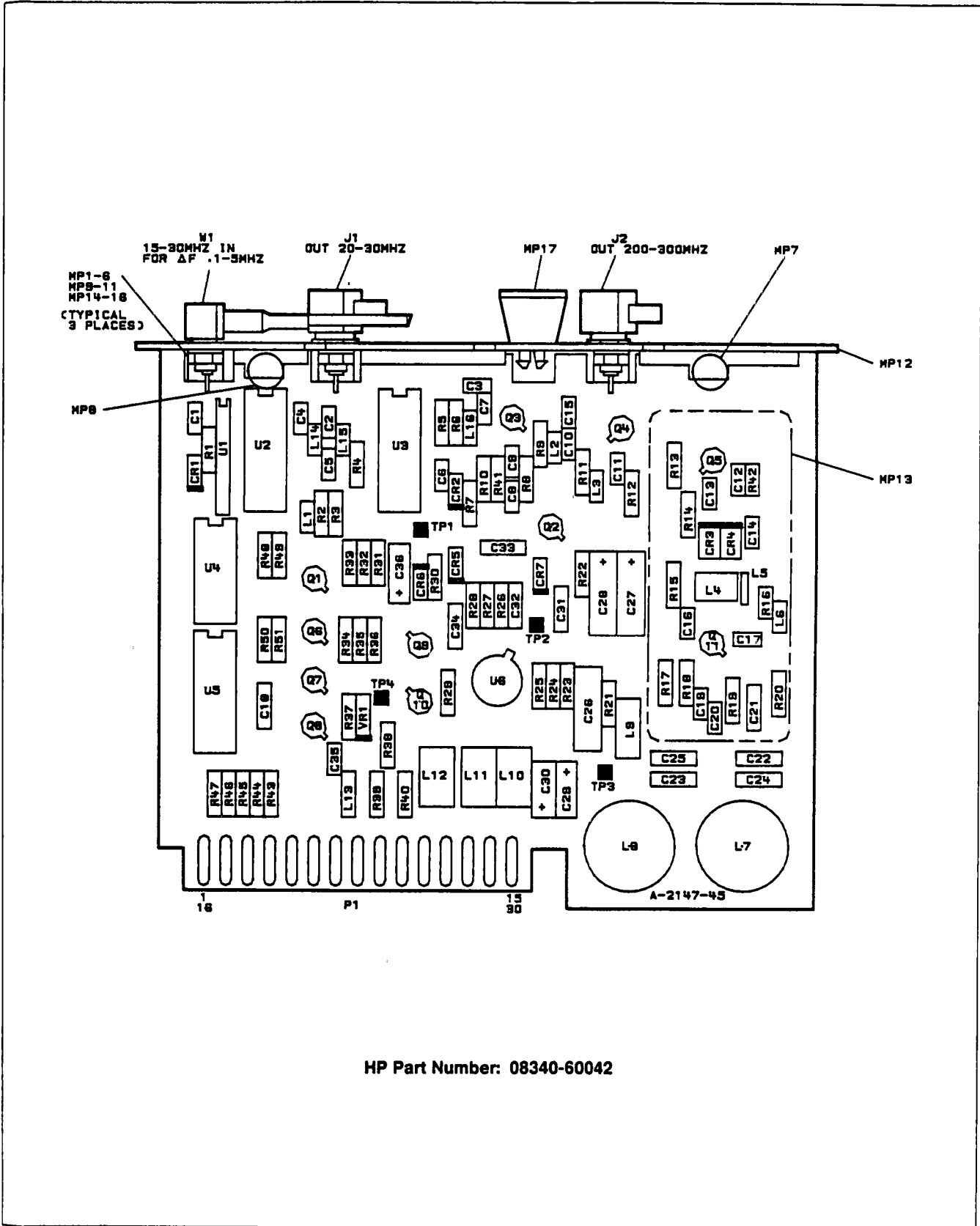

HP Part Number: 08340-60042

Figure A36-3. A36 PLL1 VCO Component Location Diagram

A36 PHASE LOCK LOOP 1 (PLL1)
VOLTAGE CONTROLLED
OSCILLATOR (VCO)
00-00-00042

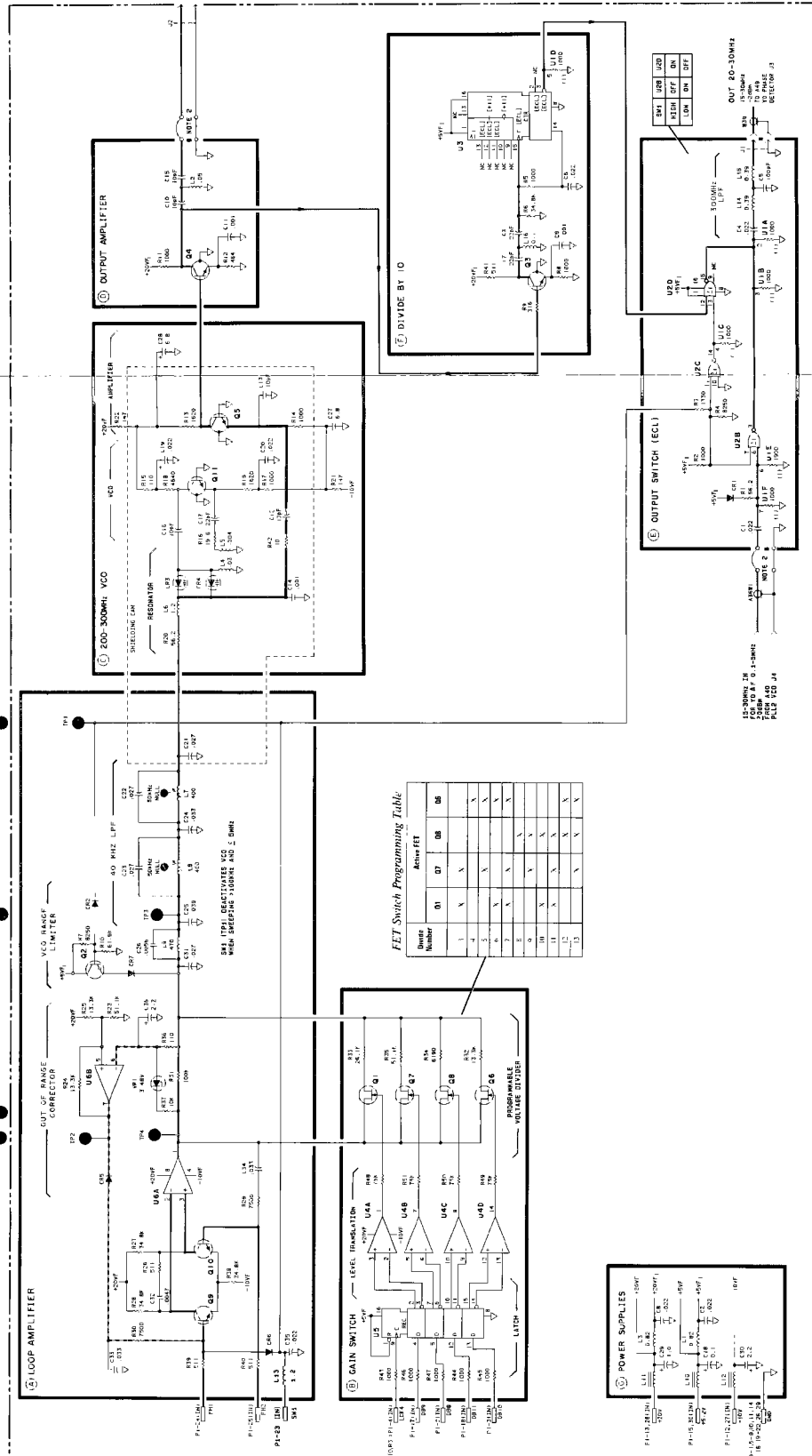

NOTES:
1. RESISTANCE VALUES SHOWN ARE IN OHMS.
2. UNLESS OTHERWISE SPECIFIED, ALL RESISTORS ARE 1% TOLERANCE.
3. UNLESS OTHERWISE SPECIFIED, ALL CAPACITORS ARE 5% TOLERANCE.
4. UNLESS OTHERWISE SPECIFIED, ALL CAPACITORS ARE 100PF.
5. UNLESS OTHERWISE SPECIFIED, ALL CAPACITORS ARE 100NF.
6. UNLESS OTHERWISE SPECIFIED, ALL CAPACITORS ARE 10UF.
7. UNLESS OTHERWISE SPECIFIED, ALL CAPACITORS ARE 1UF.
8. UNLESS OTHERWISE SPECIFIED, ALL CAPACITORS ARE 0.1UF.
9. UNLESS OTHERWISE SPECIFIED, ALL CAPACITORS ARE 0.01UF.
10. UNLESS OTHERWISE SPECIFIED, ALL CAPACITORS ARE 0.001UF.

FET Switch Programming Table

Switch Number	01	07	08	09
1	X	X	X	X
2	X	X	X	X
3	X	X	X	X
4	X	X	X	X
5	X	X	X	X
6	X	X	X	X
7	X	X	X	X
8	X	X	X	X
9	X	X	X	X
10	X	X	X	X
11	X	X	X	X
12	X	X	X	X
13	X	X	X	X
14	X	X	X	X
15	X	X	X	X

Figure A36-4. A36 PLL1 VCO Schematic Diagram
A36-7/A36-8
20/30 Loops

A36 PLL1 VCO Component-Level Troubleshooting

Table A36-2. A36 PLL1 VCO Replaceable Parts

Reference Designation	HP Part Number	C D	Qty	Description	Mfr Code	Mfr Part Number
A36	08340-60042	9	1	PLL1 VCO ASSEMBLY	28480	08340-60042
A36C1	0160-0574	3	8	CAPACITOR-FXD 022UF ± 20% 100VDC CER	28480	0160-0574
A36C2	0160-0574	3		CAPACITOR-FXD 022UF ± 20% 100VDC CER	28480	0160-0574
A36C3	0160-3875	3	3	CAPACITOR-FXD 22PF ± 5% 200VDC CER 0 ± 30	28480	0160-3875
A36C4	0160-0574	3		CAPACITOR-FXD 022UF ± 20% 100VDC CER	28480	0160-0574
A36C5	0160-3877	5	1	CAPACITOR-FXD 100PF ± 20% 200VDC CER	28480	0160-3877
A36C6	0160-0574	3		CAPACITOR-FXD 022UF ± 20% 100VDC CER	28480	0160-0574
A36C7	0160-3875	3		CAPACITOR-FXD 22PF ± 5% 200VDC CER 0 ± 30	28480	0160-3875
A36C8	0160-0574	3		CAPACITOR-FXD 022UF ± 20% 100VDC CER	28480	0160-0574
A36C9	0160-3878	6	3	CAPACITOR-FXD 1000PF ± 20% 100VDC CER	28480	0160-3878
A36C10	0160-3874	2	5	CAPACITOR-FXD 10PF ± 5PF 200VDC CER	28480	0160-3874
A36C11	0160-3878	6		CAPACITOR-FXD 1000PF ± 20% 100VDC CER	28480	0160-3878
A36C12	0160-3874	2		CAPACITOR-FXD 10PF ± 5PF 200VDC CER	28480	0160-3874
A36C13	0160-3874	2		CAPACITOR-FXD 10PF ± 5PF 200VDC CER	28480	0160-3874
A36C14	0160-3878	6		CAPACITOR-FXD 1000PF ± 20% 100VDC CER	28480	0160-3878
A36C15	0160-3874	2		CAPACITOR-FXD 10PF ± 5PF 200VDC CER	28480	0160-3874
A36C16	0160-3874	2		CAPACITOR-FXD 10PF ± 5PF 200VDC CER	28480	0160-3874
A36C17	0160-3875	3		CAPACITOR-FXD 22PF ± 5% 200VDC CER 0 ± 30	28480	0160-3875
A36C18	0160-4084	8	1	CAPACITOR-FXD 1UF ± 20% 50VDC CER	28480	0160-4084
A36C19	0160-0574	3		CAPACITOR-FXD 022UF ± 20% 100VDC CER	28480	0160-0574
A36C20	0160-0574	3		CAPACITOR-FXD 022UF ± 20% 100VDC CER	28480	0160-0574
A36C21	0160-4953	0	4	CAPACITOR-CER 027 UF 50VDC	28480	0160-4953
A36C22	0160-4953	0		CAPACITOR-CER 027 UF 50VDC	28480	0160-4953
A36C23	0160-4953	0		CAPACITOR-CER 027 UF 50VDC	28480	0160-4953
A36C24	0160-4951	8	3	CAPACITOR-FXD 033UF ± 5% 50VDC CER	28480	0160-4951
A36C25	0160-4952	9	1	CAPACITOR-FXD 039UF ± 5% 50VDC CER	28480	0160-4952
A36C26	0160-0158	9	1	CAPACITOR-FXD 5600PF ± 10% 200VDC POLYE	28480	0160-0158
A36C27	0180-0116	1	2	CAPACITOR-FXD 6.8UF ± 10% 35VDC TA	56289	150D685X9035B2
A36C28	0180-0116	1		CAPACITOR-FXD 6.8UF ± 10% 35VDC TA	56289	150D685X9035B2
A36C29	0180-0291	3	1	CAPACITOR-FXD 1UF ± 10% 35VDC TA	56289	150D105X9035A2
A36C30	0180-0197	8	2	CAPACITOR-FXD 2.2UF ± 10% 20VDC TA	56289	150D225X9020A2
A36C31	0160-4953	0		CAPACITOR-CER 027 UF 50VDC	28480	0160-4953
A36C32	0160-4298	6	1	CAPACITOR-FXD 4700PF ± 20% 250VDC CER	56289	C067F251H472MS22-CDH
A36C33	0160-4951	8		CAPACITOR-FXD 033UF ± 5% 50VDC CER	28480	0160-4951
A36C34	0160-4951	8		CAPACITOR-FXD 033UF ± 5% 50VDC CER	28480	0160-4951
A36C35	0160-0574	3		CAPACITOR-FXD 022UF ± 20% 100VDC CER	28480	0160-0574
A36C36	0180-0197	8		CAPACITOR-FXD 2.2UF ± 10% 20VDC TA	56289	150D225X9020A2
A36CR1	1901-0040	1	5	DIODE-SWITCHING 30V 50MA 2NS DO-35	28480	1901-0040
A36CR2	1901-0040	1		DIODE-SWITCHING 30V 50MA 2NS DO-35	28480	1901-0040
A36CR3	0122-0085	1	2	DIODE-VVC 2.2PF 7% C3/C25-MIN=4.5	02032	SMV1288
A36CR4	0122-0085	1		DIODE-VVC 2.2PF 7% C3/C25-MIN=4.5	02032	SMV1288
A36CR5	1901-0040	1		DIODE-SWITCHING 30V 50MA 2NS DO-35	28480	1901-0040
A36CR6	1901-0040	1		DIODE-SWITCHING 30V 50MA 2NS DO-35	28480	1901-0040
A36CR7	1901-0040	1		DIODE-SWITCHING 30V 50MA 2NS DO-35	28480	1901-0040
A36J1	1250-0690	6	2	CONNECTOR-RF MALE SMB	28480	1250-0690
A36J2	1250-0690	6		CONNECTOR-RF MALE SMB	28480	1250-0690
A36L1	9100-2257	6	2	INDUCTOR RF-CH-MLD 820NH 10% 105DX 26LG	28480	9100-2257
A36L2	9100-2891	4	1	INDUCTOR RF-CH-MLD 50NH 10% 105DX 26LG	28480	9100-2891
A36L3	9100-2257	6		INDUCTOR RF-CH-MLD 820NH 10% 105DX 26LG	28480	9100-2257
A36L4	85660-80004	4	1	INDUCTOR-30 NH	28480	85660-80004
A36L5	85660-80005	5	1	INDUCTOR-4 NH	28480	85660-80005
A36L6	9100-2258	7	2	INDUCTOR RF-CH-MLD 1.2UH 10% 105DX 26LG	28480	9100-2258
A36L7	85660-80008	8	2	INDUCTOR-ADJ 4 MH	28480	85660-80008
A36L8	85660-80008	8		INDUCTOR-ADJ 4 MH	28480	85660-80008
A36L9	9100-1647	6	1	INDUCTOR RF-CH-MLD 470UH 5% 2DX 45LG	28480	9100-1647
A36L10	9100-1788	6	3	CHOKE-WIDE BAND ZMAX=680 OHM% 180 MHZ	02114	VK200 20/48
A36L11	9100-1788	6		CHOKE-WIDE BAND ZMAX=680 OHM% 180 MHZ	02114	VK200 20/48
A36L12	9100-1788	6		CHOKE-WIDE BAND ZMAX=680 OHM% 180 MHZ	02114	VK200 20/48
A36L13	9100-2258	7		INDUCTOR RF-CH-MLD 1.2UH 10% 105DX 26LG	28480	9100-2258
A36L14	9100-2254	3	2	INDUCTOR RF-CH-MLD 390NH 10% 105DX 26LG	28480	9100-2254
A36L15	9100-2254	3		INDUCTOR RF-CH-MLD 390NH 10% 105DX 26LG	28480	9100-2254

A36 PLL1 VCO Component-Level Troubleshooting

Table A36-2. A36 PLL1 VCO Replaceable Parts

Reference Designation	HP Part Number	C D	Qty	Description	Mfr Code	Mfr Part Number
A36L16	9100-2247	4	1	INDUCTOR RF-CH-MLD 100NH 10% .105DX.28LG	28480	9100-2247
A36MP1	2190-0124	4	6	WASHER-LK INTL T NO. 10 .195-IN-ID	28480	2190-0124
A36MP2	2190-0124	4		WASHER-LK INTL T NO. 10 .195-IN-ID	28480	2190-0124
A36MP3	2190-0124	4		WASHER-LK INTL T NO. 10 .195-IN-ID	28480	2190-0124
A36MP4	2190-0124	4		WASHER-LK INTL T NO. 10 .195-IN-ID	28480	2190-0124
A36MP5	2190-0124	4		WASHER-LK INTL T NO. 10 .195-IN-ID	28480	2190-0124
A36MP6	2190-0124	4		WASHER-LK INTL T NO. 10 .195-IN-ID	28480	2190-0124
A36MP7	2200-0101	0	2	SCREW-MACH 4-40 188-IN-LG PAN-HD-POZI	00000	2190-0124
A36MP8	2200-0101	0		SCREW-MACH 4-40 188-IN-LG PAN-HD-POZI	00000	ORDER BY DESCRIPTION
A36MP9	86701-40001	9	1	EXTRACTOR PC BOARD	28480	86701-40001
A36MP10	2950-0078	9		NUT-HEX-DBL-CHAM 10-32-THD .067-IN-THK	28480	2950-0078
A36MP11	2950-0078	9		NUT-HEX-DBL-CHAM 10-32-THD .067-IN-THK	28480	2950-0078
A36MP12	08340-20094	7	1	COVER-PC PLL1 VCO	28480	08340-20094
A36MP13	85660-00038	6	1	SHIELDING CAN	28480	85660-00038
A36MP14	85660-20068	4	3	GROUND LUG	28480	85660-20068
A36MP15	85660-20068	4		GROUND LUG	28480	85660-20068
A36MP16	85660-20068	4		GROUND LUG	28480	85660-20068
A36Q1	1855-0420	2	4	TRANSISTOR J-FET 2N4391 N-CHAN D-MODE	01295	2N4391
A36Q2	1854-0023	9	3	TRANSISTOR NPN SI TO-18 PD=360MW	28480	1854-0023
A36Q3	1854-0345	8	4	TRANSISTOR NPN 2N5179 SI TO-72 PD=200MW	04713	2N5179
A36Q4	1854-0345	8		TRANSISTOR NPN 2N5179 SI TO-72 PD=200MW	04713	2N5179
A36Q5	1854-0345	8		TRANSISTOR NPN 2N5179 SI TO-72 PD=200MW	04713	2N5179
A36Q6	1855-0420	2		TRANSISTOR J-FET 2N4391 N-CHAN D-MODE	01295	2N4391
A36Q7	1855-0420	2		TRANSISTOR J-FET 2N4391 N-CHAN D-MODE	01295	2N4391
A36Q8	1855-0420	2		TRANSISTOR J-FET 2N4391 N-CHAN D-MODE	01295	2N4391
A36Q9	1854-0023	9		TRANSISTOR NPN SI TO-18 PD=360MW	28480	1854-0023
A36Q10	1854-0023	9		TRANSISTOR NPN SI TO-18 PD=360MW	28480	1854-0023
A36Q11	1854-0345	8		TRANSISTOR NPN 2N5179 SI TO-72 PD=200MW	04713	2N5179
A36R1	0757-0395	1	2	RESISTOR 56 2 1% 125W F TC=0±100	24546	C4-1/8-T0-56R2-F
A36R2	0757-0280	3	11	RESISTOR 1K 1% 125W F TC=0±100	24546	C4-1/8-T0-1001-F
A36R3	0757-0317	7	1	RESISTOR 1.33K 1% 125W F TC=0±100	24546	C4-1/8-T0-1331-F
A36R4	0757-0441	8	2	RESISTOR 8.25K 1% 125W F TC=0±100	24546	C4-1/8-T0-8251-F
A36R5	0757-0280	3		RESISTOR 1K 1% 125W F TC=0±100	24546	C4-1/8-T0-1001-F
A36R6	0757-0123	3	4	RESISTOR 34.8K 1% 125W F TC=0±100	28480	0757-0123
A36R7	0757-0441	8		RESISTOR 8.25K 1% 125W F TC=0±100	24546	C4-1/8-T0-8251-F
A36R8	0757-0280	3		RESISTOR 1K 1% 125W F TC=0±100	24546	C4-1/8-T0-1001-F
A36R9	0698-3444	1	1	RESISTOR 316 1% 125W F TC=0±100	24546	C4-1/8-T0-316R-F
A36R10	0757-0480	1	1	RESISTOR 61.9K 1% 125W F TC=0±100	24546	C4-1/8-T0-6192-F
A36R11	0757-0280	3		RESISTOR 1K 1% 125W F TC=0±100	24546	C4-1/8-T0-1001-F
A36R12	0698-0082	7	1	RESISTOR 464 1% 125W F TC=0±100	24546	C4-1/8-T0-4640-F
A36R13	0757-0428	1	2	RESISTOR 1.62K 1% 125W F TC=0±100	24546	C4-1/8-T0-1621-F
A36R14	0757-0280	3		RESISTOR 1K 1% 125W F TC=0±100	24546	C4-1/8-T0-1001-F
A36R15	0757-0402	1	2	RESISTOR 110 1% 125W F TC=0±100	24546	C4-1/8-T0-111-F
A36R16	0698-7195	7	1	RESISTOR 19.6 1% 05W F TC=0±100	24546	C3-1/8-T0-19R6-F
A36R17	0757-0280	3		RESISTOR 1K 1% 125W F TC=0±100	24546	C4-1/8-T0-1001-F
A36R18	0698-3155	1	1	RESISTOR 4.84K 1% 125W F TC=0±100	24546	C4-1/8-T0-4641-F
A36R19	0757-0428	1		RESISTOR 1.62K 1% 125W F TC=0±100	24546	C4-1/8-T0-1621-F
A36R20	0757-0395	1		RESISTOR 56.2 1% 125W F TC=0±100	24546	C4-1/8-T0-56R2-F
A36R21	0698-3438	3	2	RESISTOR 147 1% 125W F TC=0±100	24546	C4-1/8-T0-147R-F
A36R22	0698-3438	3		RESISTOR 147 1% 125W F TC=0±100	24546	C4-1/8-T0-147R-F
A36R23	0757-0458	7	2	RESISTOR 51.1K 1% 125W F TC=0±100	24546	C4-1/8-T0-5112-F
A36R24	0757-0289	2	3	RESISTOR 13.3K 1% 125W F TC=0±100	19701	MF4C1/8-T0-1332-F
A36R25	0757-0289	2		RESISTOR 13.3K 1% 125W F TC=0±100	19701	MF4C1/8-T0-1332-F
A36R26	0757-0416	7	4	RESISTOR 511 1% 125W F TC=0±100	24546	C4-1/8-T0-511R-F
A36R27	0757-0123	3		RESISTOR 34.8K 1% 125W F TC=0±100	28480	0757-0123
A36R28	0757-0123	3		RESISTOR 34.8K 1% 125W F TC=0±100	28480	0757-0123
A36R29	0757-0440	7	2	RESISTOR 7.5K 1% 125W F TC=0±100	24546	C4-1/8-T0-7501-F
A36R30	0757-0440	7		RESISTOR 7.5K 1% 125W F TC=0±100	24546	C4-1/8-T0-7501-F
A36R31	0757-0465	6	1	RESISTOR 100K 1% 125W F TC=0±100	24546	C4-1/8-T0-1003-F
A36R32	0757-0289	2		RESISTOR 13.3K 1% 125W F TC=0±100	19701	MF4C1/8-T0-1332-F
A36R33	0698-3159	5	1	RESISTOR 26.1K 1% 125W F TC=0±100	24546	C4-1/8-T0-2612-F
A36R34	0757-0290	5	1	RESISTOR 8.19K 1% 125W F TC=0±100	19701	MF4C1/8-T0-6191-F
A36R35	0757-0458	7		RESISTOR 51.1K 1% 125W F TC=0±100	24546	C4-1/8-T0-5112-F

A36 PLL1 VCO Component-Level Troubleshooting

Table A36-2. A36 PLL1 VCO Replaceable Parts

Reference Designation	HP Part Number	C D	Qty	Description	Mfr Code	Mfr Part Number
A36R36	0757-0402	1		RESISTOR 110 1% .125W F TC=0±100	24546	C4-1/8-T0-111-F
A36R37	0757-0442	9	1	RESISTOR 10K 1% .125W F TC=0±100	24546	C4-1/8-T0-1002-F
A36R38	0757-0123	3		RESISTOR 34 8K 1% .125W F TC=0±100	28480	0757-0123
A36R39	0757-0416	7		RESISTOR 511 1% .125W F TC=0±100	24546	C4-1/8-T0-511R-F
A36R40	0757-0416	7		RESISTOR 511 1% .125W F TC=0±100	24546	C4-1/8-T0-511R-F
A36R41	0757-0416	7		RESISTOR 511 1% .125W F TC=0±100	24546	C4-1/8-T0-511R-F
A36R42	0698-7188	8	1	RESISTOR 10 1% .05W F TC=0±100	24546	C3-1/8-T0-10R-F
A36R43	0757-0280	3		RESISTOR 1K 1% .125W F TC=0±100	24546	C4-1/8-T0-1001-F
A36R44	0757-0280	3		RESISTOR 1K 1% .125W F TC=0±100	24546	C4-1/8-T0-1001-F
A36R45	0757-0280	3		RESISTOR 1K 1% .125W F TC=0±100	24546	C4-1/8-T0-1001-F
A36R46	0757-0280	3		RESISTOR 1K 1% .125W F TC=0±100	24546	C4-1/8-T0-1001-F
A36R47	0757-0280	3		RESISTOR 1K 1% .125W F TC=0±100	24546	C4-1/8-T0-1001-F
A36R48	0757-0462	3	4	RESISTOR 75K 1% .125W F TC=0±100	24546	C4-1/8-T0-7502-F
A36R49	0757-0462	3		RESISTOR 75K 1% .125W F TC=0±100	24546	C4-1/8-T0-7502-F
A36R50	0757-0462	3		RESISTOR 75K 1% .125W F TC=0±100	24546	C4-1/8-T0-7502-F
A36R51	0757-0462	3		RESISTOR 75K 1% .125W F TC=0±100	24546	C4-1/8-T0-7502-F
A36TP1	0360-0535	0	4	TERMINAL TEST POINT PCB	00000	ORDER BY DESCRIPTION
A36TP2	0360-0535	0		TERMINAL TEST POINT PCB	00000	ORDER BY DESCRIPTION
A36TP3	0360-0535	0		TERMINAL TEST POINT PCB	00000	ORDER BY DESCRIPTION
A36TP4	0360-0535	0		TERMINAL TEST POINT PCB	00000	ORDER BY DESCRIPTION
A36U1	1810-0204	6	1	NETWORK-RES 8-SIP 1 0K OHM X 7	01121	208A102
A36U2	1820-0802	1	1	IC GATE ECL NOR QUAD 2-INP	04713	MC10102P
A36U3	1820-1888	5	1	IC PRESCR ECL	04713	MC12013L
A36U4	1826-0161	7	1	IC OP AMP GP QUAD 14-DIP-P PKG	04713	MLM324P
A36U5	1820-1195	7	1	IC FF TTL LS D-TYPE POS-EDGE-TRIG COM	01295	SN74LS175N
A36U6	1826-0092	3	1	IC OP AMP GP DUAL TO-99 PKG	28480	1826-0092
A36VR1	1902-3048	7	1	DIODE-ZNR 3 48V 5% DO-35 PD= 4W	28480	1902-3048
A36W1	08340-60106	6	1	CABLE ASSEMBLY-A36	28480	08340-60106

A37 Phase Lock Loop 1 Divider Circuit Description

ASSEMBLY PURPOSE

The A37 PLL1 assembly contains a programmable frequency divider and a phase/frequency detector.

The A60 processor assembly programs the frequency divider to divide a 36 to 139.7 MHz input frequency down to a 5 MHz fixed frequency. The resultant 5 MHz signal is compared with a 5 MHz reference in the phase/frequency detector. The detector output controls the frequency of the PLL1 VCO (voltage-controlled oscillator).

The divide number is always between 3.60 and 13.97. The integer part is coded in binary while the fractional part is coded in binary coded decimal (BCD).

The PLL1 divider works using pulse swallowing. Figure A37-1 shows the basic diagram of a pulse swallowing divider.

The rate multiplier (fractional divider) is formed by 2 TTL decade rate multiplier ICs. The input to the rate multiplier is the output of the overall divider. For 100 divider output pulses, the rate multiplier will output between 0 to 99 pulses. The pulses out of the rate multiplier are not necessarily evenly spaced, but will always be $X/100$ times the number of input pulses to the rate multiplier. Each time the rate multiplier outputs a pulse, the input signal in the divide-by-N block is effectively ignored for one entire input pulse. This means that $N+1$ input pulses will transpire before the next output pulse will occur (i.e. the integer divide number is effectively $N+1$ for this particular output pulse). If the rate multiplier does not output a pulse, then the divide-by-N continues to divide by N normally.

The result of this is that for 100 output pulses, the integer counter was dividing by $N+1$ for X output pulses, and dividing by N for the remaining $100-X$ output pulses. The total number of input pulses that occurred was $(N+1)*X + N*(100-X) = 100*N + X$. The divide number (input pulses divided by output pulses) is $(100*N + X)/100 = N + X/100$. So N becomes the integer portion of the overall divide number, and X becomes fractional part. For example: to divide by 8.57, the divide-by-N would be set to 8 and the rate multiplier would be programmed to 57.

Refer to the "Frequency Range and CW Mode Accuracy" Performance Test for use as a troubleshooting aid.

DIVIDE-BY-2 (BLOCK A)

The input amplifier stage performs two functions. First, it is a three-stage limiting amplifier. Second, it is an ECL-TTL level translator required by the subsequent divider. The divider is a D-type flip flop which divides the input amplifier output by two.

A37 PLL1 Divider Circuit Description

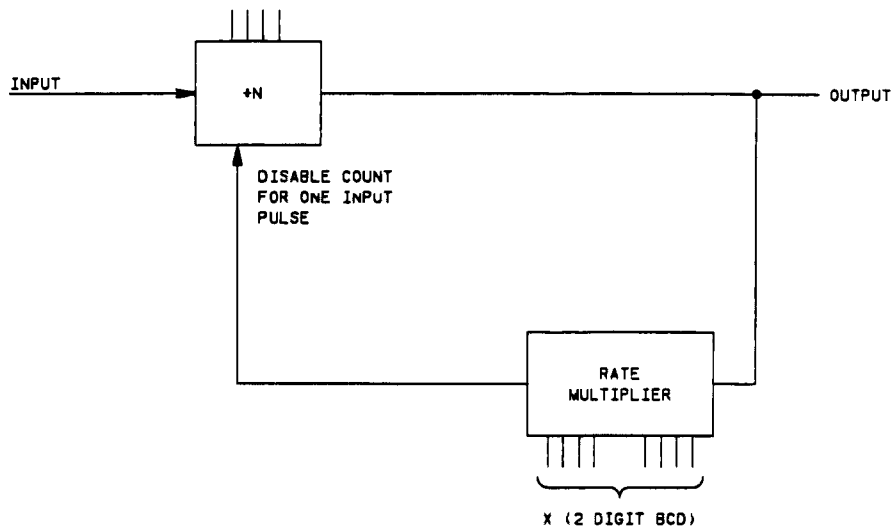

Figure A37-1. Fractional Division Using Pulse Swallowing

INPUT LATCH (BLOCK B)

This block contains two latches that store the divider programming number. The latched outputs for the divide-by-N (block C) are level translated from TTL to ECL levels. The number is clocked into the latches with the LCK4 signal.

DIVIDE-BY-N (BLOCK C)

The 4-bit binary counter which is programmed with the integer part (3 to 13) of the divide number. It is an ECL device which is in one of three states at all times:

- Counting down
- Loading
- Holding

The state of the counter is determined by the status of TP6 LNLOAD (low N load) and TP5 HSWALLOW (high swallow input pulse). The input clock is the output of the divide-by-2 (block A) circuit (TP3). This output is also the clock for U14A, U14B and U4B. The divider is loaded with the integer portion of the divide number, and then decrements at each clock pulse until the count of 2 is reached. At this time, the wire-OR'd bits (TP8) are 0 and LNLOAD (TP6) is set up to be clocked low on the following clock pulse. On the next rising clock pulse, the counter is loaded with the integer divide number, LNLOAD goes low for one clock cycle and the divider output (TP13) goes low for two clock cycles. This operation repeats every N clock pulses unless the swallow control causes HSWALLOW to go high. Figure A36-2 shows the operation of the divide-by-N without a HSWALLOW pulse. U4B is a synchronously cleared, asynchronously set flip-flop, due to its D and S inputs tied together. Its relationship to TP6 LNLOAD is also shown in Figure A37-2.

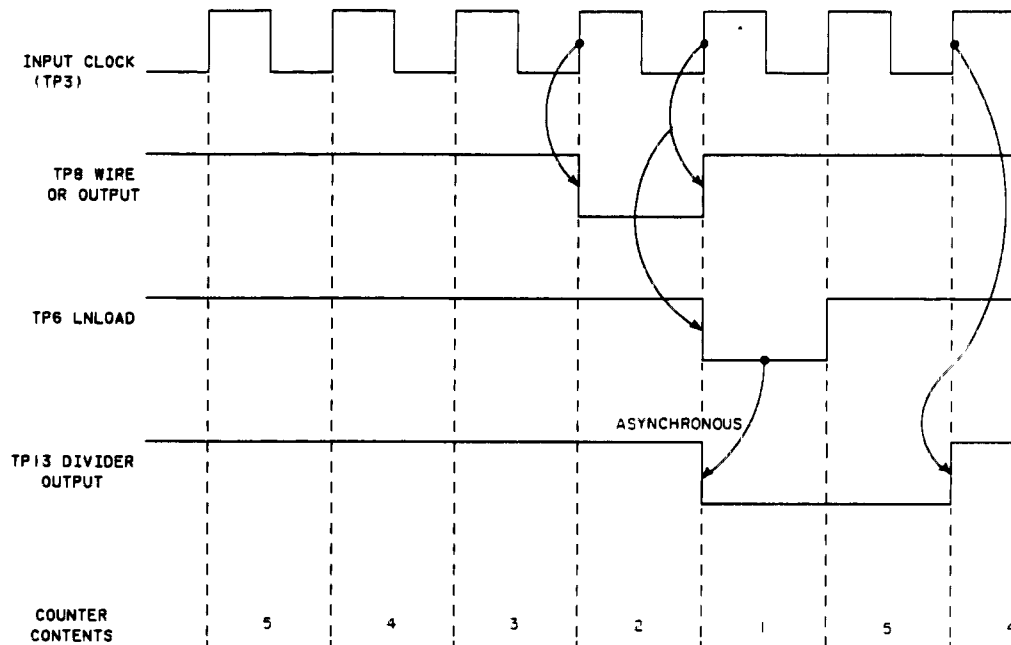

Figure A37-2. N-Divider Operation; N=5 (HSWALLOW not used)

FRACTIONAL DIVIDER (BLOCK D)

HSWALLOW (TP5) output is synchronous with the divide-by-N output at TP13. If HSWALLOW is low when the divide-by-N (TP13) outputs a pulse, the fractional divider has no effect on the divide-by-N counter. If HSWALLOW is high when the divide-by-N (TP12) outputs a pulse, the divide-by-N divider U12 ignores one input (clock) pulse, and the N divider becomes a divide by N+1. The following paragraphs describe this process more thoroughly.

U1 and U2 are TTL decade rate multipliers. U3B and Q1 translate ECL levels to TTL. When the divide-by-N (TP13) outputs a pulse and the fractional divider HSWALLOW (TP5) outputs a pulse, TP7 goes low and then high synchronously with the output pulse (TP13). The low-to-high transition of TP7 will cause low SWALLOW ENABLE to go high. LOW SWALLOW ENABLE is connected to the reset of U14A. As long as low SWALLOW ENABLE is high, HSWALLOW is forced low independently of its clock changing. But if rate multipliers U1 and U2 cause a pulse on TP7, low SWALLOW ENABLE is left low, and HSWALLOW is allowed to go high when the next output pulse (TP13) occurs.

The only time that states can change in the Swallow Control is when there is an output pulse. The swallow control must decide to do one of two things for the subsequent output pulse (TP13): To divide by either N or N+1. To divide by N+1, the HSWALLOW line is clocked high for only one input clock pulse. To divide by N, the divide-by-N block is not interrupted. The decision to swallow an input pulse is made by considering two things; whether the rate multipliers U1 and U2 output a pulse, and the state of low SWALLOW ENABLE prior to the output pulse (TP13).

All four possible combinations are shown in Figure A37-3.

Figure A37-3 shows that:

- Whenever low SWALLOW ENABLE is high prior to the output pulse (TP13), HSWALLOW always remains low throughout the sequence, and no input pulse is swallowed.
- Whenever the rate multipliers U1 and U2 output a pulse, low SWALLOW ENABLE remains in the low state, regardless of the previous state of the line.

The definition of LOW SWALLOW ENABLE and HSWALLOW can be stated:

- low SWALLOW ENABLE – When low, an input pulse is swallowed during the next output pulse (TP13) sequence.
- HSWALLOW – When high, causes U12 to hold its count. HSWALLOW is high for a period of 1 input clock pulse, and is timed such that the counter is never loading and holding at the same time.

R10 and C11 cause a time delay which avoids timing problems when HSWALLOW signals go to U15 pin 10 and (through U3) to pin eleven at the same instant. The signal at pin 10 is always delayed so that a timing problem never occurs.

A37 PLL1 Divider Circuit Description

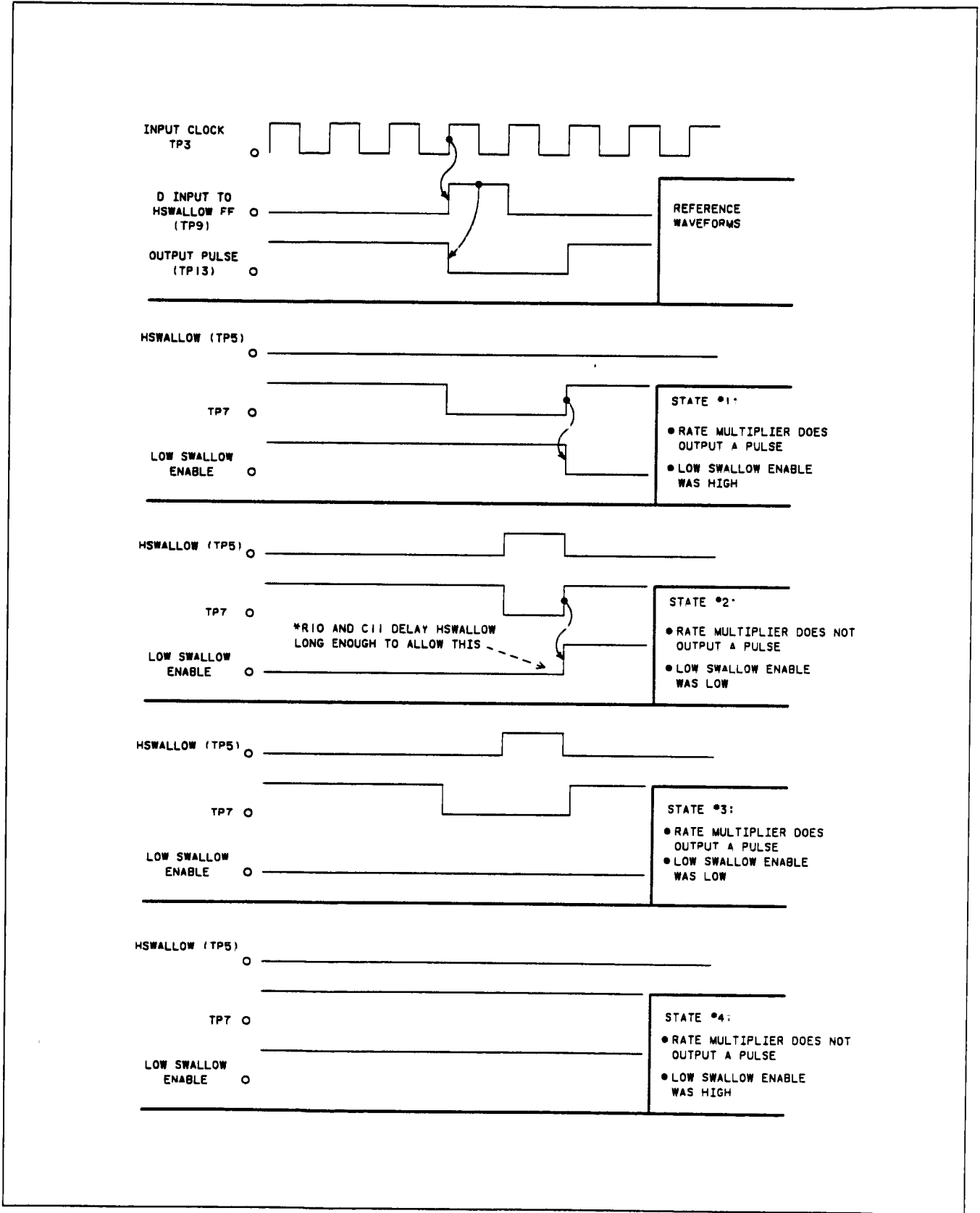

Figure A37-3. Possible Fractional Divider Sequences

PHASE/FREQUENCY DETECTOR (BLOCK E)

The Phase/Frequency Detector compares the divider output with a 5 MHz reference frequency. When the two inputs are in phase, the outputs are ECL high, approximately +4 volts, with very narrow pulses at a 5 MHz rate. When the inputs are the same frequency but different in phase, one output line is a pulse with a width corresponding to the phase difference; the other output is high with very narrow pulses. If the input frequencies are different, the outputs are pulses of varying widths, but the average DC voltage levels are different. The polarity of the average DC voltage will change, depending on which input frequency is higher.

REFERENCE DIVIDE-BY-2 (BLOCK F)

U7C is an linear buffer amplifier that generates the proper level for ECL (approximately +3 volts low and +4 volts high). U15A divides the 10 MHz input by 2 and applies this 5 MHz to the phase/frequency detector.

PHASE LOCK INDICATOR (BLOCK G)

The input to the phase lock indicator is the wire-OR outputs of the phase/frequency detector in block E. When the loop is locked this signal is ECL low (approximately 3 volts). The DC voltage at the base of Q3 is lower than that at the base of Q2, so Q3 is on and Q2 is off. If the loop unlocks, the input to the phase lock indicator consists of varying width pulses, the average DC value of which is about half way between a logic low and high. The voltage divider consisting of R35 and R15 causes the voltage at the base of Q2 to be lower than the base of Q3, so Q2 turns on indicating an unlock condition.

A37 PLL1 Divider Component-Level Troubleshooting

Table A37-1. A37 PLL1 Divider Pin I/O

Pin	Mnemonic	Levels	Source	Destination
1 19	DB0 DB1	TTL TTL	XA60P1-20 XA60P1-76	*B *B
2 20	DB2 DB3	TTL TTL	XA60P1-21 XA60P1-77	*B *B
3 21	DB4 DB5	TTL TTL	XA60P1-22 XA60P1-78	*B *B
4 22	DB6 DB7	TTL TTL	XA60P1-23 XA60P1-79	*B *B
5 23	DB8 DB9	TT; TTL	* *	*B *B
6 24	GND GND	0V 0V	A62 STAR GND A62 STAR GND	*H *H
7 25	DB10 DB11	TTL TTL	* *	*B *B
8 26	LCK4 HULI	TTL (LOW TRUE) TTL (HIGH TRUE)	XA59P1-52 *G	*B XA59P1-106
9 27	GND GND	0V 0V	A62 STAR GND A62 STAR GND	*H *H
10 28	GND GND	0V 0V	A62 STAR GND A62 STAR GND	*H *H
11 29	PH1 GND	0 TO +5V 0V	E A62 STAR GND	XA36P1-24 *H
12 30	PH2 GND	0 TO +5V 0V	E A62 STAR GND	XA36P1-25 *H
13 31	GND GND	0V 0V	A62 STAR GND A62 STAR GND	*H *H
14 32	GND GND	0V 0V	A62 STAR GND A62 STAR GND	*H *H
15 33	GND GND	0V 0V	A62 STAR GND A62 STAR GND	*H *H
16 34	GND GND	0V 0V	A62 STAR GND A62 STAR GND	*H *H
17 32	GND GND	0V 0V	A62 STAR GND A62 STAR GND	*H *H
18 36	+5.2V +5.2V	+5.2V +5.2V	XA5201-17, 18, 41, 42 XA52P1-17, 18, 41, 42	*THRU A62L3 TO H *THRU A62L3 TO H

A single letter in the source or destination column refers to a function block on this assembly schematic.

An asterisk (*) denotes multiple sources or destinations; refer to the A62 motherboard wiring list for a complete representation of signal sources and destinations.

A37 PLL1 Divider Component-Level Troubleshooting

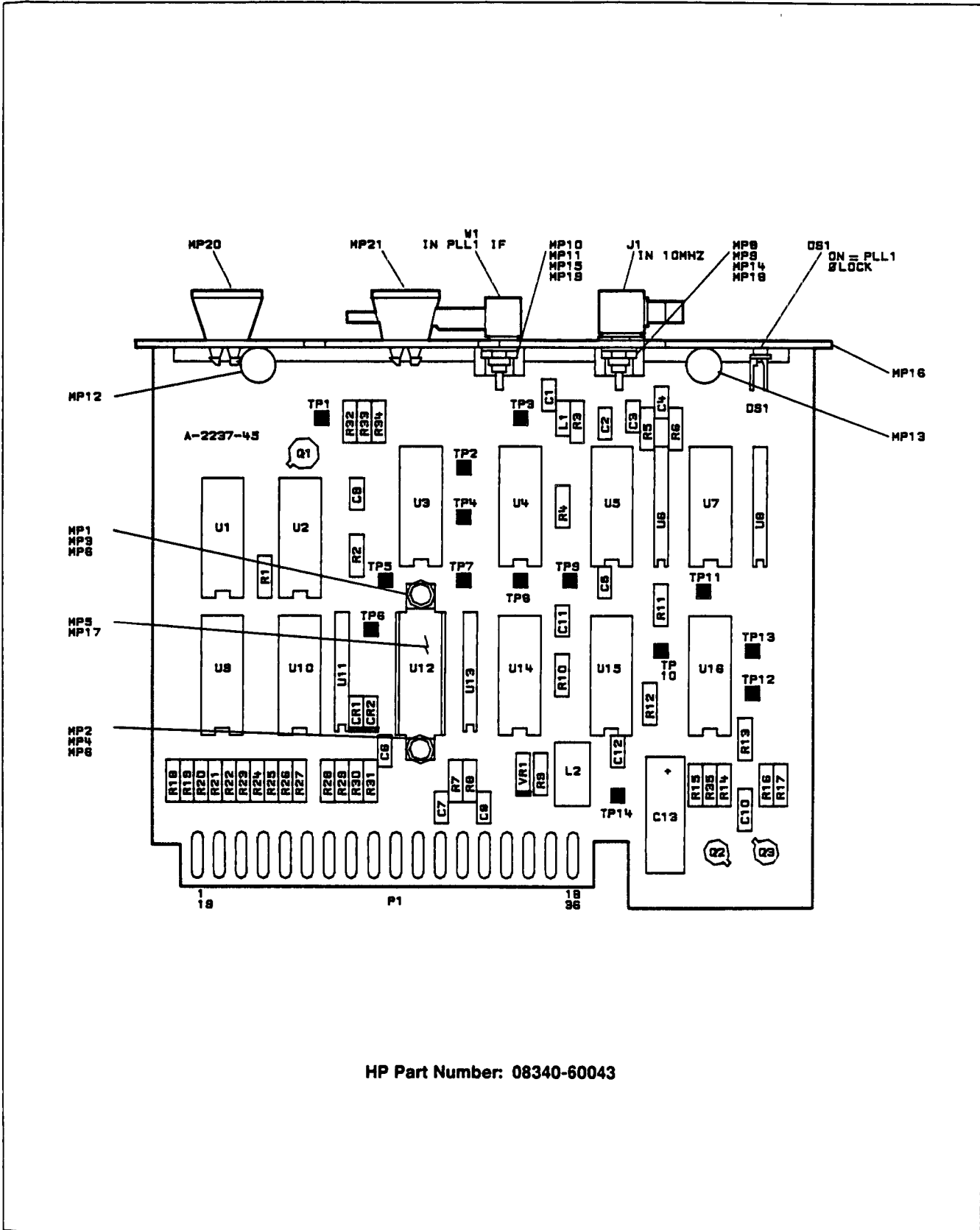

HP Part Number: 08340-60043

Figure A37-4. A37 PLL1 Divider Component Location Diagram

RESISTANCE VALUES SHOWN ARE IN OHMS, CAPACITANCE IN MICROFARADS, AND INDUCTANCE IN MILLIHENRIES UNLESS OTHERWISE NOTED.

ALL AND EXTRA CRYSTAL OSCILLATORS ARE ELECTRICALLY CONNECTED TO THE PC BOARD THROUGH SOLDERED 24 GAUGE FINE WIRES. THE CRYSTAL OSCILLATORS ARE ELECTRICALLY CONNECTED TO THE PC BOARD THROUGH MECHANICAL SCREEN CONNECTIONS IN THE ASSEMBLY COVER PLATE.

1. RESISTANCE VALUES SHOWN ARE IN OHMS, CAPACITANCE IN MICROFARADS, AND INDUCTANCE IN MILLIHENRIES UNLESS OTHERWISE NOTED.
2. ALL AND EXTRA CRYSTAL OSCILLATORS ARE ELECTRICALLY CONNECTED TO THE PC BOARD THROUGH SOLDERED 24 GAUGE FINE WIRES. THE CRYSTAL OSCILLATORS ARE ELECTRICALLY CONNECTED TO THE PC BOARD THROUGH MECHANICAL SCREEN CONNECTIONS IN THE ASSEMBLY COVER PLATE.

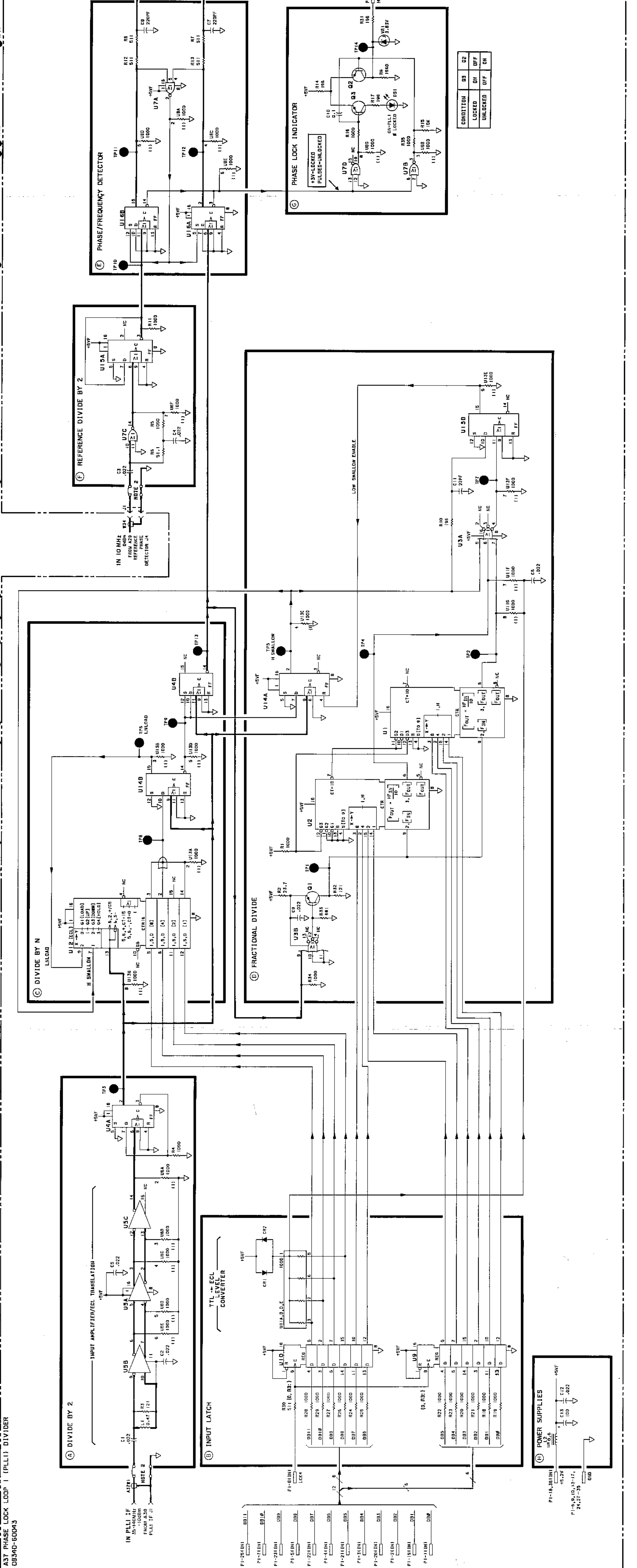

A37 PHASE LOCK LOOP 1 (PLL1) DIVIDER
68340-60043

A37 PLL1 Divider Component-Level Troubleshooting

Table A37-2. A37 PLL1 Divider Replaceable Parts

Reference Designation	HP Part Number	C D	Qty	Description	Mfr Code	Mfr Part Number
A37	08340-60043	0	1	PLL1 DIVIDER ASSEMBLY	28480	08340-60043
A37C1	0160-0574	3	8	CAPACITOR-FXD 022UF ±20% 100VDC CER	28480	0160-0574
A37C2	0160-0574	3		CAPACITOR-FXD 022UF ±20% 100VDC CER	28480	0160-0574
A37C3	0160-0574	3		CAPACITOR-FXD 022UF ±20% 100VDC CER	28480	0160-0574
A37C4	0160-0574	3		CAPACITOR-FXD 022UF ±20% 100VDC CER	28480	0160-0574
A37C5	0160-0574	3		CAPACITOR-FXD 022UF ±20% 100VDC CER	28480	0160-0574
A37C6	0160-0574	3		CAPACITOR-FXD 022UF ±20% 100VDC CER	28480	0160-0574
A37C7	0160-0570	9	2	CAPACITOR-FXD 220PF ±20% 100VDC CER	20932	5024EM100RD221M
A37C8	0160-0570	9		CAPACITOR-FXD 220PF ±20% 100VDC CER	20932	5024EM100RD221M
A37C9	0160-0574	3		CAPACITOR-FXD 022UF ±20% 100VDC CER	28480	0160-0574
A37C10	0160-4084	8	1	CAPACITOR-FXD 1UF ±20% 50VDC CER	28480	0160-4084
A37C11	0160-3875	3	1	CAPACITOR-FXD 22PF ±5% 200VDC CER 0±30	28480	0160-3875
A37C12	0160-0574	3		CAPACITOR-FXD 022UF ±20% 100VDC CER	28480	0160-0574
A37C13	0180-2207	5	1	CAPACITOR-FXD 100UF ±10% 10VDC TA	56289	150D107X9010R2
A37CR1	1901-0040	1	2	DIODE-SWITCHING 30V 50MA 2NS DO-35	28480	1901-0040
A37CR2	1901-0040	1		DIODE-SWITCHING 30V 50MA 2NS DO-35	28480	1901-0040
A37DS1	1990-0485	5	1	LED-LAMP LUM-INT=800UCD IF=30MA-MAX	28480	5082-4984
A37J1	1250-0690	6	1	CONNECTOR-RF MALE SMB	28480	1250-0690
A37L1	9100-2255	4	1	INDUCTOR RF-CH-MLD 470NH 10% .105DX 26LG	28480	9100-2255
A37L2	9100-1788	6	1	CHOKE-WIDE BAND ZMAX=680 OHM@ 180 MHZ	02114	VK200 20/48
A37MP1	0520-0128	7	2	SCREW-MACH 2-56 25-IN-LG PAN-HD-POZI	00000	ORDER BY DESCRIPTION
A37MP2	0520-0128	7		SCREW-MACH 2-56 25-IN-LG PAN-HD-POZI	00000	ORDER BY DESCRIPTION
A37MP3	0590-0533	5	2	THREADED INSERT-NUT 2-56 06-IN-LG SST	28480	0590-0533
A37MP4	0590-0533	5		THREADED INSERT-NUT 2-56 06-IN-LG SST	28480	0590-0533
A37MP5	1205-0285	0	1	HEAT SINK SGL DIP	28480	1205-0285
A37MP6	2190-0014	1	2	WASHER-LK INTL T NO. 2 089-IN-ID	28480	2190-0014
A37MP7	2190-0014	1		WASHER-LK INTL T NO. 2 089-IN-ID	28480	2190-0014
A37MP8	2190-0124	4	4	WASHER-LK INTL T NO. 10 195-IN-ID	28480	2190-0124
A37MP9	2190-0124	4		WASHER-LK INTL T NO. 10 195-IN-ID	28480	2190-0124
A37MP10	2190-0124	4		WASHER-LK INTL T NO. 10 195-IN-ID	28480	2190-0124
A37MP11	2190-0124	4		WASHER-LK INTL T NO. 10 195-IN-ID	28480	2190-0124
A37MP12	2200-0101	0	2	SCREW-MACH 4-40 188-IN-LG PAN-HD-POZI	00000	ORDER BY DESCRIPTION
A37MP13	2200-0101	0		SCREW-MACH 4-40 188-IN-LG PAN-HD-POZI	00000	ORDER BY DESCRIPTION
A37MP14	2950-0078	9	2	NUT-HEX-DBL-CHAM 10-32-THD 067-IN-THK	28480	2950-0078
A37MP15	2950-0078	9		NUT-HEX-DBL-CHAM 10-32-THD 067-IN-THK	28480	2950-0078
A37MP16	08340-20083	4	1	COVER-PC PLL1 DIVIDER	28480	08340-20083
A37MP17	85660-00012	6	1	HEAT SINK-BOTTOM	28480	85660-00012
A37MP18	85660-20068	4	2	GROUND LUG	28480	85660-20068
A37MP19	85660-20068	4		GROUND LUG	28480	85660-20068
A37MP20	86701-40001	9	2	EXTRACTOR-PC BOARD	28480	86701-40001
A37MP21	86701-40001	9		EXTRACTOR-PC BOARD	28480	86701-40001
A37Q1	1853-0405	9	1	TRANSISTOR PNP SI PD=300MW FT=850MHZ	04713	2N4209
A37Q2	1853-0451	5	2	TRANSISTOR PNP 2N3799 SI TO-18 PD=360MW	01295	2N3799
A37Q3	1853-0451	5		TRANSISTOR PNP 2N3799 SI TO-18 PD=360MW	01295	2N3799
A37R1	0757-0280	3	19	RESISTOR 1K 1% 125W F TC=0±100	24546	C4-1/8-T0-1001-F
A37R2	0698-3431	6	1	RESISTOR 23.7 1% 125W F TC=0±100	03888	PME55-1/8-T0-23R7-F
A37R3	0757-0403	2	2	RESISTOR 121 1% 125W F TC=0±100	24546	C4-1/8-T0-121R-F
A37R4	0757-0280	3		RESISTOR 1K 1% 125W F TC=0±100	24546	C4-1/8-T0-1001-F
A37R5	0757-0280	3		RESISTOR 1K 1% 125W F TC=0±100	24546	C4-1/8-T0-1001-F
A37R6	0757-0394	0	1	RESISTOR 511 1% 125W F TC=0±100	24546	C4-1/8-T0-511R1-F
A37R7	0757-0416	7	5	RESISTOR 511 1% 125W F TC=0±100	24546	C4-1/8-T0-511R-F
A37R8	0757-0416	7		RESISTOR 511 1% 125W F TC=0±100	24546	C4-1/8-T0-511R-F
A37R9	0698-0083	8	1	RESISTOR 1.96K 1% 125W F TC=0±100	24546	C4-1/8-T0-1961-F
A37R10	0698-3440	7	4	RESISTOR 196 1% 125W F TC=0±100	24546	C4-1/8-T0-196R-F
A37R11	0757-0280	3		RESISTOR 1K 1% 125W F TC=0±100	24546	C4-1/8-T0-1001-F
A37R12	0757-0416	7		RESISTOR 511 1% 125W F TC=0±100	24546	C4-1/8-T0-511R-F
A37R13	0757-0416	7		RESISTOR 511 1% 125W F TC=0±100	24546	C4-1/8-T0-511R-F
A37R14	0698-3440	7		RESISTOR 196 1% 125W F TC=0±100	24546	C4-1/8-T0-196R-F
A37R15	0757-0442	9	1	RESISTOR 10K 1% 125W F TC=0±100	24546	C4-1/8-T0-1002-F
A37R16	0757-0280	3		RESISTOR 1K 1% 125W F TC=0±100	24546	C4-1/8-T0-1001-F
A37R17	0698-3440	7		RESISTOR 196 1% 125W F TC=0±100	24546	C4-1/8-T0-196R-F
A37R18	0757-0280	3		RESISTOR 1K 1% 125W F TC=0±100	24546	C4-1/8-T0-1001-F
A37R19	0757-0280	3		RESISTOR 1K 1% 125W F TC=0±100	24546	C4-1/8-T0-1001-F
A37R20	0757-0280	3		RESISTOR 1K 1% 125W F TC=0±100	24546	C4-1/8-T0-1001-F

A37 PLL1 Divider Component-Level Troubleshooting

Table A37-2. A37 PLL1 Divider Replaceable Parts

Reference Designation	HP Part Number	C D	Qty	Description	Mfr Code	Mfr Part Number
A37R21	0757-0280	3		RESISTOR 1K 1% 125W F TC=0±100	24546	C4-1/8-T0-1001-F
A37R22	0757-0280	3		RESISTOR 1K 1% 125W F TC=0±100	24546	C4-1/8-T0-1001-F
A37R23	0757-0280	3		RESISTOR 1K 1% 125W F TC=0±100	24546	C4-1/8-T0-1001-F
A37R24	0757-0280	3		RESISTOR 1K 1% 125W F TC=0±100	24546	C4-1/8-T0-1001-F
A37R25	0757-0280	3		RESISTOR 1K 1% 125W F TC=0±100	24546	C4-1/8-T0-1001-F
A37R26	0757-0280	3		RESISTOR 1K 1% 125W F TC=0±100	24546	C4-1/8-T0-1001-F
A37R27	0757-0280	3		RESISTOR 1K 1% 125W F TC=0±100	24546	C4-1/8-T0-1001-F
A37R28	0757-0280	3		RESISTOR 1K 1% 125W F TC=0±100	24546	C4-1/8-T0-1001-F
A37R29	0757-0280	3		RESISTOR 1K 1% 125W F TC=0±100	24546	C4-1/8-T0-1001-F
A37R30	0757-0418	7		RESISTOR 511 1% 125W F TC=0±100	24546	C4-1/8-T0-511R-F
A37R31	0698-3440	7		RESISTOR 196 1% 125W F TC=0±100	24546	C4-1/8-T0-196R-F
A37R32	0757-0403	2		RESISTOR 121 1% 125W F TC=0±100	24546	C4-1/8-T0-121R-F
A37R33	0757-0419	0	1	RESISTOR 681 1% 125W F TC=0±100	24546	C4-1/8-T0-681R-F
A37R34	0757-0280	3		RESISTOR 1K 1% 125W F TC=0±100	24546	C4-1/8-T0-1001-F
A37R35	0757-0280	3		RESISTOR 1K 1% 125W F TC=0±100	24546	C4-1/8-T0-1001-F
A37TP1	0360-0535	0	14	TERMINAL TEST POINT PCB	00000	ORDER BY DESCRIPTION
A37TP2	0360-0535	0		TERMINAL TEST POINT PCB	00000	ORDER BY DESCRIPTION
A37TP3	0360-0535	0		TERMINAL TEST POINT PCB	00000	ORDER BY DESCRIPTION
A37TP4	0360-0535	0		TERMINAL TEST POINT PCB	00000	ORDER BY DESCRIPTION
A37TP5	0360-0535	0		TERMINAL TEST POINT PCB	00000	ORDER BY DESCRIPTION
A37TP6	0360-0535	0		TERMINAL TEST POINT PCB	00000	ORDER BY DESCRIPTION
A37TP7	0360-0535	0		TERMINAL TEST POINT PCB	00000	ORDER BY DESCRIPTION
A37TP8	0360-0535	0		TERMINAL TEST POINT PCB	00000	ORDER BY DESCRIPTION
A37TP9	0360-0535	0		TERMINAL TEST POINT PCB	00000	ORDER BY DESCRIPTION
A37TP10	0360-0535	0		TERMINAL TEST POINT PCB	00000	ORDER BY DESCRIPTION
A37TP11	0360-0535	0		TERMINAL TEST POINT PCB	00000	ORDER BY DESCRIPTION
A37TP12	0360-0535	0		TERMINAL TEST POINT PCB	00000	ORDER BY DESCRIPTION
A37TP13	0360-0535	0		TERMINAL TEST POINT PCB	00000	ORDER BY DESCRIPTION
A37TP14	0360-0535	0		TERMINAL TEST POINT PCB	00000	ORDER BY DESCRIPTION
A37U1	1820-0909	9	2	IC MULTR TTL	01295	SN74167N
A37U2	1820-0909	9		IC MULTR TTL	01295	SN74167N
A37U3	1820-0808	7	1	IC GATE ECL NOR DUAL 3-INP	04713	MC10111P
A37U4	1820-1225	4	1	IC FF ECL D-M/S DUAL	04713	MC10231P
A37U5	1820-1320	0	1	IC RCVR ECL LINE RCVR TPL 2-INP	04713	MC10216L
A37U6	1810-0204	6	4	NETWORK-RES 8-SIP1 0K OHM X 7	01121	208A102
A37U7	1820-0802	1	1	IC GATE ECL NOR QUAD 2-INP	04713	MC10102P
A37U8	1810-0204	6		NETWORK-RES 8-SIP1 0K OHM X 7	01121	208A102
A37U9	1820-1196	8	2	IC FF TTL LS D-TYPE POS-EDGE-TRIG COM	01295	SN74LS174N
A37U10	1820-1196	8		IC FF TTL LS D-TYPE POS-EDGE-TRIG COM	01295	SN74LS174N
A37U11	1810-0204	6		NETWORK-RES 8-SIP1 0K OHM X 7	01121	208A102
A37U12	1820-0821	4	1	IC CNTR ECL BIN UP/DOWN SYNCHRO	04713	MC10136L
A37U13	1810-0204	6		NETWORK-RES 8-SIP1 0K OHM X 7	01121	208A102
A37U14	1820-0817	8	3	IC FF ECL D-M/S DUAL	04713	MC10131P
A37U15	1820-0817	8		IC FF ECL D-M/S DUAL	04713	MC10131P
A37U16	1820-0817	8		IC FF ECL D-M/S DUAL	04713	MC10131P
A37VR1	1902-3059	0	1	DIODE-ZNR 3.63V 5% DO-35 PD= 4W	28480	1902-3059
A37W1	08340-80107	7	1	CABLE ASSEMBLY-A37	28480	08340-80107

A38 Phase Lock Loop 1 IF Circuit Description

ASSEMBLY PURPOSE

The A38 PLL1 IF mixes the output of the A39 PLL3 up converter (160.15 to 166 MHz) with the LO output from the A36 PLL1 VCO (200 to 300 MHz). The output of this assembly is the difference frequency, which is filtered and amplified to about -10 dBm.

LO AMPLIFIER (BLOCK A)

The LO amplifier consists of two common-emitter amplifiers. The two diodes on the base of Q2 prevent Q1 from overdriving Q2.

MIXER (BLOCK B)

The double-balanced mixer operates with approximately $+7$ dBm LO drive and with approximately -30 dBm RF signal input. The IF output is approximately -36 dBm and is between 30 and 140 MHz. The 185 MHz low-pass filter attenuates the harmonics of the RF signal input. The 10 dB pad reduces the RF signal input from approximately -20 dBm to approximately -30 dBm.

IF INPUT AMPLIFIER (BLOCK C)

The IF input amplifier has an input filter that partially filters the RF and LO signals from the mixer. The filter is followed by a common emitter amplifier.

IF OUTPUT AMPLIFIER (BLOCK D)

The IF output amplifier consists of two common emitter stages and a low-pass filter. The two stages are coupled by C14 and L17 which provide high frequency peaking.

140 MHZ LOW-PASS FILTER (BLOCK E)

The 140 MHz low-pass filter passes 140 MHz while attenuating 160 to 166 MHz signals by at least 60 dB. The three adjustable coils optimize the stop band by providing nulls at the frequencies shown on the A38 assembly schematic diagram, and filters the LO frequencies (200 to 300 MHz).

A38 PLL1 IF Component-Level Troubleshooting

Table A38-1. A38 PLL1 IF Pin I/O

Pin	Mnemonic	Levels	Source	Destination
1	GND	0V	A62 STAR GND	*F
16	GND	0V	A62 STAR GND	*F
2	GND	0V	A62 STAR GND	*F
17	GND	0V	A62 STAR GND	*F
3	GND	0V	A62 STAR GND	*F
18	GND	0V	A62 STAR GND	*F
4	GND	0V	A62 STAR GND	*F
19	GND	0V	A62 STAR GND	*F
5	GND	0V	A62 STAR GND	*F
20	GND	0V	A62 STAR GND	*F
6	GND	0V	A62 STAR GND	*F
21	GND	0V	A62 STAR GND	*F
7	GND	0V	A62 STAR GND	*F
22	GND	0V	A62 STAR GND	*F
8	GND	0V	A62 STAR GND	*F
23	GND	0V	A62 STAR GND	*F
9	GND	0V	A62 STAR GND	*F
24	GND	0V	A62 STAR GND	*F
10	GND	0V	A62 STAR GND	*F
25	GND	0V	A62 STAR GND	*F
11	GND	0V	A62 STAR GND	*F
26	GND	0V	A62 STAR GND	*F
12	-10V	-10V	XA53P1-12, 13, 31, 32	*THRU A62L8 TO F
27	-10V	-10V	XA53P1-12, 13, 31, 32	*THRU A62L8 TO F
13	+12V U1 ADJ	+10.5V	XA52P1-10	*THRU A62LF TO F
28	+12V UI ADJ	+10.5V	XA52P1-10	*THRU A62LF TO F
14	GND	0V	A62 STAR GND	*F
29	GND	0V	A62 STAR GND	*F
15	GND	0V	A62 STAR GND	*F
30	GND	0V	A62 STAR GND	*F

A single letter in the source or destination column refers to a function block on this assembly schematic.

An asterisk (*) denotes multiple sources or destinations; refer to the A62 motherboard wiring list for a complete representation of signal sources and destinations.

A38 PLL1 IF Component-Level Troubleshooting

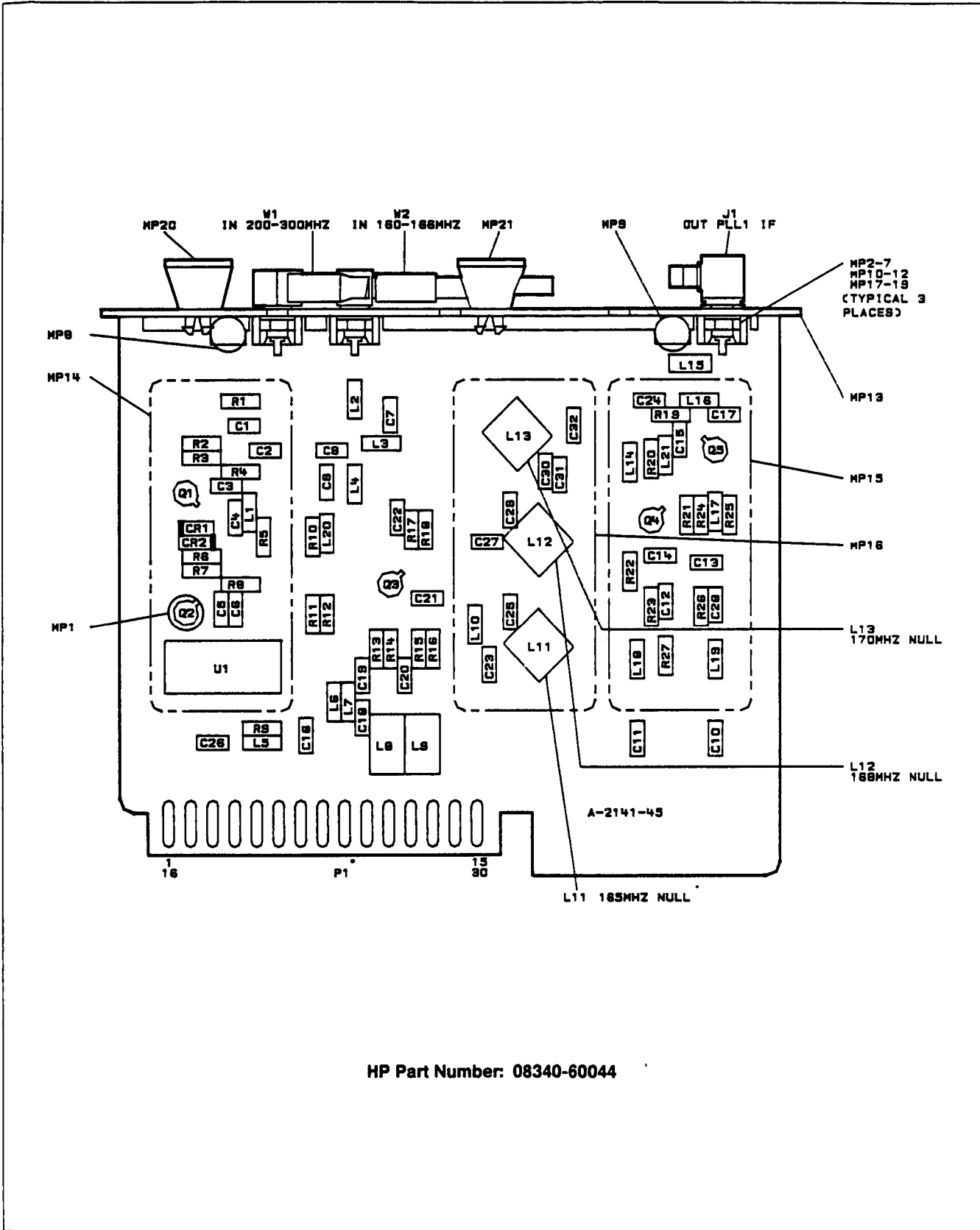

HP Part Number: 08340-60044

Figure A38-1. A38 PLL1 IF Component Location Diagram

A38 PLL1 IF Component-Level Troubleshooting

Table A38-2. A38 PLL1 IF Replaceable Parts

Reference Designation	HP Part Number	C D	Qty	Description	Mfr Code	Mfr Part Number
A38	08340-60044	1	1	PLL1 IF ASSEMBLY	28480	08340-60044
A38C1	0160-3878	6	5	CAPACITOR-FXD 1000PF ± 20% 100VDC CER	28480	0160-3878
A38C2	0160-0574	3	12	CAPACITOR-FXD 022UF ± 20% 100VDC CER	28480	0160-0574
A38C3	0160-3878	6		CAPACITOR-FXD 1000PF ± 20% 100VDC CER	28480	0160-3878
A38C4	0160-3878	6		CAPACITOR-FXD 1000PF ± 20% 100VDC CER	28480	0160-3878
A38C5	0160-0574	3		CAPACITOR-FXD 022UF ± 20% 100VDC CER	28480	0160-0574
A38C6	0160-3878	6		CAPACITOR-FXD 1000PF ± 20% 100VDC CER	28480	0160-3878
A38C7	0160-3875	3	4	CAPACITOR-FXD 22PF ± 5% 200VDC CER 0 ± 30	28480	0160-3875
A38C8	0160-3875	3		CAPACITOR-FXD 22PF ± 5% 200VDC CER 0 ± 30	28480	0160-3875
A38C9	0160-3875	3		CAPACITOR-FXD 22PF ± 5% 200VDC CER 0 ± 30	28480	0160-3875
A38C10	0160-0574	3		CAPACITOR-FXD 022UF ± 20% 100VDC CER	28480	0160-0574
A38C11	0160-0574	3		CAPACITOR-FXD 022UF ± 20% 100VDC CER	28480	0160-0574
A38C12	0160-0574	3		CAPACITOR-FXD 022UF ± 20% 100VDC CER	28480	0160-0574
A38C13	0160-0574	3		CAPACITOR-FXD 022UF ± 20% 100VDC CER	28480	0160-0574
A38C14	0160-3876	4	1	CAPACITOR-FXD 47PF ± 20% 200VDC CER	28480	0160-3876
A38C15	0160-0574	3		CAPACITOR-FXD 022UF ± 20% 100VDC CER	28480	0160-0574
A38C16	0160-3653	5	1	CAPACITOR-FXD 33PF ± 5% 200VDC CER 0 ± 30	28480	0160-3653
A38C17	0160-3878	6		CAPACITOR-FXD 1000PF ± 20% 100VDC CER	28480	0160-3878
A38C18	0160-3874	2		CAPACITOR-FXD 10PF ± 5PF 200VDC CER	28480	0160-3874
A38C19	0160-0574	3		CAPACITOR-FXD 022UF ± 20% 100VDC CER	28480	0160-0574
A38C20	0160-0574	3		CAPACITOR-FXD 022UF ± 20% 100VDC CER	28480	0160-0574
A38C21	0160-0574	3		CAPACITOR-FXD 022UF ± 20% 100VDC CER	28480	0160-0574
A38C22	0160-0574	3		CAPACITOR-FXD 022UF ± 20% 100VDC CER	28480	0160-0574
A38C23	0160-3874	2		CAPACITOR-FXD 10PF ± 5PF 200VDC CER	28480	0160-3874
A38C24	0160-3875	3		CAPACITOR-FXD 22PF ± 5% 200VDC CER 0 ± 30	28480	0160-3875
A38C25	0160-3565	8	3	CAPACITOR-FXD 6.8PF ± 5PF 100VDC CER	28480	0160-3565
A38C26*	0160-3874	2	4	CAPACITOR-FXD 10PF ± 5PF 200VDC CER	28480	0160-3874
A38C27	0160-3565	8		CAPACITOR-FXD 6.8PF ± 5PF 100VDC CER	28480	0160-3565
A38C28	0160-0574	3		CAPACITOR-FXD 022UF ± 20% 100VDC CER	28480	0160-0574
A38C29	0160-3874	2		CAPACITOR-FXD 10PF ± 5PF 200VDC CER	28480	0160-3874
A38C30	0160-3565	8		CAPACITOR-FXD 6.8PF ± 5PF 100VDC CER	28480	0160-3565
A38C31	0160-3873	1	1	CAPACITOR-FXD 4.7PF ± 5PF 200VDC CER	28480	0160-3873
A38C32	0160-4289	5	1	CAPACITOR-FXD 15PF ± 5% 100VDC CER 0 ± 30	51642	150100COG150J
A38CR1	1901-0535	9	2	DIODE-SM SIG SCHOTTKY	28480	1901-0535
A38CR2	1901-0535	9		DIODE-SM SIG SCHOTTKY	28480	1901-0535
A38J1	1250-0690	6	1	CONNECTOR-RF MALE SMB	28480	1250-0690
A38L1	9100-2256	5	3	INDUCTOR RF-CH-MLD 560NH 10% 105DX 26LG	28480	9100-2256
A38L2	9100-2247	4	5	INDUCTOR RF-CH-MLD 100NH 10% 105DX 26LG	28480	9100-2247
A38L3	9100-2248	5	3	INDUCTOR RF-CH-MLD 120NH 10% 105DX 26LG	28480	9100-2248
A38L4	9100-2248	5		INDUCTOR RF-CH-MLD 120NH 10% 105DX 26LG	28480	9100-2248
A38L5	9100-2891	4	3	INDUCTOR RF-CH-MLD 50NH 10% 105DX 26LG	28480	9100-2891
A38L6	9100-2247	4		INDUCTOR RF-CH-MLD 100NH 10% 105DX 26LG	28480	9100-2247
A38L7	9100-2247	4		INDUCTOR RF-CH-MLD 100NH 10% 105DX 26LG	28480	9100-2247
A38L8	9100-1788	6	2	CHOKE-WIDE BAND ZMAX = 680 OHM@ 180 MHZ	02114	VK200 20/48
A38L9	9100-1788	6		CHOKE-WIDE BAND ZMAX = 680 OHM@ 180 MHZ	02114	VK200 20/48
A38L10	9100-0368	6	1	INDUCTOR RF-CH-MLD 330NH 10% 105DX 26LG	28480	9100-0368
A38L11	85660-80006	6	2	INDUCTOR- 120 NH	28480	85660-80006
A38L12	85660-80009	9	1	INDUCTOR- 100 NH	28480	85660-80009
A38L13	85660-80006	6		INDUCTOR- 120 NH	28480	85660-80006
A38L14	9100-2251	0	1	INDUCTOR RF-CH-MLD 220NH 10% 105DX 26LG	28480	9100-2251
A38L15	9100-2247	4		INDUCTOR RF-CH-MLD 100NH 10% 105DX 26LG	28480	9100-2247
A38L16	9100-2247	4		INDUCTOR RF-CH-MLD 100NH 10% 105DX 26LG	28480	9100-2247
A38L17	9100-2248	5		INDUCTOR RF-CH-MLD 120NH 10% 105DX 26LG	28480	9100-2248
A38L18	9100-2256	5		INDUCTOR RF-CH-MLD 560NH 10% 105DX 26LG	28480	9100-2256
A38L19	9100-2256	5		INDUCTOR RF-CH-MLD 560NH 10% 105DX 26LG	28480	9100-2256
A38L20	9100-2891	4		INDUCTOR RF-CH-MLD 50NH 10% 105DX 26LG	28480	9100-2891
A38L21	9100-2891	4		INDUCTOR RF-CH-MLD 50NH 10% 105DX 26LG	28480	9100-2891
A38MP1				NOT ASSIGNED		
A38MP2	2190-0124	4	6	WASHER-LK INTL T NO 10 195-IN-ID	28480	2190-0124
A38MP3	2190-0124	4		WASHER-LK INTL T NO 10 195-IN-ID	28480	2190-0124
A38MP4	2190-0124	4		WASHER-LK INTL T NO 10 195-IN-ID	28480	2190-0124
A38MP5	2190-0124	4		WASHER-LK INTL T NO 10 195-IN-ID	28480	2190-0124
A38MP6	2190-0124	4		WASHER-LK INTL T NO 10 195-IN-ID	28480	2190-0124
A38MP7	2190-0124	4		WASHER-LK INTL T NO 10 195-IN-ID	28480	2190-0124
A38MP8	2200-0101	0	2	SCREW-MACH 4-40 188-IN-LG PAN-HD-POZI	00000	ORDER BY DESCRIPTION
A38MP9	2200-0101	0		SCREW-MACH 4-40 188-IN-LG PAN-HD-POZI	00000	ORDER BY DESCRIPTION
A38MP10	2950-0078	9	3	NUT-HEX-DBL-CHAM 10-32-THD 067-IN-THK	28480	2950-0078

A38 PLL1 IF Component-Level Troubleshooting

Table A38-2. A38 PLL1 IF Replaceable Parts

Reference Designation	HP Part Number	C D	Qty	Description	Mfr Code	Mfr Part Number
A38MP11	2950-0078	9		NUT-HEX-DBL-CHAM 10-32-THD .067-IN-THK	28480	2950-0078
A38MP12	2950-0078	9		NUT-HEX-DBL-CHAM 10-32-THD .067-IN-THK	28480	2950-0078
A38MP13	08340-20084	5	1	COVER-PC PLL1 IF	28480	08340-20084
A38MP14	85660-00038	6	2	SHIELDING CAN	28480	85660-00038
A38MP15	85660-00038	6		SHIELDING CAN	28480	85660-00038
A38MP16	85660-00040	0	1	SHIELDING CAN	28480	85660-00040
A38MP17	85660-20068	4	3	GROUND LUG	28480	85660-20068
A38MP18	85660-20068	4		GROUND LUG	28480	85660-20068
A38MP19	85660-20068	4		GROUND LUG	28480	85660-20068
A38MP20	86701-40001	9	2	EXTRACTOR-PC BOARD	28480	86701-40001
A38MP21	86701-40001	9		EXTRACTOR-PC BOARD	28480	86701-40001
A38Q1	1854-0345	8	4	TRANSISTOR NPN 2N5179 SI TO-72 PD=200MW	04713	2N5179
A38Q2	1854-0378	7	1	TRANSISTOR NPN 2N5109 SI TO-39 PD=800MW	3L585	2N5109
A38Q3	1854-0345	8		TRANSISTOR NPN 2N5179 SI TO-72 PD=200MW	04713	2N5179
A38Q4	1854-0345	8		TRANSISTOR NPN 2N5179 SI TO-72 PD=200MW	04713	2N5179
A38Q5	1854-0345	8		TRANSISTOR NPN 2N5179 SI TO-72 PD=200MW	04713	2N5179
A38R1	0757-0394	0	3	RESISTOR 51.1 1% .125W F TC=0±100	24546	C4-1/8-T0-51R1-F
A38R2	0698-3152	8	2	RESISTOR 3.48K 1% .125W F TC=0±100	24546	C4-1/8-T0-3481-F
A38R3	0757-0421	4	1	RESISTOR 825 1% .125W F TC=0±100	24546	C4-1/8-T0-825R-F
A38R4	0757-0401	0	3	RESISTOR 100 1% .125W F TC=0±100	24546	C4-1/8-T0-101-F
A38R5	0698-3429	2	3	RESISTOR 19.6 1% .125W F TC=0±100	03888	PME55-1/8-T0-19R6-F
A38R6	0698-3438	3	1	RESISTOR 147 1% .125W F TC=0±100	24546	C4-1/8-T0-147R-F
A38R7	0698-3448	3	1	RESISTOR 383 1% .125W F TC=0±100	24546	C4-1/8-T0-383R-F
A38R8	0698-3440	7	2	RESISTOR 196 1% .125W F TC=0±100	24546	C4-1/8-T0-196R-F
A38R9	0757-0394	0		RESISTOR 51.1 1% .125W F TC=0±100	24546	C4-1/8-T0-51R1-F
A38R10	0757-0401	0		RESISTOR 100 1% .125W F TC=0±100	24546	C4-1/8-T0-101-F
A38R11	0757-0397	3	1	RESISTOR 88.1 1% .125W F TC=0±100	24546	C4-1/8-T0-88R1-F
A38R12	0757-0401	0		RESISTOR 100 1% .125W F TC=0±100	24546	C4-1/8-T0-101-F
A38R13	0757-0428	1	1	RESISTOR 1.62K 1% .125W F TC=0±100	24546	C4-1/8-T0-1621-F
A38R14	0698-3152	8		RESISTOR 3.48K 1% .125W F TC=0±100	24546	C4-1/8-T0-3481-F
A38R15	0757-0416	7	1	RESISTOR 511 1% .125W F TC=0±100	24546	C4-1/8-T0-511R-F
A38R16	0698-3444	1	2	RESISTOR 316 1% .125W F TC=0±100	24546	C4-1/8-T0-316R-F
A38R17	0757-0346	2	1	RESISTOR 10 1% .125W F TC=0±100	24546	C4-1/8-T0-10R0-F
A38R18	0698-3444	1		RESISTOR 316 1% .125W F TC=0±100	24546	C4-1/8-T0-316R-F
A38R19	0757-0394	0		RESISTOR 51.1 1% .125W F TC=0±100	24546	C4-1/8-T0-51R1-F
A38R20	0698-3429	2		RESISTOR 19.6 1% .125W F TC=0±100	03888	PME55-1/8-T0-19R6-F
A38R21	0757-0280	3	5	RESISTOR 1K 1% .125W F TC=0±100	24546	C4-1/8-T0-1001-F
A38R22	0757-0280	3		RESISTOR 1K 1% .125W F TC=0±100	24546	C4-1/8-T0-1001-F
A38R23	0757-0280	3		RESISTOR 1K 1% .125W F TC=0±100	24546	C4-1/8-T0-1001-F
A38R24	0698-3429	2		RESISTOR 19.6 1% .125W F TC=0±100	03888	PME55-1/8-T0-19R6-F
A38R25	0757-0280	3		RESISTOR 1K 1% .125W F TC=0±100	24546	C4-1/8-T0-1001-F
A38R26	0757-0280	3		RESISTOR 1K 1% .125W F TC=0±100	24546	C4-1/8-T0-1001-F
A38R27	0698-3440	7		RESISTOR 196 1% .125W F TC=0±100	24546	C4-1/8-T0-196R-F
A38U1	0955-0063	0	1	MIXER-DOUBLER 5-500 MH	28480	0955-0063
A38W1	08340-60108	8	1	CABLE ASSEMBLY-A38	28480	08340-60108
A38W2	08340-60113	5	1	CABLE ASSEMBLY-A38	28480	08340-60113

A39 Phase Lock Loop 3 Upconverter Circuit Description

ASSEMBLY PURPOSE

The A39 PLL3 upconverter changes the 0.15 to 6 MHz output of the A40 PLL2 VCO to a signal between 160.15 to 166 MHz. The 160.15 to 166 MHz signal is required by the A38 PLL1 IF mixer.

The A39 assembly uses two input signals:

- 100 MHz signal from the A30 100 MHz VCXO
- 0.15 to 6 MHz signal from the A40 PLL2 VCO

The 100 MHz signal is multiplied by a factor of 1.6 and mixed with the A39 assembly's internal VCO signal from block D. The mixer produces an IF signal that ranges from 0.15 to 6 MHz. This signal is phase/frequency compared to the output of the A40 PLL2 VCO, which is also 0.15 to 6 MHz.

The phase/frequency detector converts any phase/frequency difference into an error voltage that tunes the A39 assembly's internal VCO, forming a phase lock loop (PLL3) with a bandwidth of approximately 10 kHz.

FREQUENCY MULTIPLIER (X 1.6) (BLOCK A)

This circuit divides the 100 MHz output of the A30 100 MHz VCXO by five, and selects the eighth harmonic of the divided signal.

ECL counter U3 is connected so that its output inhibits one output pulse for every five input pulses. Refer to the waveforms in Figure A39-1.

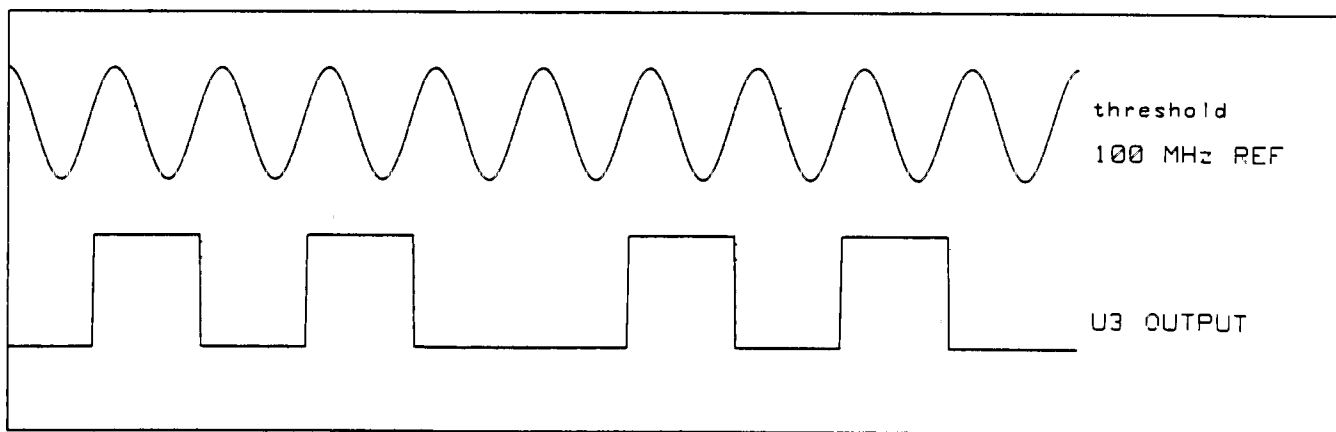

Figure A39-1. A39 PLL3 Frequency Multiplier Waveforms.

Inhibiting a pulse allows this circuit to produce a double narrow pulse (refer to U3 output in figure A39-1) at a 20 MHz rate.

The 160 MHz bandpass filter selects the eighth harmonic of the 20 MHz signal mentioned above (160 MHz). This 160 MHz signal is amplified. The amplifier stage contains a tank circuit tuned to 160 MHz. The tank circuit rejects unwanted frequencies.

The final stage is a 5 dB attenuator which reduces distortion in the following mixer (block B) and improves the 50 Ω impedance match to the mixer input.

MIXER (BLOCK B)

The double-balanced mixer operates with an RF input of 160 MHz at approximately -20 dBm, and an LO input of 160.15 to 166 MHz at approximately $+7$ dBm.

IF AMPLIFIER (BLOCK C)

The IF output of the mixer (block B) is filtered by a 10 MHz low pass filter which rejects frequencies above 14 MHz. The IF signal is then amplified by the transistor circuit.

160 TO 166 MHZ VCO (Voltage Controlled Oscillator) (BLOCK D)

An adjustable tank circuit tunes in the desired VCO center frequency and rejects unwanted frequencies. The center frequency of the VCO signal is changed with a variable inductor (VCO Center Frequency Adjust).

A common-emitter amplifier buffers the output of the VCO (block D) and drives the mixer's LO port (shown in block B). A common-base buffer amplifier provides the 160-166 MHz output to the A38 PLL1 IF via connector A39J1.

PHASE/FREQUENCY DETECTOR (BLOCK E)

The phase/frequency detector generates a differential output signal used by the loop amplifier (block F) and the phase lock indicator (block G). The main components of the phase/frequency detector are two ECL flip-flops and three ECL NOR gates.

The two input signals go to ECL NOR gates U6B and U6C, which generate ECL level inputs for the following flip flops (frequency to ECL translation).

The SET inputs to both flip-flops are tied together and driven by the output of U6A. When the non-inverted outputs of the flip-flops are both low, the SET lines on both flip-flops are triggered and the non-inverted outputs of the flip-flops go high.

As shown in Figure A39-2, when one of the clock inputs goes high, the corresponding noninverting output goes low (and remains low). When the other clock input goes high, the other noninverting input goes low. When both noninverting outputs are low, the SET inputs are triggered and both noninverting outputs go high until the next clock pulse is received.

When the inputs are out of phase, the noninverting outputs become different. The noninverting output with the longer negative going pulse corresponds to the leading input. When the inputs are locked together, the noninverting outputs are both high, with low narrow pulses coincident with the input rising edge.

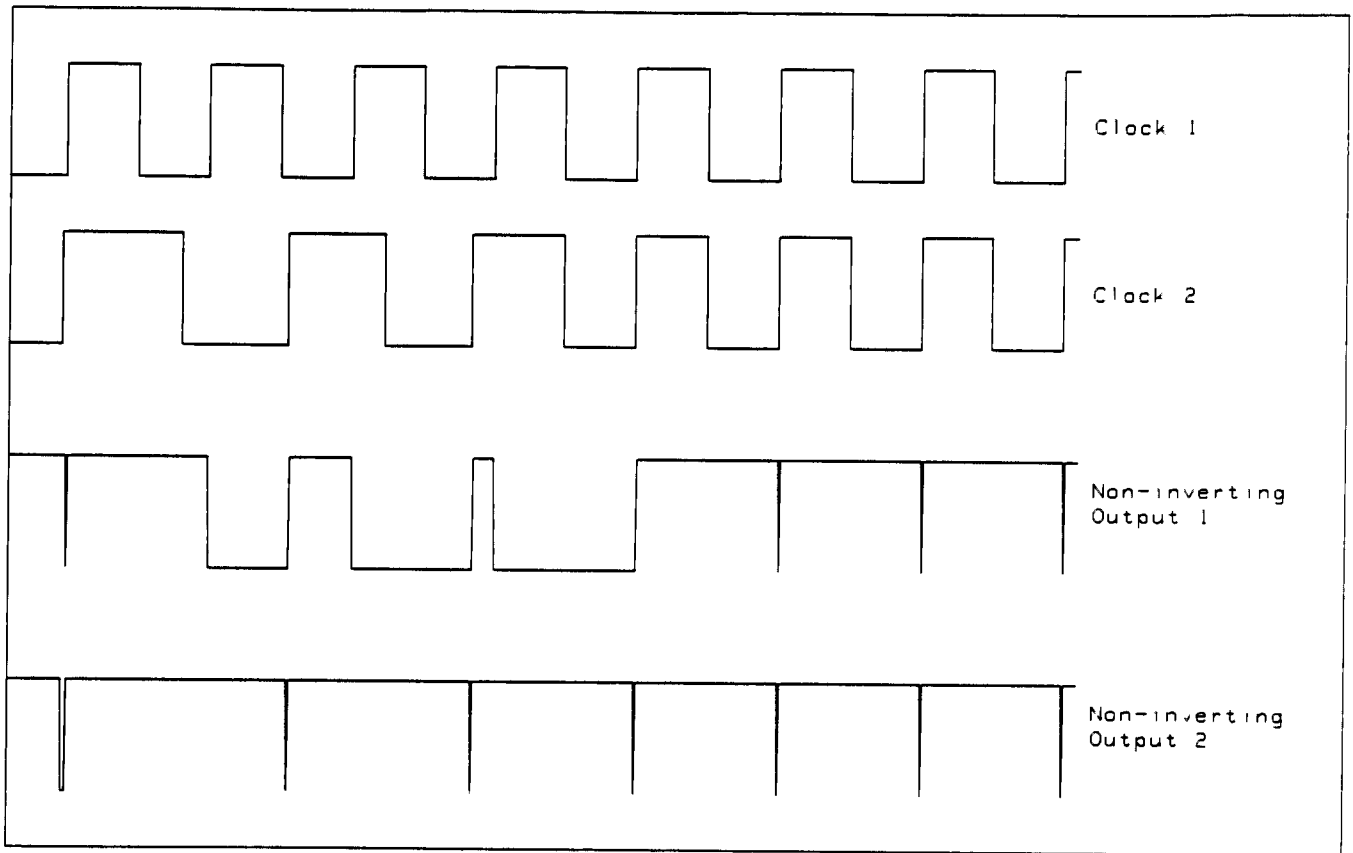

Figure A39-2. A39 PLL3 Phase/Frequency Detector Waveforms

LOOP AMPLIFIER (BLOCK F)

The inputs to the loop amplifier are the phase detector differential outputs. Each differential input passes through identical low-pass filters (R5, R9, C2, R6, R10, and C3). C9, R16, C8, and R17 provide a large DC gain for the loop amplifier. These components also provide the same input impedance to each of the differential amplifier's inputs. R14, R15 and C7 form an AC voltage divider that sets the loop bandwidth to about 10 KHz, and limits the noise introduced by U2.

The output of the divider goes to the varactor diode (in block D) to tune the VCO.

R18, CR4 and CR5 reduce the charging time of C7 when the frequency is abruptly changed.

If the VCO is tuned to a frequency lower than the 160 MHz reference frequency (block A), the mixer output frequency still equals the difference of the two input frequencies, but the loop provides positive feedback rather than negative feedback. Positive feedback drives the VCO to the low end of its frequency range. U1B prevents the VCO tune voltage from latching at a positive value by sensing when the voltage goes above 0 volts. When this occurs, the output of U1B pulls the tune voltage down to the proper lock range.

R13 provides hysteresis, allowing time for the loop to lock. CR2 prevents the output of U1B from interfering with the VCO.

PHASE LOCK INDICATOR (BLOCK G)

The phase lock indicator senses the outputs of the phase detector to determine when the loop is locked. The noninverting outputs of the phase detector flip-flops are attenuated by R23 and summed into the inverting input of U1A. The inverted outputs of the flip-flops are tied together (wire-or) and input to the noninverting input of U1A. C1 filters out the high frequency components of the flip-flop outputs so the phase lock indicator responds to the average voltages on each input. When the inverting input of U1A is more positive than the noninverting input, the indicator shows a phase locked condition by lighting DS1 and setting HUL1 TTL low.

A39 PLL3 Upconverter Component-Level Troubleshooting

Table A39-1. A39 PLL3 Upconverter Pin I/O

Pin	Mnemonic	Levels	Source	Destination
1 16	HUL1 HUL1	TTL (HIGH TRUE) TTL (HIGH TRUE)	*G *G	XA59P1-106 XA59P1-106
2 17	GND GND	0V 0V	A62 STAR GND A62 STAR GND	*H *H
3 18	GND GND	0V 0V	A62 STAR GND A62 STAR GND	*H *H
4 19	GND GND	0V 0V	A62 STAR GND A62 STAR GND	*H *H
5 20	GND GND	0V 0V	A62 STAR GND A62 STAR GND	*H *H
6 21	GND GND	0V 0V	A62 STAR GND A62 STAR GND	*H *H
7 22	GND GND	0V 0V	A62 STAR GND A62 STAR GND	*H *H
8 23	GND GND	0V 0V	A62 STAR GND A62 STAR GND	*H *H
9 24	GND GND	0V 0V	A62 STAR GND A62 STAR GND	*H *H
10 25	GND GND	0V 0V	A62 STAR GND A62 STAR GND	*H *H
11 26	GND GND	0V 0V	A62 STAR GND A62 STAR GND	*H *H
12 27	-10V -10V	-10V -10V	XA53P1-12, 13, 31, 32 XA53P1-12, 13, 31, 32	*THRU A62L4 TO H *THRU A62L4 TO H
13 28	GND GND	0V 0V	A62 STAR GND A62 STAR GND	*H *H
14 29	GND GND	0V 0V	A62 STAR GND A62 STAR GND	*H *H
15 30	+5.2V +5.2V	+5.2V +5.2V	XA52P1-17, 18, 41, 42 XA52P1-17, 18, 41, 42	*THRU A62L3 TO H *THRU A62L3 TO H

A single letter in the source or destination column refers to a function block on this assembly schematic.

An asterisk (*) denotes multiple sources or destinations; refer to the A62 motherboard wiring list for a complete representation of signal sources and destinations.

A39 PLL3 Upconverter Component-Level Troubleshooting

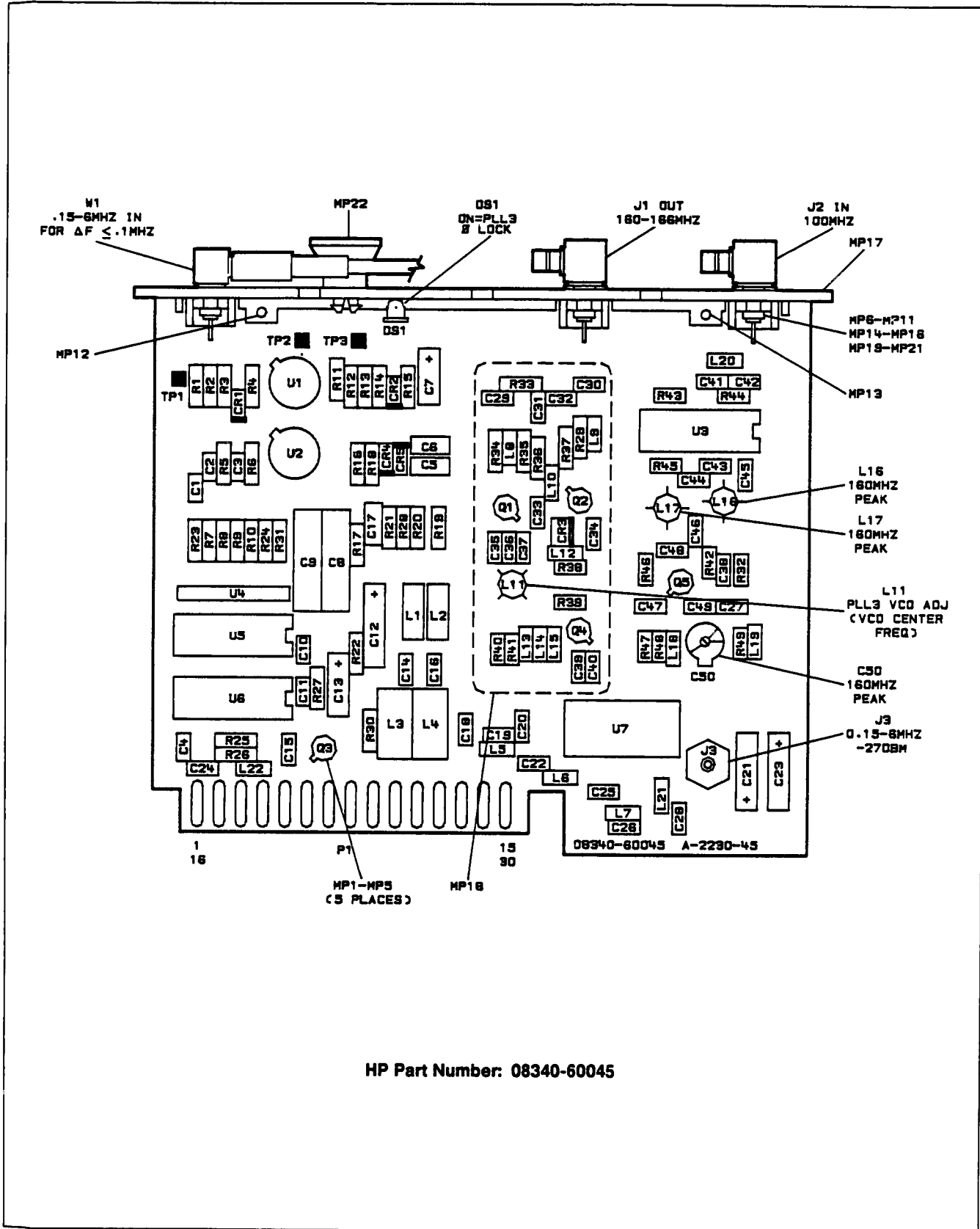

Figure A39-3. A39 PLL3 Upconverter Component Location Diagram

339 PHASE LOCK LOOP 3 (PLL3) UP CONVERTER
 68340-8064

NOTE:
 1. RESISTANCE VALUES SHOWN ARE IN OHMS, CAPACITANCE IN MICROFARADS, AND INDUCTANCE IN MICROHENRIES, UNLESS OTHERWISE NOTED.
 2. J1, J2, AND A3041 CENTER CONDUCTORS OF BOARD THROUGH HOLES ARE ELECTRICALLY ISOLATED FROM BOARD THROUGH MECHANICAL BORE CONNECTIONS IN THE ASSEMBLY COVER PLATE.

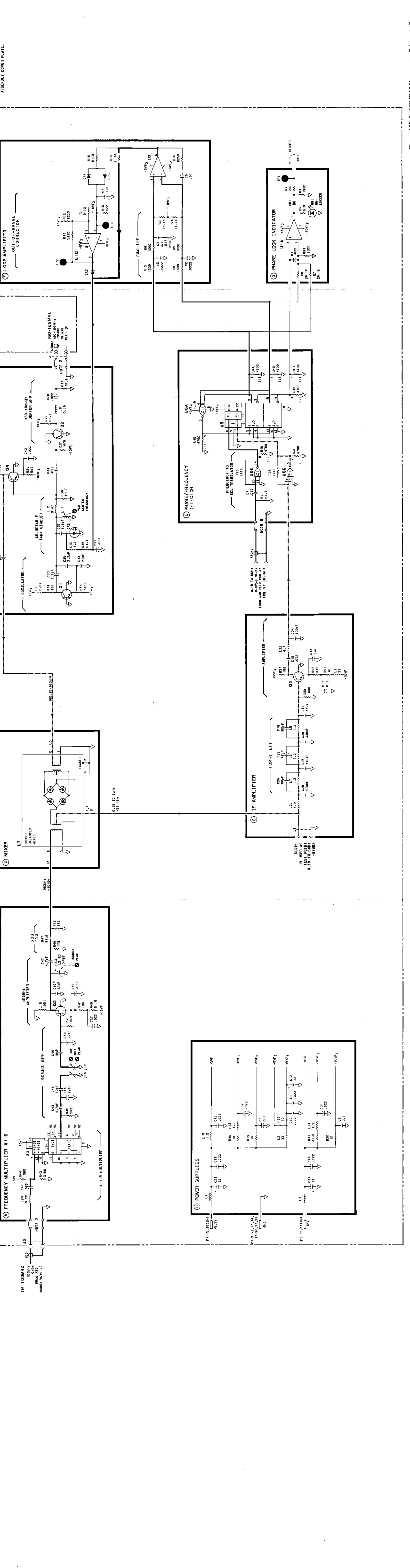

Figure A39-4. A39 PLL3 Upconverter Schematic Diagram
 20/30 Loops A39-7/A39-8

A39 PLL3 Upconverter Component-Level Troubleshooting

Table A39-2. A39 PLL3 Upconverter Replaceable Parts

Reference Designation	HP Part Number	C D	Qty	Description	Mfr Code	Mfr Part Number
A39	08340-60045	2	1	PLL3 UPCONVERTER ASSEMBLY	28480	08340-60045
A39C1	0160-0574	3	16	CAPACITOR-FXD 022UF ± 20% 100VDC CER	28480	0160-0574
A39C2	0160-0572	1	2	CAPACITOR-FXD 2200PF ± 20% 100VDC CER	28480	0160-0572
A39C3	0160-0572	1	2	CAPACITOR-FXD 2200PF ± 20% 100VDC CER	28480	0160-0572
A39C4	0160-0574	3	16	CAPACITOR-FXD 022UF ± 20% 100VDC CER	28480	0160-0574
A39C5	0160-4084	8	3	CAPACITOR-FXD 1UF ± 20% 50VDC CER	28480	0160-4084
A39C6	0160-4084	8	3	CAPACITOR-FXD 1UF ± 20% 50VDC CER	28480	0160-4084
A39C7	0180-0291	3	2	CAPACITOR-FXD 1UF ± 10% 35VDC TA	56289	150D105X9035A2
A39C8	0160-0161	4	2	CAPACITOR-FXD 01UF ± 10% 200VDC POLYE	28480	0160-0161
A39C9	0160-0161	4	2	CAPACITOR-FXD 01UF ± 10% 200VDC POLYE	28480	0160-0161
A39C10	0160-0574	3	16	CAPACITOR-FXD 022UF ± 20% 100VDC CER	28480	0160-0574
A39C11	0160-0574	3	16	CAPACITOR-FXD 022UF ± 20% 100VDC CER	28480	0160-0574
A39C12	0180-0228	6	3	CAPACITOR-FXD 22UF ± 10% 15VDC TA	56289	150D226X9015B2
A39C13	0180-0291	3	2	CAPACITOR-FXD 1UF ± 10% 35VDC TA	56289	150D105X9035A2
A39C14	0160-0574	3	16	CAPACITOR-FXD 022UF ± 20% 100VDC CER	28480	0160-0574
A39C15	0180-0574	3	16	CAPACITOR-FXD 022UF ± 20% 100VDC CER	28480	0160-0574
A39C16	0160-0574	3	16	CAPACITOR-FXD 022UF ± 20% 100VDC CER	28480	0160-0574
A39C17	0160-4084	8	3	CAPACITOR-FXD 1UF ± 20% 50VDC CER	28480	0160-4084
A39C18	0160-3749	0	2	CAPACITOR-FXD 330PF ± 10% 50VDC CER	28480	0160-3749
A39C19	0160-3877	5	3	CAPACITOR-FXD 100PF ± 20% 200VDC CER	28480	0160-3877
A39C20	0160-3749	0	2	CAPACITOR-FXD 330PF ± 10% 50VDC CER	28480	0160-3749
A39C21	0180-0228	6	3	CAPACITOR-FXD 22UF ± 10% 15VDC TA	56289	150D226X9015B2
A39C22	0160-3876	4	1	CAPACITOR-FXD 47PF ± 20% 200VDC CER	28480	0160-3876
A39C23	0180-0228	6	3	CAPACITOR-FXD 22UF ± 10% 15VDC TA	56289	150D226X9015B2
A39C24	0160-3877	5	3	CAPACITOR-FXD 100PF ± 20% 200VDC CER	28480	0160-3877
A39C25	0160-0571	0	2	CAPACITOR-FXD 470PF ± 20% 100VDC CER	28480	0160-0571
A39C26	0160-3877	5	3	CAPACITOR-FXD 100PF ± 20% 200VDC CER	28480	0160-3877
A39C27	0160-0574	3	16	CAPACITOR-FXD 022UF ± 20% 100VDC CER	28480	0160-0574
A39C28	0160-0571	0	2	CAPACITOR-FXD 470PF ± 20% 100VDC CER	28480	0160-0571
A39C29	0160-3878	6	1	CAPACITOR-FXD 1000PF ± 20% 100VDC CER	28480	0160-3878
A39C30	0160-0574	3	16	CAPACITOR-FXD 022UF ± 20% 100VDC CER	28480	0160-0574
A39C31	0160-0574	3	16	CAPACITOR-FXD 022UF ± 20% 100VDC CER	28480	0160-0574
A39C32	0160-0574	3	16	CAPACITOR-FXD 022UF ± 20% 100VDC CER	28480	0160-0574
A39C33	0160-3875	3	3	CAPACITOR-FXD 22PF ± 5% 200VDC CER 0 ± 30	28480	0160-3875
A39C34	0160-0574	3	16	CAPACITOR-FXD 022UF ± 20% 100VDC CER	28480	0160-0574
A39C35	0160-3872	0	2	CAPACITOR-FXD 2 2PF ± 25PF 200VDC CER	28480	0160-3872
A39C36	0160-3872	0	2	CAPACITOR-FXD 2 2PF ± 25PF 200VDC CER	28480	0160-3872
A39C37	0160-3565	8	1	CAPACITOR-FXD 6.8PF ± 5PF 100VDC CER	28480	0160-3565
A39C38	0160-0574	3	16	CAPACITOR-FXD 022UF ± 20% 100VDC CER	28480	0160-0574
A39C39	0160-3874	2	3	CAPACITOR-FXD 10PF ± 5PF 200VDC CER	28480	0160-3874
A39C40	0160-0574	3	16	CAPACITOR-FXD 022UF ± 20% 100VDC CER	28480	0160-0574
A39C41	0160-0574	3	16	CAPACITOR-FXD 022UF ± 20% 100VDC CER	28480	0160-0574
A39C42	0160-0574	3	16	CAPACITOR-FXD 022UF ± 20% 100VDC CER	28480	0160-0574
A39C43	0160-3873	1	2	CAPACITOR-FXD 4 7PF ± 5PF 200VDC CER	28480	0160-3873
A39C44	0160-3875	3	3	CAPACITOR-FXD 22PF ± 5% 200VDC CER 0 ± 30	28480	0160-3875
A39C45	0160-3874	2	3	CAPACITOR-FXD 10PF ± 5PF 200VDC CER	28480	0160-3874
A39C46	0160-3874	2	3	CAPACITOR-FXD 10PF ± 5PF 200VDC CER	28480	0160-3874
A39C47	0160-3873	1	2	CAPACITOR-FXD 4 7PF ± 5PF 200VDC CER	28480	0160-3873
A39C48	0160-3875	3	3	CAPACITOR-FXD 22PF ± 5% 200VDC CER 0 ± 30	28480	0160-3875
A39C49*	0160-4521	8	1	CAPACITOR-FXD 12PF ± 5% 200VDC CER 0 ± 30	28480	0160-4521
A39C50	0121-0452	4	1	CAPACITOR-V TRMR-AIR 1 3-5 4PF 175V	74970	187-0103-028
A39CR1	1901-0050	3	4	DIODE-SWITCHING 80V 200MA 2NS DO-35	28480	1901-0050
A39CR2	1901-0050	3	4	DIODE-SWITCHING 80V 200MA 2NS DO-35	28480	1901-0050
A39CR3	0122-0085	1	1	DIODE-VVC 2 2PF 7% C3/C25-MIN = 4.5	02032	SMV1288
A39CR4	1901-0050	3	4	DIODE-SWITCHING 80V 200MA 2NS DO-35	28480	1901-0050
A39CR5	1901-0050	3	4	DIODE-SWITCHING 80V 200MA 2NS DO-35	28480	1901-0050
A39DS1	1990-0485	5	1	LED-LAMP LUM-INT = 800UCD IF = 30MA-MAX	28480	5082-4984
A39J1	1250-0690	6	2	CONNECTOR-RF MALE SMB	28480	1250-0690
A39J2	1250-0690	6	2	CONNECTOR-RF MALE SMB	28480	1250-0690
A39J3	1250-1889	7	1	CONNECTOR-RF SMB M PC 50-OHM	28480	1250-1889
A39L1	9140-0179	1	2	INDUCTOR RF-CH-MLD 22UH 10% 166DX 385LG	28480	9140-0179
A39L2	9140-0179	1	2	INDUCTOR RF-CH-MLD 22UH 10% 166DX 385LG	28480	9140-0179
A39L3	9100-1788	6	2	CHOKE-WIDE BAND ZMAX = 680 OHM@ 180 MHZ	02114	VK200 20/48
A39L4	9100-1788	6	2	CHOKE-WIDE BAND ZMAX = 680 OHM@ 180 MHZ	02114	VK200 20/48
A39L5	9100-2258	7	7	INDUCTOR RF-CH-MLD 1 2UH 10% 105DX 26LG	28480	9100-2258

A39 PLL3 Upconverter Component-Level Troubleshooting

Table A39-2. A39 PLL3 Upconverter Replaceable Parts

Reference Designation	HP Part Number	C D	Qty	Description	Mfr Code	Mfr Part Number
A39L6	9100-2258	7		INDUCTOR RF-CH-MLD 1.2UH 10% .105DX.26LG	28480	9100-2258
A39L7	9100-2258	7		INDUCTOR RF-CH-MLD 1.2UH 10% .105DX.26LG	28480	9100-2258
A39L8	9100-2257	6	1	INDUCTOR RF-CH-MLD 820NH 10% .105DX.26LG	28480	9100-2257
A39L9	9100-2254	3	1	INDUCTOR RF-CH-MLD 390NH 10% .105DX.26LG	28480	9100-2254
A39L10	9100-2258	7		INDUCTOR RF-CH-MLD 1.2UH 10% .105DX.26LG	28480	9100-2258
A39L11	85660-80006	6	3	INDUCTOR-120 NH	28480	85660-80006
A39L12	9100-2255	4	1	INDUCTOR RF-CH-MLD 470NH 10% .105DX.26LG	28480	9100-2255
A39L13	9100-2258	7		INDUCTOR RF-CH-MLD 1.2UH 10% .105DX.26LG	28480	9100-2258
A39L14	9100-2258	7		INDUCTOR RF-CH-MLD 1.2UH 10% .105DX.26LG	28480	9100-2258
A39L15	9135-0073	3	2	INDUCTOR RF-CH-MLD 51NH 6% .102DX.26LG	28480	9135-0073
A39L16	85660-80006	6		INDUCTOR-120 NH	28480	85660-80006
A39L17	85660-80006	6		INDUCTOR-120 NH	28480	85660-80006
A39L18	9135-0073	3		INDUCTOR RF-CH-MLD 51NH 6% .102DX.26LG	28480	9135-0073
A39L19	9100-2258	7		INDUCTOR RF-CH-MLD 1.2UH 10% .105DX.26LG	28480	9100-2258
A39L20	9100-2251	0	1	INDUCTOR RF-CH-MLD 220NH 10% .105DX.26LG	28480	9100-2251
A39L21	9140-0158	6	1	INDUCTOR RF-CH-MLD 1UH 10% .105DX.26LG	28480	9140-0158
A39L22	9140-0144	0	1	INDUCTOR RF-CH-MLD 4.7UH 10% .105DX.26LG	28480	9140-0144
A39MP1	1200-0172	4	5	INSULATOR-XSTR DAP-GL	28480	1200-0172
A39MP2	1200-0172	4		INSULATOR-XSTR DAP-GL	28480	1200-0172
A39MP3	1200-0172	4		INSULATOR-XSTR DAP-GL	28480	1200-0172
A39MP4	1200-0172	4		INSULATOR-XSTR DAP-GL	28480	1200-0172
A39MP5	1200-0172	4		INSULATOR-XSTR DAP-GL	28480	1200-0172
A39MP6	2190-0124	4	6	WASHER-LK INTL T NO. 10 .195-IN-ID	28480	2190-0124
A39MP7	2190-0124	4		WASHER-LK INTL T NO. 10 .195-IN-ID	28480	2190-0124
A39MP8	2190-0124	4		WASHER-LK INTL T NO. 10 .195-IN-ID	28480	2190-0124
A39MP9	2190-0124	4		WASHER-LK INTL T NO. 10 .195-IN-ID	28480	2190-0124
A39MP10	2190-0124	4		WASHER-LK INTL T NO. 10 .195-IN-ID	28480	2190-0124
A39MP11	2190-0124	4		WASHER-LK INTL T NO. 10 .195-IN-ID	28480	2190-0124
A39MP12	2200-0101	0	2	SCREW-MACH 4-40 .188-IN-LG PAN-HD-POZI	00000	ORDER BY DESCRIPTION
A39MP13	2200-0101	0		SCREW-MACH 4-40 .188-IN-LG PAN-HD-POZI	00000	ORDER BY DESCRIPTION
A39MP14	2950-0078	9	3	NUT-HEX-DBL-CHAM 10-32-THD .067-IN-THK	28480	2950-0078
A39MP15	2950-0078	9		NUT-HEX-DBL-CHAM 10-32-THD .067-IN-THK	28480	2950-0078
A39MP16	2950-0078	9		NUT-HEX-DBL-CHAM 10-32-THD .067-IN-THK	28480	2950-0078
A39MP17	08340-20085	6	1	COVER-PC PLL1 UPCONVERTER	28480	08340-20085
A39MP18	85660-00042	2	1	SHIELDING CAN	28480	85660-00042
A39MP19	85660-20068	4	3	GROUND LUG	28480	85660-20068
A39MP20	85660-20068	4		GROUND LUG	28480	85660-20068
A39MP21	85660-20068	4		GROUND LUG	28480	85660-20068
A39MP22	88701-40001	9	1	EXTRACTOR-PC BOARD	28480	88701-40001
A39MP23	3050-0082	8	1	WASHER-FL NM NO. 4 .116-IN-ID .188-IN-OD	28480	3050-0082
A39Q1	1854-0345	8	4	TRANSISTOR NPN 2N5179 SI TO-72 PD=200MW	04713	2N5179
A39Q2	1854-0345	8		TRANSISTOR NPN 2N5179 SI TO-72 PD=200MW	04713	2N5179
A39Q3	1854-0345	8		TRANSISTOR NPN 2N5179 SI TO-72 PD=200MW	04713	2N5179
A39Q4	1854-0345	8		TRANSISTOR NPN 2N5179 SI TO-72 PD=200MW	04713	2N5179
A39Q5	1855-0327	8	1	TRANSISTOR J-FET 2N4416 N-CHAN D-MODE	01295	2N4416
A39R1	0698-3440	7	3	RESISTOR 196 1% .125W F TC=0±100	24546	C4-1/8-T0-196R-F
A39R2	0757-0394	0	2	RESISTOR 51 1 1% .125W F TC=0±100	24546	C4-1/8-T0-51R1-F
A39R3	0698-0083	8	3	RESISTOR 1.96K 1% .125W F TC=0±100	24546	C4-1/8-T0-1961-F
A39R4	0757-0418	9	1	RESISTOR 619 1% .125W F TC=0±100	24546	C4-1/8-T0-619R-F
A39R5	0757-0280	3	5	RESISTOR 1K 1% .125W F TC=0±100	24546	C4-1/8-T0-1001-F
A39R6	0757-0280	3		RESISTOR 1K 1% .125W F TC=0±100	24546	C4-1/8-T0-1001-F
A39R7	0698-3159	5	2	RESISTOR 28 1K 1% .125W F TC=0±100	24546	C4-1/8-T0-2812-F
A39R8	0698-3159	5		RESISTOR 28 1K 1% .125W F TC=0±100	24546	C4-1/8-T0-2612-F
A39R9	0757-0280	3		RESISTOR 1K 1% .125W F TC=0±100	24546	C4-1/8-T0-1001-F
A39R10	0757-0280	3		RESISTOR 1K 1% .125W F TC=0±100	24546	C4-1/8-T0-1001-F
A39R11	0757-0438	3	3	RESISTOR 5.11K 1% .125W F TC=0±100	24546	C4-1/8-T0-5111-F
A39R12	0757-0441	8	3	RESISTOR 8.25K 1% .125W F TC=0±100	24546	C4-1/8-T0-8251-F
A39R13	0757-0438	3		RESISTOR 5.11K 1% .125W F TC=0±100	24546	C4-1/8-T0-5111-F
A39R14	0698-3160	8	1	RESISTOR 31.6K 1% .125W F TC=0±100	24546	C4-1/8-T0-3162-F
A39R15	0698-3447	4	1	RESISTOR 422 1% .125W F TC=0±100	24546	C4-1/8-T0-422R-F
A39R16	0757-0441	8		RESISTOR 8.25K 1% .125W F TC=0±100	24546	C4-1/8-T0-8251-F
A39R17	0757-0441	8		RESISTOR 8.25K 1% .125W F TC=0±100	24546	C4-1/8-T0-8251-F
A39R18	0757-0438	3		RESISTOR 5.11K 1% .125W F TC=0±100	24546	C4-1/8-T0-5111-F
A39R19	0757-0346	2	4	RESISTOR 10 1% .125W F TC=0±100	24546	C4-1/8-T0-10R0-F
A39R20	0757-0346	2		RESISTOR 10 1% .125W F TC=0±100	24546	C4-1/8-T0-10R0-F

A39 PLL3 Upconverter Component-Level Troubleshooting

Table A39-2. A39 PLL3 Upconverter Replaceable Parts

Reference Designation	HP Part Number	C D	Qty	Description	Mfr Code	Mfr Part Number
A39R21	0757-0346	2		RESISTOR 10 1% .125W F TC=0±100	24546	C4-1/8-T0-10R0-F
A39R22	0757-0421	4	1	RESISTOR 825 1% .125W F TC=0±100	24546	C4-1/8-T0-825R-F
A39R23	0757-0466	7	1	RESISTOR 110K 1% .125W F TC=0±100	24546	C4-1/8-T0-1103-F
A39R24	0698-3156	2	2	RESISTOR 14.7K 1% .125W F TC=0±100	24546	C4-1/8-T0-1472-F
A39R25	0698-0083	8		RESISTOR 1.96K 1% .125W F TC=0±100	24546	C4-1/8-T0-1961-F
A39R26	0698-0083	8		RESISTOR 1.96K 1% .125W F TC=0±100	24546	C4-1/8-T0-1961-F
A39R27	0698-3440	7		RESISTOR 196 1% .125W F TC=0±100	24546	C4-1/8-T0-196R-F
A39R28	0757-0346	2		RESISTOR 10 1% .125W F TC=0±100	24546	C4-1/8-T0-10R0-F
A39R29	0757-0397	3	2	RESISTOR 68.1 1% .125W F TC=0±100	24546	C4-1/8-T0-68R1-F
A39R30	0757-0280	3		RESISTOR 1K 1% .125W F TC=0±100	24546	C4-1/8-T0-1001-F
A39R31	0698-3156	2		RESISTOR 14.7K 1% .125W F TC=0±100	24546	C4-1/8-T0-1472-F
A39R32	0698-7219	6	1	RESISTOR 196 1% .05W F TC=0±100	24546	C3-1/8-T0-196R-F
A39R33	0757-0397	3		RESISTOR 68.1 1% .125W F TC=0±100	24546	C4-1/8-T0-68R1-F
A39R34	0698-3440	7		RESISTOR 196 1% .125W F TC=0±100	24546	C4-1/8-T0-196R-F
A39R35	0757-0394	0		RESISTOR 51.1 1% .125W F TC=0±100	24546	C4-1/8-T0-51R1-F
A39R36	0757-0279	0	1	RESISTOR 3.16K 1% .125W F TC=0±100	24546	C4-1/8-T0-3161-F
A39R37	0757-1094	9	1	RESISTOR 1.47K 1% .125W F TC=0±100	24546	C4-1/8-T0-1471-F
A39R38	0698-7192	4	1	RESISTOR 14.7 1% .05W F TC=0±100	24546	C3-1/8-T0-14R7-F
A39R39	0698-7230	1	2	RESISTOR 562 1% .05W F TC=0±100	24546	C3-1/8-T0-562R-F
A39R40	0698-7188	8	1	RESISTOR 10 1% .05W F TC=0±100	24546	C3-1/8-T0-10R-F
A39R41	0698-7200	5	2	RESISTOR 31.6 1% .05W F TC=0±100	24546	C3-1/8-T0-31R6-F
A39R42	0698-7236	7	2	RESISTOR 1K 1% .05W F TC=0±100	24546	C3-1/8-T0-1001-F
A39R43	0698-7248	1	1	RESISTOR 3.16K 1% .05W F TC=0±100	24546	C3-1/8-T0-3161-F
A39R44	0698-7236	7		RESISTOR 1K 1% .05W F TC=0±100	24546	C3-1/8-T0-1001-F
A39R45	0698-7230	1		RESISTOR 562 1% .05W F TC=0±100	24546	C3-1/8-T0-562R-F
A39R46	0698-7218	5	2	RESISTOR 178 1% .05W F TC=0±100	24546	C3-1/8-T0-178R-F
A39R47	0698-7200	5		RESISTOR 31.6 1% .05W F TC=0±100	24546	C3-1/8-T0-31R6-F
A39R48	0698-7218	5		RESISTOR 178 1% .05W F TC=0±100	24546	C3-1/8-T0-178R-F
A39R49	0698-7207	2	1	RESISTOR 61.9 1% .05W F TC=0±100	24546	C3-1/8-T0-61R9-F
A39TP1	0360-0535	0	3	TERMINAL TEST POINT PCB	00000	ORDER BY DESCRIPTION
A39TP2	0360-0535	0		TERMINAL TEST POINT PCB	00000	ORDER BY DESCRIPTION
A39TP3	0360-0535	0		TERMINAL TEST POINT PCB	00000	ORDER BY DESCRIPTION
A39U1	1826-0092	3	1	IC OP AMP GP DUAL TO-99 PKG	28480	1826-0092
A39U2	1826-0261	8	1	IC OP AMP LOW-NOISE TO-99 PKG	28480	1826-0261
A39U3	1820-1383	5	1	IC CNTR ECL BCD POS-EDGE-TRIG	04713	MC10138L
A39U4	1810-0205	7	1	NETWORK-RES 8-SIP4.7K OHM X 7	01121	208A472
A39U5	1820-0817	8	1	IC FF ECL D-M/S DUAL	04713	MC10131P
A39U6	1820-0802	1	1	IC GATE ECL NOR QUAD 2-INP	04713	MC10102P
A39U7	0955-0063	0	1		28480	0955-0063
A39W1	08340-60109	9	1	CABLE ASSEMBLY-A39	28480	08340-60109

A40 Phase Lock Loop 2 VCO Circuit Description

ASSEMBLY PURPOSE

The A40 PLL2 voltage controlled oscillator (VCO) assembly uses the tuning current from the A43 PLL2 discriminator to adjust the VCO frequency between 150 and 75 MHz. This signal is used by four circuits:

- The A42 PLL2 divider, to allow phase-locking of the PLL2 loop.
- Divided by 500, it provides PLL2 loop analog feedback via the A43 PLL2 discriminator.
- Divided by either 25 or 500, depending on the current YIG oscillator sweep width, and is used by the A39 PLL3 upconverter. The higher divide number provides greater signal resolution. PLL3 and PLL1 convert the frequency range of this signal which then phase-locks the YO (YIG oscillator) loop.
- Divided by five, it phase-locks the YO loop directly.

BIAS NETWORK/50 kHz LOW-PASS FILTER (BLOCK A)

A low pass filter attenuates frequencies above 50 kHz. The undesired frequencies from the A43 PLL2 discriminator are normally between 150 kHz to 300 kHz. The input signal is a current source (1 to 9 mA). The filter is in series with the tuning current to reduce the effects of 50 or 60 Hz noise (caused by the AC line voltage). Any stray signals coupled to the filter inductors will appear as a series voltage signal. Since the tuning current comes from a current source on the A43 discriminator, it will not be affected by voltage changes on the inductors.

At the minimum tuning current, the varactor bias (block B) is set by R2 (150 MHz ADJUST). This is a VCO offset adjustment. As tuning current from the A43 PLL2 discriminator increases, it forces the tune voltage more positive, in proportional to the setting of R4 (100 MHz ADJUST). This is the VCO gain adjustment, which is set for about -10 MHz/mA sensitivity. These adjustments are normally made when the loop is phase-locked. When phase-locked, the VCO frequency will exactly equal the programmed frequency, so rather than adjusting for a frequency indication, the adjustments are made by monitoring the tuning voltage on the A43 PLL2 discriminator and setting the end points to the appropriate voltages.

Transistors Q5 and Q6 and associated components form a low-impedance filtered -32 V source to bias the VCO varactor tuning diodes.

VCO (BLOCK B)

The VCO is a varactor tuned oscillator which tunes from 75 to 150 MHz. Varactors CR1, CR2, CR3, and CR4 form a series resonant circuit with L4 and L5. Figure A40-1 shows the oscillator's equivalent circuit. This series circuit connects the emitters of Q1 and Q2. Q2 is a common-base amplifier whose load impedance is made up of L9, R14, and R15. The voltage across the load is coupled to the base of emitter-follower Q1, which drives the series resonant circuit. There is no phase inversion through Q2 (emitter-to-collector) or through Q1 (base-to-emitter), so the feedback signal is in phase with the input signal.

The VCO tuning voltage at TP1 in VCO (block B) is a function of the current from the A43 PLL2 discriminator flowing through a current to voltage converter R1-R5. The tuning current passes through the 50 kHz filter and into R1-R5. Varactor diodes CR1-CR4 are reverse biased, causing negligible current to flow through L3.

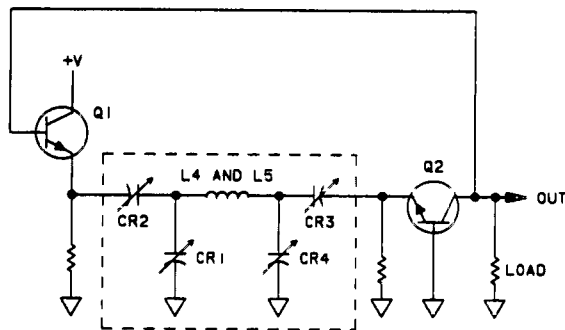

Figure A40-1. Equivalent VCO Resonant Circuit

75-150 MHz OUTPUT BUFFER (BLOCK C)

A grounded-base amplifier isolates the VCO from the load circuits. The output of Q4 is filtered, attenuated, and used to drive the A42 PLL2 Divider.

R20, R21, and R22 form a 13 dB attenuator. The output is attenuated to reduce the possibility of coupling this signal into other circuits. A pre-amplifier on the A42 PLL2 Divider returns the signal to the required level. This signal path is used during phase-locking only, so its response below 100 MHz is not important. (PLL2 is only programmable to phase-lock frequencies between 100 MHz and 150 MHz.)

FREQUENCY DIVIDERS (BLOCK D)

Q3 isolates the VCO from the dividers and develops the drive voltage required by subsequent circuits. All of the dividers and gates are ECL with Vcc connected to +5V and Vee grounded. As shown in Figure A40-2, the VCO frequency is divided by five to obtain 15 to 30 MHz. U2 provides two outputs:

- Divide by five (3 to 6 MHz), used in block E.
- Divide by ten (1.5 to 3 MHz), input to another divide-by-ten stage, which provides 0.15 to 0.3 MHz used by the PLL2 discriminator.

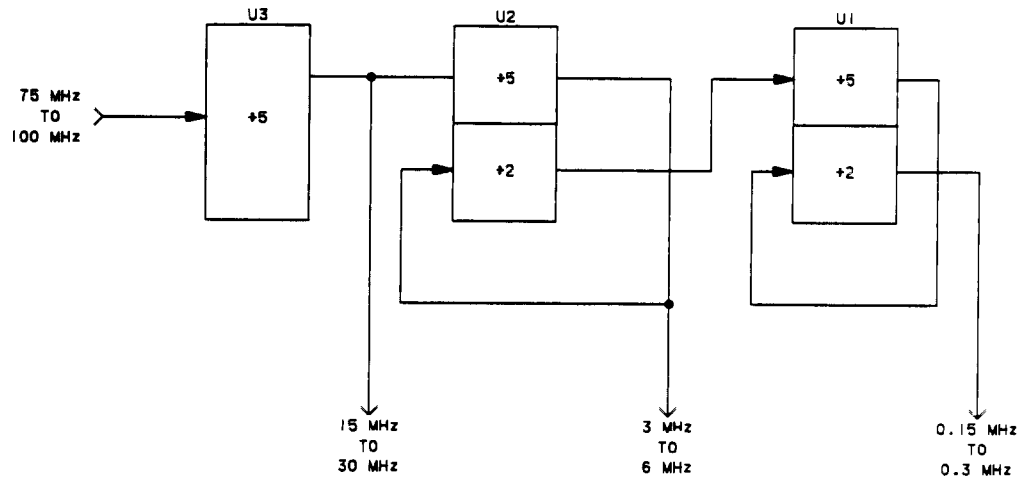

Figure A40-2. Simplified Divider Circuit

SMALL DELTA F SWITCH (BLOCK E)

U5A and U5B form a single-pole double-throw switch, routing either the 3 to 6 MHz signal from U2 (block D) or the 0.15 to 0.30 MHz signal from U1 (block D), to the A39 PLL3 upconverter. The required range is selected SW2, a TTL signal from the A42 PLL2 Divider. R33 and R34 shift the TTL levels to ECL levels.

For 20-30 loop sweeps between 5 kHz and 100 kHz, SW2 is a TTL high and the 3 to 6 MHz divider output is routed to the A39 PLL3 upconverter. For sweeps less than 5 kHz, SW2 is TTL low, selecting the 0.15 to 0.30 MHz output.

0.1 TO 5 MHz DELTA F SWITCH (BLOCK F)

For YIG oscillator sweep widths between 0.1 and ≤ 5 MHz, the 15 to 30 MHz output is used. The 15 to 30 MHz output of the frequency dividers (block D) is routed through block F. Block F circuitry serves as a switch with 90 dB of isolation in the off state. SW1, a TTL signal from the A42 PLL2 divider, switches the output from block F on or off.

A40 PLL2 VCO Component-Level Troubleshooting

Table A40-1. A40 PLL2 VCO Pin I/O

Pin	Mnemonic	Levels	Source	Destination
1 16				
2 17	GND GND	0V 0V	A62 STAR GND A62 STAR GND	*G *G
3 18	GND	0V	A62 STAR GND A62 STAR GND	*G
4 19	GND	0V	A62 STAR GND A62 STAR GND	*G
5 20	GND	0V	A62 STAR GND A62 STAR GND	*G
6 21	GND GND	0V 0V	A62 STAR GND A62 STAR GND	*G *G
7 22	SW2	TTL	XA42P1-14	E
8 23				
9 24	SW1	TTL	XA42P1-32	*F
10 25	GND GND	0V 0V	A62 STAR GND A62 STAR GND	*G *G
11 26	-40V/-40V SENSE (-) -40V/-40V SENSE (-)	-40V -40V	XA5301-11,30/XA53P1-23 XA53P1-11, 30/XA53P1-23	*A *A
12 27	-10V -10V	-10V -10V	XA53P1-12, 13, 31, 32 XA53P1-12, 13, 31, 32	*G *G
13 28	+20V +20V	+20V +20V	XA52P1-16, 40 XA52P1-16, 40	*G *G
14 29	GND GND	0V 0V	A62 STAR GND A62 STAR GND	*G *G
15 30	+5.2V +5.2V	+5.2V +5.2V	XA52P1-17,18,41,42 XA52P1-17, 18, 41, 42	*G *G

A single letter in the source or destination column refers to a function block on this assembly schematic.

An asterisk (*) denotes multiple sources or destinations; refer to the A62 motherboard wiring list for a complete representation of signal sources and destinations.

A40 PLL2 VCO Component-Level Troubleshooting

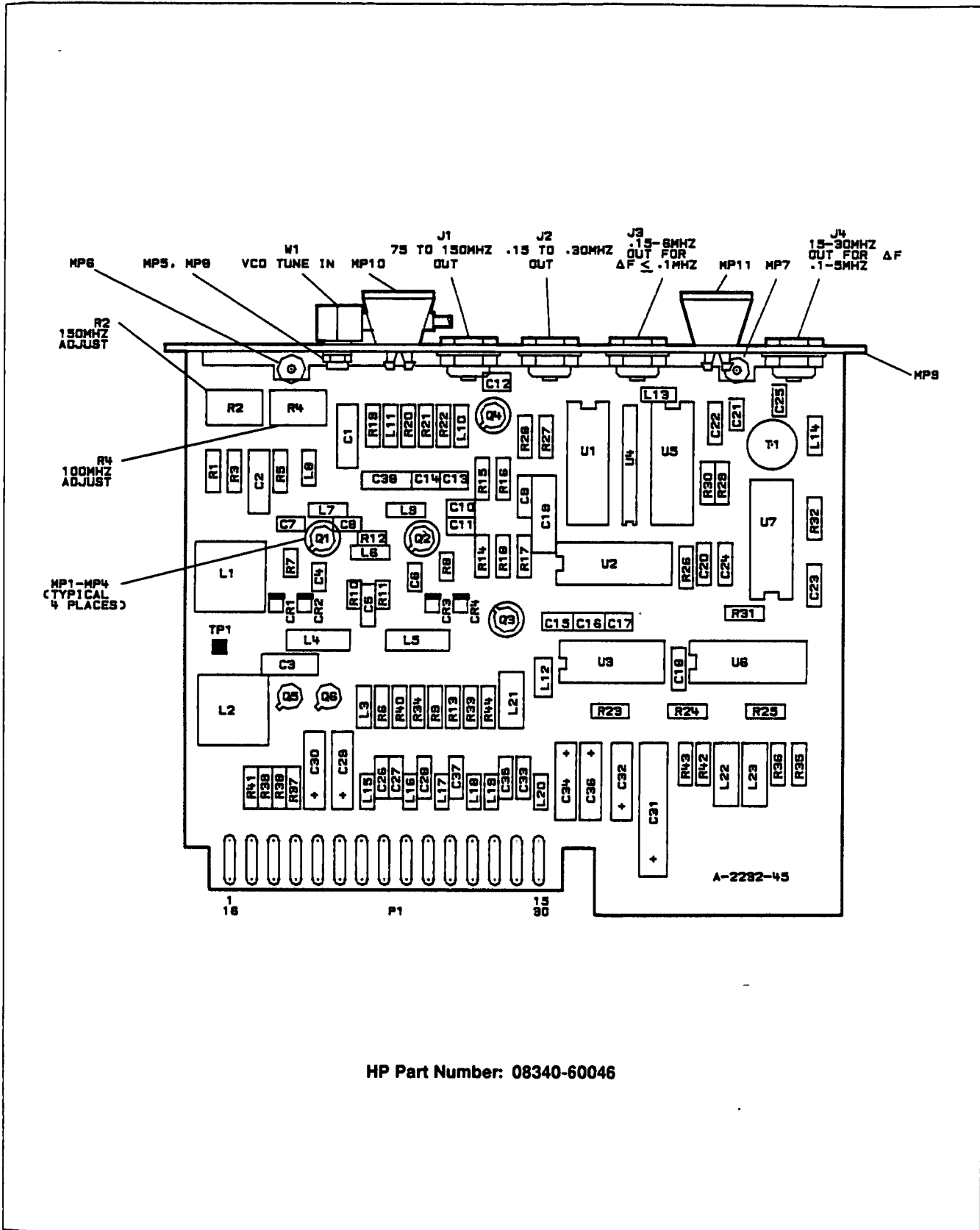

A40 PLL2 VCO Component-Level Troubleshooting

Table A40-2. A40 PLL2 VCO Replaceable Parts

Reference Designation	HP Part Number	C D	Qty	Description	Mfr Code	Mfr Part Number
A40	08340-60046	3	1	PLL2 VCO	28480	08340-60046
A40C1	0160-0300	3	1	CAPACITOR-FXD 2700PF ± 10% 200VDC POLYE	28480	0160-0300
A40C2	0160-0155	6	1	CAPACITOR-FXD 3300PF ± 10% 200VDC POLYE	28480	0160-0155
A40C3	0160-0154	5	1	CAPACITOR-FXD 2200PF ± 10% 200VDC POLYE	28480	0160-0154
A40C4	0160-3879	7	4	CAPACITOR-FXD 01UF ± 20% 100VDC CER	28480	0160-3879
A40C5	0160-4084	8	14	CAPACITOR-FXD .1UF ± 20% 50VDC CER	28480	0160-4084
A40C6	0160-3879	7		CAPACITOR-FXD 01UF ± 20% 100VDC CER	28480	0160-3879
A40C7	0160-3879	7		CAPACITOR-FXD 01UF ± 20% 100VDC CER	28480	0160-3879
A40C8	0160-3878	6	6	CAPACITOR-FXD 1000PF ± 20% 100VDC CER	28480	0160-3878
A40C9	0160-4084	8		CAPACITOR-FXD 1UF ± 20% 50VDC CER	28480	0160-4084
A40C10	0160-3878	6		CAPACITOR-FXD 1000PF ± 20% 100VDC CER	28480	0160-3878
A40C11	0160-3878	6		CAPACITOR-FXD 1000PF ± 20% 100VDC CER	28480	0160-3878
A40C12	0160-4525	2	1	CAPACITOR-FXD 29PF ± 5% 200VDC CER 0 ± 30	28480	0160-4525
A40C13	0160-4524	1	1	CAPACITOR-FXD 24PF ± 5% 200VDC CER 0 ± 30	51642	200-200-NPO-240J
A40C14	0160-3879	7		CAPACITOR-FXD 01UF ± 20% 100VDC CER	28480	0160-3879
A40C15	0160-3878	6		CAPACITOR-FXD 1000PF ± 20% 100VDC CER	28480	0160-3878
A40C16	0160-3878	6		CAPACITOR-FXD 1000PF ± 20% 100VDC CER	28480	0160-3878
A40C17	0160-3878	6		CAPACITOR-FXD 1000PF ± 20% 100VDC CER	28480	0160-3878
A40C18	0160-4084	8		CAPACITOR-FXD .1UF ± 20% 50VDC CER	28480	0160-4084
A40C19	0160-0127	2	1	CAPACITOR-FXD 1UF ± 20% 25VDC CER	28480	0160-0127
A40C20	0160-4084	8		CAPACITOR-FXD 1UF ± 20% 50VDC CER	28480	0160-4084
A40C21	0160-0571	0	1	CAPACITOR-FXD 470PF ± 20% 100VDC CER	28480	0160-0571
A40C22	0160-4084	8		CAPACITOR-FXD .1UF ± 20% 50VDC CER	28480	0160-4084
A40C23	0160-4084	8		CAPACITOR-FXD 1UF ± 20% 50VDC CER	28480	0160-4084
A40C24	0160-4084	8		CAPACITOR-FXD 1UF ± 20% 50VDC CER	28480	0160-4084
A40C25	0160-3877	5	1	CAPACITOR-FXD 100PF ± 20% 200VDC CER	28480	0160-3877
A40C26	0160-4084	8		CAPACITOR-FXD 1UF ± 20% 50VDC CER	28480	0160-4084
A40C27	0160-4084	8		CAPACITOR-FXD 1UF ± 20% 50VDC CER	28480	0160-4084
A40C28	0160-4084	8		CAPACITOR-FXD 1UF ± 20% 50VDC CER	28480	0160-4084
A40C29	0180-2141	6	2	CAPACITOR-FXD 3.3UF ± 10% 50VDC TA	56289	150D335X9050B2
A40C30	0180-2141	6		CAPACITOR-FXD 3.3UF ± 10% 50VDC TA	56289	150D335X9050B2
A40C31	0180-1715	8	1	CAPACITOR-FXD 150UF ± 10% 6VDC TA	56289	150D157X9006R2
A40C32	0180-1746	5	2	CAPACITOR-FXD 15UF ± 10% 20VDC TA	56289	150D156X9020B2
A40C33	0160-4084	8		CAPACITOR-FXD 1UF ± 20% 50VDC CER	28480	0160-4084
A40C34	0180-0229	7	1	CAPACITOR-FXD 33UF ± 10% 10VDC TA	56289	150D336X9010B2
A40C35	0160-4084	8		CAPACITOR-FXD 1UF ± 20% 50VDC CER	28480	0160-4084
A40C36	0180-1746	5		CAPACITOR-FXD 15UF ± 10% 20VDC TA	56289	150D156X9020B2
A40C37	0160-4084	8		CAPACITOR-FXD 1UF ± 20% 50VDC CER	28480	0160-4084
A40C38	0160-4084	8		CAPACITOR-FXD 1UF ± 20% 50VDC CER	28480	0160-4084
A40CR1	0122-0085	1	4	DIODE-VVC 2.2PF 7% C3/C25-MIN=4.5	02032	SMV1288
A40CR2	0122-0085	1		DIODE-VVC 2.2PF 7% C3/C25-MIN=4.5	02032	SMV1288
A40CR3	0122-0085	1		DIODE-VVC 2.2PF 7% C3/C25-MIN=4.5	02032	SMV1288
A40CR4	0122-0085	1		DIODE-VVC 2.2PF 7% C3/C25-MIN=4.5	02032	SMV1288
A40J1	1250-0544	9	5	CONNECTOR-RF MALE SMB	28480	1250-0544
A40J2	1250-0544	9		CONNECTOR-RF MALE SMB	28480	1250-0544
A40J3	1250-0544	9		CONNECTOR-RF MALE SMB	28480	1250-0544
A40J4	1250-0544	9		CONNECTOR-RF MALE SMB	28480	1250-0544
A40J5	1250-0544	9		CONNECTOR-RF MALE SMB	28480	1250-0544
A40L1	85660-80031	7	2	INDUCTOR	28480	85660-80031
A40L2	85660-80031	7		INDUCTOR	28480	85660-80031
A40L3	9140-0144	0	1	INDUCTOR RF-CH-MLD 4.7UH 10% 105DX 26LG	28480	9140-0144
A40L4	9100-3358	0	2	INDUCTOR RF-CH-MLD 162NH 5% 2DX 385LG	28480	9100-3358
A40L5	9100-3358	0		INDUCTOR RF-CH-MLD 162NH 5% 2DX 385LG	28480	9100-3358
A40L6	9100-2251	0	1	INDUCTOR RF-CH-MLD 220NH 10% 105DX 26LG	28480	9100-2251
A40L7	9140-0158	6	2	INDUCTOR RF-CH-MLD 1UH 10% 105DX 26LG	28480	9140-0158
A40L8	9100-2247	4	8	INDUCTOR RF-CH-MLD 100NH 10% 105DX 26LG	28480	9100-2247
A40L9	9100-2891	4	2	INDUCTOR RF-CH-MLD 50NH 10% 105DX 26LG	28480	9100-2891
A40L10	9100-2891	4		INDUCTOR RF-CH-MLD 50NH 10% 105DX 26LG	28480	9100-2891
A40L11	9140-0158	6		INDUCTOR RF-CH-MLD 1UH 10% 105DX 26LG	28480	9140-0158
A40L12	9100-2247	4		INDUCTOR RF-CH-MLD 100NH 10% 105DX 26LG	28480	9100-2247
A40L13	9100-2258	7	1	INDUCTOR RF-CH-MLD 1.2UH 10% 105DX 26LG	28480	9100-2258
A40L14	9100-2250	9	1	INDUCTOR RF-CH-MLD 180NH 10% 105DX 26LG	28480	9100-2250
A40L15	9100-2247	4		INDUCTOR RF-CH-MLD 100NH 10% 105DX 26LG	28480	9100-2247
A40L16	9100-2247	4		INDUCTOR RF-CH-MLD 100NH 10% 105DX 26LG	28480	9100-2247
A40L17	9100-2247	4		INDUCTOR RF-CH-MLD 100NH 10% 105DX 26LG	28480	9100-2247
A40L18	9100-2247	4		INDUCTOR RF-CH-MLD 100NH 10% 105DX 26LG	28480	9100-2247
A40L19	9100-2247	4		INDUCTOR RF-CH-MLD 100NH 10% 105DX 26LG	28480	9100-2247
A40L20	9100-2247	4		INDUCTOR RF-CH-MLD 100NH 10% 105DX 26LG	28480	9100-2247

A40 PLL2 VCO Component-Level Troubleshooting

Table A40-2. A40 PLL2 VCO Replaceable Parts

Reference Designation	HP Part Number	C D	Qty	Description	Mfr Code	Mfr Part Number
A40L21	9100-1618	1	3	INDUCTOR RF-CH-MLD 5.6UH 10%	28480	9100-1618
A40L22	9100-1618	1		INDUCTOR RF-CH-MLD 5.6UH 10%	28480	9100-1618
A40L23	9100-1618	1		INDUCTOR RF-CH-MLD 5.6UH 10%	28480	9100-1618
A40MP1	1200-0172	4	4	INSULATOR-XSTR DAP-GL	28480	1200-0172
A40MP2	1200-0172	4		INSULATOR-XSTR DAP-GL	28480	1200-0172
A40MP3	1200-0172	4		INSULATOR-XSTR DAP-GL	28480	1200-0172
A40MP4	1200-0172	4		INSULATOR-XSTR DAP-GL	28480	1200-0172
A40MP5	2190-0124	4	1	WASHER-LK INTL T NO. 10 195-IN-ID	28480	2190-0124
A40MP6	2200-0101	0	2	SCREW-MACH 4-40 188-IN-LG PAN-HD-POZI	00000	ORDER BY DESCRIPTION
A40MP7	2200-0101	0		SCREW-MACH 4-40 188-IN-LG PAN-HD-POZI	00000	ORDER BY DESCRIPTION
A40MP8	2950-0078	9	1	NUT-HEX-DBL-CHAM 10-32-THD 067-IN-THK	28480	2950-0078
A40MP9	08340-20086	7	1	COVER-PC PLL2 VCO	28480	08340-20086
A40MP10	86701-40001	9	2	EXTRACTOR-PC BOARD	28480	86701-40001
A40MP11	86701-40001	9		EXTRACTOR-PC BOARD	28480	86701-40001
A40Q1	1854-0610	0	2	TRANSISTOR NPN SI TO-46 FT=800MHZ	28480	1854-0610
A40Q2	1854-0610	0		TRANSISTOR NPN SI TO-46 FT=800MHZ	28480	1854-0610
A40Q3	1854-0345	8	2	TRANSISTOR NPN 2N5179 SI TO-72 PD=200MW	04713	2N5179
A40Q4	1854-0345	8		TRANSISTOR NPN 2N5179 SI TO-72 PD=200MW	04713	2N5179
A40Q5	1853-0281	9	2	TRANSISTOR PNP 2N2907A SI TO-18 PD=400MW	04713	2N2907A
A40Q6	1853-0281	9		TRANSISTOR PNP 2N2907A SI TO-18 PD=400MW	04713	2N2907A
A40R1	0698-0085	0	1	RESISTOR 2.81K 1% 125W F TC=0±100	24546	C4-1/8-T0-2611-F
A40R2	2100-3273	1	2	RESISTOR-TRMR 2K 10% C SIDE-ADJ 1-TRN	28480	2100-3273
A40R3	0757-0428	1	1	RESISTOR 1.62K 1% 125W F TC=0±100	24546	C4-1/8-T0-1621-F
A40R4	2100-3273	1		RESISTOR-TRMR 2K 10% C SIDE-ADJ 1-TRN	28480	2100-3273
A40R5	0757-0447	4	1	RESISTOR 16.2K 1% 125W F TC=0±100	24546	C4-1/8-T0-1622-F
A40R6	0757-0401	0	3	RESISTOR 100 1% 125W F TC=0±100	24546	C4-1/8-T0-101-F
A40R7	0698-7205	0	2	RESISTOR 51.1 1% 05W F TC=0±100	24546	C3-1/8-T0-51R1-F
A40R8	0698-7205	0		RESISTOR 51.1 1% 05W F TC=0±100	24546	C3-1/8-T0-51R1-F
A40R9	0757-0346	2	4	RESISTOR 10 1% 125W F TC=0±100	24546	C4-1/8-T0-10R0-F
A40R10	0698-7228	7	2	RESISTOR 464 1% 05W F TC=0±100	24546	C3-1/8-T0-464R-F
A40R11	0698-7228	7		RESISTOR 464 1% 05W F TC=0±100	24546	C3-1/8-T0-464R-F
A40R12	0698-7188	8	1	RESISTOR 10 1% 05W F TC=0±100	24546	C3-1/8-T0-10R-F
A40R13	0757-0346	2		RESISTOR 10 1% 125W F TC=0±100	24546	C4-1/8-T0-10R0-F
A40R14	0757-0398	4	4	RESISTOR 75 1% 125W F TC=0±100	24546	C4-1/8-T0-75R0-F
A40R15	0757-0398	4		RESISTOR 75 1% 125W F TC=0±100	24546	C4-1/8-T0-75R0-F
A40R16	0757-0418	9	1	RESISTOR 619 1% 125W F TC=0±100	24546	C4-1/8-T0-619R-F
A40R17	0757-0346	2		RESISTOR 10 1% 125W F TC=0±100	24546	C4-1/8-T0-10R0-F
A40R18	0757-0419	0	3	RESISTOR 681 1% 125W F TC=0±100	24546	C4-1/8-T0-681R-F
A40R19	0757-0346	2		RESISTOR 10 1% 125W F TC=0±100	24546	C4-1/8-T0-10R0-F
A40R20	0757-0400	9	1	RESISTOR 90.9 1% 125W F TC=0±100	24546	C4-1/8-T0-90R9-F
A40R21	0757-0398	4		RESISTOR 75 1% 125W F TC=0±100	24546	C4-1/8-T0-75R0-F
A40R22	0757-0398	4		RESISTOR 75 1% 125W F TC=0±100	24546	C4-1/8-T0-75R0-F
A40R23	0757-0401	0		RESISTOR 100 1% 125W F TC=0±100	24546	C4-1/8-T0-101-F
A40R24	0698-4037	0	1	RESISTOR 46.4 1% 125W F TC=0±100	24546	C4-1/8-T0-46R4-F
A40R25	0698-0083	8	1	RESISTOR 1.96K 1% 125W F TC=0±100	24546	C4-1/8-T0-1961-F
A40R26	0757-0280	3	5	RESISTOR 1K 1% 125W F TC=0±100	24546	C4-1/8-T0-1001-F
A40R27	0698-3440	7	1	RESISTOR 196 1% 125W F TC=0±100	24546	C4-1/8-T0-196R-F
A40R28	0757-0280	3		RESISTOR 1K 1% 125W F TC=0±100	24546	C4-1/8-T0-1001-F
A40R29	0757-0316	6	1	RESISTOR 42.2 1% 125W F TC=0±100	24546	C4-1/8-T0-42R2-F
A40R30	0757-0280	3		RESISTOR 1K 1% 125W F TC=0±100	24546	C4-1/8-T0-1001-F
A40R31	0757-0280	3		RESISTOR 1K 1% 125W F TC=0±100	24546	C4-1/8-T0-1001-F
A40R32	0698-3446	3	1	RESISTOR 383 1% 125W F TC=0±100	24546	C4-1/8-T0-383R-F
A40R33	0698-3444	1	2	RESISTOR 316 1% 125W F TC=0±100	24546	C4-1/8-T0-316R-F
A40R34	0757-0419	0		RESISTOR 681 1% 125W F TC=0±100	24546	C4-1/8-T0-681R-F
A40R35	0698-3444	1		RESISTOR 316 1% 125W F TC=0±100	24546	C4-1/8-T0-316R-F
A40R36	0757-0419	0		RESISTOR 681 1% 125W F TC=0±100	24546	C4-1/8-T0-681R-F
A40R37	0757-0442	9	2	RESISTOR 10K 1% 125W F TC=0±100	24546	C4-1/8-T0-1002-F
A40R38	0757-0442	9		RESISTOR 10K 1% 125W F TC=0±100	24546	C4-1/8-T0-1002-F
A40R39	0757-0465	6	1	RESISTOR 100K 1% 125W F TC=0±100	24546	C4-1/8-T0-1003-F
A40R40	0757-0280	3		RESISTOR 1K 1% 125W F TC=0±100	24546	C4-1/8-T0-1001-F
A40R41	0757-0401	0		RESISTOR 100 1% 125W F TC=0±100	24546	C4-1/8-T0-101-F
A40R42	0757-0397	3	1	RESISTOR 68 1% 125W F TC=0±100	24546	C4-1/8-T0-68R1-F
A40R43	0698-3132	4	1	RESISTOR 261 1% 125W F TC=0±100	24546	C4-1/8-T0-2610-F
A40R44	0757-0416	7	1	RESISTOR 511 1% 125W F TC=0±100	24546	C4-1/8-T0-511R-F

A40 PLL2 VCO Component-Level Troubleshooting

Table A40-2. A40 PLL2 VCO Replaceable Parts

Reference Designation	HP Part Number	C D	Qty	Description	Mfr Code	Mfr Part Number
A40T1	08553-6012	5	1	TRANSFORMER-RF (BLUE)	28480	08553-6012
A40TP1	0360-0535	0	1	TERMINAL TEST POINT PCB	00000	ORDER BY DESCRIPTION
A40U1	1820-1383	5	2	IC CNTR ECL BCD POS-EDGE-TRIG	04713	MC10138L
A40U2	1820-1383	5		IC CNTR ECL BCD POS-EDGE-TRIG	04713	MC10138L
A40U3	1820-2047	0	1	IC DIVR ECL QUINARY	52648	SP8622BDG
A40U4	1810-0205	7	1	NETWORK-RES 8-SIP4.7K OHM X 7	01121	208A472
A40U5	1820-0802	1	3	IC GATE ECL NOR QUAD 2-INP	04713	MC10102P
A40U6	1820-0802	1		IC GATE ECL NOR QUAD 2-INP	04713	MC10102P
A40U7	1820-0802	1		IC GATE ECL NOR QUAD 2-INP	04713	MC10102P
A40W1	08340-60110	2	1	CABLE ASSEMBLY-A40	28480	08340-60110

A41 Phase Lock Loop 2 Phase Detector Circuit Description

ASSEMBLY PURPOSE

The A41 PLL2 phase detector compares the phase of the A40 PLL2 VCO output signal (after division by N2 on the A42 PLL2 Divider) to a 500 kHz reference signal. The phase difference is converted to an error voltage used to change the sensitivity of the PLL2 discriminator. This fine-tunes the PLL2 VCO frequency.

PHASE-FREQUENCY DETECTOR (BLOCK A)

The phase-frequency detector responds to the phase difference between the following two inputs:

- The 500 kHz reference input (10 MHz from the A29 reference phase detector divided by 20 on the A42 PLL2 divider).
- DIV N2 (the A40 PLL2 VCO output signal) after it is frequency-translated to a fixed 500 kHz frequency. This frequency translation is done by programmable divide circuitry on the A42 PLL2 divider.

Assuming both flip-flops are cleared, Q9 is on and Q10 is off. Q9 supplies about 3 mA current which goes through current source Q8. In this condition, approximately zero current flow goes through the 50 kHz LPF (low-pass filter). C4 stabilizes the two grounds between the sample and the hold modes.

Q8 is on when HLE2 (high lock enable) is high.

A pulse from the PLL2 Divider on P1 pin 19 clocks the Q output of U6A (pin 5) high, turning Q9 off. With both Q9 and Q10 off, Q8 will sink current out of the 50 kHz LPF. A subsequent reference pulse on P1 pin 20 clocks the Q output of U6B (pin 9) high which immediately resets both flip-flops through U7A. If a DIV N2 pulse arrives at P1 pin 19 before a 500 kHz REF pulse arrives at P1 pin 20, current is routed from the 50 kHz LPF into Q8, momentarily reducing the current flow into the 50 kHz LPF.

If the 500 kHz REF phase leads the DIV N2 phase, Q8 will sink Q9 current and Q10 current will be routed through the 50 kHz LPF, momentarily increasing the current flowing into the 50 kHz LPF. Current flow into the LPF will cause the voltage at TP1 to decrease.

If the two inputs have different frequencies, the pulse relationships are complex, but the overall effect is a negative voltage at TP1 if the divided output frequency (P1 pin 19) is higher than the 500 kHz reference (P1 pin 20).

The final stage is an amplifier (U3) which provides the high current necessary to rapidly charge the integrating capacitor C7 (in block C).

HLE2 (P1 pin 2) controls U6A and Q8 (Q8 is controlled via block C). During sweep mode Q8 is off, U6A is set — shutting off Q9. HLE2 also goes to the A42 PLL2 divider, shutting off the 500 kHz input to U6B. With the 500 kHz input off, U7A forces U6B to reset which causes Q10 to shut off. With Q8, Q9, and Q10 off, the voltage at TP1 is forced to zero volts. This prevents any negative voltage from turning Q3 on (block C), and changing the charge stored on C7.

DIGITAL INTEGRATOR (BLOCK B)

The error voltage necessary to phase-lock the loop must be sampled, and then held constant during sweep to preserve frequency accuracy throughout the sweep. If the entire error correction were retained in the analog integrator, it would require extremely low-leakage components to avoid inaccuracy at the end of sweeps. Instead, the digital integrator is used to store the coarse error-voltage component, while the analog integrator stores the fine error-voltage component.

When the analog error voltage (TP3 in block C) goes below -4.7V , Q5 is turned on and its collector voltage is pulled down to -1.4V . This causes CR4 and CR3 to become forward biased, clamping U2 (block C) and keeping TP3 from becoming more negative. Simultaneously, the input of U7B is pulled low, which turns on a 2 kHz oscillator made up of U7C, R20, and C11. This clocks the count-up input of counters U8 and U9, which drive DAC U10. U10 sources negative current to the summing junction of U4 (block D) and this current increases as U8 and U9 count up. When the current reaches a value which tunes the VCO to the proper frequency, the voltage at TP3 moves positive, shutting off the oscillator. A similar sequence occurs when the analog error voltage (TP3) rises above $+6.4\text{V}$, but the counters count down — decreasing the output voltage from the DAC. This occurs during the phase-lock interval, before the sweep begins. During the sweep, any drop in the remaining analog error voltage is insignificant, since the counters contain the majority of the error correction in digital form.

ANALOG INTEGRATOR – SAMPLE AND HOLD (BLOCK C)

U2 and C7 form an integrator which integrates current flowing from the phase/frequency detector (block A). The output of the integrator is summed with other signals in the output amplifier (block D) and ultimately controls the VCO frequency. In steady state conditions, TP3 will settle to a constant voltage which tunes the VCO to the correct frequency. If the voltage at TP3 is constant, the integrator's input current must be zero, so opening the sample and hold FET switch Q3 will not change the voltage at TP3. When PLL2 is being used in its swept mode, the loop is locked to a start frequency set by A42 PLL2 divider, then Q3 is opened. This breaks the phase-lock loop, permitting a sweep to be executed.

Q3 is closed with zero gate voltage, and open with -7V on the gate. The gate drive comes from Q6 and Q7, which translates the TTL HLE2 signal level on P1 pin 2 to the 0/-7V levels. P1 pin 2 also controls U6A and Q8 in the phase/frequency detector (block A).

OUTPUT AMPLIFIER (BLOCK D)

This circuit sums signals from the analog integrator, the digital integrator, and the direct output of the phase/frequency detector (via R11). The R11 path is a high frequency signal path that bypasses the slow responding integrators, and speeds up the phase-locking process. Components in this circuit function with internal resistance in the DAC (block B) to form an active 3 kHz low-pass filter.

The output of this block is the tuning voltage that goes to the A43 PLL2 Discriminator, and changes the gain of the discriminator to tune the PLL2 VCO frequency.

UNLOCK INDICATOR (BLOCK E)

When the phase lock loop is locked, the voltage at TP1 in the phase/frequency detector (block A) is zero. If unlocked, the voltage will not be zero except for transients passing through zero. When the voltage exceeds $\pm 3V$, either Q1 or Q2 is turned on, discharging the respective capacitor and tripping the comparator (notice opposite polarity voltage on the capacitors). When the voltage settles to less than $\pm 3V$, the appropriate capacitor must recharge before the comparator is reset, holding the unlocked indication. Recharging takes about 1 ms, allowing the unlocked indication to be recognized by the microprocessor. The comparator's output is a TTL high for an unlock condition.

A41 PLL2 Phase Detector Component-Level Troubleshooting

Table A41-1. A41 PLL2 Phase Detector Pin I/O

Pin	Mnemonic	Levels	Source	Destination
1 16	GND GND	0V 0V	A62 STAR GND A62 STAR GND	*F *F
2 17	HLE2	TTL (HIGH TRUE)	XA59P1-53	*A B C
3 18	GND GND	0V 0V	A62 STAR GND A62 STAR GND	*F *F
4 19	HUL2 DIV N2	TTL (HIGH TRUE) TTL (LOW TRUE)	E XA42P1-27	XA59P1-107 A
5 20	500 KHZ REF	TTL	XA42P1-9	A
6 21	GND GND	0V 0V	A62 STAR GND A62 STAR GND	*F *F
7 22	-7 REF GND	-7V 0V	XA43P1-9 A62 STAR GND	F *F
8 23	N2 TUNE RTN N2 TUNE	0V 0 TO +7 VOLTS	F D	XA43P1-10 XA43P1-28
9 24				
10 25	GND GND	0V 0V	A62 STAR GND A62 STAR GND	*F *F
11 26	GND GND	0V 0V	A62 STAR GND A62 STAR GND	*F *F
12 27	-10V -10V	-V -10V	XA53P1-12, 13, 31, 32 XA53P1-12, 13, 31, 32	*F *F
13 28	+20V +20V	+20V +20V	XA52P1-16, 40 XA52P1-16, 40	*F *F
14 29	GND GND	0V 0V	A62 STAR GND A62 STAR GND	*F *F
15 30	+5.2V +5.2V	+5.2V +5.2V	XA52P1-17, 18, 41, 42 XA52P1-17, 18, 41, 42	*F *F

A single letter in the source or destination column refers to a function block on this assembly schematic.

An asterisk (*) denotes multiple sources or destinations; refer to the A62 motherboard wiring list for a complete representation of signal sources and destinations.

A41 PLL2 Phase Detector Component-Level Troubleshooting

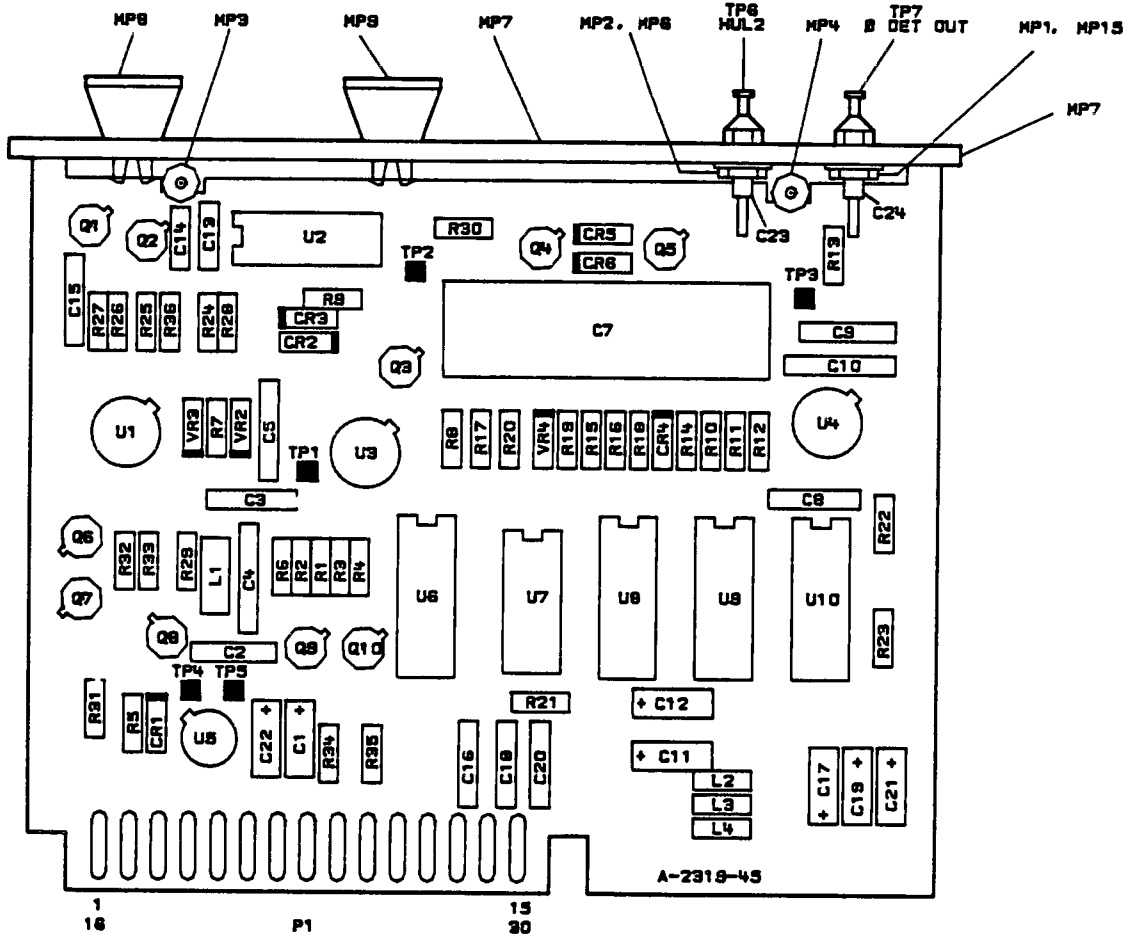

HP Part Number: 08340-60162

Figure A41-1. A41 PLL2 Phase Detector Component Location Diagram

NOTES

1. POSITIONAL TOLERANCES ARE AS SHOWN UNLESS OTHERWISE SPECIFIED.
2. PHASE 4 OF THE PACKAGE TO THE UP AND DOWN CONNECTIONS COMPARED TO US PHASE 4, 1, 2, 3.

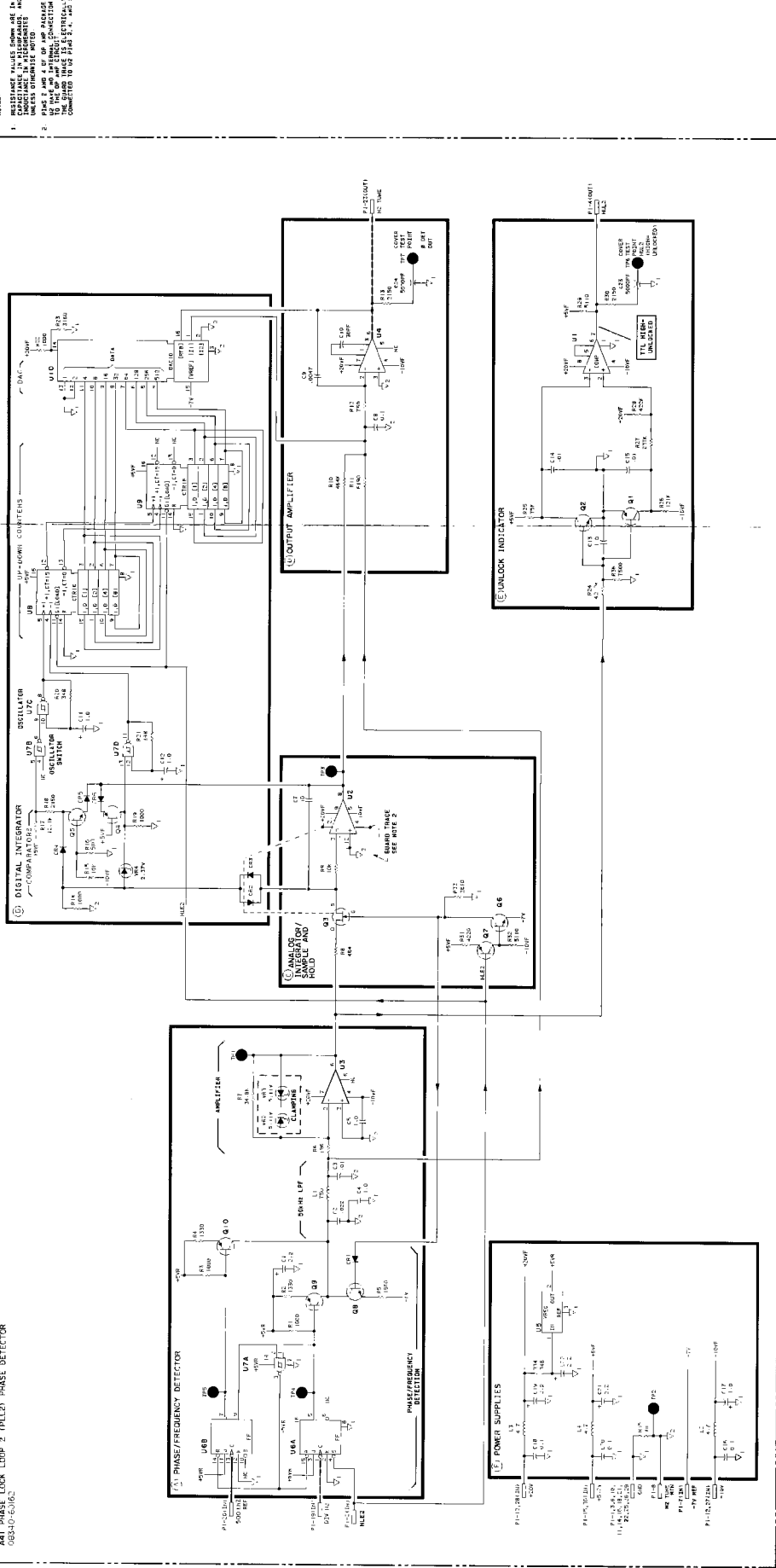

Figure A41-2. A41 PLL2 Phase Detector Schematic Diagram
20/30 Loops A41.7/A41.8

A41 PLL2 Phase Detector Component-Level Troubleshooting

Table A41-2. A41 PLL2 Phase Detector Replaceable Parts

Reference Designation	HP Part Number	C D	Qty	Description	Mfr Code	Mfr Part Number
A41	08340-60162	4	1	PLL2 PHASE DETECTOR ASSEMBLY	28480	08340-60162
A41C1	0180-0197	8	4	CAPACITOR-FXD 2.2UF ± 10% 20VDC TA	56289	150D225X9020A2
A41C2	0160-0574	3	1	CAPACITOR-FXD 022UF ± 20% 100VDC CER	28480	0160-0574
A41C3	0160-3879	7	3	CAPACITOR-FXD 01UF ± 20% 100VDC CER	28480	0160-3879
A41C4	0160-0127	2	2	CAPACITOR-FXD 1UF ± 20% 25VDC CER	28480	0160-0127
A41C5	0160-0127	2		CAPACITOR-FXD 1UF ± 20% 25VDC CER	28480	0160-0127
A41C6				NOT ASSIGNED		
A41C7	0160-5609	5	1	CAPACITOR-MPC 10.0 UF 50VDC	28480	0160-5609
A41C8	0160-4084	8	4	CAPACITOR-FXD 1UF ± 20% 50VDC CER	28480	0160-4084
A41C9	0160-0573	2	1	CAPACITOR-FXD 4700PF ± 20% 100VDC CER	28480	0160-0573
A41C10	0160-2199	2	1	CAPACITOR-FXD 30PF ± 5% 300VDC MICA	28480	0160-2199
A41C11	0180-0291	3	3	CAPACITOR-FXD 1UF ± 10% 35VDC TA	56289	150D105X9035A2
A41C12	0180-0291	3		CAPACITOR-FXD 1UF ± 10% 35VDC TA	56289	150D105X9035A2
A41C13	0160-4535	4	1	CAPACITOR-FXD 1UF ± 10% 50VDC CER	28480	0160-4535
A41C14	0160-3879	7		CAPACITOR-FXD 01UF ± 20% 100VDC CER	28480	0160-3879
A41C15	0160-3879	7		CAPACITOR-FXD 01UF ± 20% 100VDC CER	28480	0160-3879
A41C16	0160-4084	8		CAPACITOR-FXD 1UF ± 20% 50VDC CER	28480	0160-4084
A41C17	0180-0291	3		CAPACITOR-FXD 1UF ± 10% 35VDC TA	56289	150D105X9035A2
A41C18	0160-4084	8		CAPACITOR-FXD 1UF ± 20% 50VDC CER	28480	0160-4084
A41C19	0180-0197	8		CAPACITOR-FXD 2.2UF ± 10% 20VDC TA	56289	150D225X9020A2
A41C20	0160-4084	8		CAPACITOR-FXD 1UF ± 20% 50VDC CER	28480	0160-4084
A41C21	0180-0197	8		CAPACITOR-FXD 2.2UF ± 10% 20VDC TA	56289	150D225X9020A2
A41C22	0180-0197	8		CAPACITOR-FXD 2.2UF ± 10% 20VDC TA	56289	150D225X9020A2
A41C23	0160-2437	1	2	CAPACITOR-FDTHRU 5000PF +80 -20% 200V	28480	0160-2437
A41C24	0160-2437	1		CAPACITOR-FDTHRU 5000PF +80 -20% 200V	28480	0160-2437
A41CR1	1901-0033	2	2	DIODE-GEN PRP 180V 200MA DO-7	28480	1901-0033
A41CR2	1901-0376	6	2	DIODE-GEN PRP 35V 50MA DO-35	28480	1901-0376
A41CR3	1901-0376	6		DIODE-GEN PRP 35V 50MA DO-35	28480	1901-0376
A41CR4	1901-0033	2		DIODE-GEN PRP 180V 200MA DO-7	28480	1901-0033
A41CR5	1901-0033	2		DIODE-GEN PRP 180V 200MA DO-7	28480	1901-0033
A41CR6	1901-0033	2		DIODE-GEN PRP 180V 200MA DO-7	28480	1901-0033
A41L1	9100-1651	2	1	INDUCTOR RF-CH-MLD 750UH 5% 2DX 45LG	28480	9100-1651
A41L2	9140-0144	0	3	INDUCTOR RF-CH-MLD 4.7UH 10% 105DX 26LG	28480	9140-0144
A41L3	9140-0144	0		INDUCTOR RF-CH-MLD 4.7UH 10% 105DX 26LG	28480	9140-0144
A41L4	9140-0144	0		INDUCTOR RF-CH-MLD 4.7UH 10% 105DX 26LG	28480	9140-0144
A41MP1	2190-0009	4	2	WASHER-LK INTL T NO 8 168-IN-ID	28480	2190-0009
A41MP2	2190-0009	4		WASHER-LK INTL T NO 8 168-IN-ID	28480	2190-0009
A41MP3	2200-0101	0	2	SCREW-MACH 4-40 .188-IN-LG PAN-HD-POZI	00000	ORDER BY DESCRIPTION
A41MP4	2200-0101	0		SCREW-MACH 4-40 .188-IN-LG PAN-HD-POZI	00000	ORDER BY DESCRIPTION
A41MP5	2580-0002	4	2	NUT-HEX-DBL-CHAM 8-32-THD 085-IN-THK	00000	ORDER BY DESCRIPTION
A41MP6	2580-0002	4		NUT-HEX-DBL-CHAM 8-32-THD 085-IN-THK	00000	ORDER BY DESCRIPTION
A41MP7	08340-20087	8	1	COVER-PC 2 PHASE DETECTOR	28480	08340-20087
A41MP8	86701-40001	9	2	EXTRACTOR-PC BOARD	28480	86701-40001
A41MP9	86701-40001	9		EXTRACTOR-PC BOARD	28480	86701-40001
A41Q1	1853-0281	9	2	TRANSISTOR PNP 2N2907A SI TO-18 PD=400MW	04713	2N2907A
A41Q2	1854-0477	7	1	TRANSISTOR NPN 2N2222A SI TO-18 PD=500MW	04713	2N2222A
A41Q3	1855-0386	9	1	TRANSISTOR J-FET 2N4392 N-CHAN D-MODE	04713	2N4392
A41Q4	1853-0281	9	1	TRANSISTOR PNP 2N2907A SI TO-18 PD=400MW	02037	2N2907A
A41Q5	1854-0477	7	1	TRANSISTOR NPN 2N2222A SI TO-18 PD=500MW	02037	2N2222A
A41Q6	1854-0404	0	2	TRANSISTOR NPN SI TO-18 PD=360MW	28480	1854-0404
A41Q7	1853-0281	9		TRANSISTOR PNP 2N2907A SI TO-18 PD=400MW	04713	2N2907A
A41Q8	1854-0404	0		TRANSISTOR NPN SI TO-18 PD=360MW	28480	1854-0404
A41Q9	1853-0007	7	2	TRANSISTOR PNP 2N3251 SI TO-18 PD=360MW	04713	2N3251
A41Q10	1853-0007	7		TRANSISTOR PNP 2N3251 SI TO-18 PD=360MW	04713	2N3251
A41R1	0757-0280	3	5	RESISTOR 1K 1% 125W F TC=0 ± 100	24546	C4-1/8-T0-1001-F
A41R2	0757-0317	7	2	RESISTOR 1.33K 1% 125W F TC=0 ± 100	24546	C4-1/8-T0-1331-F
A41R3	0757-0280	3		RESISTOR 1K 1% 125W F TC=0 ± 100	24546	C4-1/8-T0-1001-F
A41R4	0757-0317	7		RESISTOR 1.33K 1% 125W F TC=0 ± 100	24546	C4-1/8-T0-1331-F
A41R5	0698-0083	8	1	RESISTOR 1.96K 1% 125W F TC=0 ± 100	24546	C4-1/8-T0-1961-F
A41R6	0698-3440	7	1	RESISTOR 196 1% 125W F TC=0 ± 100	24546	C4-1/8-T0-196R-F
A41R7	0757-0123	3	1	RESISTOR 34.8K 1% 125W F TC=0 ± 100	28480	0757-0123
A41R8	0698-0082	7	1	RESISTOR 464 1% 125W F TC=0 ± 100	24546	C4-1/8-T0-4640-F
A41R9	0757-0442	9	2	RESISTOR 10K 1% 125W F TC=0 ± 100	24546	C4-1/8-T0-1002-F
A41R10	0698-3260	9	1	RESISTOR 464K 1% 125W F TC=0 ± 100	28480	0698-3260

A41 PLL2 Phase Detector Component-Level Troubleshooting

Table A41-2. A41 PLL2 Phase Detector Replaceable Parts

Reference Designation	HP Part Number	C	D	Qty	Description	Mfr Code	Mfr Part Number
A41R11	0757-0290	5	1		RESISTOR 8.19K 1% .125W F TC=0±100	19701	MF4C1/8-T0-6191-F
A41R12	0757-0420	3	1		RESISTOR 750 1% .125W F TC=0±100	24546	C4-1/8-T0-751-F
A41R13	0698-0084	9	3		RESISTOR 2.15K 1% .125W F TC=0±100	24546	C4-1/8-T0-2151-F
A41R14	0757-0280	3			RESISTOR 1K 1% .125W F TC=0±100	24546	C4-1/8-T0-1001-F
A41R15	0757-0442	9			RESISTOR 10K 1% .125W F TC=0±100	24546	C4-1/8-T0-1002-F
A41R16	0757-0438	3	1		RESISTOR 5.11K 1% .125W F TC=0±100	24546	C4-1/8-T0-5111-F
A41R17	0757-0444	1	1		RESISTOR 12.1K 1% .125W F TC=0±100	24546	C4-1/8-T0-1212-F
A41R18	0698-0084	9			RESISTOR 2.15K 1% .125W F TC=0±100	24546	C4-1/8-T0-2151-F
A41R19	0757-0280	3			RESISTOR 1K 1% .125W F TC=0±100	24546	C4-1/8-T0-1001-F
A41R20	0698-3445	2	3		RESISTOR 348 1% .125W F TC=0±100	24546	C4-1/8-T0-348R-F
A41R21	0698-3445	2			RESISTOR 348 1% .125W F TC=0±100	24546	C4-1/8-T0-348R-F
A41R22	0757-0290	3			RESISTOR 1K 1% .125W F TC=0±100	24546	C4-1/8-T0-1001-F
A41R23	0757-0279	0	1		RESISTOR 3.16K 1% .125W F TC=0±100	24546	C4-1/8-T0-3161-F
A41R24	0698-3450	9	1		RESISTOR 42.2K 1% .125W F TC=0±100	24546	C4-1/8-T0-4222-F
A41R25	0757-0482	3	1		RESISTOR 75K 1% .125W F TC=0±100	24546	C4-1/8-T0-7502-F
A41R26	0757-0467	8	1		RESISTOR 121K 1% .125W F TC=0±100	24546	C4-1/8-T0-1213-F
A41R27	0698-3266	5	1		RESISTOR 237K 1% .125W F TC=0±100	24546	C4-1/8-T0-2373-F
A41R28	0698-3480	1	1		RESISTOR 422K 1% .125W F TC=0±100	28480	0698-3480
A41R29	0757-0438	3	2		RESISTOR 5.11K 1% .125W F TC=0±100	24546	C4-1/8-T0-5111-F
A41R30	0698-0084	9			RESISTOR 2.15K 1% .125W F TC=0±100	24546	C4-1/8-T0-2151-F
A41R31	0698-3154	0	1		RESISTOR 4.22K 1% .125W F TC=0±100	24546	C4-1/8-T0-4221-F
A41R32	0757-0438	3			RESISTOR 5.11K 1% .125W F TC=0±100	24546	C4-1/8-T0-5111-F
A41R33	0698-0085	0	1		RESISTOR 2.61K 1% .125W F TC=0±100	24546	C4-1/8-T0-2611-F
A41R34	0698-3445	2			RESISTOR 348 1% .125W F TC=0±100	24546	C4-1/8-T0-348R-F
A41R35	0757-0346	2	1		RESISTOR 10 1% .125W F TC=0±100	24546	C4-1/8-T0-10R0-F
A41R36	0757-0440	7	1		RESISTOR 7.5K 1% .125W F TC=0±100	24546	C4-1/8-T0-7501-F
A41TP1	0380-0535	0	5		TERMINAL TEST POINT PCB	00000	ORDER BY DESCRIPTION
A41TP2	0380-0535	0			TERMINAL TEST POINT PCB	00000	ORDER BY DESCRIPTION
A41TP3	0380-0535	0			TERMINAL TEST POINT PCB	00000	ORDER BY DESCRIPTION
A41TP4	0380-0535	0			TERMINAL TEST POINT PCB	00000	ORDER BY DESCRIPTION
A41TP5	0380-0535	0			TERMINAL TEST POINT PCB	00000	ORDER BY DESCRIPTION
A41U1	1826-0026	3	1		IC COMPARATOR PRCN TO-99 PKG	01295	LM311L
A41U2	1826-0459	6	1		IC OP AMP 14-DIP-C PKG	27014	LH0042CD
A41U3	1826-0471	2	1		IC OP AMP LOW-DRIFT TO-99 PKG	28480	1826-0471
A41U4	1826-0059	2	1		IC OP AMP GP TO-99 PKG	01295	LM201AL
A41U5	1820-0429	8	1		IC V RGLTR TO-39	18324	LM309H
A41U6	1820-1212	9	1		IC FF TTL LS J-K NEG-EDGE-TRIG	01295	SN74LS112AN
A41U7	1820-1425	6	1		IC SCHMITT-TRIG TTL LS NAND QUAD 2-INP	01295	SN74LS132N
A41U8	1820-1194	6	2		IC CNTR TTL LS BIN UP/DOWN SYNCHRO	01295	SN74LS193N
A41U9	1820-1194	6			IC CNTR TTL LS BIN UP/DOWN SYNCHRO	01295	SN74LS193N
A41U10	1826-0448	3	1		IC-7533C P1 DAC	24355	AD7520LN(SEL)
A41VR1					NOT ASSIGNED		
A41VR2	1902-0041	4	2		DIODE-ZNR 5.11V 5% DO-35 PD= 4W	28480	1902-0041
A41VR3	1902-0041	4			DIODE-ZNR 5.11V 5% DO-35 PD= 4W	28480	1902-0041
A41VR4	1902-3002	3	1		DIODE-ZNR 2.37V 5% DO-7 PD= 4W TC=-.074%	28480	1902-3002

A42 Phase Lock Loop 2 Divider Circuit Description

ASSEMBLY PURPOSE

The PLL2 divider board performs two functions:

- It generates the 500 kHz reference signal which is used by the PLL2 phase detector assembly by dividing the 10 MHz crystal reference oscillator by 20. This function is performed in block D.
- It divides the PLL2 VCO output signal (which can be between 100 and ≤ 150 MHz) by a micro-processor-selected number between 200.01 and 300. The divider output is a 500 kHz signal. All circuit blocks except block D are used to perform this function.

The two signals above are sent to the A41 PLL2 phase detector assembly and phase-lock the PLL2 loop.

Refer to Figure A42-1 for a simplified block diagram of this circuitry.

Refer to the Frequency Range and CW Mode Accuracy performance test for use as a troubleshooting aid.

LATCHES (BLOCK A)

The three latches in this block store the BCD (Binary Coded Decimal) numbers that are used to preset the counters on the PLL2 divider assembly. The schematic (Figure A42-4) shows the relationship of each output line to the frequency of the PLL2 VCO. The frequency of the VCO can be determined by adding the total of each individual output's contribution (if the output is high) and subtracting that total from 150 MHz. For example, if U14 pin 10 and U14 pin 2 are both high and all the other outputs of U14, U2, and U13 were low, the total contribution would be $40 \text{ MHz} + 5 \text{ MHz} = 45 \text{ MHz}$. The frequency of the PLL2 VCO would then be $150 - 45 = 105 \text{ MHz}$.

U14 pin 12 (SW1) and U14 pin 15 (SW2), are control lines which are routed to the PLL2 VCO.

REFERENCE DIVIDER (BLOCK D)

A 10 MHz signal derived from the A51 reference oscillator is amplified and used to drive divider U4. The divide-by-ten output of U4 drives U16, whose divide by 2 output goes to the A41 PLL2 phase detector. The 500 kHz output is a reference signal which is compared to the programmable divide output of the PLL2 divider. The TTL input on P1-2 (HLE2) disables the reference divider during sweeps.

FRACTIONAL DIVIDE CIRCUITRY

Five of the A42 assembly's circuit blocks form a programmable fractional divider. The circuit blocks are listed below:

- Prescaler (block E)
- Direct Divider (block B)
- Integer Counter (block F)
- Fractional Counter (block C)
- Synchronizer (block G)

PRESCALER (BLOCK E)

The -18 dBm, 75-150 Mhz input from A40 PLL2 VCO is amplified by Q1 and used to drive prescaler U1A. The prescaler is a selectable divide-by-ten or divide-by-eleven circuit. If the LSWALLOW line is low, the device is in the divide-by-eleven mode; i.e. it takes eleven input pulses to produce one output pulse. If the LSWALLOW line is high (divide-by-ten mode), then it requires ten input pulses to produce one output pulse. The divide-by-eleven mode can be described as a pulse swallowing mode — it requires one more pulse than the divide-by-ten mode to produce the same output pulse. The output of the prescaler is converted to TTL signal levels by U1B and is buffered by U9C. This signal is the clock signal for all the other circuits of the fractional divider.

DIRECT DIVIDE (BLOCK B)

The direct divide block contains two presettable counters followed by two flip flops. The direct divide block determines the number of clock pulses in a cycle. A cycle is the time from one LRESET pulse to the next. The output at TP1 is the divided output signal. The other output signal from this block is the LRESET signal. The frequency of the divided output signal (and the LRESET pulse) is always 500 kHz (when the PLL2 loop is locked). The divider output is phase-locked to the 500 kHz reference signal. The frequency of the input signal (PLL2 VCO output) changes as the divide number is changed.

The two counters operate together as a single unit. U15 is fixed at a preset of zero and is the most significant digit. When the output of the counter block equals 25, U9B produces a high output. If the U8 counter is preset to zero, it will take 25 full clock cycles to output a value of 25 to U9B. If U8 is preset to some number (for example, four), the counter begins counting with the number five, and only needs 21 clock pulses before the value 25 is output to U9B.

With a value of 25 on its input, U9B outputs a TTL high for one clock pulse. Four clock pulses after the output U9B goes high, the two flip-flops generate the LRESET pulse.

To sum up the total number of clock cycles required to generate an output pulse to LRESET (TP1) = $25 - (\text{preset number}) + 4$.

INTEGER COUNTER (BLOCK F)

The integer counter consists of a presettable counter and a NAND gate. The purpose of the integer counter block is to control the number of clock cycles that the prescaler will be in the "pulse swallow" (divide-by-eleven) mode.

FRACTIONAL COUNTER (BLOCK C)

The fractional counter provides noninteger divide numbers. The fractional counter block contains two rate multipliers and a one-shot multivibrator. The rate multipliers are enabled through U2D and the control line HLE2. A high on HLE2 enables the rate multipliers. The rate multipliers are clocked by the divided output signal, DIV N2. The output of this block is STOP SWALLOW EARLY. When STOP SWALLOW EARLY goes high, the synchronizer (block G) bypasses the normal routing of the integer counter output and forces LSWALLOW high one clock pulse earlier than usual. For the cycle that STOP SWALLOW EARLY is high, one less input pulse is required to produce the same output pulse. The one shot holds STOP SWALLOW EARLY high for about 1.6 microseconds (when triggered by rate multiplier U5) so that the SYNCHRONIZER will respond properly.

SYNCHRONIZER (BLOCK G)

The synchronizer controls the divide factor of the prescaler (ten or eleven) by changing the state of the LSWALLOW line. The two divide factors, when used in combination, provide the different divide values needed for the operation of the this assembly.

LSWALLOW is switched high and low by the LRESET signal. setting the prescaler divide factor to either ten or eleven. Every cycle begins with the LRESET line high. In this state the LSWALLOW output is low, setting the prescaler divisor to eleven.

The LRESET line going low causes U3A pin 6 to go high and LSWALLOW to go high, setting the prescaler divisor to ten. LRESET stays low for two clock pulses.

The next CLOCK pulse after LRESET goes high causes the U3A pin 6 output (through U2B) to change the state of U3B, setting the LSWALLOW line low. Thus every cycle starts (one clock pulse after LRESET) with LSWALLOW low and the prescaler in the divide-by-eleven mode.

U2A and U2B serve to route the STOP SWALLOW signal around U3A when the STOP SWALLOW EARLY line is high. This causes U3B pin 9 to go high one clock pulse earlier than usual.

A42 PLL2 Divider Circuit Description

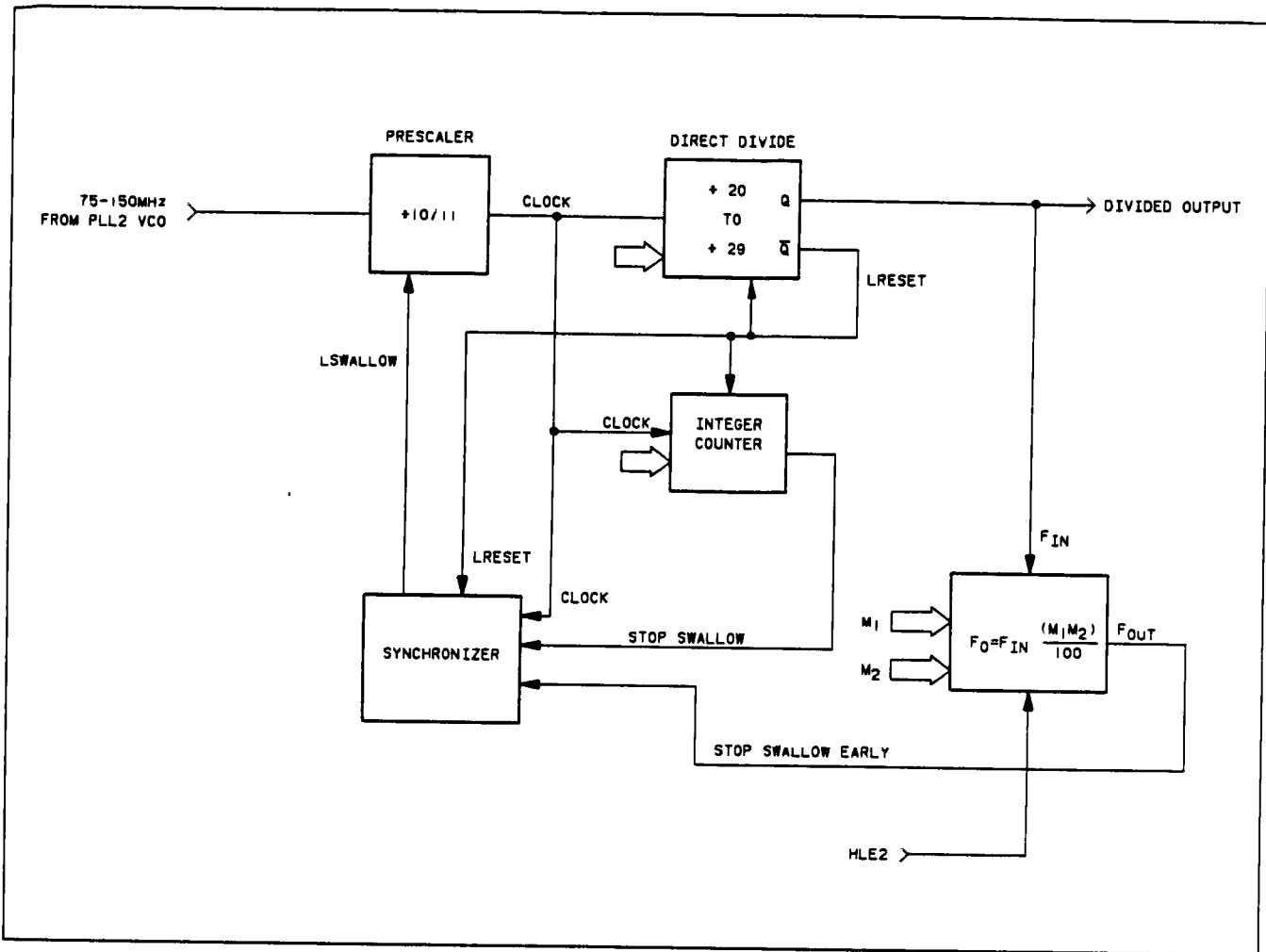

Figure A42-1. PLL2 Divider Simplified Block Diagram

A42 PLL2 Divider Circuit Description

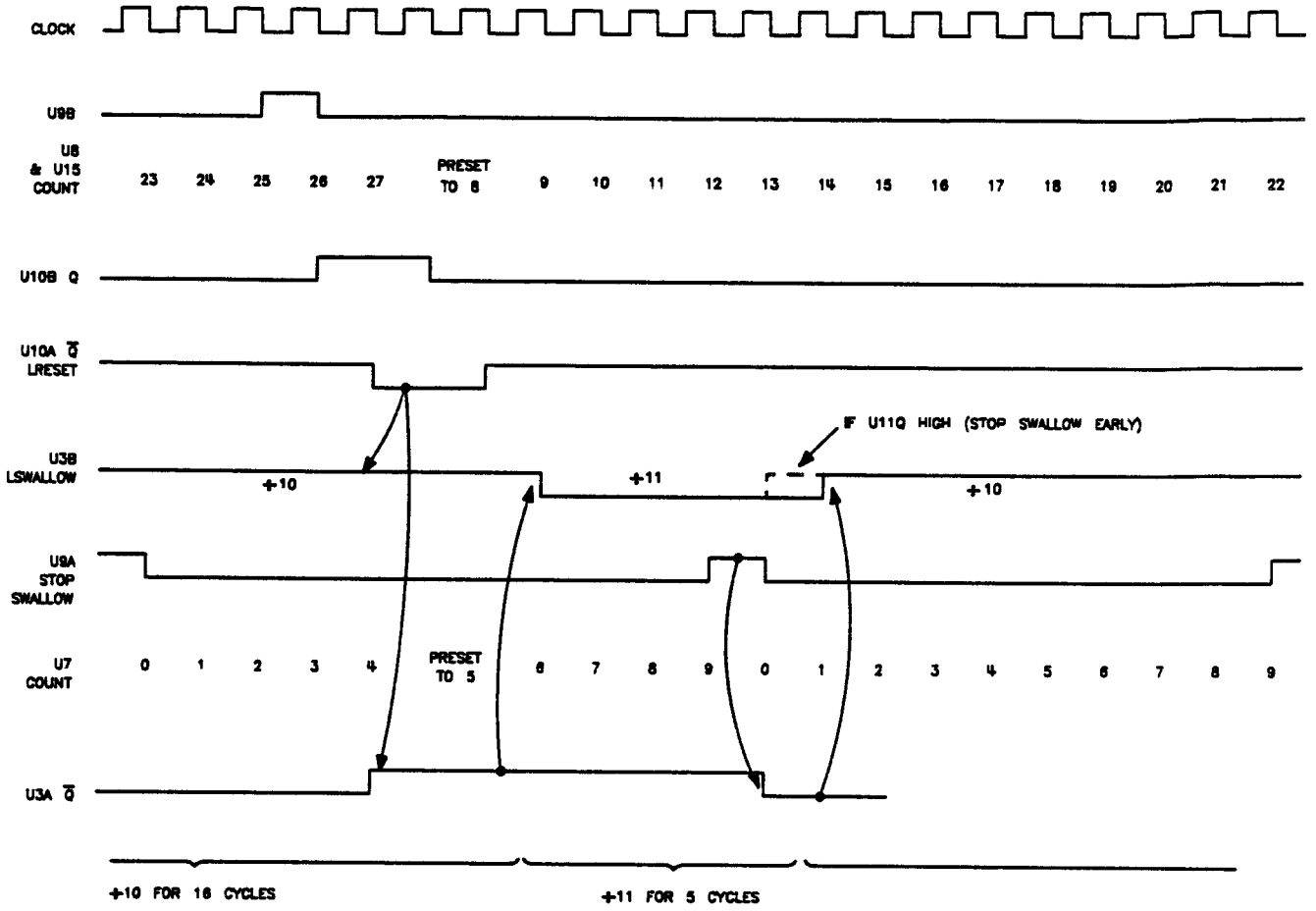

Figure A42-2. Partial Circuit Timing for divide by 215 Example

A42 PLL2 Divider Component-Level Troubleshooting

Table A42-1. A42 PLL2 Divider Pin I/O

Pin	Mnemonic	Levels	Source	Destination
1 19	LCK2 LCK1	TTL (LOW TRUE) TTL (LOW TRUE)	XA59P1-109 XA59P1-54	A A
2 20	HLE2 GND	TTL (HIGH TRUE) 0V	XA59P1-53 A62 STAR GND	*C D *H
3 21	DB1 DB0	TTL TTL	XA60P1-76 XA60P1-20	*A *A
4 22	DB3 DB2	TTL TTL	XA60P1-77 XA60P1-21	*A *A
5 23	DB5 DB4	TTL TTL	XA60P1-78 XA60P1-22	*A *A
6 24	DB7 DB6	TTL TTL	XA60P1-79 XA60P1-23	*A *A
7 25	DB9 DB8	TTL TTL	* *	*A *A
8 26	DB11 DB10	TTL TTL	* *	*A *A
9 27	500 KHZ REF DIV N2	TTL TTL (LOW TRUE)	D B	XA41P1-20 *C
10 28	GND GND	0V 0V	A62 STAR GND A62 STAR GND	*H *H
11 29				
12 30				
13 31				
14 32	SW2 SW1	TTL TTL	A A	XA40P1-22 *
15 33	-10V -10V	-10V -10V	XA53P1-12, 13, 31, 32 XA53P1-12, 13, 31, 32	*NOT USED *NOT USED
16 34	+20V +20V	+20V +20V	XA5201-16, 40 XA52P1-16, 40	*NOT USED *NOT USED
17 35	GND GND	0V 0V	A62 STAR GND A62 STAR GND	*H *H
18 36	+5.2V +5.2V	+5.2V +5.2V	XA52P1-17, 18, 41, 42 XA5201-17, 18, 41, 42	*H *H

A single letter in the source or destination column refers to a function block on this assembly schematic.

An asterisk (*) denotes multiple sources or destinations; refer to the A62 motherboard wiring list for a complete representation of signal sources and destinations.

A42 PLL2 Divider Component-Level Troubleshooting

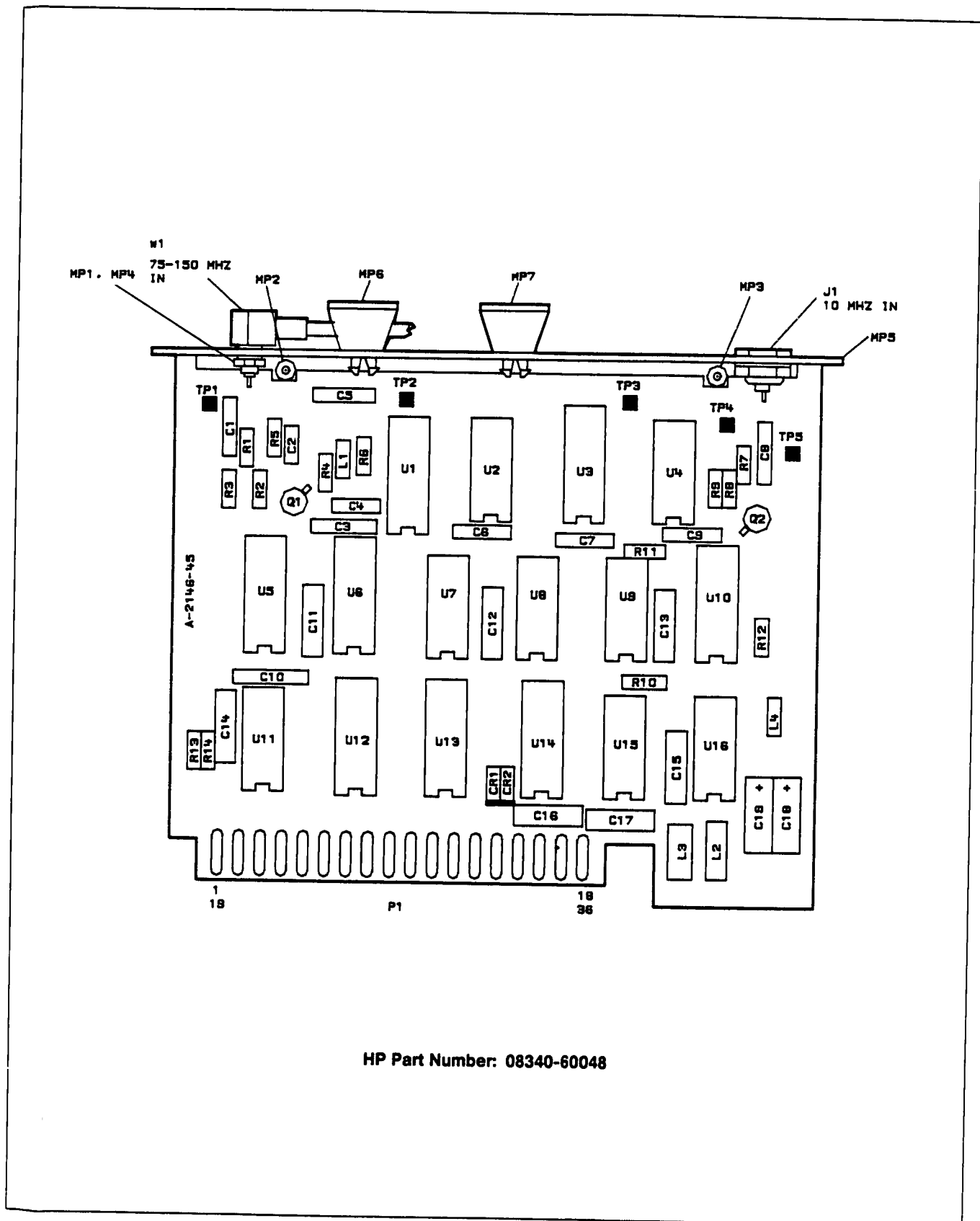

Figure A42-3. A42 PLL2 Divider Component Location Diagram

- NOTES:
1. RESISTANCE VALUES SHOWN ARE IN OHMS, UNLESS OTHERWISE NOTED.
 2. J1, AND J2 CENTER CONDUCTORS ARE ELECTRICALLY CONNECTED TO THE PC BOARD GROUND THROUGH THE CENTER PIN OF THE CONNECTORS. THEIR OUTER CONDUCTORS ARE ELECTRICALLY CONNECTED TO THE PC BOARD GROUND THROUGH THE CENTER CONDUCTORS THROUGH THE ASSEMBLY COVER PLATE.

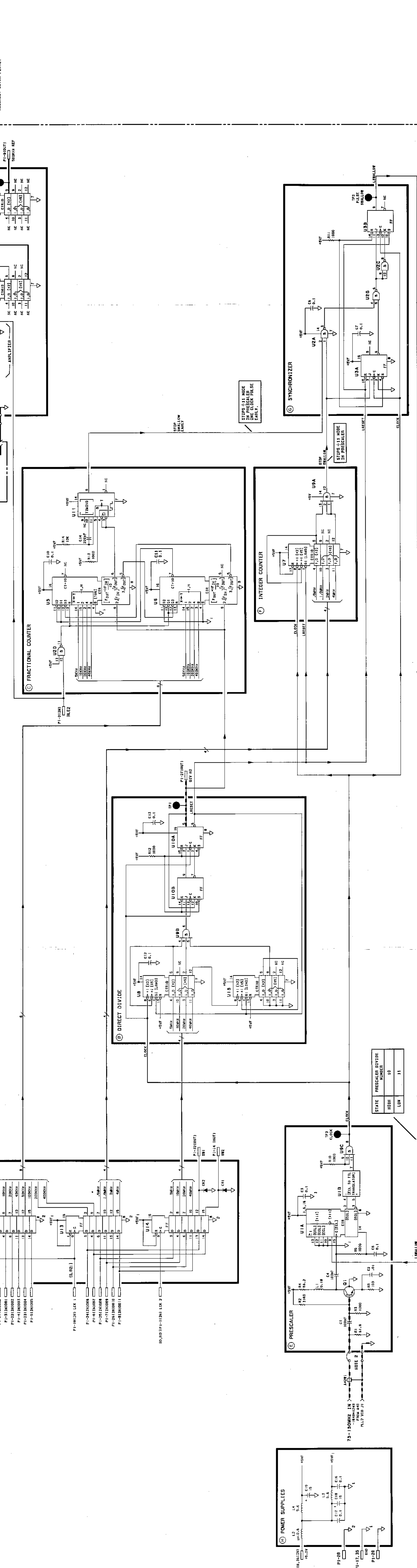

Figure A42-4. A42 PLL2 Divider Schematic Diagram

A42 PLL2 Divider Component-Level Troubleshooting

Table A42-2. A42 PLL2 Divider Replaceable Parts

Reference Designation	HP Part Number	C D	Qty	Description	Mfr Code	Mfr Part Number
A42	08340-60048	5	1	PPL2 DIVIDER ASSEMBLY	28480	08340-60048
A42C1	0160-3877	5	2	CAPACITOR-FXD 100PF ±20% 200VDC CER	28480	0160-3877
A42C2	0160-3879	7	2	CAPACITOR-FXD 01UF ±20% 100VDC CER	28480	0160-3879
A42C3	0160-4084	8	12	CAPACITOR-FXD 1UF ±20% 50VDC CER	28480	0160-4084
A42C4	0160-3877	5		CAPACITOR-FXD 100PF ±20% 200VDC CER	28480	0160-3877
A42C5	0160-4084	8		CAPACITOR-FXD 1UF ±20% 50VDC CER	28480	0160-4084
A42C6	0160-4084	8		CAPACITOR-FXD 1UF ±20% 50VDC CER	28480	0160-4084
A42C7	0160-4084	8		CAPACITOR-FXD 1UF ±20% 50VDC CER	28480	0160-4084
A42C8	0160-3879	7		CAPACITOR-FXD 01UF ±20% 100VDC CER	28480	0160-3879
A42C9	0160-4084	8		CAPACITOR-FXD 1UF ±20% 50VDC CER	28480	0160-4084
A42C10	0160-4084	8		CAPACITOR-FXD 1UF ±20% 50VDC CER	28480	0160-4084
A42C11	0160-4084	8		CAPACITOR-FXD 1UF ±20% 50VDC CER	28480	0160-4084
A42C12	0160-4084	8		CAPACITOR-FXD 1UF ±20% 50VDC CER	28480	0160-4084
A42C13	0160-4084	8		CAPACITOR-FXD 1UF ±20% 50VDC CER	28480	0160-4084
A42C14	0160-0570	9	1	CAPACITOR-FXD 220PF ±20% 100VDC CER	20932	5024EM100RD221M
A42C15	0160-4084	8		CAPACITOR-FXD 1UF ±20% 50VDC CER	28480	0160-4084
A42C16	0160-4084	8		CAPACITOR-FXD 1UF ±20% 50VDC CER	28480	0160-4084
A42C17	0160-4084	8		CAPACITOR-FXD 1UF ±20% 50VDC CER	28480	0160-4084
A42C18	0180-1746	5	2	CAPACITOR-FXD 15UF ±10% 20VDC TA	56289	150D156X9020B2
A42C19	0180-1746	5		CAPACITOR-FXD 15UF ±10% 20VDC TA	56289	150D156X9020B2
A42CR1	1901-0743	1	2	DIODE-PWR RECT 1N4004 400V 1A DO-41	01295	1N4004
A42CR2	1901-0743	1		DIODE-PWR RECT 1N4004 400V 1A DO-41	01295	1N4004
A42J1	1250-0544	9	1	CONNECTOR-RF MALE SMB	28480	1250-0544
A42L1	9100-2250	9	1	INDUCTOR RF-CH-MLD 180NH 10% 105DX 26LG	28480	9100-2250
A42L2	9100-1788	6	1	CHOKE-WIDE BAND ZMAX=680 OHM@ 180 MHZ	02114	VK200 20/48
A42L3	9100-1618	1	2	INDUCTOR RF-CH-MLD 5.6UH 10%	28480	9100-1618
A42L4	9100-1618	1		INDUCTOR RF-CH-MLD 5.6UH 10%	28480	9100-1618
A42MP1	2190-0124	4	1	WASHER-LK INTL T NO. 10 195-IN-ID	28480	2190-0124
A42MP2	2200-0101	0	2	SCREW-MACH 4-40 188-IN-LG PAN-HD-POZI	00000	ORDER BY DESCRIPTION
A42MP3	2200-0101	0		SCREW-MACH 4-40 188-IN-LG PAN-HD-POZI	00000	ORDER BY DESCRIPTION
A42MP4	2950-0078	9	1	NUT-HEX-DBL-CHAM 10-32-THD 067-IN-THK	28480	2950-0078
A42MP5	08340-20088	9	1	COVER-PC PLL2 DRIVER	28480	08340-20088
A42MP6	86701-40001	9	2	EXTRACTOR-PC BOARD	28480	86701-40001
A42MP7	86701-40001	9		EXTRACTOR-PC BOARD	28480	86701-40001
A42Q1	1854-0546	1	1	TRANSISTOR NPN SI TO-72 PD=200MW	28480	1854-0546
A42Q2	1854-0019	3	1	TRANSISTOR NPN SI TO-18 PD=360MW	28480	1854-0019
A42R1	0757-0276	7	1	RESISTOR 81 9 1% 125W F TC=0±100	24546	C4-1/8-T0-6192-F
A42R2	0757-0279	0	1	RESISTOR 3 16K 1% 125W F TC=0±100	24546	C4-1/8-T0-3161-F
A42R3	0757-0280	3	7	RESISTOR 1K 1% 125W F TC=0±100	24546	C4-1/8-T0-1001-F
A42R4	0757-0395	1	1	RESISTOR 56 2 1% 125W F TC=0±100	24546	C4-1/8-T0-56R2-F
A42R5	0757-0401	0	1	RESISTOR 100 1% 125W F TC=0±100	24546	C4-1/8-T0-101-F
A42R6	0757-0280	3		RESISTOR 1K 1% 125W F TC=0±100	24546	C4-1/8-T0-1001-F
A42R7	0698-3444	1	1	RESISTOR 316 1% 125W F TC=0±100	24546	C4-1/8-T0-316R-F
A42R8	0698-3157	3	1	RESISTOR 19 6K 1% 125W F TC=0±100	24546	C4-1/8-T0-1962-F
A42R9	0757-0280	3		RESISTOR 1K 1% 125W F TC=0±100	24546	C4-1/8-T0-1001-F
A42R10	0757-0280	3		RESISTOR 1K 1% 125W F TC=0±100	24546	C4-1/8-T0-1001-F
A42R11	0757-0280	3		RESISTOR 1K 1% 125W F TC=0±100	24546	C4-1/8-T0-1001-F
A42R12	0757-0280	3		RESISTOR 1K 1% 125W F TC=0±100	24546	C4-1/8-T0-1001-F
A42R13	0757-0280	3		RESISTOR 1K 1% 125W F TC=0±100	24546	C4-1/8-T0-1001-F
A42R14	0757-0442	9	1	RESISTOR 10K 1% 125W F TC=0±100	24546	C4-1/8-T0-1002-F
A42TP1	0360-0535	0	5	TERMINAL TEST POINT PCB	00000	ORDER BY DESCRIPTION
A42TP2	0360-0535	0		TERMINAL TEST POINT PCB	00000	ORDER BY DESCRIPTION
A42TP3	0360-0535	0		TERMINAL TEST POINT PCB	00000	ORDER BY DESCRIPTION
A42TP4	0360-0535	0		TERMINAL TEST POINT PCB	00000	ORDER BY DESCRIPTION
A42TP5	0360-0535	0		TERMINAL TEST POINT PCB	00000	ORDER BY DESCRIPTION
A42U1	1820-1888	5	1	IC PRESCR ECL	04713	MC12013L
A42U2	1820-0681	4	1	IC GATE TTL S NAND QUAD 2-INP	01295	SN74S00N
A42U3	1820-0629	0	2	IC FF TTL S J-K NEG-EDGE-TRIG	01295	SN74S112N
A42U4	1820-1251	6	5	IC CNTR TTL LS DECD ASYNCHRO	01295	SN74LS196N
A42U5	1820-0909	9	2	IC MULTR TTL	01295	SN74167N
A42U6	1820-0909	9		IC MULTR TTL	01295	SN74167N
A42U7	1820-1251	6		IC CNTR TTL LS DECD ASYNCHRO	01295	SN74LS196N
A42U8	1820-1251	6		IC CNTR TTL LS DECD ASYNCHRO	01295	SN74LS196N
A42U9	1820-0686	9	1	IC GATE TTL S AND TPL 3-INP	01295	SN74S111N
A42U10	1820-0629	0		IC FF TTL S J-K NEG-EDGE-TRIG	01295	SN74S112N

A42 PLL2 Divider Component-Level Troubleshooting

Table A42-2. A42 PLL2 Divider Replaceable Parts

Reference Designation	HP Part Number	C D	Qty	Description	Mfr Code	Mfr Part Number
A42U11	1820-0261	6	1	IC MV TTL MONOSTBL	01295	SN74121N
A42U12	1820-1196	8	3	IC FF TTL LS D-TYPE POS-EDGE-TRIG COM	01295	SN74LS174N
A42U13	1820-1196	8		IC FF TTL LS D-TYPE POS-EDGE-TRIG COM	01295	SN74LS174N
A42U14	1820-1196	8		IC FF TTL LS D-TYPE POS-EDGE-TRIG COM	01295	SN74LS174N
A42U15	1820-1251	6		IC CNTR TTL LS DECD ASYNCHRO	01295	SN74LS196N
A42U16	1820-1251	6		IC CNTR TTL LS DECD ASYNCHRO	01295	SN74LS196N
A42W1	08340-60111	3	1	CABLE ASSEMBLY-A42	28480	08340-60111

A43 Phase Lock Loop 2 Discriminator Circuit Description

ASSEMBLY PURPOSE

The A43 PLL2 Discriminator adjusts the frequency of the VCO to eliminate phase errors. The discriminator is given a phase-error voltage by the A41 PLL2 phase detector. The following signals are summed together by the discriminator to control VCO frequency:

- **PRETUNE** — The microprocessor-controlled pretune DAC generates PRETUNE, which provides coarse-tuning of the VCO in 50 kHz steps.
- **20-30 SWEEP RAMP** — The 0 to 10V sweep ramp is generated on the A58 sweep generator.
- The phase-error voltage from the A41 PLL2 phase detector (mentioned above).
- **Analog Feedback from the A40 PLL2 VCO.**

The method used to combine these signals is to mix all input currents together at the input of an integrator (junction of R43 in the summing amplifier, block F, and R40 in pretune, block D). If the voltage at this node is not zero, then the integrator output will change, forcing the PLL2 VCO to a different frequency. The frequency continues to change until the discriminators output current to the summing node produces zero volts. This forms a frequency-locked loop, with the discriminator as the feedback element. The result is the equivalent of having a very linear VCO. (See Figure A43-1).

The output of the summing amplifier controls a current source which produces 1 to 9mA of current to tune the A40 PLL2 VCO.

This discriminator-linearized-VCO is used inside a phase lock loop. In this configuration the phase lock loop tunes the VCO indirectly, by changing the gain of the discriminator. The phase lock loop fine tunes the discriminator before start-of-sweep phase lock (of the YIG oscillator) occurs, providing an accurate synthesized start frequency. To sweep the loop, the discriminators fine tune voltage is stored in a sample and hold circuit, and the phase-lock loop is opened. This establishes an accurate, synthesized start frequency for the sweep and calibrates the discriminator gain. The current summing node is still forced to 0 volts, so when a current ramp is injected into the node, the discriminator output current decreases, causing the VCO to ramp in frequency and cancel the injected current. The discriminator remains active at all times. The discriminator has the greatest effect on sweep linearity, while the PLL2 VCO has very little effect.

The discriminator itself is formed by two of the blocks of the A43 circuit; the pulse generator (block A) and the current source (block B). The input to the discriminator is used to trigger a very stable 1.6 microsecond pulse. The current source is activated by this pulse, and outputs a fixed amount of current for 1.6 microseconds. These current pulses are averaged to produce a current flow that is proportional to the frequency of the input to the discriminator; the higher the frequency, the more frequent the 1.6 microsecond pulses, and the greater the average current. The gain of the discriminator (current out/frequency in) can be adjusted by changing the amount of current flow, but the duration will always be a constant 1.6 microseconds.

The sensitivity of the discriminator is adjusted by control signal N2 Tune into current source (block B) from the A41 PLL2 phase detector.

PULSE GENERATOR (BLOCK A)

The pulse generator functions as a one shot multivibrator. The signal at TP2 is a 1.6 microsecond pulse, with a repetition rate equivalent to the input frequency. This signal will be integrated in the current source (block B) to produce an average current that is proportional to the input frequency. The 150 to 300 kHz (ECL level) input from the A40 PLL2 VCO assembly is amplified and level shifted by Q6 and Q7. At the beginning of a cycle both inputs to U7D are low. When the collector of Q7 goes high, U7D output goes low, saturating Q11 and causing resonator L4, C15, and C16 to ring at 5.2 MHz. This damped oscillation appears at the collector of Q9, is clipped by Q10, and used to drive counter U6.

Q10 is a comparator. The signal appears across L5, driving the base of Q10A and Q10B in opposite directions. U6 is preset to a count of six. When the count reaches eight, U6 pin 7 goes high. This is fed back to U7D pin 11, holding its output low. After 1.6 microseconds, the count reaches 16, U6 pin 7 goes low again, U7D output goes high turning Q11 off. This results in the resonance being damped by R17. At the count of 16, U7C and U7B reset the counter to five. Before the oscillation is fully damped, the counter gets clocked to six. U6 should always be reset to either five or six depending upon how quickly Q11 can dampen the resonator. The actual number is not critical, since the pulse output starts at the count of eight, ignoring the first pulses, and the width will always be a constant 1.6 microseconds.

U7D output going low starts the resonator ringing. If the counter did not reach an eight count, U7D output would be held low causing an incorrect condition. When U7D output is high, U7A output turns CR1 on, discharging C14. When the output of U7D goes low, CR1 is reversed biased and C14 starts to charge through U6 pin 14 until the U6 input circuit trips. This resets U6 and prevents an incorrect condition.

The pulse width at TP2 should be equivalent to eight pulses at TP3.

CURRENT SOURCE (BLOCK B)

With the tuning voltage input (P1 pin 28) at zero volts, the voltage divider from $-7V$ through R6, Q3A/B, and R7 to $+20V$ sets the input of U4 pin 3 to about $+13V$. U4 and Q4 form a voltage controlled current source, where the amount of the current flowing out of Q4 drain is proportional to the voltage on U4 pin 3. The ratio of current to voltage is set by R9 (.3 MHz Adjust). The output of the current source flows through Q5A when U6 pin 7 (block A) is low. If an input pulse has triggered the pulse generator, the current is switched through Q5B for 1.6 microseconds. Since Q4 and its associated circuit form a constant current source, when Q5A is on all the current flows through Q5A, leaving no current for Q5B. When Q5A is shut off all the current flows through Q5B. Q5B current is integrated by C20 and goes through a low-pass filter to the summing point of the discriminator loop. The average value of this current is directly proportional to the input frequency (about 1.5 mA at 0.3 MHz). The 0.3 MHz Adjust (R9) in the U4 feedback loop adjusts the the discriminator gain by changing the amount of current flow during the 1.6 microsecond current pulses.

The tuning voltage input (N2 Tune) from the A41 PLL2 phase detector (P1 pin 28) is also able to adjust the gain of the discriminator by $\pm 1\%$ by changing the voltage at U4 pin 3. This changes the amount of current flow during the 1.6 microsecond current surges.

C21 stabilizes the two grounds when Q5A/B is switching.

–7V SUPPLY (BLOCK C)

U13 maintains a constant current through reference diode CR1. R35 sets this current to approximately 7.7mA. The 6.3V reference is amplified due to the ratio of R33 and R34 to yield –7V. Q8 provides a low impedance, high current output.

PRETUNE (BLOCK D)

The pretune circuit tunes the discriminator loop so that the PLL2 VCO output will approximate the desired frequency. The phase lock loop then applies small corrections to the discriminator, which tunes the PLL2 VCO to the precise frequency required. The A60 processor outputs a 10-bit binary word representing the pretune frequency and then strobes the data into latches U9 and U12. This data programs DAC U11, whose output goes to U10. If the input to the DAC is all zeros, the output of U10 is 0 volts. The 1.5 mA into the summing node must then come entirely from the discriminator (sweep ramp = 0).

1.5 mA out of the discriminator corresponds to 0.3 MHz into the discriminator. To pretune the input frequency to 200 kHz, a binary word representing decimal 1000 is programmed into the the DAC U11. This results in +6.84V at TP1 and a corresponding current into the summing node (through R41 and R42) of 0.5mA. Adding 0.5mA to the summing node causes the discriminator output current to equal $1.5 - 0.5 = 1.0$ mA, which corresponds to a discriminator input frequency of 0.2MHz. R41 (0.2 MHz Adjust) is used to adjust the VCO frequency to 100 MHz which in turn sets the discriminator input frequency to 0.2 MHz (100 MHz/500). R41 (0.2 MHz Adjust) and R9 (0.3 MHz Adjust) function as slope and offset adjustments to calibrate the discriminator system to exactly 5mA/MHz.

DELTA F SWEEP ATTENUATOR (BLOCK E)

The 0 to 10-volt A58 20-30 sweep generator sweep ramp (P1-1) is selected and attenuated depending upon the state of U12 pin 15 and U12 pin 2 (block D). Figure A43-4 (A43 Schematic) shows the state of each switch, U1 and U2, for all input combinations on the latched control lines.

Analog switch U1A, when closed, passes the 0 to 10 volt ramp to the summing junction in summing amplifier (block F) with no attenuation. When switch U1D is closed the sweep ramp is routed through R26 and R25 which results in one tenth of the current being summed. Refer to Figure A43-2 for the simplified SWEEP ATTENUATOR circuit diagram.

Analog switches U2A and U2B provide feed-forward paths, connecting the 0 to 10V ramp directly to the output current source. The feed-forward path helps compensate for the slow response of the discriminator loop. U2-switches C and D perform logic functions. See the table on the schematic diagram for details.

SUMMING AMPLIFIER (BLOCK F)

U3 is configured as a noninverting integrator. The voltage at the input to the integrator (junction of R43, R50 in current source (block B) and R40 in pretune (block D, etc.) is forced to 0 volts by the discriminator feedback through R50. With zero volts at the input, R40 will sink 1.5 mA. Since no current is flowing into the integrator, the following condition applies:

$$\text{Pretune current} + \text{discriminator current} + \text{sweep current} = 1.5 \text{ mA}$$

The sensitivity of this node is 5mA/MHz; e.g. if 0.005 mA of sweep current is added to the node, the input to the pulse generator (block A) will decrease by 0.001 MHz, causing the discriminator to reduce its output current by 0.005mA — exactly canceling the sweep current.

OUTPUT CURRENT SOURCE (BLOCK G)

The emitter of Q2 provides a virtual ground to sum error currents from:

- U3
- The signal from the delta F sweep attenuator (block E)
- The phase-lock inputs

The phase-lock feed-forward path reduces the lock time by feeding the discriminator tune voltage ahead to the output current source.

The output of the current source is a current of 1 to 9 mA. This output goes to the A40 PLL2 VCO.

A43 PLL2 Discriminator Circuit Description

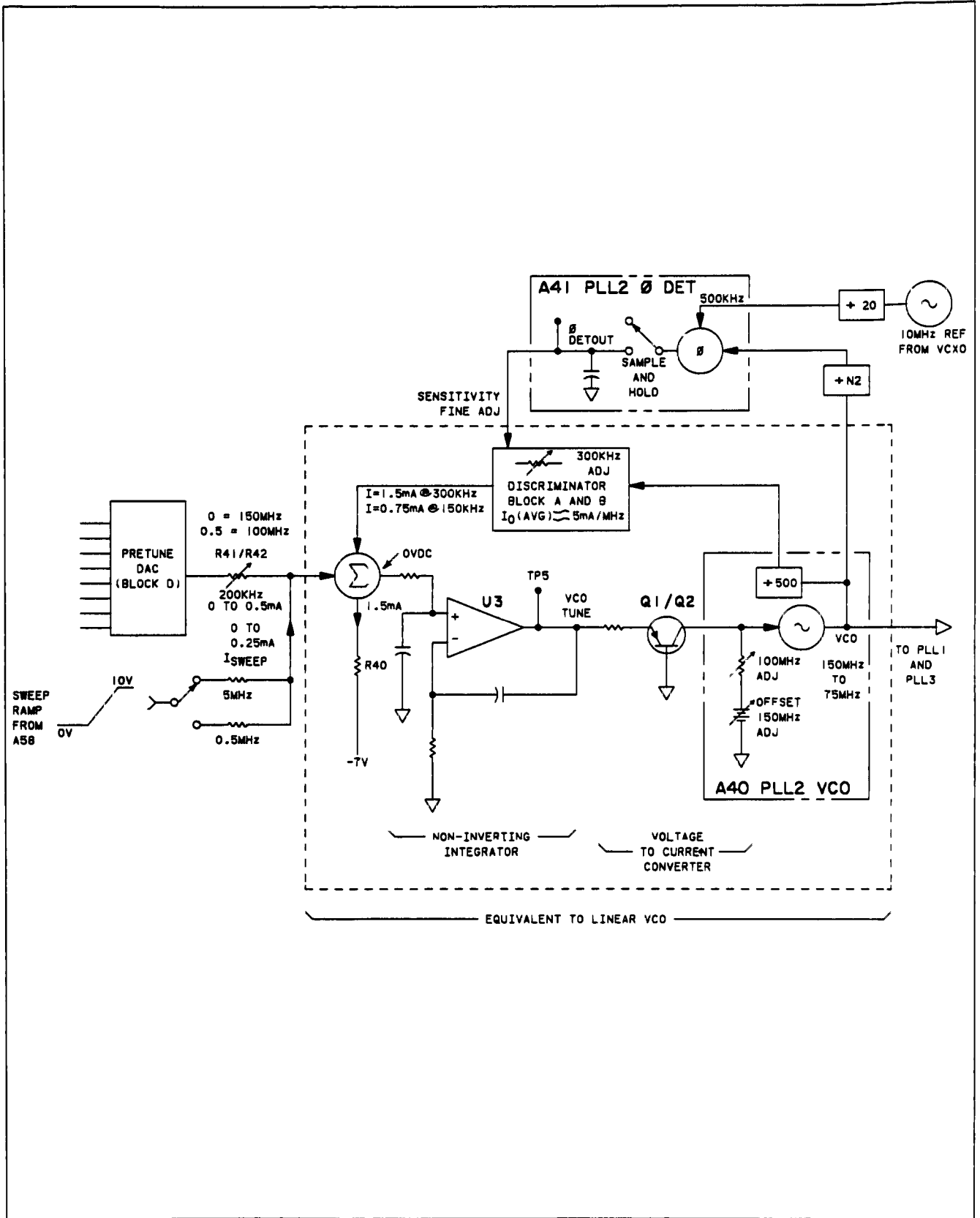

Figure A43-1. Simplified A43 PLL2 Discriminator Diagram

A43 PLL2 Discriminator Circuit Description

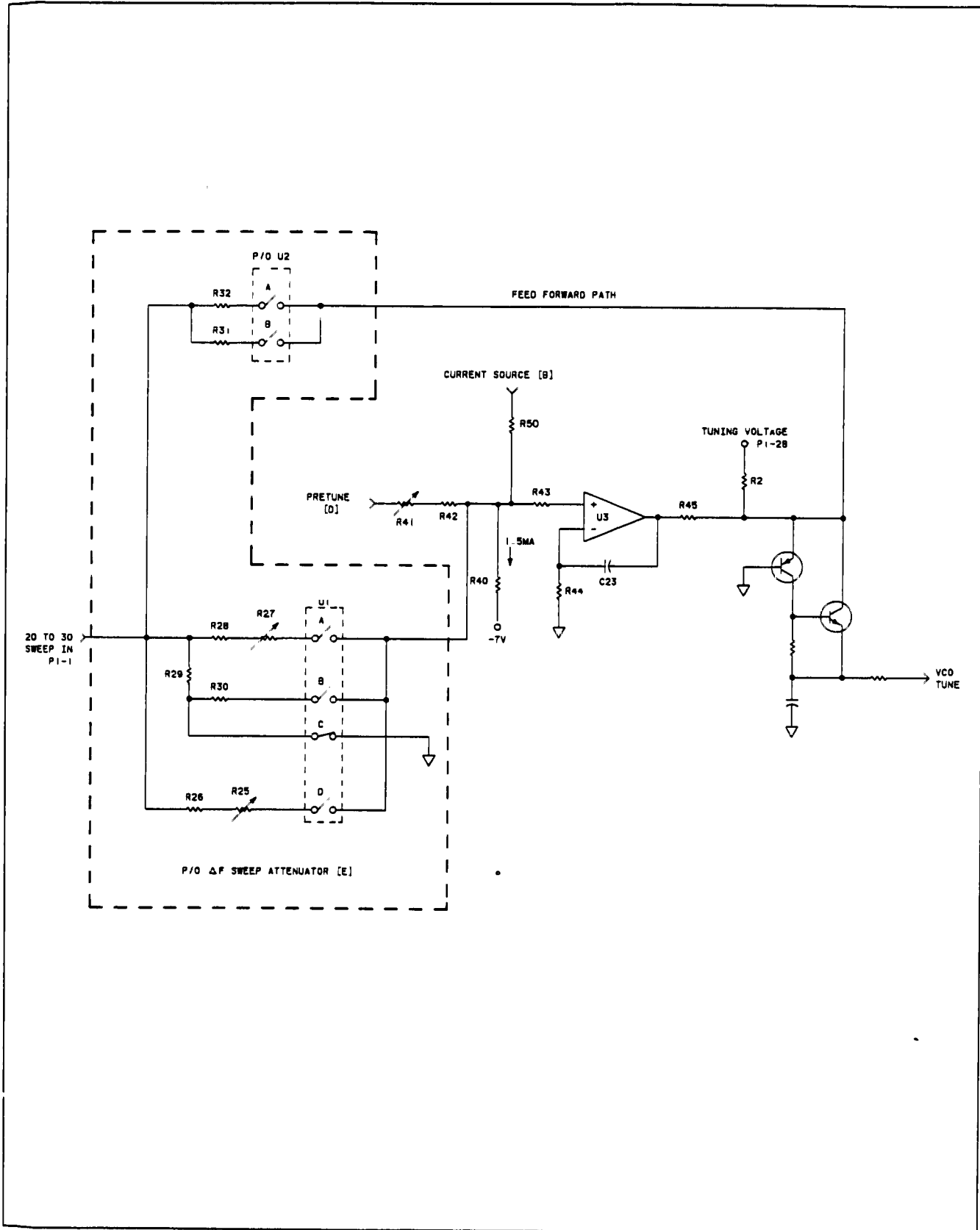

Figure A43-2. Simplified ΔF Sweep Attenuator Circuit

A43 PLL2 Discriminator Component-Level Troubleshooting

Table A43-1. A43 PLL2 Discriminator Pin I/O

Pin	Mnemonic	Levels	Source	Destination
1 19	20/30 LCK3	0 TO +10V TTL (LOW TRUE)	XA58P1-41 XA59P1-108	E D
2 20	HLE2 RGND	TTL (HIGH TRUE) 0V	XA59P1-53 A62 STAR GND	*NOT USED *H
3 21	DB1 DB0	TTL (LOW TRUE) TTL (LOW TRUE)	XA60P1-76 XA60P1-20	*D *D
4 22	DB3 DB2	TTL (LOW TRUE) TTL (LOW TRUE)	XA60 1-77 XA60P1-21	*D *D
5 23	DB5 DB4	TTL (LOW TRUE) TTL (LOW TRUE)	XA60P1-78 XA60P1-22	*D *D
6 24	DB7 DB6	TTL (LOW TRUE) TTL (LOW TRUE)	XA60P1-79 XA60P1-23	*D *D
7 25	DB9 DB8	TTL (LOW TRUE) TTL (LOW TRUE)	* *	*D *D
8 26	DB11 DB10	TTL (LOW TRUE) TTL (LOW TRUE)	* *	*D *D
9 27	-7V REF GND	-7V 0V	C A62 STAR GND	XA41P1-7 *H
10 28	N2 TUNE RTN N2 TUNE	0V 0 TO +7V	XA41P1-8 XA41P1-23	C B G
11 29	GND GND	0V 0V	A62 STAR GND A62 STAR GND	*H *H
12 30	GND	0V	A62 STAR GND	*H
13 31	GND	0V	A62 STAR GND	*H
14 32	GND	0V	A62 STAR GND	*H
15 33	-10V -10V	-10V -10V	XA53P1-12, 13, 31, 32 XA53P1-12, 13, 31, 32	*H *H
16 34	+20V +20V	+20V +20V	XA52P1-16, 40 XA52P1-16, 40	*H *H
17 35	GND GND	0V 0V	A62 STAR GND A62 STAR GND	*H *H
18 36	+5.2V +5.2V	+5.2V +5.2V	XA52P1-17, 18, 41, 42 XA52P1-17, 18, 41, 42	*H *H

A single letter in the source or destination column refers to a function block on this assembly schematic.

An asterisk (*) denotes multiple sources or destinations; refer to the A62 motherboard wiring list for a complete representation of signal sources and destinations.

A43 PLL2 Discriminator Component-Level Troubleshooting

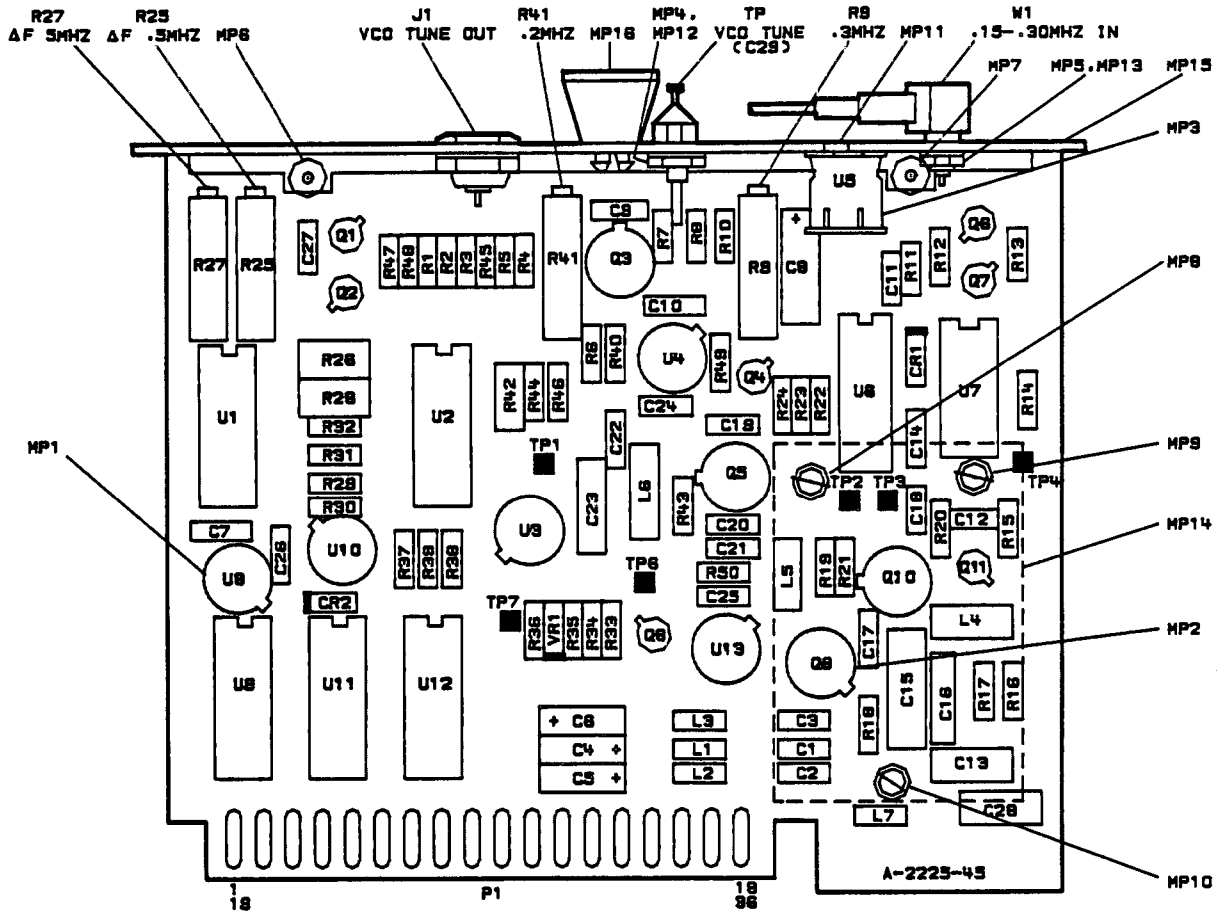

HP Part Number: 08340-60049

Figure A43-3. A43 PLL2 Discriminator Component Location Diagram

A43 PHASE LOCK LOOP 2 (PLL2) DISCRIMINATOR 0834C-60049

NOTES:
 1. RESISTANCE VALUES SHOWN ARE IN OHMS, CAPACITANCE IN MICROFARADS, AND UNLESS OTHERWISE NOTED.
 2. A434 CENTER CONDUCTOR IS ELECTRICALLY CONNECTED TO THE PC BOARD THROUGH A SOLDERED 24 GAUGE FINE WIRE. A MECHANICAL SCREW CONNECTION THROUGH THE ASSEMBLY MOUNTING HARDWARE.
 3. SHIELDED MOUNTED TO BACKSIDE OF BOARD.

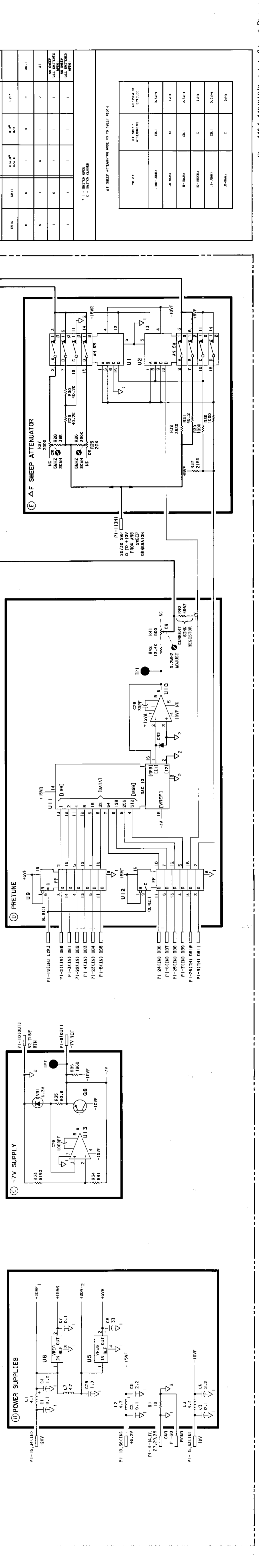
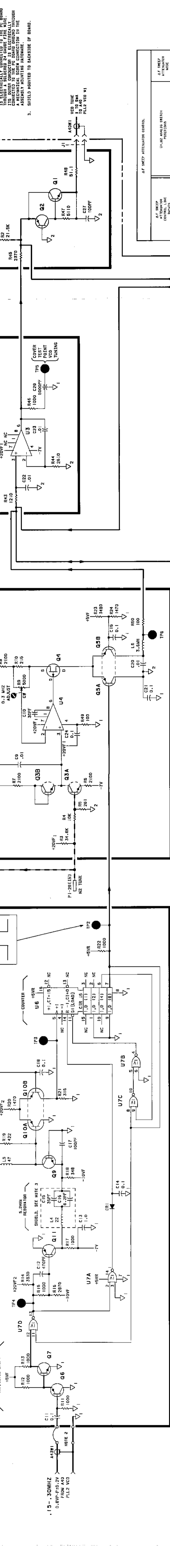

Figure A43-4. A43 PLL2 Discriminator Schematic Diagram A43-9/A43-10 20/30 Loops

A43 PLL2 Discriminator Component-Level Troubleshooting

Table A43-2. A43 PLL2 Discriminator Replaceable Parts

Reference Designation	HP Part Number	C D	Qty	Description	Mfr Code	Mfr Part Number
A43	08340-60049	0	1	PLL2 DISCRIMINATOR ASSEMBLY	28480	08340-60225
A43C1	0160-4835	7	10	CAPACITOR-FXD 1UF ± 10% 50VDC CER	28480	0160-4835
A43C2	0160-4835	7		CAPACITOR-FXD 1UF ± 10% 50VDC CER	28480	0160-4835
A43C3	0160-4835	7		CAPACITOR-FXD 1UF ± 10% 50VDC CER	28480	0160-4835
A43C4	0180-0291	3	1	CAPACITOR-FXD 1UF ± 10% 35VDC TA	56289	150D105X9035A2
A43C5	0180-0197	8	2	CAPACITOR-FXD 2.2UF ± 10% 20VDC TA	56289	150D225X9020A2
A43C6	0180-0197	8		CAPACITOR-FXD 2.2UF ± 10% 20VDC TA	56289	150D225X9020A2
A43C7	0160-4835	7		CAPACITOR-FXD 1UF ± 10% 50VDC CER	28480	0160-4835
A43C8	0180-0229	7	1	CAPACITOR-FXD 33UF ± 10% 10VDC TA	56289	150D336X9010B2
A43C9	0160-4832	4	3	CAPACITOR-FXD 01UF ± 10% 100VDC CER	28480	0160-4832
A43C10	0160-5797	2	2	CAPACITOR-FXD 30PF ± 5% 200VDC MICA	28480	0160-5797
A43C11	0160-4835	7		CAPACITOR-FXD 1UF ± 10% 50VDC CER	28480	0160-4835
A43C12	0160-4808	4	1	CAPACITOR-FXD 470PF ± 5% 100VDC CER	28480	0160-4808
A43C13	0160-0127	2	2	CAPACITOR-FXD 1UF ± 20% 25VDC CER	28480	0160-0127
A43C14	0160-4835	7		CAPACITOR-FXD 1UF ± 10% 50VDC CER	28480	0160-4835
A43C15	0160-5798	3	1	CAPACITOR-CER 36 PF ± 5% 200VDC CER	28480	0160-5798
A43C16	0160-4793	6	1	CAPACITOR-FXD 6.8PF ± 5PF 100VDC CER	28480	0160-4793
A43C17	0160-4801	7	2	CAPACITOR-FXD 100PF ± 5% 100VDC CER	28480	0160-4801
A43C18	0160-4835	7		CAPACITOR-FXD 1UF ± 10% 50VDC CER	28480	0160-4835
A43C19	0160-4835	7		CAPACITOR-FXD 1UF ± 10% 50VDC CER	28480	0160-4835
A43C20	0160-4832	4		CAPACITOR-FXD 01UF ± 10% 100VDC CER	28480	0160-4832
A43C21	0160-4835	7		CAPACITOR-FXD 1UF ± 10% 50VDC CER	28480	0160-4835
A43C22	0160-4832	4		CAPACITOR-FXD 01UF ± 10% 100VDC CER	28480	0160-4832
A43C23	0160-0161	4	1	CAPACITOR-FXD 01UF ± 10% 200VDC POLYE	28480	0160-0161
A43C24	0160-4835	7		CAPACITOR-FXD 1UF ± 10% 50VDC CER	28480	0160-4835
A43C25	0160-4822	2	1	CAPACITOR-FXD 1000PF ± 5% 100VDC CER	28480	0160-4822
A43C26	0160-5797	2		CAPACITOR-FXD 30PF ± 5% 200VDC MICA	28480	0160-5797
A43C27	0160-4801	7		CAPACITOR-FXD 100PF ± 5% 100VDC CER	28480	0160-4801
A43C28	0160-4535	4	1	CAPACITOR-FXD 1UF ± 10% 50VDC CER	28480	0160-4535
A43C29	0160-2437	1	1	CAPACITOR-FDTHRU 5000PF +80 -20% 200V	28480	0160-2437
A43CR1	1901-0539	3	2	DIODE-SM SIG SCHOTTKY	28480	1901-0539
A43CR2	1901-0539	3		DIODE-SM SIG SCHOTTKY	28480	1901-0539
A43J1	1250-0544	9	1	CONNECTOR-RF MALE SMB	28480	1250-0544
A43L1	9140-0144	0	4	INDUCTOR RF-CH-MLD 4.7UH 10% 105DX 26LG	28480	9140-0144
A43L2	9140-0144	0		INDUCTOR RF-CH-MLD 4.7UH 10% 105DX 26LG	28480	9140-0144
A43L3	9140-0144	0		INDUCTOR RF-CH-MLD 4.7UH 10% 105DX 26LG	28480	9140-0144
A43L4	9140-0392	0	1	INDUCTOR RF-CH-MLD 22UH 3% 166DX 385LG	28480	9140-0392
A43L5	9100-1629	4	1	INDUCTOR RF-CH-MLD 47UH 5% 166DX 385LG	28480	9100-1629
A43L6	9100-1666	9	1	INDUCTOR RF-CH-MLD 3.6MH 5% 23DX 57LG	28480	9100-1666
A43L7	9140-0144	0		INDUCTOR RF-CH-MLD 4.7UH 10% 105DX 26LG	28480	9140-0144
A43MP1				NOT ASSIGNED		
A43MP2				NOT ASSIGNED		
A43MP3	1205-0250	9	1	THERMAL LINK SGL TO-5/TO-39-CS	28480	1205-0250
A43MP4	2190-0009	4	1	WASHER-LK INTL T NO. 8 168-IN-ID	28480	2190-0009
A43MP5	2190-0124	4	1	WASHER-LK INTL T NO. 10 195-IN-ID	28480	2190-0124
A43MP6	2200-0101	0	5	SCREW-MACH 4-40 188-IN-LG PAN-HD-POZI	00000	ORDER BY DESCRIPTION
A43MP7	2200-0101	0		SCREW-MACH 4-40 188-IN-LG PAN-HD-POZI	00000	ORDER BY DESCRIPTION
A43MP8	2200-0101	0		SCREW-MACH 4-40 188-IN-LG PAN-HD-POZI	00000	ORDER BY DESCRIPTION
A43MP9	2200-0101	0		SCREW-MACH 4-40 188-IN-LG PAN-HD-POZI	00000	ORDER BY DESCRIPTION
A43MP10	2200-0101	0		SCREW-MACH 4-40 188-IN-LG PAN-HD-POZI	00000	ORDER BY DESCRIPTION
A43MP11	2200-0164	5	1	SCREW-MACH 4-40 188-IN-LG UNCT 82 DEG	00000	ORDER BY DESCRIPTION
A43MP12	2580-0002	4	1	NUT-HEX-DBL-CHAM 8-32-THD 085-IN-THK	00000	ORDER BY DESCRIPTION
A43MP13	2950-0078	9	1	NUT-HEX-DBL-CHAM 10-32-THD 067-IN-THK	28480	2950-0078
A43MP14	08340-00037	6	1	SHIELD-PLL2 DISCRIMINATOR	28480	08340-00037
A43MP15	08340-20089	0	1	COVER-PC 2 DISCRIMINATOR	28480	08340-20089
A43MP16	86701-40001	9	1	EXTRACTOR-PC BOARD	28480	86701-40001
A43Q1	1854-0404	0	1	TRANSISTOR NPN SI TO-18 PD=360MW	28480	1854-0404
A43Q2	1853-0281	9	2	TRANSISTOR PNP 2N2907A SI TO-18 PD=400MW	04713	2N2907A
A43Q3	1854-0475	5	1	TRANSISTOR-DUAL NPN PD=750MW	28480	1854-0475
A43Q4	1855-0413	3	1	TRANSISTOR J-FET P-CHAN D-MODE TO-18 SI	27014	2N5116
A43Q5	1853-0269	3	1	TRANSISTOR-DUAL PNP 2N3809 PD=600MW	01295	2N3809
A43Q6	1853-0007	7	1	TRANSISTOR PNP 2N3251 SI TO-18 PD=360MW	04713	2N3251
A43Q7	1854-0019	3	1	TRANSISTOR NPN SI TO-18 PD=360MW	28480	1854-0019
A43Q8	1853-0281	9		TRANSISTOR PNP 2N2907A SI TO-18 PD=400MW	04713	2N2907A
A43Q9	1854-0247	9	1	TRANSISTOR NPN SI TO-39 PD=1W FT=800MHZ	28480	1854-0247
A43Q10	1853-0388	7	1	TRANSISTOR-DUAL PNP PD=600MW	28480	1853-0388

A43 PLL2 Discriminator Component-Level Troubleshooting

Table A43-2. A43 PLL2 Discriminator Replaceable Parts

Reference Designation	HP Part Number	C	D	Qty	Description	Mfr Code	Mfr Part Number
A43Q11	1853-0034	0		1	TRANSISTOR PNP SI TO-18 PD=380MW	28480	1853-0034
A43R1	0757-0348	2		1	RESISTOR 10 1% .125W F TC=0±100	24546	C4-1/8-T0-10R0-F
A43R2	0757-0199	3		1	RESISTOR 21.5K 1% .125W F TC=0±100	24546	C4-1/8-T0-2152-F
A43R3	0757-0123	3		1	RESISTOR 34.8K 1% .125W F TC=0±100	28480	0757-0123
A43R4	0757-0442	9		1	RESISTOR 10K 1% .125W F TC=0±100	24546	C4-1/8-T0-1002-F
A43R5	0698-3132	4		1	RESISTOR 281 1% .125W F TC=0±100	24546	C4-1/8-T0-2810-F
A43R6	0699-0078	3		3	RESISTOR-FXD 2.1K OHM .1% .1W	28480	0699-0078
A43R7	0699-0078	3		3	RESISTOR-FXD 2.1K OHM .1% .1W	28480	0699-0078
A43R8	0699-0078	3		3	RESISTOR-FXD 2.1K OHM .1% .1W	28480	0699-0078
A43R9	2100-1739	0		1	RESISTOR-TRMR 5K 10% WW SIDE-ADJ 20-TRN	02660	3810P-502
A43R10	0699-0082	9		1	RESISTOR-FXD 215 OHM 1% .1W	28480	0699-0082
A43R11	0757-0280	3		9	RESISTOR 1K 1% .125W F TC=0±100	24546	C4-1/8-T0-1001-F
A43R12	0757-0280	3		3	RESISTOR 1K 1% .125W F TC=0±100	24546	C4-1/8-T0-1001-F
A43R13	0757-0280	3		3	RESISTOR 1K 1% .125W F TC=0±100	24546	C4-1/8-T0-1001-F
A43R14	0698-3153	9		2	RESISTOR 3.83K 1% .125W F TC=0±100	24546	C4-1/8-T0-3831-F
A43R15	0757-0280	3		3	RESISTOR 1K 1% .125W F TC=0±100	24546	C4-1/8-T0-1001-F
A43R16	0698-3151	7		1	RESISTOR 2.87K 1% .125W F TC=0±100	24546	C4-1/8-T0-2871-F
A43R17	0757-0280	3		3	RESISTOR 1K 1% .125W F TC=0±100	24546	C4-1/8-T0-1001-F
A43R18	0698-3445	2		1	RESISTOR 348 1% .125W F TC=0±100	24546	C4-1/8-T0-348R-F
A43R19	0698-3447	4		1	RESISTOR 422 1% .125W F TC=0±100	24546	C4-1/8-T0-422R-F
A43R20	0757-1094	9		2	RESISTOR 1.47K 1% .125W F TC=0±100	24546	C4-1/8-T0-1471-F
A43R21	0698-3444	1		1	RESISTOR 318 1% .125W F TC=0±100	24546	C4-1/8-T0-316R-F
A43R22	0757-0280	3		3	RESISTOR 1K 1% .125W F TC=0±100	24546	C4-1/8-T0-1001-F
A43R23	0698-3152	8		1	RESISTOR 3.48K 1% .125W F TC=0±100	24546	C4-1/8-T0-348R-F
A43R24	0757-1094	9		9	RESISTOR 1.47K 1% .125W F TC=0±100	24546	C4-1/8-T0-1471-F
A43R25	2100-1972	3		1	RESISTOR-TRMR 20K 10% WW SIDE-ADJ 20-TRN	02660	3810P-203
A43R26	0699-0081	8		1	RESISTOR-FXD 390 1K OHM .1% .12W	28480	0699-0081
A43R27	2100-2851	9		1	RESISTOR-TRMR 2K 10% WW SIDE-ADJ 20-TRN	02660	3810P-202
A43R28	0699-0080	7		1	RESISTOR-FXD 39K OHM .1% .12W	28480	0699-0080
A43R29	0698-3499	6		3	RESISTOR 40.2K 1% .125W F TC=0±100	24546	C4-1/8-T0-4022-F
A43R30	0698-3499	6		3	RESISTOR 40.2K 1% .125W F TC=0±100	24546	C4-1/8-T0-4022-F
A43R31	0698-3499	6		3	RESISTOR 40.2K 1% .125W F TC=0±100	24546	C4-1/8-T0-4022-F
A43R32	0698-3153	9		9	RESISTOR 3.83K 1% .125W F TC=0±100	24546	C4-1/8-T0-3831-F
A43R33	0699-0084	1		1	RESISTOR-FXD 6.19K OHM .1% .1W	28480	0699-0084
A43R34	0699-0083	0		1	RESISTOR-FXD 681 OHM 1% .1W	28480	0699-0083
A43R35	0757-0400	9		1	RESISTOR 90.9 1% .125W F TC=0±100	24546	C4-1/8-T0-90R9-F
A43R36	0698-0083	8		1	RESISTOR 1.98K 1% .125W F TC=0±100	24546	C4-1/8-T0-1981-F
A43R37	0698-0084	9		1	RESISTOR 2.15K 1% .125W F TC=0±100	24546	C4-1/8-T0-2151-F
A43R38	0757-0280	3		3	RESISTOR 1K 1% .125W F TC=0±100	24546	C4-1/8-T0-1001-F
A43R39	0757-0280	3		3	RESISTOR 1K 1% .125W F TC=0±100	24546	C4-1/8-T0-1001-F
A43R40	0699-0079	4		1	RESISTOR-FXD 4.667K OHM .1% .1W	28480	0699-0079
A43R41	2100-1799	2		1	RESISTOR-TRMR 500 10% WW SIDE-ADJ 20-TRN	02660	3810P-501
A43R42	0698-8831	0		1	RESISTOR 13.4K 1% .125W F TC=0±100	28480	0698-8831
A43R43	0757-0274	5		1	RESISTOR 1.21K 1% .125W F TC=0±100	24546	C4-1/8-T0-1211-F
A43R44	0698-0085	0		1	RESISTOR 2.61K 1% .125W F TC=0±100	24546	C4-1/8-T0-2611-F
A43R45	0698-3150	6		1	RESISTOR 2.37K 1% .125W F TC=0±100	24546	C4-1/8-T0-2371-F
A43R46	0757-0280	3		3	RESISTOR 1K 1% .125W F TC=0±100	24546	C4-1/8-T0-1001-F
A43R47	0757-0438	3		1	RESISTOR 5.11K 1% .125W F TC=0±100	24546	C4-1/8-T0-5111-F
A43R48	0757-0394	0		1	RESISTOR 51.1 1% .125W F TC=0±100	24546	C4-1/8-T0-51R1-F
A43R49	0757-0401	0		2	RESISTOR 100 1% .125W F TC=0±100	24546	C4-1/8-T0-101-F
A43R50	0757-0401	0		2	RESISTOR 100 1% .125W F TC=0±100	24546	C4-1/8-T0-101-F
A43TP1	0360-0535	0		6	TERMINAL TEST POINT PCB	00000	ORDER BY DESCRIPTION
A43TP2	0360-0535	0		6	TERMINAL TEST POINT PCB	00000	ORDER BY DESCRIPTION
A43TP3	0360-0535	0		6	TERMINAL TEST POINT PCB	00000	ORDER BY DESCRIPTION
A43TP4	0360-0535	0		6	TERMINAL TEST POINT PCB	00000	ORDER BY DESCRIPTION
A43TP5	0360-0535	0		6	TERMINAL TEST POINT PCB See A43C29	00000	ORDER BY DESCRIPTION
A43TP6	0360-0535	0		6	TERMINAL TEST POINT PCB	00000	ORDER BY DESCRIPTION
A43TP7	0360-0535	0		6	TERMINAL TEST POINT PCB	00000	ORDER BY DESCRIPTION
A43U1	1826-0811	4		2	ANALOG SWITCH 4 SPST 16 CERDIP	02180	SW-01FQ
A43U2	1826-0811	4		2	ANALOG SWITCH 4 SPST 16 CERDIP	02180	SW-01FQ
A43U3	1826-0471	2		1	IC OP AMP LOW-DRIFT TO-99 PKG	28480	1826-0471
A43U4	1820-0223	0		2	IC OP AMP GP TO-99 PKG	3L585	CA301AT
A43U5	1820-0429	8		1	IC v RGLTR TO-39	18324	LM309H
A43U6	1820-1194	6		1	IC CNTR TTL LS BIN UP/DOWN SYNCHRO	01295	SN74LS193N
A43U7	1820-1144	6		1	IC GATE TTL LS NOR QUAD 2-INP	01295	SN74LS02N
A43U8	1826-0353	9		1	IC 786L15 v RGLTR TO-39	07263	UA78L15ACH
A43U9	1820-1196	8		2	IC FF TTL LS D-TYPE POS-EDGE-TRIG COM	01295	SN74LS174N
A43U10	1826-0059	2		1	IC OP AMP GP TO-99 PKG	01295	LM201AL

A43 PLL2 Discriminator Component-Level Troubleshooting

Table A43-2. A43 PLL2 Discriminator Replaceable Parts

Reference Designation	HP Part Number	C D	Qty	Description	Mfr Code	Mfr Part Number
A43U11	1828-0448	3	1	IC CONV 10-B-D/A 18-DIP-P PKG	24355	AD7520LN(SEL)
A43U12	1820-1196	8		IC FF TTL LS D-TYPE POS-EDGE-TRIG COM	01295	SN74LS174N
A43U13	1820-0223	0		IC OP AMP GP TO-99 PKG	3L585	CA301AT
A43VR1	1902-0692	1	1	DIODE-ZNR 6.3V 1% DO-7 PD= .4W TC= + .001%	28480	1902-0692
A43W1	08340-60112	4	1	CABLE ASSEMBLY-A43	28480	08340-60112

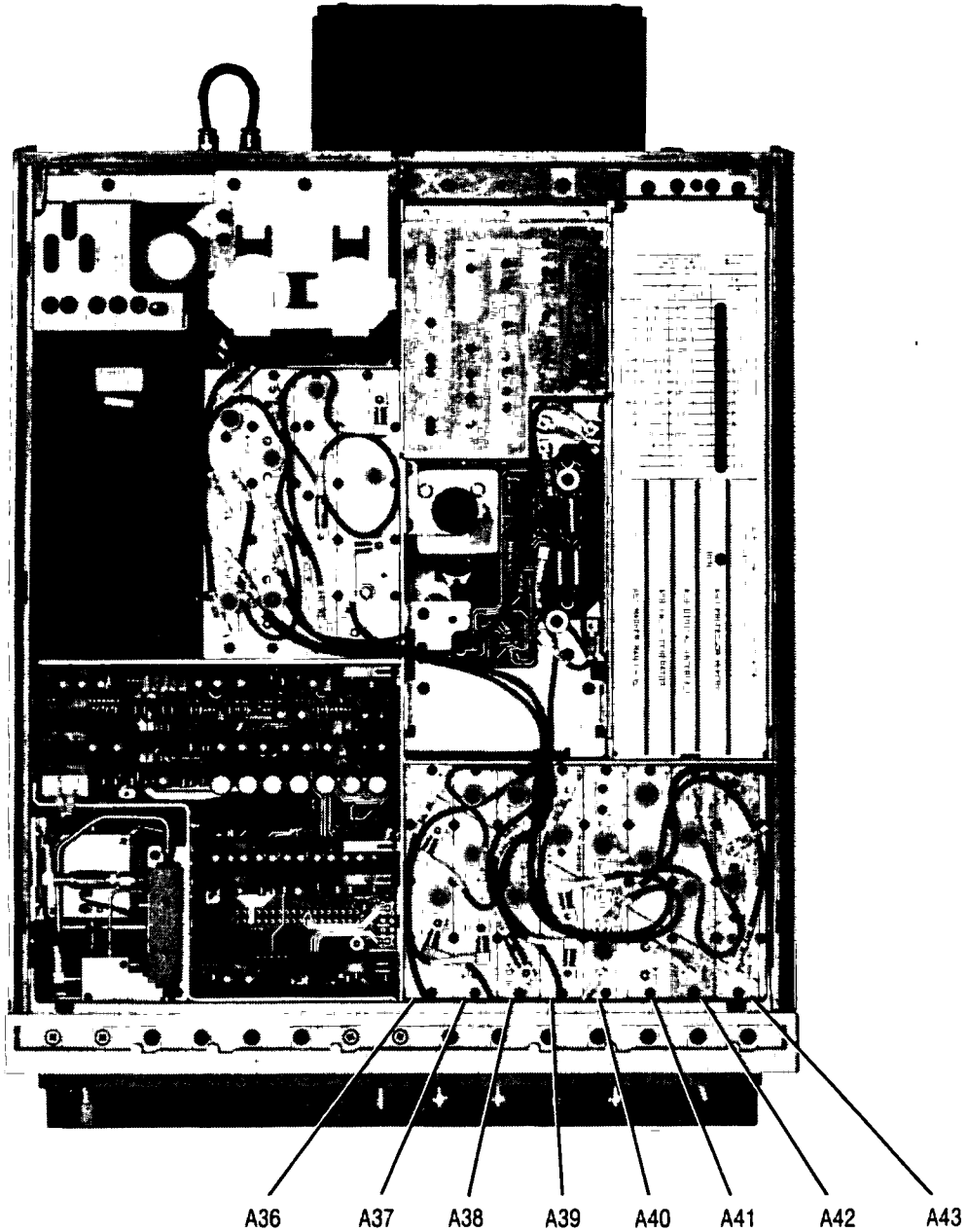

Bottom View (Bottom Cover Removed)

Figure A43-5. 20-30 Loop Major Assemblies Diagram

Sweep Generator/YO Loop Component-Level Service D

CONTENTS

A23 FM DRIVER

CIRCUIT DESCRIPTION	A23-1
Assembly Purpose	A23-1
Range Attenuator (Block A)	A23-1
External Harmonic Number Attenuator (Block B)	A23-1
Internal Harmonic Number Attenuator (Block C)	A23-1
FM Coil Driver (Block D)	A23-2
Attenuator Switch Driver (Block E)	A23-2
Overmodulation Detector (Block F)	A23-2
Power Supply Filtering (Block G)	A23-2
TRUBLESHOOTING	A23-3
Equipment Required	A23-3
Troubleshooting FM Operation	A23-3
Troubleshooting Overmodulation Detection Circuitry	A23-5
A23 Driver Pin I/O	A23-6
A23 FM Driver Component Location Diagram	A23-8
A23 FM Driver Schematic	A23-9
A23 FM Driver Replaceable Parts	A23-11

A47 SENSE RESISTOR ASSEMBLY

CIRCUIT DESCRIPTION	A47-1
Assembly Purpose	A47-1
A47W2P1 to A62J32 Pin I/O	A47-2
A47W1P1 to A62J29 Pin I/O	A47-2
A47 Sense Resistor Assembly Component Location Diagram	A47-3
A47 Sense Resistor Assembly Replaceable Parts	A47-5

A48 YO LOOP SAMPLER

CIRCUIT DESCRIPTION	A48-1
Assembly Purpose	A48-1
Sampler Drive Amplifier (Block A)	A48-1
A48U1 Sampler (Block B)	A48-1
IF Preamplifier (Block C)	A48-1
Buffer Amplifier (Block D), 70 MHz Low-Pass Filter (LPF) (Block E)	A48-1
Gain Adjust (Block F)	A48-2
Output Amplifier (Block G)	A48-2
A48 YO Loop Sampler Component Location Diagram	A48-4
A48 YO Loop Sampler Schematic Diagram	A48-5
A48 YO Loop Sampler Replaceable Parts	A48-7

CONTENTS (Cont'd)

A49 YO LOOP PHASE DETECTOR

CIRCUIT DESCRIPTION	A49-1
Assembly Purpose	A49-1
70 MHz Low-Pass Filter (Block A)	A49-1
IF Limiter (Block B), 20-30 Limiter (Block C)	A49-2
Phase/Frequency Detector (Block D)	A49-2
FM Overmodulation Detector (Block E)	A49-2
Loop Integrators (Block F)	A49-3
Test Jumper (Block G)	A49-3
An Overview of the Sample and Hold and FM Coil Driver	A49-4
Sample and Hold (Block H)	A49-4
FM Coil Driver (Block I)	A49-5
Unlocked Detectors (Block J)	A49-5
Power Supplies (Block K)	A49-6
Logic Inverter/Translator (Block L)	A49-6
TROUBLESHOOTING	A49-7
YO Unlock	A49-7
Limiters (Block B and Block C)	A49-7
Phase/Frequency Detector (Block D)	A49-7
Sample and Hold (Block H)	A49-8
FM Coil Driver (Block I)	A49-8
Logic Inverter/Translator (Block L)	A49-8
A49 YO Loop Phase Detector Component Location Diagram	A49-9
A49 YO Loop Phase Detector Replaceable Parts	A49-11

A50 YO LOOP INTERCONNECT

CIRCUIT DESCRIPTION	A50-1
Assembly Purpose	A50-1
A62J2 to A50W1P1 Pin I/O	A50-2
A50 YO Loop Interconnect Component Location Diagram	A50-4
A49 YO Loop Phase Detector and A50 YO Loop Interconnect Schematic Diagram	A50-5
A50 YO Loop Interconnect Replaceable Parts	A50-7

A54 YO PRETUNE/DELAY COMPENSATION

CIRCUIT DESCRIPTION	A54-1
Assembly Purpose	A54-1
Pretune Register (Block A)	A54-1
Pretune DAC (Block B)	A54-1
Summing Amplifier (Block C)	A54-2
Voltage Reference (Block D)	A54-2
Sweep Disable Switch (Block E)	A54-2
YO Delay Compensation (Block F)	A54-3
YO Retrace Kick Pulse Generator (Block G)	A54-3
Power Supplies (Block H)	A54-4

CONTENTS (Cont'd)

TROUBLESHOOTING	A54-5
Pretune Incorrect	A54-5
LKICK Incorrect	A54-5
VCOMP Check	A54-6
VCOMP Incorrect	A54-6
A54 YO Pretune/Delay Compensation P1 Pin I/O	A54-7
A54 YO Pretune DAC/Delay Compensation Component Location Diagram	A54-8
A54 YO Pretune/Delay Compensation Schematic Diagram	A54-9
A54 Pretune/Delay Compensation Replaceable Parts	A54-11

A55 YO DRIVER ASSEMBLY

CIRCUIT DESCRIPTION	A55-1
Assembly Purpose	A55-1
Discrete Operational-Amplifier (Block A)	A55-1
Voltage-to-Current Converter (Block B)	A55-1
VCOMP Switch Logic (Block C)	A55-2
Filter Switch (Block D)	A55-2
YO Error/Offset Summing Amplifier (Block E)	A55-2
Main Summing Amplifier (Block F)	A55-2
Power Supplies (Block G)	A55-2
Kick Pulse Driver (Block H)	A55-3
A55 YO Driver P1 Pin I/O	A55-5
A55 YO Driver Component Location Diagram	A55-6
A55 YO Driver Schematic Diagram	A55-7
A55 YO Driver Replaceable Parts	A55-9

A58 SWEEP GENERATOR

CIRCUIT DESCRIPTION	A58-1
Assembly Purpose	A58-1
Sweep Time Register (Block A)	A58-1
Reset Register (Block B)	A58-1
Reset DAC (Block C)	A58-1
Voltage Reference (Block D)	A58-1
Sweep Width Register (Block E)	A58-2
Sweep Width Range Switch Driver (Block F)	A58-2
Sweep Time DAC (Block G)	A58-3
Sweep Time Switch Drivers (Block H)	A58-3
Sweep Scaling Resistors (Block I)	A58-3
Virtual Ground Amplifier (Block J)	A58-3
Ramp Generator (Block K)	A58-4
Summing Amplifier (Block L)	A58-7
Sweep Width DAC (Block M)	A58-8
Sweep Width Range Attenuator (Block N)	A58-9
Sweep Buffer (Block O)	A58-9
Sweep Control Logic (Block P)	A58-10
Current Shunt (Block Q)	A58-11
Reset Amplifier 1 (Block R)	A58-11
Reset Control Logic (Block S)	A58-11
Reset Amplifier 2 (Block T)	A58-12
Oversweep Detector (Block U)	A58-12
Power Supply Filtering (Block V)	A58-12

CONTENTS (Cont'd)

TROUBLESHOOTING	A58-13
No Sweep	A58-13
Incorrect Sweep	A58-14
A58 Sweep Generator P1 Pin I/O	A58-16
A58 Sweep Generator Component Location Diagram	A58-20
A58 Sweep Generator Schematic Diagram	A58-21
A58 Sweep Generator Replaceable Parts	A58-25

A23 FM Driver Circuit Description

ASSEMBLY PURPOSE

The FM driver assembly provides:

- FM input range attenuation
- Harmonic number attenuation
- FM coil drive
- Over modulation detection

RANGE ATTENUATOR (BLOCK A)

The range attenuator consists of:

- A high-pass filter
- A diode clamp
- Three FET switches that select one of two input sensitivities (1 or 10 MHz/V), and turn FM on/off.

When you select 10 MHz/V sensitivity, Q18 is on, Q17 is off, and the range attenuator output is not attenuated. When you select 1 MHz/V, Q17 is on, Q18 is off, and the range attenuator output is attenuated by the voltage divider.

Q16 turns the FM drive on and off when its gate goes from approximately -20 to $+0.5$ volts.

EXTERNAL HARMONIC NUMBER ATTENUATOR (BLOCK B)

This circuit provides attenuation to the FM input when an external multiplier is connected to the synthesizer output (this circuit is not used at this time).

INTERNAL HARMONIC NUMBER ATTENUATOR (BLOCK C)

This circuit provides input attenuation when the instrument is in a multiplied frequency band.

The FET switches are used to select the required attenuation. When the gate voltage on any FET is 0.5V, that FET is on, forming a voltage divider across the source and drain resistors. When more than one FET is on, the voltage divider is the parallel combination of the drain resistors and the common source resistor. Q5 and 6 are output buffers.

FM GAIN provides fine adjustments to the input to the FM coil driver (block D).

FM COIL DRIVER (BLOCK D)

This circuit is a discrete operational amplifier with a 50Ω output that drives the A44 YIG oscillator FM coil. The base of Q1 and the base of Q2 are the input for the operational amplifier. Q15 and Q20 are current sources for the push-pull output stages of Q7, and Q8 (for Q15), and Q19 and Q21 (for Q20).

The circuit gain (21 dB) is provided by R31 and the parallel combination of R36 and R37. The output impedance is 50Ω .

ATTENUATOR SWITCH DRIVER (BLOCK E)

This block consists of an input register and eight voltage comparators. The input register latches a strobe from the data bus to a voltage comparator. Each comparator drives a FET switch. The comparator negative terminals are each connected to +1.5V. When the input to the comparator positive terminal is high (TTL), the output is approximately $-20V$; when the input is low (approximately 0V), the output to the range attenuator FET gate is approximately +0.5V and the output to the harmonic number attenuator FET gate is +14V.

OVERMODULATION DETECTOR (BLOCK F)

This circuit is comprised of two comparators. If the input exceeds levels shown in the troubleshooting description below, the LOMD (low overmodulation detected) signal goes low. This signal informs the microprocessor of the overmodulation condition.

POWER SUPPLY FILTERING (BLOCK G)

This circuitry filters the power supplies used by this assembly. The $-20V$ supply uses a three-terminal regulator.

A23 FM Driver Component-Level Troubleshooting

EQUIPMENT REQUIRED

- HP 1740A oscilloscope
- HP 3325A function generator
- HP 3456A digital multimeter

TROUBLESHOOTING FM OPERATION

1. Connect the output of the function generator to the FM input of the synthesizer.
2. On the synthesizer, press [INSTR PRESET] [CW] [FM] [▲]. This initiates FM operation, at an FM sensitivity of 10 GHz/V.
3. Set the function generator to 100 kHz at 0 dBm.
4. Check the voltages at the test points shown in Table A23-1. Use a digital voltmeter to measure the DC voltage. Use an oscilloscope to measure the AC P-P voltage.

Table A23-1. Proper A23 Test Point Voltages (approximate)

Test Point	DC Voltage	AC P-P Voltage
2	-0.8	0.6
3	-1.0	0.45
6	+6.0	4.5
4	+5.0	5.0
5	+5.5	5.0

5. If a voltage listed in Table A23-1 is incorrect, troubleshoot the associated circuitry on the A23 FM driver. Tables A23-2, A23-3, and A23-4 show proper voltages for A23 FM driver circuitry.

A23 FM Driver Component-Level Troubleshooting

Table A23-2. Range Attenuator Voltages

	U3	U4	U6	Q16 Gate	Q17 Gate	Q18 Gate
FM On Off	Pin 2=0V	Pin 2=+5V	Pin 2=-20V Pin 2=+0.5V	-20V +0.5V		
1 MHz/V	Pin 5=0V Pin 19=+5V	Pin 14=-20V	Pin 1=+0.5V	-20V -20V	+0.5V	-20V
10 MHz/V	Pin 5=+5V Pin 19=0V	Pin 14=+0.5V	Pin 1=-20V	-20V -20V	-20V	+0.5V

Table A23-3. External Harmonic Number Attenuator Voltages

Multiplier	U3	M3	M2	M1	Q14 Gate	Q13 Gate	Q12 Gate
1	Pin 12 = 0V Pin 9 = 0V Pin 15 = 0V	-20V	-20V	-20V	-20V*	-20V*	-20V*

* -20V if measured with a DVM that has infinite input impedance. The actual value can vary due to the meter input impedance and gate resistor characteristics.

Table A23-4. Internal Harmonic Number Attenuator Voltages

Band	U3	B2	B1	Q3 Gate	Q4 Gate
0 (0.01-2.3 GHz)	Pin 6 = 0V Pin 16 = 0V	-20V	-20V	-20V*	-20V*
1 (2.3-7 GHz)	Pin 6 = 0V Pin 16 = 0V	-20V	-20V	-20V*	-20V*
2 (7-13.5 GHz)	Pin 6 = 0V Pin 16 = +5V	-20V	+14V	-20V*	+0.5V
3 (13.5-20 GHz)	Pin 6 = +5V Pin 16 = 0V	+14V	-20V	+0.5V	-20V*
4 (20-26.5 GHz)	Pin 6 = +5V Pin 16 = +5V	+14V	+14V	+0.5V	+0.5V

* -20V if measured with a DVM that has infinite input impedance. The actual value can vary due to the meter input impedance and gate resistor characteristics

TROUBLESHOOTING OVERMODULATION DETECTION CIRCUITRY

1. Set the function generator output to 2 MHz at 2V P-P.
2. Set the synthesizer to a CW frequency of 1 GHz, with an FM sensitivity of 10 MHz/V. This setup provides the instrument with frequency modulation within acceptable limits (Mod index = 5). A properly operating instrument does not assert LOMD low with this amount of modulation.
3. Measure A23TP2 with an oscilloscope (Channel A DC coupled). Verify the waveform shown in Figure A23-1. Verify that LOMD is high. If the signal is correct and LOMD is low, troubleshoot block F.



Figure A23-1. A23TP2 Waveform During Normal Modulation

4. Set the function generator output signal level to 3.2V P-P. This modulation level is not within design limits, and LOMD should go low, indicating overmodulation. Verify the waveform shown in Figure A23-2. If the signal is correct, and LOMD has not gone low, troubleshoot block F.

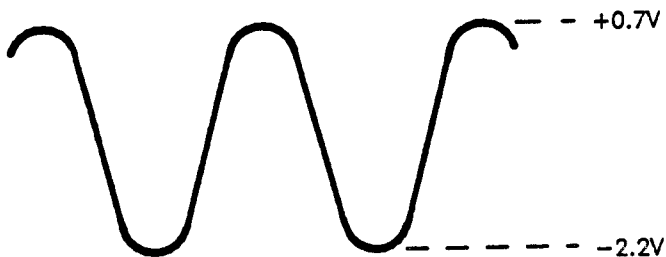

Figure A23-2. A23TP2 Waveform During Overmodulation

A23 FM Driver Component-Level Troubleshooting

Table A23-5. A23 FM Driver Pin I/O

Pin	Mnemonic	Levels	Source	Destination
1 19	+20V +20V	+20V +20V	XA52P1-16, 40 XA52P1-16, 40	*G *G
2 20				
3 21	+5.2V +5.2V	+5.2V +5.2V	XA52P1-17, 18, 41, 42 XA52P1-17, 18, 41, 42	*G *G
4 22	LOMD	TTL (LOW TRUE)	*F	XA27P1-48
5 23	-10V -10V	-10V -10V	XA53P1-12, 13, 31, 32 XA53P1-12, 13, 31, 32	*G *G
6 24	GND GND	0V 0V	A62 STAR GND A62 STAR GND	*G *G
7 25	-40V	-40V	XA53P1-11, 30	*G
8 26				
9 27	DB0 DB1	TTL TTL	XA60P1-20 XA60P1-76	E E
10 28	DB2 DB3	TTL TTL	XA60P1-21 XA60P1-77	E E
11 29	DB4 DB5	TTL TTL	XA60P1-22 XA60P1-78	E E
12 30	DB6 DB7	TTL TTL	XA60P1-23 XA60P1-79	E E
13 31				
14 32				
15 33	W11R2	TTL (LOW TRUE)	XA27P1-15	E
16 34	FMDRVR OUT FMDRVR SHIELD	ANALOG 0V	D GND2 G	A44A1J3
17 35	FM SHIELD	0V	GND1 G	J22 SHIELD
18 36	FM INPUT	-8V TO +8V	J22	A

A single letter in the source or destination column refers to a function block on this assembly schematic.

An asterisk (*) denotes multiple sources or destinations; refer to the A62 motherboard wiring list for a complete representation of signal sources and destinations.

A23 FM Driver Component-Level Troubleshooting

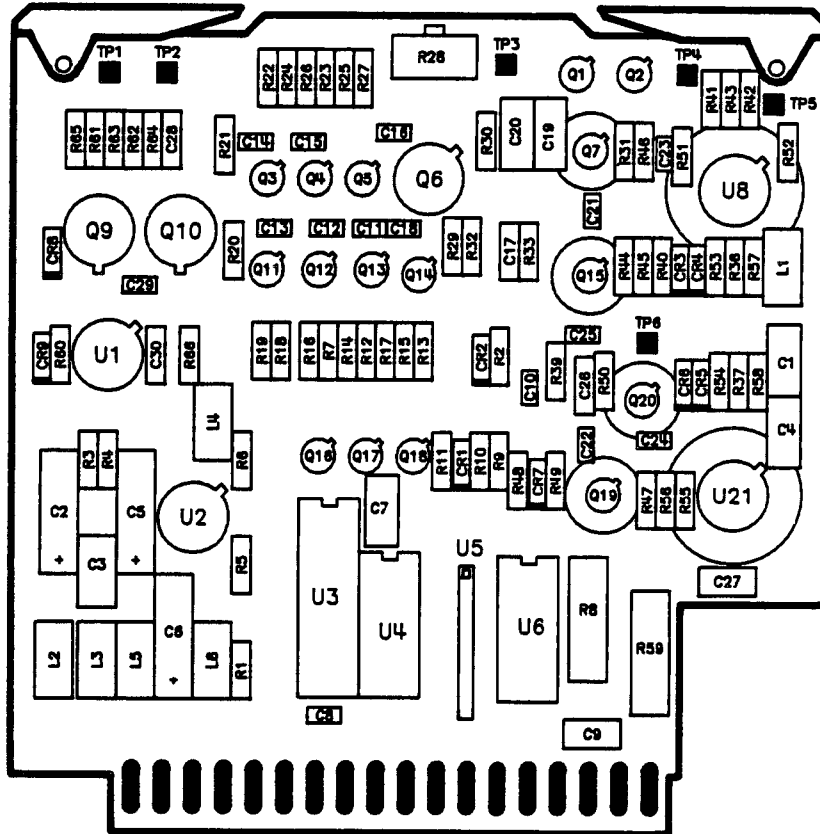

HP Part Number: 08340-60222

Figure A23-3. A23 FM Driver Component Location Diagram

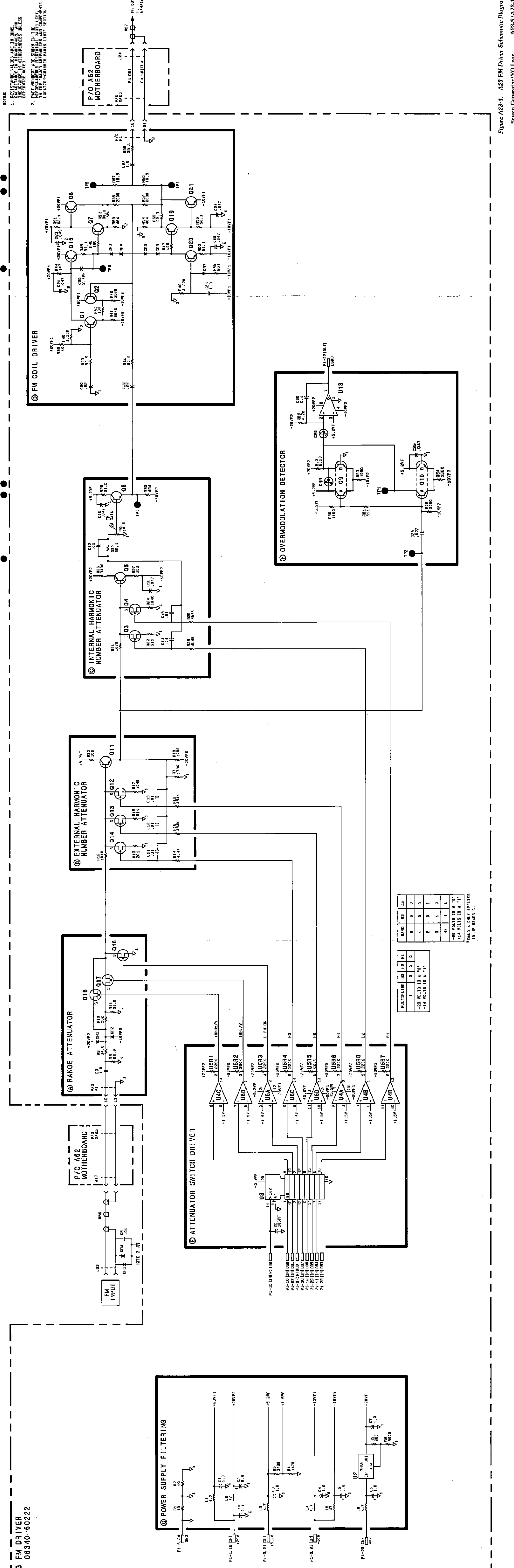

NOTES:
1. RESISTANCE VALUES ARE IN OHMS UNLESS INDICATED IN MICROHMS AND CAPACITANCE IN MICROSECONDS UNLESS OTHERWISE NOTED.
2. PART NUMBERS ARE SHOWN IN THE LIST OF PARTS AND COMPONENTS IN THE LOCATION-CHARACTERISTICS PARTS LIST SECTION.

MULTIPLIER	M3	M2	M1
1	0	0	0
-20 VOLTS IS A "0"	1	0	0
+14 VOLTS IS A "1"	2	0	1
	3	1	0
	4	1	1

BAND	B2	B1
0	0	0
1	0	0
2	0	1
3	1	0
4	1	1

* BAND 4 ONLY APPLIES TO HP 03400'S.

A23 FM Driver Component-Level Troubleshooting

Table A23-6. A23 FM Driver Replaceable Parts

Reference Designation	HP Part Number	C D	Qty	Description	Mfr Code	Mfr Part Number
A23	08340-60222	7	1	FM DRIVER ASSEMBLY	28480	08340-60222
A23C1	0160-4535	4	7	CAPACITOR-FXD 1UF ± 10% 50VDC CER	28480	0160-4535
A23C2	0160-0116	1	2	CAPACITOR-FXD 6.8UF ± 10% 35VDC TA	56289	150D685X9035B2
A23C3	0160-4535	4		CAPACITOR-FXD 1UF ± 10% 50VDC CER	28480	0160-4535
A23C4	0160-4535	4		CAPACITOR-FXD 1UF ± 10% 50VDC CER	28480	0160-4535
A23C5	0160-0116	1		CAPACITOR-FXD 6.8UF ± 10% 35VDC TA	56289	150D685X9035B2
A23C6	0160-2505	6	1	CAPACITOR-FXD 1UF ± 10% 75VDC TA	56289	150D105X9075B2
A23C7	0160-4535	4		CAPACITOR-FXD 1UF ± 10% 50VDC CER	28480	0160-4535
A23C8	0160-4389	6	1	CAPACITOR-FXD 100PF ± 5PF 200VDC CER	28480	0160-4389
A23C9	0160-4535	4		CAPACITOR-FXD 1UF ± 10% 50VDC CER	28480	0160-4535
A23C10				NOT ASSIGNED		
A23C11	0160-3879	7	5	CAPACITOR-FXD .01UF ± 20% 100VDC CER	02010	SR201C103MAA
A23C12	0160-3879	7		CAPACITOR-FXD .01UF ± 20% 100VDC CER	02010	SR201C103MAA
A23C13	0160-3879	7		CAPACITOR-FXD .01UF ± 20% 100VDC CER	02010	SR201C103MAA
A23C14	0160-3879	7		CAPACITOR-FXD .01UF ± 20% 100VDC CER	02010	SR201C103MAA
A23C15	0160-3879	7		CAPACITOR-FXD .01UF ± 20% 100VDC CER	02010	SR201C103MAA
A23C16	0160-0575	4	3	CAPACITOR-FXD .047UF ± 20% 50VDC CER	28480	0160-0575
A23C17	0160-3875	3	1	CAPACITOR-FXD 22PF ± 5% 200VDC CER 0 ± 30	28480	0160-3875
A23C18	0160-0575	4		CAPACITOR-FXD .047UF ± 20% 50VDC CER	28480	0160-0575
A23C19	0160-5098	6	4	CAPACITOR-FXD .22UF ± 10% 50VDC CER	16299	CAC05X7R224J050A
A23C20	0160-5098	6		CAPACITOR-FXD .22UF ± 10% 50VDC CER	16299	CAC05X7R224J050A
A23C21	0160-4819	7	2	CAPACITOR-FXD 2200PF ± 5% 100VDC CER	28480	0160-4819
A23C22	0160-4819	7		CAPACITOR-FXD 2200PF ± 5% 100VDC CER	28480	0160-4819
A23C23	0160-4823	1	2	CAPACITOR-FXD 3900PF ± 5% 100VDC CER	28480	0160-4823
A23C24	0160-4823	1		CAPACITOR-FXD 3900PF ± 5% 100VDC CER	28480	0160-4823
A23C25	0160-4619	5	1	CAPACITOR-FXD 2.7PF ± 25PF 200VDC CER	06352	FD12C0J2D2R7C
A23C26	0160-4535	4		CAPACITOR-FXD 1UF ± 10% 50VDC CER	28480	0160-4535
A23C27	0160-4535	4		CAPACITOR-FXD 1UF ± 10% 50VDC CER	28480	0160-4535
A23C28	0160-5098	6		CAPACITOR-FXD .22UF ± 10% 50VDC CER	16299	CAC05X7R224J050A
A23C29	0160-0575	4		CAPACITOR-FXD .047UF ± 20% 50VDC CER	28480	0160-0575
A23C30	0160-5098	6		CAPACITOR-FXD .22UF ± 10% 50VDC CER	16299	CAC05X7R224J050A
A23CR1	1901-0033	2	7	DIODE-GEN PRP 180V 200MA DO-7	28480	1901-0033
A23CR2	1901-0033	2		DIODE-GEN PRP 180V 200MA DO-7	28480	1901-0033
A23CR3	1901-0033	2		DIODE-GEN PRP 180V 200MA DO-7	28480	1901-0033
A23CR4	1901-0033	2		DIODE-GEN PRP 180V 200MA DO-7	28480	1901-0033
A23CR5	1901-0033	2		DIODE-GEN PRP 180V 200MA DO-7	28480	1901-0033
A23CR6	1901-0033	2		DIODE-GEN PRP 180V 200MA DO-7	28480	1901-0033
A23CR7	1901-0033	2		DIODE-GEN PRP 180V 200MA DO-7	28480	1901-0033
A23CR8	1901-0539	3	2	DIODE-SM SIG SCHOTTKY	28480	1901-0539
A23CR9	1901-0539	3		DIODE-SM SIG SCHOTTKY	28480	1901-0539
A23L1	9100-3562	8	5	INDUCTOR RF-CH-MLD 4.7UH 5% 166DX.385LG	28480	9100-3562
A23L2	9100-1629	4	2	INDUCTOR RF-CH-MLD 47UH 5% 166DX.385LG	28480	9100-1629
A23L3	9100-3562	8		INDUCTOR RF-CH-MLD 4.7UH 5% 166DX.385LG	28480	9100-3562
A23L4	9100-3562	8		INDUCTOR RF-CH-MLD 4.7UH 5% 166DX.385LG	28480	9100-3562
A23L5	9100-1629	4		INDUCTOR RF-CH-MLD 47UH 5% 166DX.385LG	28480	9100-1629
A23L6	9100-3562	8		INDUCTOR RF-CH-MLD 4.7UH 5% 166DX.385LG	28480	9100-3562
A23L7	9100-3562	8		INDUCTOR RF-CH-MLD 4.7UH 5% 166DX.385LG	28480	9100-3562
A23MP1	1480-0073	6	7	PIN-ROLL 082-IN-DIA 25-IN-LG BE-CU	28480	1480-0073
A23MP2	4040-0750	7	2	EXTR PC BD RED	28480	4040-0750
A23MP3	4040-0751	8	1	EXTR PC BD ORN	28480	4040-0751
A23MP4	1205-0037	0	1	HEAT SINK TO-18-CS	28480	1205-0037
A23MP5	1205-0011	0	3	HEAT SINK TO-5/TO-39-CS	28480	1205-0011
A23Q1	1854-0809	9	2	TRANSISTOR NPN 2N2369A SI TO-18 PD = 360MW	28480	1854-0809
A23Q2	1854-0809	9		TRANSISTOR NPN 2N2369A SI TO-18 PD = 360MW	28480	1854-0809
A23Q3	1855-0420	2	4	TRANSISTOR J-FET 2N4391 N-CHAN D-MODE	01295	2N4391
A23Q4	1855-0420	2		TRANSISTOR J-FET 2N4391 N-CHAN D-MODE	01295	2N4391
A23Q5	1853-0405	9	1	TRANSISTOR PNP SI PD = 300MW FT = 850MHZ	04713	2N4209
A23Q6	1854-0378	7	1	TRANSISTOR NPN 2N5109 SI TO-39 PD = 800MW	3L585	2N5109
A23Q7	1854-0401	7	3	TRANSISTOR NPN SI TO-72 PD = 200MW	28480	1854-0401
A23Q8	1853-0293	3	1	TRANSISTOR PNP 2N5583 SI TO-39 PD = 1W	04713	2N5583
A23Q9	1854-0295	7	2	TRANSISTOR-DUAL NPN PD = 400MW	28480	1854-0295
A23Q10	1854-0295	7		TRANSISTOR-DUAL NPN PD = 400MW	28480	1854-0295
A23Q11	1854-0401	7		TRANSISTOR NPN SI TO-72 PD = 200MW	28480	1854-0401
A23Q12	1855-0420	2		TRANSISTOR J-FET 2N4391 N-CHAN D-MODE	01295	2N4391
A23Q13	1855-0420	2		TRANSISTOR J-FET 2N4391 N-CHAN D-MODE	01295	2N4391
A23Q14	1855-0292	6	4	TRANSISTOR J-FET 2N5432 N-CHAN D-MODE	17856	2N5432
A23Q15	1853-0430	0	2	TRANSISTOR PNP 2N4959 SI TO-72 PD = 200MW	04713	2N4959

A23 FM Driver Component-Level Troubleshooting

Table A23-6. A23 FM Driver Replaceable Parts

Reference Designation	HP Part Number	C D	Qty	Description	Mfr Code	Mfr Part Number
A23Q16	1855-0292	6		TRANSISTOR J-FET 2N5432 N-CHAN D-MODE	17856	2N5432
A23Q17	1855-0292	6		TRANSISTOR J-FET 2N5432 N-CHAN D-MODE	17856	2N5432
A23Q18	1855-0292	6		TRANSISTOR J-FET 2N5432 N-CHAN D-MODE	17856	2N5432
A23Q19	1853-0430	0		TRANSISTOR PNP 2N4959 SI TO-72 PD-200MW	04713	2N4959
A23Q20	1854-0401	7		TRANSISTOR NPN SI TO-72 PD-200MW	28480	1854-0401
A23Q21	1854-0597	2	1	TRANSISTOR NPN 2N5943 SI TO-39 PD-1W	04713	2N5943
A23R1	0757-0346	2	10	RESISTOR 10 1% .125W F TC=0±100	24546	C4-1/8-T0-10R0-F
A23R2	0757-0346	2		RESISTOR 10 1% .125W F TC=0±100	24546	C4-1/8-T0-10R0-F
A23R3	0698-3152	8	3	RESISTOR 3.48K 1% .125W F TC=0±100	24546	C4-1/8-T0-3481-F
A23R4	0757-1094	9	3	RESISTOR 1.47K 1% .125W F TC=0±100	24546	C4-1/8-T0-1471-F
A23R5	0698-6377	5	1	RESISTOR 200 1% .125W F TC=0±25	28480	0698-6377
A23R6	0698-6348	0	2	RESISTOR 3K .1% .125W F TC=0±25	28480	0698-6348
A23R7	0757-0278	9	2	RESISTOR 1.78K 1% .125W F TC=0±100	24546	C4-1/8-T0-1781-F
A23R8	0757-1001	8	1	RESISTOR 56.2 1% 5W F TC=0±100	28480	0757-1001
A23R9	0698-3434	9	1	RESISTOR 34.8 1% .125W F TC=0±100	24546	C4-1/8-T0-34R8-F
A23R10	0698-0082	7	4	RESISTOR 464 1% .125W F TC=0±100	24546	C4-1/8-T0-4640-F
A23R11	0757-0276	7	1	RESISTOR 61.9 1% .125W F TC=0±100	24546	C4-1/8-T0-6192-F
A23R12	0698-6970	4	3	RESISTOR 1.04K 5% .125W F TC=0±50	28480	0698-6970
A23R13	0698-6970	4		RESISTOR 1.04K 5% .125W F TC=0±50	28480	0698-6970
A23R14	0698-3260	9	5	RESISTOR 464K 1% .125W F TC=0±100	02995	SFR25H
A23R15	0757-0416	7	7	RESISTOR 511 1% .125W F TC=0±100	24546	C4-1/8-T0-511R-F
A23R16	0698-3260	9		RESISTOR 464K 1% .125W F TC=0±100	02995	SFR25H
A23R17	0698-3132	4	1	RESISTOR 261 1% .125W F TC=0±100	24546	C4-1/8-T0-2610-F
A23R18	0698-3260	9		RESISTOR 464K 1% .125W F TC=0±100	02995	SFR25H
A23R19	0757-0278	9		RESISTOR 1.78K 1% .125W F TC=0±100	24546	C4-1/8-T0-1781-F
A23R20	0757-0401	0	6	RESISTOR 100 1% .125W F TC=0±100	24546	C4-1/8-T0-101-F
A23R21	0699-0794	0	1	RESISTOR 1.07K .1% .125W F TC=0±25	28480	0699-0794
A23R22	0698-6970	4		RESISTOR 1.04K 5% .125W F TC=0±50	28480	0698-6970
A23R23	0698-3260	9		RESISTOR 464K 1% .125W F TC=0±100	02995	SFR25H
A23R24	0757-0416	7		RESISTOR 511 1% .125W F TC=0±100	24546	C4-1/8-T0-511R-F
A23R25	0698-3260	9		RESISTOR 464K 1% .125W F TC=0±100	02995	SFR25H
A23R26	0698-3152	8		RESISTOR 3.48K 1% .125W F TC=0±100	24546	C4-1/8-T0-3481-F
A23R27	0757-0401	0		RESISTOR 100 1% .125W F TC=0±100	24546	C4-1/8-T0-101-F
A23R28	2100-3352	7	1	RESISTOR-TRMR 1K 10% C SIDE-ADJ 1-TRN	28480	2100-3352
A23R29	0698-3430	5	1	RESISTOR 21.5 1% .125W F TC=0±100	03888	PME55-1/8-T0-21R5-F
A23R30	0698-0082	7		RESISTOR 464 1% .125W F TC=0±100	24546	C4-1/8-T0-4640-F
A23R31	0698-3439	4	2	RESISTOR 178 1% .125W F TC=0±100	24546	C4-1/8-T0-178R-F
A23R32	0698-3441	8	2	RESISTOR 215 1% .125W F TC=0±100	24546	C4-1/8-T0-215R-F
A23R33	0698-3439	4		RESISTOR 178 1% .125W F TC=0±100	24546	C4-1/8-T0-178R-F
A23R34	0698-3441	8		RESISTOR 215 1% .125W F TC=0±100	24546	C4-1/8-T0-215R-F
A23R35	0698-3153	9	4	RESISTOR 3.83K 1% .125W F TC=0±100	24546	C4-1/8-T0-3831-F
A23R36	0698-6624	5	9	RESISTOR 2K .1% .125W F TC=0±25	28480	0698-6624
A23R37	0698-6624	5		RESISTOR 2K .1% .125W F TC=0±25	28480	0698-6624
A23R38	0757-0280	3	10	RESISTOR 1K 1% .125W F TC=0±100	24546	C4-1/8-T0-1001-F
A23R39	0698-6619	8	1	RESISTOR 15K .1% .125W F TC=0±25	28480	0698-6619
A23R40	0757-0438	3	7	RESISTOR 5.11K 1% .125W F TC=0±100	24546	C4-1/8-T0-5111-F
A23R41	0698-3151	7	2	RESISTOR 2.87K 1% .125W F TC=0±100	24546	C4-1/8-T0-2871-F
A23R42	0698-3151	7		RESISTOR 2.87K 1% .125W F TC=0±100	24546	C4-1/8-T0-2871-F
A23R43	0698-3440	7	1	RESISTOR 196 1% .125W F TC=0±100	24546	C4-1/8-T0-196R-F
A23R44	0698-3438	3	2	RESISTOR 147 1% .125W F TC=0±100	24546	C4-1/8-T0-147R-F
A23R45	0757-0394	0	3	RESISTOR 51.1 1% .125W F TC=0±100	24546	C4-1/8-T0-51R1-F
A23R46	0757-0401	0		RESISTOR 100 1% .125W F TC=0±100	24546	C4-1/8-T0-101-F
A23R47	0757-0401	0		RESISTOR 100 1% .125W F TC=0±100	24546	C4-1/8-T0-101-F
A23R48	0757-0439	4	3	RESISTOR 6.81K 1% .125W F TC=0±100	24546	C4-1/8-T0-6811-F
A23R49	0698-3438	3		RESISTOR 147 1% .125W F TC=0±100	24546	C4-1/8-T0-147R-F
A23R50	0698-3433	8	1	RESISTOR 28.7 1% .125W F TC=0±100	03888	PME55-1/8-T0-28R7-F
A23R51	0757-0397	3	2	RESISTOR 68.1 1% .125W F TC=0±100	24546	C4-1/8-T0-68R1-F
A23R52	0757-0400	9	2	RESISTOR 90.9 1% .125W F TC=0±100	24546	C4-1/8-T0-90R9-F
A23R53	0698-0082	7		RESISTOR 464 1% .125W F TC=0±100	24546	C4-1/8-T0-4640-F
A23R54	0698-0082	7		RESISTOR 464 1% .125W F TC=0±100	24546	C4-1/8-T0-4640-F
A23R55	0757-0400	9		RESISTOR 90.9 1% .125W F TC=0±100	24546	C4-1/8-T0-90R9-F
A23R56	0757-0397	3		RESISTOR 68.1 1% .125W F TC=0±100	24546	C4-1/8-T0-68R1-F
A23R57	0698-3429	2	2	RESISTOR 19.6 1% .125W F TC=0±100	03888	PME55-1/8-T0-19R6-F
A23R58	0698-3429	2		RESISTOR 19.6 1% .125W F TC=0±100	03888	PME55-1/8-T0-19R6-F
A23R59	0698-3396	2	1	RESISTOR 38.3 1% 5W F TC=0±100	28480	0698-3396
A23R60	0757-0424	7	1	RESISTOR 1.1K 1% .125W F TC=0±100	24546	C4-1/8-T0-1101-F

A23 FM Driver Component-Level Troubleshooting

Table A23-6. A23 FM Driver Replaceable Parts

Reference Designation	HP Part Number	C D	Qty	Description	Mfr Code	Mfr Part Number
A23R61	0757-0416	7		RESISTOR 511 1% .125W F TC=0±100	24546	C4-1/8-T0-511R-F
A23R62	0698-4433	0	1	RESISTOR 2.28K 1% .125W F TC=0±100	24546	C4-1/8-T0-2281-F
A23R63	0698-0083	8	6	RESISTOR 1.98K 1% .125W F TC=0±100	24546	C4-1/8-T0-1981-F
A23R64	0698-0083	8		RESISTOR 1.98K 1% .125W F TC=0±100	24546	C4-1/8-T0-1981-F
A23R65	0757-0439	4		RESISTOR 6.81K 1% .125W F TC=0±100	24546	C4-1/8-T0-6811-F
A23R66	0683-4755	8	1	RESISTOR 4.7M 5% .25W FC TC=-900/+1100	01121	CB4755
A23TP1	0360-0535	0	43	TERMINAL TEST POINT PCB	00000	ORDER BY DESCRIPTION
A23TP2	0360-0535	0		TERMINAL TEST POINT PCB	00000	ORDER BY DESCRIPTION
A23TP3	0360-0535	0		TERMINAL TEST POINT PCB	00000	ORDER BY DESCRIPTION
A23TP4	0360-0535	0		TERMINAL TEST POINT PCB	00000	ORDER BY DESCRIPTION
A23TP5	0360-0535	0		TERMINAL TEST POINT PCB	00000	ORDER BY DESCRIPTION
A23TP6	0360-0535	0		TERMINAL TEST POINT PCB	00000	ORDER BY DESCRIPTION
A23U1	1826-0026	3	1	IC COMPARATOR PRCN TO-99 PKG	01295	LM311L
A23U2	1826-0558	6	1	IC V RGLTR-ADJ-NEG 1 2/37V TO-39 PKG	27014	LM337H
A23U3	1820-1858	9	4	IC FF TTL LS D-TYPE OCTL	01295	SN74LS377N
A23U4	1826-0759	9	3	IC COMPARATOR GP QUAD 14-DIP-C PKG	04713	LM339J
A23U5	1810-0282	0	1	NETWORK-RES 10-SIP220.0K OHM X 9	01121	210A224
A23U6	1826-0759	9		IC COMPARATOR GP QUAD 14-DIP-C PKG	04713	LM339J

A47 Sense Resistor Assembly Circuit Description

ASSEMBLY PURPOSE

The A47 sense resistor assembly contains the high-power portions of both the A55 YO driver and the A28 SYTM driver. (For the schematic of the A47 sense resistor assembly, see schematics for A28 and A55.)

A47Q1, A47C1, and A47R6 are part of the compound PNP transistor in the voltage-to-current converter (block B) of the A55 YO driver, A47R6 is the sense resistor referred to in the A55 circuit description. A47Q2 and A47R1 through R5 are part of the A28 SYTM driver current driver (block H). For proper heat dissipation, these components are located a heat sink.

A47 Sense Resistor Assembly Component-Level Troubleshooting

Table A47-1. A47W2P1 to A62J32 Pin I/O

Pin	Mnemonic	A47W2P1	Levels
1	RGND	PIN 1	0V
2	SYTMDB	PIN 2	-22V TO -39V
3	SYTM COIL +	PIN 3	-40V TO -25V
4	SYTMDC	PIN 4	-.6V TO -6V
5	SYTMRES	PIN 5	-.9V LOW BAND CW

Note: Refer to A28 SYTM Driver Schematic Diagram and A62 motherboard wiring list for signal source and destination information.

Table A47-2. A47W1P1 to A62J29 Pin I/O

Pin	Mnemonic	A47W1P1	Levels
1	RGND	PIN 1	0V
2	SR FBK	PIN 2	-5V TO -17V
3	SR PWR	PIN 3	-5V TO -17V
4	YOXISTB	PIN 4	-30V TO -39V
5	YO COIL +	PIN 5	-40V TO -20V

Note: Refer to A55 YO Driver Schematic Diagram and A62 motherboard wiring list for signal source and destination information.

A47 Sense Resistor Assembly Component-Level Troubleshooting

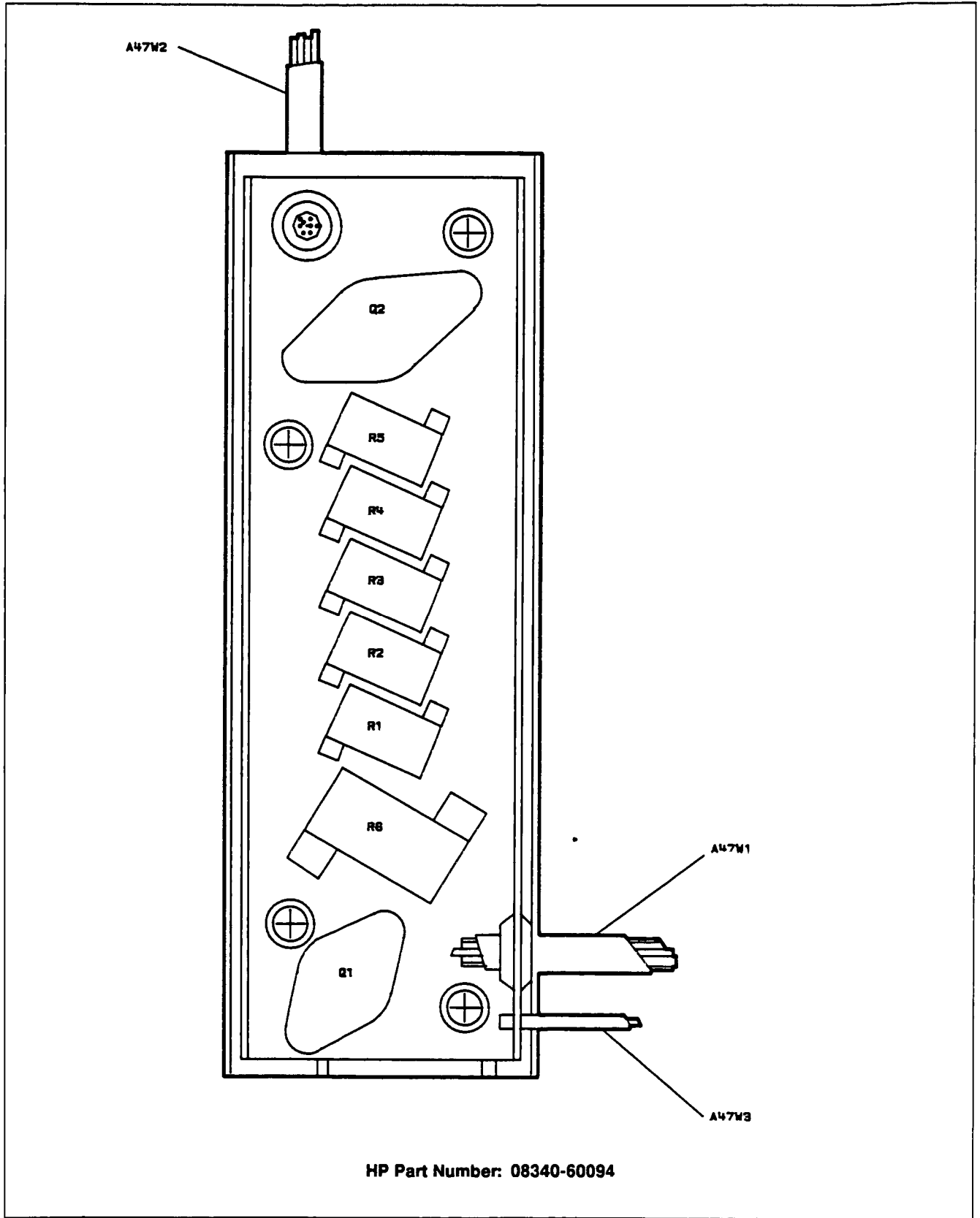

Figure A47-1. A47 Sense Resistor Assembly Component Location Diagram

A47 Sense Resistor Assembly Component-Level Troubleshooting

Table A47-3. A47 Sense Resistor Assembly Replaceable Parts

Reference Designation	HP Part Number	C D	Qty	Description	Mfr Code	Mfr Part Number
A47	08340-60094	1	1	SENSE RESISTOR ASSEMBLY NOTE: See Figure A47-2 for mechanical parts location	28480	08340-60094
A47C1	0160-4835	7	1	CAPACITOR-FXD .1UF ±10% 50VDC CER	28480	0160-4835
A47MP1	0340-0162	7	1	INSULATOR-XSTR ALUMINUM	28480	0340-0162
A47MP2	08340-60128	2	1	CBL AY SEN RES S	28480	08340-60128
A47MP3	0360-0268	6	1	TERMINAL-SLDR LUG LK-MTG FOR-#6-SCR	28480	0360-0268
A47MP4	08340-60129	3	1	CBL AY SEN RES L	28480	08340-60129
A47MP5	0400-0009	9	1	GROMMET-RND .125-IN-ID 25-IN-GRV-OD	28480	0400-0009
A47MP6	0400-0011	3	2	GROMMET-RND 375-IN-ID 5-IN-GRV-OD	28480	0400-0011
A47MP7	0400-0011	3		GROMMET-RND 375-IN-ID 5-IN-GRV-OD	28480	0400-0011
A47MP8	0520-0127	6	10	SCREW-MACH 2-56 .188-IN-LG PAN-HD-POZI	00000	ORDER BY DESCRIPTION
A47MP9	0520-0127	6		SCREW-MACH 2-56 .188-IN-LG PAN-HD-POZI	00000	ORDER BY DESCRIPTION
A47MP10	0520-0127	6		SCREW-MACH 2-56 .188-IN-LG PAN-HD-POZI	00000	ORDER BY DESCRIPTION
A47MP11	0520-0127	6		SCREW-MACH 2-56 .188-IN-LG PAN-HD-POZI	00000	ORDER BY DESCRIPTION
A47MP12	0520-0127	6		SCREW-MACH 2-56 .188-IN-LG PAN-HD-POZI	00000	ORDER BY DESCRIPTION
A47MP13	0520-0127	6		SCREW-MACH 2-56 .188-IN-LG PAN-HD-POZI	00000	ORDER BY DESCRIPTION
A47MP14	0520-0127	6		SCREW-MACH 2-56 .188-IN-LG PAN-HD-POZI	00000	ORDER BY DESCRIPTION
A47MP15	0520-0127	6		SCREW-MACH 2-56 .188-IN-LG PAN-HD-POZI	00000	ORDER BY DESCRIPTION
A47MP16	0520-0127	6		SCREW-MACH 2-56 .188-IN-LG PAN-HD-POZI	00000	ORDER BY DESCRIPTION
A47MP17	0520-0127	6		SCREW-MACH 2-56 .188-IN-LG PAN-HD-POZI	00000	ORDER BY DESCRIPTION
A47MP18	0624-0305	2	4	SCREW-TPG 6-20 .5-IN-LG PAN-HD-POZI	00000	ORDER BY DESCRIPTION
A47MP19	0624-0305	2		SCREW-TPG 6-20 .5-IN-LG PAN-HD-POZI	00000	ORDER BY DESCRIPTION
A47MP20	0624-0305	2		SCREW-TPG 6-20 .5-IN-LG PAN-HD-POZI	00000	ORDER BY DESCRIPTION
A47MP21	0624-0305	2		SCREW-TPG 6-20 .5-IN-LG PAN-HD-POZI	00000	ORDER BY DESCRIPTION
A47MP22	0890-0094	9	1	TUBING-FLEX .051-ID TFE .018-WALL	00000	ORDER BY DESCRIPTION
A47MP23	1200-0043	8	1	INSULATOR-XSTR ALUMINUM	28480	1200-0043
A47MP24	1200-0456	7	1	SOCKET-XSTR 2-CONT TO-3	28480	1200-0456
A47MP25	1200-0457	8	1	SOCKET-XSTR 2-CONT TO-68	28480	1200-0457
A47MP26-28	2190-0006	1	3	WASHER-LK HLCL NO 6 141-IN-ID	28480	2190-0006
A47MP29	2190-0014	1	10	WASHER-LK INTL T NO 2 089-IN-ID	28480	2190-0014
A47MP30	2190-0014	1		WASHER-LK INTL T NO 2 089-IN-ID	28480	2190-0014
A47MP31	2190-0014	1		WASHER-LK INTL T NO 2 089-IN-ID	28480	2190-0014
A47MP32	2190-0014	1		WASHER-LK INTL T NO 2 089-IN-ID	28480	2190-0014
A47MP33	2190-0014	1		WASHER-LK INTL T NO 2 089-IN-ID	28480	2190-0014
A47MP34	2190-0014	1		WASHER-LK INTL T NO 2 089-IN-ID	28480	2190-0014
A47MP35	2190-0014	1		WASHER-LK INTL T NO 2 089-IN-ID	28480	2190-0014
A47MP36	2190-0014	1		WASHER-LK INTL T NO 2 089-IN-ID	28480	2190-0014
A47MP37	2190-0014	1		WASHER-LK INTL T NO 2 089-IN-ID	28480	2190-0014
A47MP38	2190-0014	1		WASHER-LK INTL T NO 2 089-IN-ID	28480	2190-0014
A47MP39	2200-0103	2	2	SCREW-MACH 4-40 .25-IN-LG PAN-HD-POZI	00000	ORDER BY DESCRIPTION
A47MP40	2200-0103	2		SCREW-MACH 4-40 .25-IN-LG PAN-HD-POZI	00000	ORDER BY DESCRIPTION
A47MP41	2360-0113	2	2	SCREW-MACH 6-32 25-IN-LG PAN-HD-POZI	00000	ORDER BY DESCRIPTION
A47MP42	2360-0113	2		SCREW-MACH 6-32 25-IN-LG PAN-HD-POZI	00000	ORDER BY DESCRIPTION
A47MP43	2360-0203	1	4	SCREW-MACH 6-32 625-IN-LG PAN-HD-POZI	00000	ORDER BY DESCRIPTION
A47MP44	2360-0203	1		SCREW-MACH 6-32 625-IN-LG PAN-HD-POZI	00000	ORDER BY DESCRIPTION
A47MP45	2360-0203	1		SCREW-MACH 6-32 625-IN-LG PAN-HD-POZI	00000	ORDER BY DESCRIPTION
A47MP46	2360-0203	1		SCREW-MACH 6-32 625-IN-LG PAN-HD-POZI	00000	ORDER BY DESCRIPTION
A47MP47	3050-0003	3	4	WASHER-FL NM NO 6 141-IN-ID 375-IN-OD	28480	3050-0003
A47MP48	3050-0003	3		WASHER-FL NM NO 6 141-IN-ID 375-IN-OD	28480	3050-0003
A47MP49	3050-0003	3		WASHER-FL NM NO 6 141-IN-ID 375-IN-OD	28480	3050-0003
A47MP50	3050-0003	3		WASHER-FL NM NO 6 141-IN-ID 375-IN-OD	28480	3050-0003
A47MP51	3050-0005	5	4	WASHER-SHLDR NO 6 14-IN-ID 375-IN-OD	28480	3050-0005
A47MP52	3050-0005	5		WASHER-SHLDR NO 6 14-IN-ID 375-IN-OD	28480	3050-0005
A47MP53	3050-0005	5		WASHER-SHLDR NO 6 14-IN-ID 375-IN-OD	28480	3050-0005
A47MP54	3050-0005	5		WASHER-SHLDR NO 6 14-IN-ID 375-IN-OD	28480	3050-0005
A47MP55	3050-0227	3	4	WASHER-FL MTLC NO 6 149-IN-ID	28480	3050-0227
A47MP56	3050-0227	3		WASHER-FL MTLC NO 6 149-IN-ID	28480	3050-0227
A47MP57	3050-0227	3		WASHER-FL MTLC NO 6 149-IN-ID	28480	3050-0227
A47MP58	3050-0227	3		WASHER-FL MTLC NO 6 149-IN-ID	28480	3050-0227
A47MP59	6960-0016	0	4	PLUG-HOLE TR-HD FOR 125-D-HOLE NYL	28480	6960-0016
A47MP60	6960-0016	0		PLUG-HOLE TR-HD FOR 125-D-HOLE NYL	28480	6960-0016
A47MP61	6960-0016	0		PLUG-HOLE TR-HD FOR 125-D-HOLE NYL	28480	6960-0016
A47MP62	6960-0016	0		PLUG-HOLE TR-HD FOR 125-D-HOLE NYL	28480	6960-0016
A47MP63	08340-00033	2	1	BCKT CURRNT SENS	28480	08340-00033
A47MP64	08340-00046	7	1	BOX-CURRNT SENS	28480	08340-00046
A47MP65	08340-00048	9	1	MTG PLATE	28480	08340-00048

A47 Sense Resistor Assembly Component-Level Troubleshooting

Table A47-3. A47 Sense Resistor Assembly Replaceable Parts

Reference Designation	HP Part Number	C D	Qty	Description	Mfr Code	Mfr Part Number
A47Q1	1854-0237	7	1	TRANSISTOR NPN SI TO-86 PD=20W FT=10MHZ	28480	1854-0237
A47Q2	1854-0080	8	1	TRANSISTOR NPN SI TO-3 PD=100MW FT=300 MHZ	02037	SJ1515
A47R1	0811-3571	7	4	RESISTOR 60 1% 12W PW TC=0±2	28480	0811-3571
A47R2	0811-3571	7		RESISTOR 60 1% 12W PW TC=0±2	28480	0811-3571
A47R3	0811-3571	7		RESISTOR 60 1% 12W PW TC=0±2	28480	0811-3571
A47R4	0811-3571	7		RESISTOR 60 1% 12W PW TC=0±2	28480	0811-3571
A47R5	0811-1100	4	1	RESISTOR 3 1% 12W PW TC=0±5	28480	0811-1100
A47R6	0811-3597	7	1	RESISTOR 97.5 25% 25W PW TC = 0 ± 2	28480	0811-3597
A47W1	08340-60128	2	1	CBL AY SEN RES S	28480	08340-60128
A47W2	08340-60129	3	1	CBL AY SEN RES L	28480	08340-60129
A47W3	8151-0010	1	1	WIRE 16AWG 1X16	28480	8151-0010

A47 SENSE RESISTOR ASSEMBLY

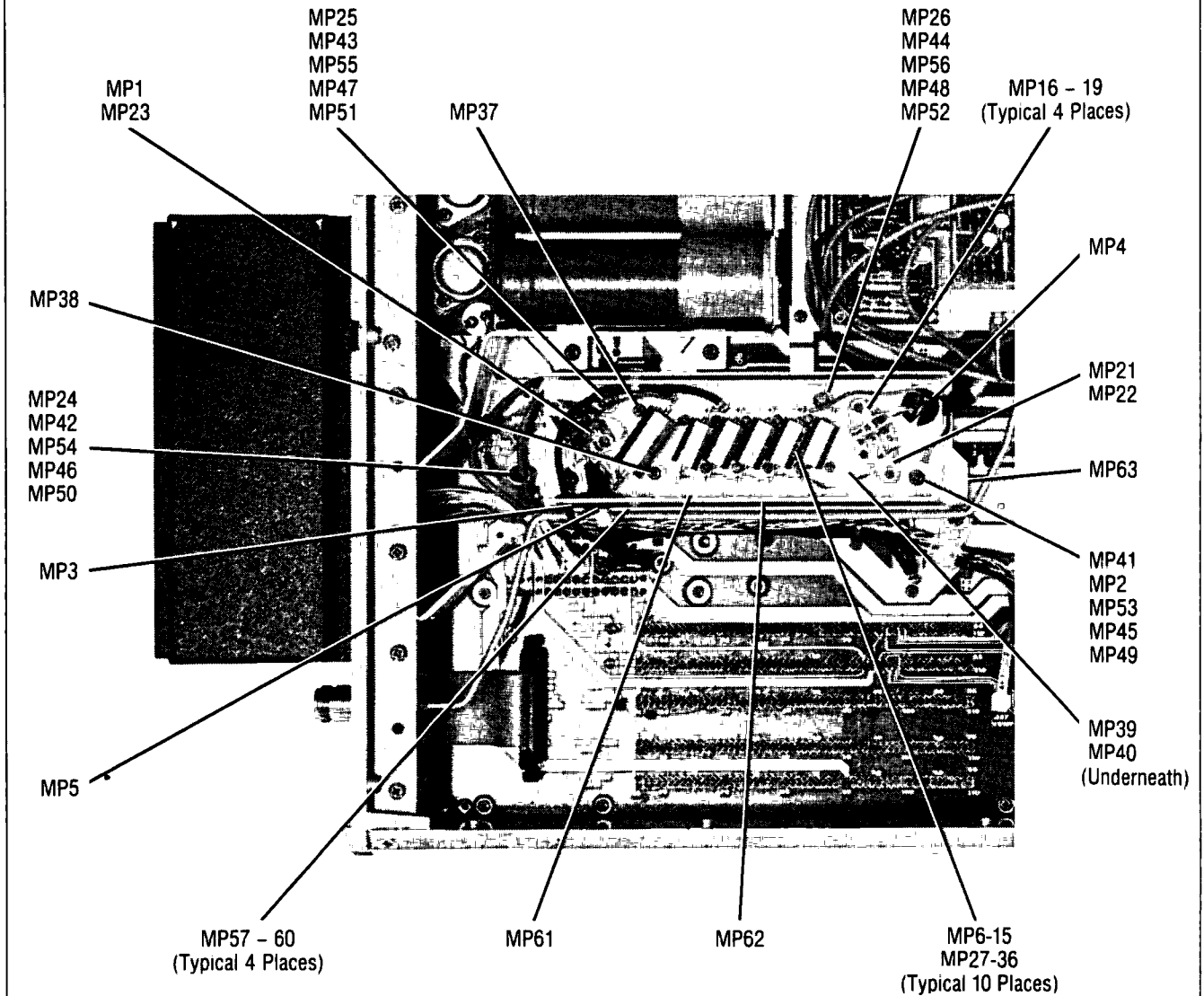

Figure A47-2. A47 Sense Resistor Assembly Mechanical Parts Location

A48 YO Loop Sampler Circuit Description

ASSEMBLY PURPOSE

The A48 YO Loop Sampler mixes the output of the A44 YIG oscillator (via the A45 directional coupler, AT2 15 dB attenuator and A46 7 GHz low pass filter) with the Nth harmonic of the output of the M/N-Reference Loop (M/N IN). The sampler IF output is a 20 to 30 MHz difference signal. It is output to the A49 YO loop phase detector where it is compared with the 20-30 MHz output from the A36 PLL1 VCO assembly. The A49 phase detector output is used to phase-lock the YO.

SAMPLER DRIVE AMPLIFIER (BLOCK A)

The output for the M/N-Reference Loop (M/N OUT) is connected to common-base amplifier Q3. The output of Q3 is ac-coupled to common-emitter amplifier Q8. The output of Q8 is sent through an impedance matching network to provide maximum drive power to A48U1 sampler. This impedance match is optimized by adjusting C1 and C2.

A48U1 SAMPLER (BLOCK B)

The sampler circuit contains a step recovery diode (SRD) that generates harmonics of the M/N signal. These harmonics are mixed with the low-level (-15 dBm) signal from the A44 YIG oscillator via the AT2 attenuator and the A46 7 GHz low pass filter (LPF).

When the YO Loop is phase-locked, the mixing product of the Nth harmonic of the M/N signal and the A44 YO signal is precisely equal to the 20-30 MHz signal from the A36 PLL1 VCO assembly.

IF PREAMPLIFIER (BLOCK C)

The IF preamplifier consists of common-source amplifier Q4, common-emitter amplifier Q2, and feedback divider R20/R16. The overall AC gain provided by this block is approximately 14 dB

BUFFER AMPLIFIER (BLOCK D) 70 MHz LOW-PASS FILTER (LPF) (BLOCK E)

The A48U1 sampler output is amplified, buffered by emitter-follower Q7, and filtered in the 70 MHz low-pass filter (block E). The filtering removes any unwanted mixing products from the sampler.

GAIN ADJUST (BLOCK F)

The 70 MHz low pass filter output is connected to a common-emitter amplifier Q6. The IF gain adjustment, R1, provides 5 to 20 dB of AC gain. This adjustment is used to set the IF signal to the proper level for comparison to the 20-30 signal in the A49 YO phase detector.

OUTPUT AMPLIFIER (BLOCK G)

The IF signal is amplified by approximately 21 dB in the output amplifier Q5 and Q1, and drives the A49 YO phase detector.

A48 YO Loop Sampler Component-Level Troubleshooting

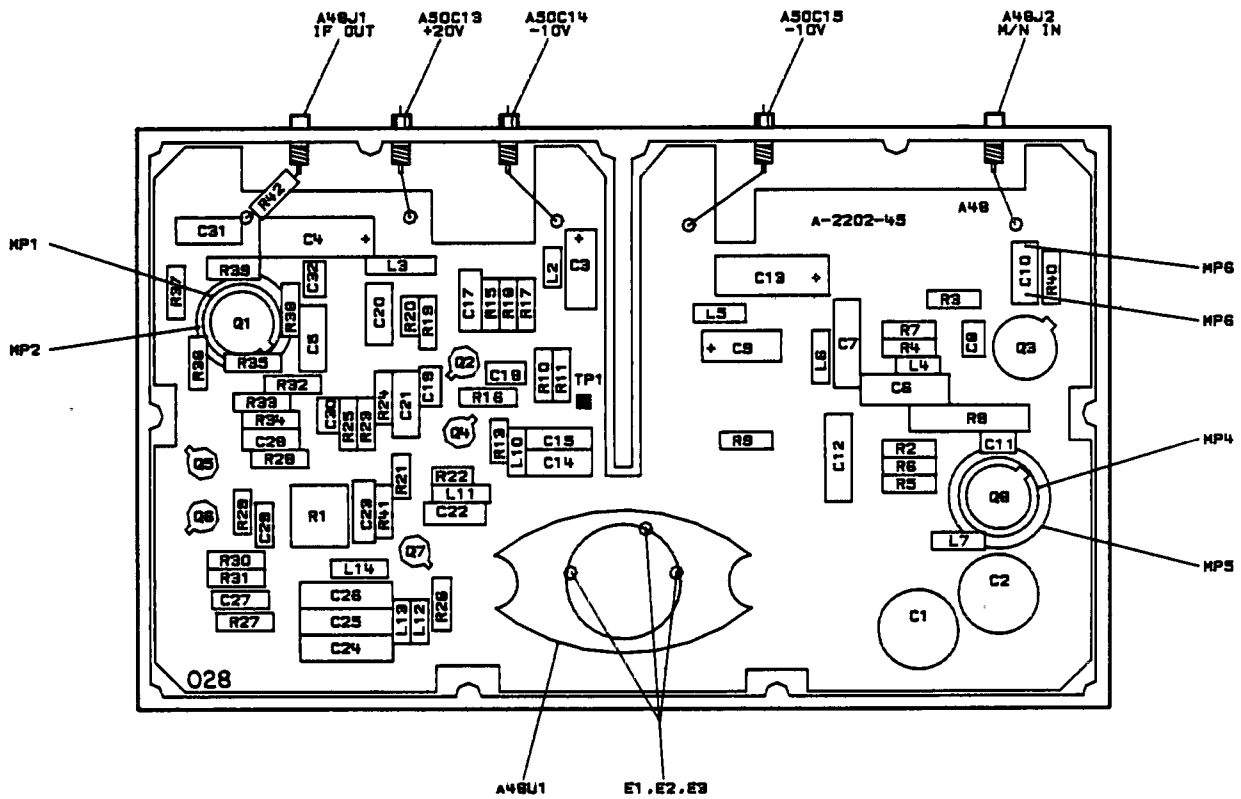

Not Separately Replaceable
 HP Part Number: 08340-60260

Figure A48-1. A48 YO Loop Sampler Component Location Diagram

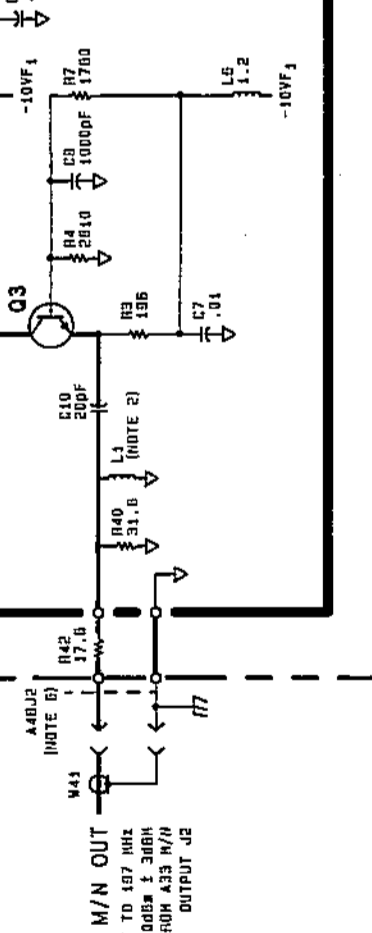
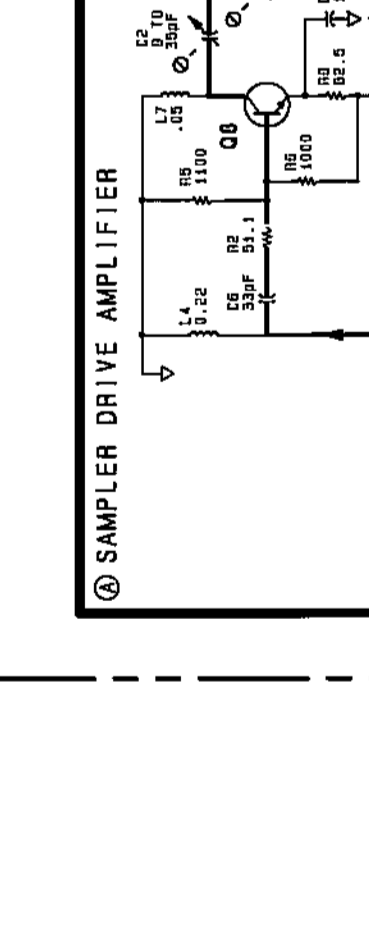
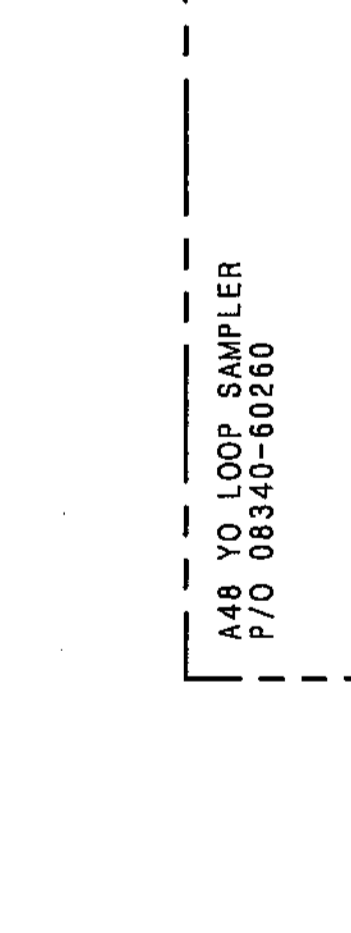
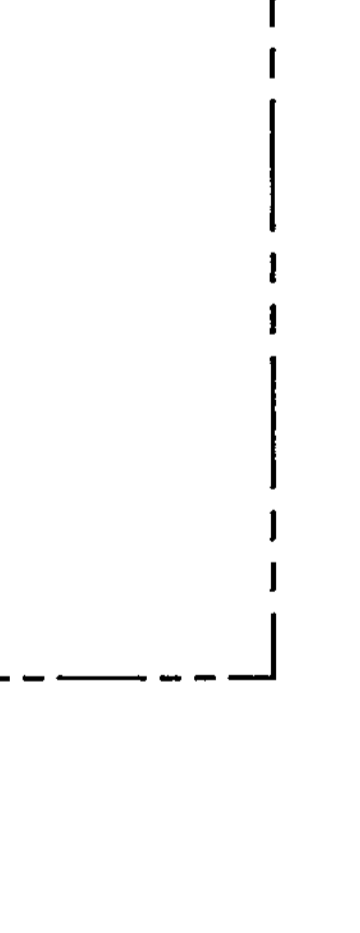
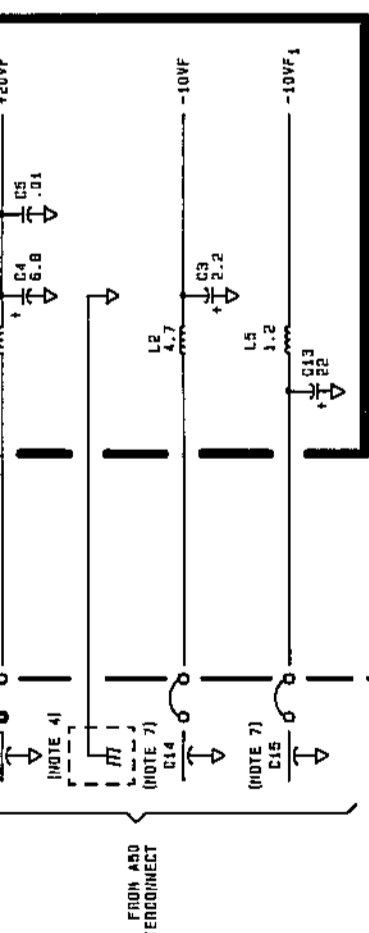

- NOTES:**
1. RESISTANCE VALUES ARE IN OHMS, CAPACITANCE IN MICROFARADS, AND INDUCTANCE IN MICROHENRIES UNLESS OTHERWISE NOTED.
 2. STRIP LINE INDUCTORS: L1: 0.0 IN. WIDE, 2.0 IN. LONG
L2: 0.1 IN. WIDE, 1.9 IN. LONG
L3: 0.1 IN. WIDE, 1.0 IN. LONG
 3. TYPICAL IF LEVELS MEASURED WITH A 5000 OHM PROBE OUTPUT LOAD AT 100MHZ UNLOADED SOURCE, WITH NORMAL OUTPUT LOAD AT 405.
 4. THE A48 AND A44 ASSEMBLY PC BOARDS ARE GROUNDED TO THE YO LOOP CASTING (CHARSIS GROUND) THROUGH THEIR MOUNTING HARDWARE. SEE NOTE 7.
 5. A48U1 SAMPLER MICROCIRCUIT IS MOUNTED ON A48 PC BOARD ASSEMBLY (UNDER THE HOUSING COVER).
 6. A48J1 AND A48K1 ARE NOT INCLUDED WITH THE 08340-60260 ASSEMBLY.
 7. A48U1, C10, C9 AND C10 CENTER CONDUCTORS ARE GROUNDED TO THE YO LOOP CASTING THROUGH SOLDERED BA GAUGE FINE WIRES. THEIR OUTER CONDUCTORS ARE ELECTRICALLY CONNECTED TO PC BOARD AND THE WIRE SHOULD BE CONNECTED TO THE CONNECTIONS IN THE ASSEMBLY MOUNTING HARDWARE.

*THIS PART NUMBER IS NOT ORDERABLE. REFER TO THE A48 PARTS LIST.

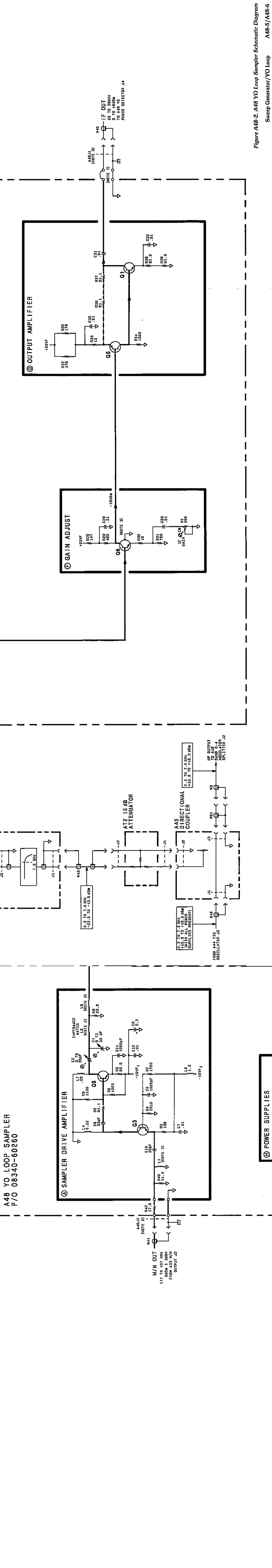

Figure A48-2. A48 YO Loop Sampler Schematic Diagram
Sweep Generator/YO Loop A48-5/A48-6

A48 YO Loop Sampler Component-Level Troubleshooting

Table A48-1. A48 YO Loop Sampler Replaceable Parts

Reference Designation	HP Part Number	C D	Qty	Description	Mfr Code	Mfr Part Number
A48			1	SAMPLER AMPIFIER, NOT SEPERATELY REPLACEABLE. ORDER 06340-60260 CD3 (INCLUDES A48, A49, AND HOUSING)		
A48C1	0121-0046	2	2	CAPACITOR-V TRMR-CER 9-35PF 200V PC-MTG	52763	304322 9/35PF N650
A48C2	0121-0046	2	2	CAPACITOR-V TRMR-CER 9-35PF 200V PC-MTG	52763	304322 9/35PF N650
A48C3	0180-0197	8	2	CAPACITOR-FXD 2.2UF ±10% 20VDC TA	56289	150D225X9020A2
A48C4	0180-0116	1	1	CAPACITOR-FXD 6.8UF ±10% 35VDC TA	56289	150D685X9035B2
A48C5	0160-2055	9	11	CAPACITOR-FXD .01UF +80-20% 100VDC CER	28480	0160-2055
A48C6	0160-2150	5	1	CAPACITOR-FXD 33PF ±5% 300VDC MICA	28480	0160-2150
A48C7	0160-2055	9	1	CAPACITOR-FXD .01UF +80-20% 100VDC CER	28480	0160-2055
A48C8	0160-3878	6	3	CAPACITOR-FXD 1000PF ±20% 100VDC CER	28480	0160-3878
A48C9	0180-0197	8	2	CAPACITOR-FXD 2.2UF ±10% 20VDC TA	56289	150D225X9020A2
A48C10	0160-2264	2	1	CAPACITOR-FXD 20PF ±5% 500VDC CER 0±30	28480	0160-2264
A48C11	0160-3878	6	1	CAPACITOR-FXD 1000PF ±20% 100VDC CER	28480	0160-3878
A48C12	0160-2055	9	1	CAPACITOR-FXD .01UF +80-20% 100VDC CER	28480	0160-2055
A48C13	0180-0228	8	1	CAPACITOR-FXD 22UF ±10% 15VDC TA	56289	150D228X9015B2
A48C14	0160-2055	9	1	CAPACITOR-FXD .01UF +80-20% 100VDC CER	28480	0160-2055
A48C15	0160-2055	9	1	CAPACITOR-FXD .01UF +80-20% 100VDC CER	28480	0160-2055
A48C16				NOT ASSIGNED		
A48C17	0160-2055	9	1	CAPACITOR-FXD .01UF +80-20% 100VDC CER	28480	0160-2055
A48C18	0160-3878	6	1	CAPACITOR-FXD 1000PF ±20% 100VDC CER	28480	0160-3878
A48C19	0160-3879	7	4	CAPACITOR-FXD .01UF ±20% 100VDC CER	28480	0160-3879
A48C20	0160-0939	4	1	CAPACITOR-FXD 430PF ±5% 300VDC MICA	28480	0160-0939
A48C21	0160-2055	9	1	CAPACITOR-FXD .01UF +80-20% 100VDC CER	28480	0160-2055
A48C22	0140-0195	2	1	CAPACITOR-FXD 130PF ±5% 300VDC MICA	72136	DM15F131J0300WV1CR
A48C23	0160-2055	9	1	CAPACITOR-FXD .01UF +80-20% 100VDC CER	28480	0160-2055
A48C24	0140-0193	0	2	CAPACITOR-FXD 82PF ±5% 300VDC MICA	72136	DM15E820J0300WV1CR
A48C25	0140-0193	0	0	CAPACITOR-FXD 82PF ±5% 300VDC MICA	72136	DM15E820J0300WV1CR
A48C26	0160-2308	5	1	CAPACITOR-FXD 36PF ±5% 300VDC MICA	28480	0160-2308
A48C27	0160-2055	9	1	CAPACITOR-FXD .01UF +80-20% 100VDC CER	28480	0160-2055
A48C28	0160-2055	9	1	CAPACITOR-FXD .01UF +80-20% 100VDC CER	28480	0160-2055
A48C29	0160-3879	7	1	CAPACITOR-FXD .01UF ±20% 100VDC CER	28480	0160-3879
A48C30	0160-3879	7	1	CAPACITOR-FXD .01UF ±20% 100VDC CER	28480	0160-3879
A48C31	0160-2055	9	1	CAPACITOR-FXD .01UF +80-20% 100VDC CER	28480	0160-2055
A48C32	0160-3879	7	1	CAPACITOR-FXD .01UF ±20% 100VDC CER	28480	0160-3879
A48E1	1251-3172	7	3	CONNECTOR-SGL CONT SKT .03-IN-BSC-SZ RND	28480	1251-3172
A48E2	1251-3172	7	3	CONNECTOR-SGL CONT SKT .03-IN-BSC-SZ RND	28480	1251-3172
A48E3	1251-3172	7	3	CONNECTOR-SGL CONT SKT .03-IN-BSC-SZ RND	28480	1251-3172
A48J1				SEE "MISCELLANEOUS YO LOOP PARTS" AT THE END OF TABLE 6-3		
A48J2				SEE "MISCELLANEOUS YO LOOP PARTS" AT THE END OF TABLE 6-3		
A48L1				STRIP LINE ON P. C. BOARD		
A48L2	9140-0144	0	1	INDUCTOR RF-CH-MLD 4.7UH 10% 105DX 26LG	28480	9140-0144
A48L3	9100-1623	8	1	INDUCTOR RF-CH-MLD 27UH 5% 166DX 385LG	28480	9100-1623
A48L4	9100-2251	0	1	INDUCTOR RF-CH-MLD 220NH 10% 105DX 26LG	28480	9100-2251
A48L5	9100-2258	7	2	INDUCTOR RF-CH-MLD 1.2UH 10% 105DX 26LG	28480	9100-2258
A48L6	9100-2258	7	1	INDUCTOR RF-CH-MLD 1.2UH 10% 105DX 26LG	28480	9100-2258
A48L7	9135-0073	3	1	INDUCTOR RF-CH-MLD 51NH 6% 102DX 26LG (RECOMMENDED REPLACEMENT)	28480	9135-0073
A48L8, 9				STRIP LINE ON P. C. BOARD		
A48L10	9140-0539	7	1	INDUCTOR RF-CH-MLD 3UH 5% 105DX 26LG	28480	9140-0539
A48L11	9100-0368	6	1	INDUCTOR RF-CH-MLD 330NH 10% 105DX 26LG	28480	9100-0368
A48L12	9100-2249	6	2	INDUCTOR RF-CH-MLD 150NH 10% 105DX 26LG	28480	9100-2249
A48L13	9100-2250	9	1	INDUCTOR RF-CH-MLD 180NH 10% 105DX 26LG	28480	9100-2250
A48L14	9100-2249	6	2	INDUCTOR RF-CH-MLD 150NH 10% 105DX 26LG	28480	9100-2249
A48MP1				NOT ASSIGNED		
A48MP2	1205-0011	0	2	HEAT SINK TO-5/TO-39-CS	28480	1205-0011
A48MP3				NOT ASSIGNED		
A48MP4				NOT ASSIGNED		
A48MP5	1205-0011	0	2	HEAT SINK TO-5/TO-39-CS	28480	1205-0011
A48MP6, 7	4330-0145	9	2	INSULATOR-BEAD GLASS	28480	4330-0145
A48Q1	1854-0247	9	3	TRANSISTOR NPN SI TO-39 PD = 1W FT = 800MHZ	28480	1854-0247
A48Q2	1854-0345	8	3	TRANSISTOR NPN 2N5179 SI TO-72 PD = 200MW	04713	2N5179
A48Q3	1854-0247	9	3	TRANSISTOR NPN SI TO-39 PD = 1W FT = 800MHZ	28480	1854-0247
A48Q4	1855-0235	7	1	TRANSISTOR J-FET N-CHAN D-MODE TO-52 SI	28480	1855-0235
A48Q5	1853-0015	7	1	TRANSISTOR PNP SI PD = 200MW FT = 500MHZ	28480	1853-0015

A48 YO Loop Sampler Component-Level Troubleshooting

Table A48-1. A48 YO Loop Sampler Replaceable Parts

Reference Designation	HP Part Number	C D	Qty	Description	Mfr Code	Mfr Part Number
A48Q6	1854-0345	8		TRANSISTOR NPN 2N5179 SI TO-72 PD=200MW	04713	2N5179
A48Q7	1854-0345	8		TRANSISTOR NPN 2N5179 SI TO-72 PD=200MW	04713	2N5179
A48Q8	1854-0247	9		TRANSISTOR NPN SI TO-39 PD=1W FT=800MHZ	28480	1854-0247
<p>NOTE: A48R1, R28, and R29 must be replaced at the same time</p>						
A48R1	2100-3212	8	1	RESISTOR-TRMR 200 10% C TOP-ADJ 1-TRN (RECOMMENDED REPLACEMENT)	28480	2100-3212
A48R2	0757-0394	0	5	RESISTOR 51.1 1% .125W F TC=0±100	24546	C4-1/8-T0-51R1-F
A48R3	0698-3440	7	1	RESISTOR 196 1% .125W F TC=0±100	24546	C4-1/8-T0-196R-F
A48R4	0698-0085	0	1	RESISTOR 2 61K 1% .125W F TC=0±100	24546	C4-1/8-T0-2611-F
A48R5	0757-0424	7	3	RESISTOR 1.1K 1% .125W F TC=0±100	24546	C4-1/8-T0-1101-F
A48R6	0757-0280	3	3	RESISTOR 1K 1% .125W F TC=0±100	24546	C4-1/8-T0-1001-F
A48R7	0757-0278	9	1	RESISTOR 1.78K 1% .125W F TC=0±100	24546	C4-1/8-T0-1781-F
A48R8	0757-0796	6	1	RESISTOR 82.5 1% .5W F TC=0±100	28480	0757-0796
A48R9	0757-0399	5	1	RESISTOR 82.5 1% .125W F TC=0±100	24546	C4-1/8-T0-82R5-F
A48R10	0698-3457	6	1	RESISTOR 316K 1% .125W F TC=0±100	28480	0698-3457
A48R11	0757-0470	3	1	RESISTOR 162K 1% .125W F TC=0±100	24546	C4-1/8-T0-1623-F
A48R12				NOT ASSIGNED		
A48R13	0698-7216	3	1	RESISTOR 147 1% .05W F TC=0±100	24546	C3-1/8-T0-147R-F
A48R14				NOT ASSIGNED		
A48R15	0757-0424	7		RESISTOR 1.1K 1% .125W F TC=0±100	24546	C4-1/8-T0-1101-F
A48R16	0757-0398	4	1	RESISTOR 75 1% .125W F TC=0±100	24546	C4-1/8-T0-75R0-F
A48R17	0757-0424	7		RESISTOR 1.1K 1% .125W F TC=0±100	24546	C4-1/8-T0-1101-F
A48R18	0757-0419	0	1	RESISTOR 681 1% .125W F TC=0±100	24546	C4-1/8-T0-681R-F
A48R19	0757-0421	4	1	RESISTOR 825 1% .125W F TC=0±100	24546	C4-1/8-T0-825R-F
A48R20	0698-7224	3	1	RESISTOR 316 1% .05W F TC=0±100	24546	C3-1/8-T0-316R-F
A48R21	0698-7212	9	1	RESISTOR 100 1% .05W F TC=0±100	24546	C3-1/8-T0-100R-F
A48R22	0698-7195	7	1	RESISTOR 19.6 1% .05W F TC=0±100	24546	C3-1/8-T0-19R6-F
A48R23	0698-0083	8	1	RESISTOR 1.96K 1% .125W F TC=0±100	24546	C4-1/8-T0-1961-F
A48R24	0698-0084	9	1	RESISTOR 2 15K 1% .125W F TC=0±100	24546	C4-1/8-T0-2151-F
A48R25	0698-0082	7	1	RESISTOR 464 1% .125W F TC=0±100	24546	C4-1/8-T0-4640-F
A48R26	0757-0280	3		RESISTOR 1K 1% .125W F TC=0±100	24546	C4-1/8-T0-1001-F
A48R27	0757-0394	0		RESISTOR 51.1 1% .125W F TC=0±100	24546	C4-1/8-T0-51R1-F
A48R28	0698-3438	3	1	RESISTOR 147 1% .125W F TC=0±100 (RECOMMENDED REPLACEMENT)	24546	C4-1/8-T0-147R-F
A48R29	0698-3447	4	1	RESISTOR 422 1% .125W F TC=0±100 (RECOMMENDED REPLACEMENT)	24546	C3-1/8-T0-422R-F
A48R30	0757-0346	2	2	RESISTOR 10 1% .125W F TC=0±100	24546	C4-1/8-T0-10R0-F
A48R31	0757-0420	3	1	RESISTOR 750 1% .125W F TC=0±100	24546	C4-1/8-T0-751-F
A48R32	0698-3439	4	2	RESISTOR 178 1% .125W F TC=0±100	24546	C4-1/8-T0-178R-F
A48R33	0757-0346	2		RESISTOR 10 1% .125W F TC=0±100	24546	C4-1/8-T0-10R0-F
A48R34	0757-0280	3		RESISTOR 1K 1% .125W F TC=0±100	24546	C4-1/8-T0-1001-F
A48R35	0698-3439	4		RESISTOR 178 1% .125W F TC=0±100	24546	C4-1/8-T0-178R-F
A48R36	0757-0394	0		RESISTOR 51.1 1% .125W F TC=0±100	24546	C4-1/8-T0-51R1-F
A48R37	0757-0394	0		RESISTOR 51.1 1% .125W F TC=0±100	24546	C4-1/8-T0-51R1-F
A48R38	0757-0276	7	2	RESISTOR 61.9 1% .125W F TC=0±100	24546	C4-1/8-T0-6192-F
A48R39	0757-0276	7		RESISTOR 61.9 1% .125W F TC=0±100	24546	C4-1/8-T0-6192-F
A48R40	0757-0189	2		RESISTOR 31.6 1% .125W F TC=0±100	24546	C4-1/8-T0-31R6-F
A48R41	0698-7196	8	1	RESISTOR 21.5 1% .05W F TC=0±100	24546	C3-1/8-T0-21R5-F
A48R42	0757-0294	9	1	RESISTOR 17.8 1% .125W F TC=0±100	24546	C4-1/8-T0-17R8-F
A48TP1	0360-0535	0	1	TERMINAL TEST POINT PCB	00000	ORDER BY DESCRIPTION
A48U1	5086-7292	3	1	SAMPLER	28480	5086-7292

A49 YO Loop Phase Detector Circuit Description

ASSEMBLY PURPOSE

Sampler IF signal (from the A48 YO loop sampler) and the 20-30 MHz signal (from the A36 PLL1 VCO) are inputs to the A49 YO loop phase detector assembly. These signals are phase-compared and the result is integrated to produce the following signals:

- YO TUNE
- FM Coil Drive
- High Unlock YO (HULY)

The A54 YO pretune/delay compensation assembly generates the PRETUNE voltage required to tune the A44 YO main coil to approximately the desired frequency. A portion of the YO output is coupled back to the sampler (A48U1) where the YO signal is mixed with the Nth harmonic of the output of the A33 M/N Output assembly. This generates a difference signal of 20 to 30 MHz (Sampler IF) that is input to the A49 YO loop phase detector. The A49 assembly then phase compares the difference signal to the 20-30 MHz reference signal from the A36 PLL1 VCO. The resulting error signal tunes the YO to achieve phase-lock.

The YO frequency is related to the M/N Output frequency and the 20-30 MHz reference loop frequency in the following manner:

$$F_{YO} = (N)(F_{M/N}) - F_{20-30}$$

Where:

F_{YO} = YO output frequency (MHz)

N = N number input to the M/N Loop (harmonic near the frequency to which the YO loop is tuned)

$F_{M/N}$ = M/N loop output frequency (MHz)

F_{20-30} = 20-30 loop output frequency (MHz) (the 20-30 frequency can be changed in 1 Hz steps)

The YO TUNE output from the A49 YO loop phase detector board goes to the A55 YO driver where it is summed with the PRETUNE voltage from the A54 YO pretune/delay compensation assembly. This sum is then applied to the YO main coil. The YO FM coil drive from the A49 YO loop phase detector assembly goes to the A44A1 YO bias assembly and then to the YO FM coil.

70 MHz LOW-PASS FILTER (BLOCK A)

The 20-30 MHz IF OUT from the A48 YO loop sampler is connected to the 70 MHz low pass filter. The filter removes any unwanted frequencies that may have been introduced during the sampling process.

IF LIMITER (BLOCK B)

20-30 LIMITER (BLOCK C)

Each of the two input signals, sampler IF and 20-30 REF, are passed through a limiter to establish ECL signal levels and to sharpen the edges of the two signals (ECL high = approximately -0.9V ECL low = -1.8V). Measure the limited sampler IF at TP5; measure the limited 20-30 signal at TP4.

PHASE/FREQUENCY DETECTOR (BLOCK D)

The two limited signals, Sampler IF and 20-30 REF, are applied to binary divider U8, which drives the phase/frequency detector U5. U5 outputs a pulse that is related to the phase and frequency difference of the two input signals. The width of this pulse is directly proportional to the amount of phase and frequency difference. When the two signals are at the same frequency, the output is proportional to the difference in phase. If the sampler IF signal leads the 20-30 REF signal, a negative pulse appears at U5 pin 12 (TP2), the width is proportional to the amount of phase difference. If the 20-30 REF signal leads the sampler IF signal, a negative pulse appears at U5 pin 3 (TP3). In each case, the other output pin remains ECL high (approximately -0.9V). If the inputs are in phase, one of the detector outputs is ECL high with long narrow negative spikes and the other is ECL high with short spikes. The detector outputs are averaged in a 2.0 MHz low pass filter (L8, L9, C15, C16) before being applied to the loop integrators.

FM OVERMODULATION DETECTOR (BLOCK E)

The FM overmodulation detector indicates when the phase difference between the sampler IF input and 20-30 MHz input exceeds approximately 300° . Phase excursions greater than this can cause the phase lock loop to become unlocked.

Pins 4 and 11 of phase detector U5 are connected together in a hard-wired OR gate configuration. If the two inputs are exactly in phase, both pins 4 and 11 are constantly at an ECL low level (-1.8V). When they are not precisely in phase, either pin 4 or 11 will output positive pulses, depending on which input leads the other. Because the width of the pulses is proportional to the phase difference, after passing through the 5 MHz low pass filter, a DC voltage is produced (TP1) that varies with the phase difference.

Q1 forms a fast comparator, adjusted by R32, conducts current when the phase exceeds approximately 300° . The current pulse charges C33 via CR1, establishing a fast attack/slow decay response. The resulting negative voltage on C33 trips U7, pulling LOMD low (TTL).

Because certain normal operating modes trigger the overmod detector, causing erroneous OVERMOD indications, the overmod detector is disabled under the following conditions:

- When the YO loop is unlocked, the overmod detector is disabled via the HULY (high unLock YO) signal coming in through R52. Q1A is biased on by the increase in voltage on its base, sinking current away from Q1B and allowing pin 2 of U7 to go higher than 0V. This causes the output of U7 to go high.
- When the instrument is phase-locking, the overmod detector is disabled via the HSP (high sweep) signal coming into CR3, U2B, and R33. (HSP is TTL low during phase-locking and high during sweep and in CW mode.)

- When the instrument is swept across a frequency range greater than 5 MHz (YO is unlocked), HLEY (high lock enable, YO loop) disables the overmod detector via R46. When the YO is unlocked during a sweep greater than 5 MHz, the maximum phase deviation between the two inputs is not important.

LOOP INTEGRATORS (BLOCK F)

Integrators U4 and U3 are used in conjunction with a phase-lag filter to help fine-tune the frequency of the YO.

The loop integrators produce a voltage that is proportional to the YO output frequency error. This voltage is actually a DC voltage with a very small AC component. This AC component looks like noise on the DC output. This voltage is used by the sample and hold & FM coil driver circuits to compensate for two major YO inaccuracies:

1. The PRETUNE signal is not capable of perfectly tuning the YO due to PRETUNE circuit resolution, circuit drift, and other causes. This fixed YO frequency error shows up as a DC output from the Loop Integrators.
2. System noise that affects the YO shows up as a very small AC component superimposed on the DC output of the integrators. The AC component provides error correction via the sample and hold circuit, or via the FM coil driver, depending on the AC component's frequency. (The sample and hold circuit drives the YO's main coil, which can only handle frequencies of 100 Hz and below. The FM Coil Driver drives the YO's FM coil, which is able to respond to higher frequencies.)

R18 is a selected resistor which may be adjusted upward in value to reduce the YO loop bandwidth or downward to increase the YO loop bandwidth.

If the A55 YO driver assembly is misadjusted (offset and gain adjustments), there is a DC offset voltage at the integrator output. There is normally a small offset at any given frequency due to non-linearities in the YO tracking, but the value should vary about zero volts. If the average value is different from zero, it will limit the loop capture range.

TEST JUMPER (BLOCK G)

The test jumper provides a way to break the YO loop and insert a test fixture to measure the loop gain, bandwidth, and phase margin.

AN OVERVIEW OF THE SAMPLE AND HOLD AND FM COIL DRIVER

The sample and hold, and the FM coil driver, perform similar tasks, both provide the YO with frequency error correction. The sample and hold's output affects the YO's main tuning coil and the FM coil driver's output goes to the YO's FM coil. The difference between the two circuits is described below. Both circuits receive a DC voltage with a very small AC component superimposed on it (refer to the loop integrators description, above):

Sample and Hold

The sample and hold responds to the DC component of the loop integrator's output signal. The sample and hold also responds to the superimposed AC (noise correction) signal. If the AC signal's frequency is 100 Hz or less, however, subsequent circuitry (on the A55 YO driver) filters the correction signal out, because the main YO coil cannot respond to frequencies greater than 100 Hz.

FM Coil Driver

The FM coil driver only responds to incoming AC signals at or above 100 Hz. Due to the FM coils smaller size, it provides YO noise error corrections at frequencies above the capability of the main YO coil. The FM coil has faster response than the YO main coil.

Both circuits provide frequency error correction when the YO is phase-locked. When the YO is being swept, the sample and hold goes into hold mode, and the FM coil driver's input is off. This defeats error correction in both circuits, but is necessary for the following reasons:

- To keep the sample and hold & FM coil driver from trying to cancel the sweep.
- To prevent the production of spurious sidebands.

SAMPLE AND HOLD (BLOCK H)

The sample and hold (U6 and associated circuitry) applies the integrated output of the phase-detector to the YO to tune the YO and achieve phase-lock. If the YO is swept greater than 5 MHz, it holds this DC voltage during the sweep to improve the swept frequency accuracy. This operation is commonly referred to as lock and sweep.

This circuit, when in the sample mode, provides YO frequency error correction. See the sample and hold & FM coil driver overview for error correction specifics.

The sample and hold has two modes of operation:

1. **Sample Mode.** This is the no-memory mode where the input to the sample and hold circuit is used directly to tune and phase-lock the YO. This mode occurs when:
 - a. The instrument is in the CW/MANUAL mode, or is in the swept mode and the YO is swept 5 MHz or less. Under the latter condition, the YO is phase-locked during the entire sweep.
 - b. Just prior to a sweep in which the YO will be swept greater than 5 MHz, the YO TUNE signal tunes and phase-locks the YO at the beginning of each sweep. Just before the actual sweep begins, the sample and hold circuit switches to the hold mode. This phase lock is repeated at each bandcrossing.

2. Hold Mode — The hold mode only occurs when the YO sweep will be greater than 5 MHz. After the YO locking signal is sampled (charging C24) at the beginning of sweep, the hold mode is enabled. This mode uses the voltage stored across C24 to provide a fixed YO TUNE reference voltage to the YO's main tuning coil. The signal is summed with other signals in order to drive the YO's main coil. Full error correction occurs during the initial sample (this allows the YO to compensate for PRETUNE inaccuracy), but other small errors (from system noise, etc) are no longer corrected when hold mode begins.

The operating mode of U6 is selected by the control signal LLEY (Low=Lock Enabled, YO) which comes from the logic inverter/translator, block L. When this signal is at $-5V$, the sample mode is enabled. When LLEY is at $0V$, the hold mode is enabled.

FM COIL DRIVER (BLOCK I)

The FM coil driver provides the tune signal for the YO FM Coil. This circuit provides YO frequency error correction when Q2 is ON (only when the YO is phase-locked). This circuit only accepts the AC component (which looks like noise superimposed on a DC level) from the loop integrators' output, and then only if the AC component's frequency is 100 Hz or above. Error correction with AC frequencies below 100 Hz is accomplished by the sample and hold circuit (block H), described above. The FM coil driver consists of two parts:

- 100 Hz High Pass Filter. This filter allows only the high frequency portion (greater than 100 Hz) of the error signal to be applied to the YO FM Coil. There is also a ground transformation (provided by C26, R20, and R22) from Reference ground to FM GND.
- Output Amplifier. This circuit amplifies and filters the high frequency portion of the error signal to provide the drive current (through R27) to the YO FM Coil. A phase-lag filter in the amplifier's feedback path completes the YO Loop's frequency response and improves noise rejection. The output voltage signal is clamped (by VR4 and VR3) to a maximum of $\pm 6.2V$ to prevent the operational amplifier from becoming saturated during phase-lock.

The resistor-capacitor combination of R25-C28 and R26-C29 are used to provide additional filtering of the power supply inputs to A49U1.

UNLOCKED DETECTORS (BLOCK J)

The output of integrator U3 in loop integrators (block F) is a voltage representing the amount of frequency or phase error between the YO actual output and what it is supposed to be (based on the M/N and 20-30 Loop frequencies). This output voltage is presented to the comparators of the unlock detector.

Comparator U2C compares the output to $-5.9V$. Comparator U2D compares the output to $+5.9V$.

When the input to the unlock detector circuit exceeds approximately $\pm 5.9V$, the output of U2D goes open, allowing HULY to be pulled up to $+4.64V$ (where it is clamped by zener diode VR6). HULY is monitored by the instrument's processor, which activates the UNLK annunciator on the front panel. The HULY signal also causes an LED on the A50 YO loop interconnect board to go out when an unlocked condition exists.

When the output of the loop integrators (block F) is within approximately $\pm 5.9V$, the output of comparator U2D is pulled down to $-10V$. The HULY signal is then pulled low by R40, being limited to $-0.6V$ by the (forward biased) VR6.

POWER SUPPLIES (BLOCK K)

This circuitry filters the supplies used on this assembly.

LOGIC INVERTER/TRANSLATOR (BLOCK L)

The logic inverter/translator inverts the HLEY (High=Lock Enable, YO) signal from the A59 digital interface assembly through the A50 YO loop interconnect assembly. The circuit has two outputs:

1. LLEY (low=lock enable, YO) is a 0 to $-5V$ signal that controls the sample and hold, block H. ($-5V$ = sample, $0V$ = hold). LLEY also disables the YO loop when in the hold mode (during YO sweeps greater than 5 MHz). It does this by pulling the second input of IF limiter U10A to $0V$ (ECL high) (in block B), causing U10A's output to go ECL low ($-1.8V$). This disables the sampler IF input to the phase frequency detector, block D, and causes the output of loop integrator U3 to go to its $-6.9V$ limit. This prevents the YO phase detector from responding to the sweeping YO signal that would produce beat notes as the YO tunes through M/N comb teeth. These beat notes, present at the input of U4, could feed through to cause low-level sidebands on the YO output frequency.
2. The output of the voltage translator (R48-R50) has a range of $+6.7V$ to $0V$. This signal controls FET Q2 in the FM coil driver, block I. Q2 acts as a switch which is on when the gate is at $0V$ and off at $+6.7V$. Q2 is turned off whenever the sample and hold circuit (block H) is in the hold mode, shutting OFF signals through U1 to the FM coil.

A49 YO Loop Phase Detector Troubleshooting

YO UNLOCK

NOTE: When troubleshooting the A49 YO loop phase detector, place the YO Loop in its service position and remove the cover. Leave the YO TUNE and FM COIL cables connected and leave all assemblies involved with the YO Loop in place so that the loop remains closed.

The YO UNLOCK is generated by the HULY (high = unlocked YO) line going high. This is accompanied by the green LED on the A50 YO loop interconnect assembly turning off. This condition is indicated by the Unlocked detector whenever the YO TUNE voltage at A49J2 goes outside the $\pm 6.0V$ range.

Measure YO TUNE using a 3-way connector at A49J2 (to keep the YO loop closed). If it is not outside the $\pm 6.0V$ range, troubleshoot the unlocked detector, block J.

LIMITERS (BLOCK B and BLOCK C)

To verify the operation of the Limiters, Blocks B and C:

1. Use a 100 MHz oscilloscope with a 10:1 probe to measure the input at A49J3 and A49J4 and the outputs of the limiters at TP4 and TP5. The signals at TP4 and TP5 should be square waves at ECL voltage levels (-1.8 to $-0.9V$).

For a signal to exist at TP5, HLEY must be high and the logic inverter/translator circuitry must be functioning properly. This provides $-5V$ to pin 5 of U10A, which enables the second IF Limiter.

PHASE/FREQUENCY DETECTOR (BLOCK D)

To verify the operation of the Phase/Frequency Detector:

1. Make measurements with an oscilloscope at the two inputs, TP4 and TP5 (see the previous paragraph), and the two outputs, TP2 and TP3. The correct output waveforms are described in the circuit theory section for the Phase/Frequency Detector, block D.
2. Use a 10:1 test probe with a short ground clip. If the grounding is not good, there will be ringing on the signal edges. Also refer to the Open Loop Test, below.

Open Loop Test

The following is an open-loop test that can be used to troubleshoot the A49 YO loop phase detector.

1. Set the instrument to CW mode.
2. Disconnect the cables at A49J1 and A49J2, and measure the YO TUNE voltage at A49J2. The voltage will be either $-6.9V$ or $+6.9V$.

3. Switch the sampler IF and the 20-30 MHz input cables (A49J3 and A49J4). This should reverse the polarity at YO TUNE.

SAMPLE AND HOLD (BLOCK H)

With HLEY (high lock enable YIG oscillator) high, and LLEY at $-5V$ (CW or Manual mode), the output of the sample and Hold (block H) should track the input. Verify that HLEY is high and LLEY is at $-5V$, then measure the input and output of U6; they should be identical.

FM COIL DRIVER (BLOCK I)

If the FM Coil Driver (block I) is malfunctioning, the YO Loop will phase lock, but the residual FM on the YO output will be far greater than the typical specification of 60 Hz. The DC output of the operational amplifier should be 0V.

LOGIC INVERTER/TRANSLATOR (BLOCK L)

To test this circuit, TP5 (HLEY) on the A50 YO loop interconnect assembly can be used to force a logic condition to occur:

1. Connect HLEY to $+5V$ and then to ground, verify that the outputs are within the given limits. LLEY can be measured at U6 pin 14 or U10 pin 5.

HLEY	LLEY
$+5V$	$-5V$
0V	0V

A49 YO Loop Phase Detector Component-Level Troubleshooting

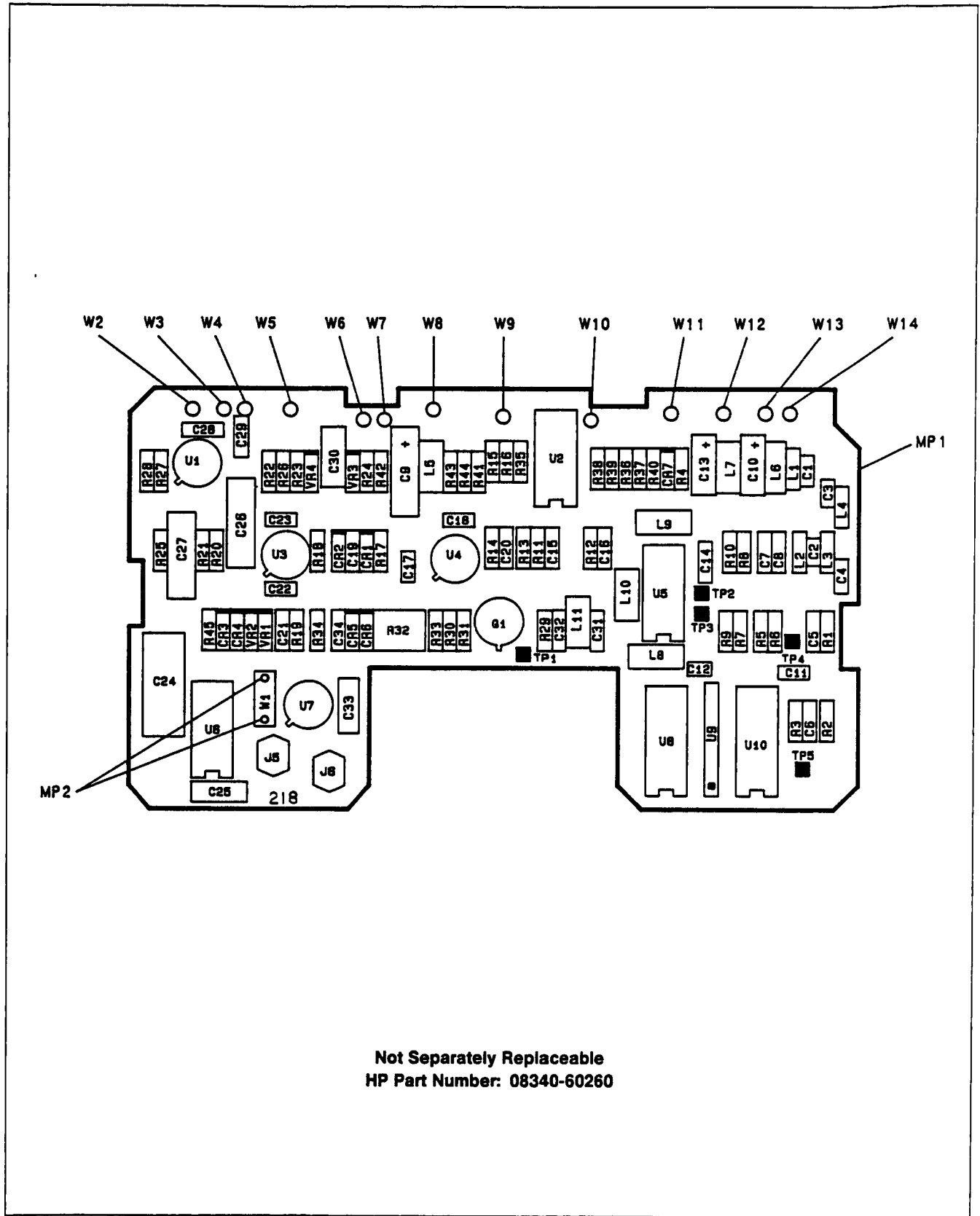

Not Separately Replaceable
 HP Part Number: 08340-60260

Figure A49-1. A49 YO Loop Phase Detector Component Location Diagram

A49 YO Loop Phase Detector Component-Level Troubleshooting

Table A49-1. A49 YO Loop Phase Detector Replaceable Parts

Reference Designation	HP Part Number	C D	Qty	Description	Mfr Code	Mfr Part Number
A49			1	YO LOOP PHASE DETECTOR, NOT SEPERATELY REPLACEABLE, ORDER 08340-80260 CD3 (INCLUDES A48, A49, AND HOUSING)		
A49C1	0160-4805	1	2	CAPACITOR-FXD 47PF ±5% 100VDC CER 0±30	28480	0160-4805
A49C2	0160-4805	1		CAPACITOR-FXD 47PF ±5% 100VDC CER 0±30	28480	0160-4805
A49C3	0160-4526	3	1	CAPACITOR-FXD 42PF ±5% 200VDC CER 0±30	28480	0160-4526
A49C4	0160-4767	4	1	CAPACITOR-FXD 20PF ±5% 200VDC CER 0±30	28480	0160-4767
A49C5	0160-4918	7	2	CAPACITOR-FXD .022UF ±10% 50VDC CER	28480	0160-4918
A49C6	0160-4832	4	2	CAPACITOR-FXD 01UF ±10% 100VDC CER	28480	0160-4832
A49C7	0160-4918	7		CAPACITOR-FXD 022UF ±10% 50VDC CER	28480	0160-4918
A49C8	0160-4832	4		CAPACITOR-FXD 01UF ±10% 100VDC CER	28480	0160-4832
A49C9	0180-0116	1	1	CAPACITOR-FXD 6.8UF ±10% 35VDC TA	56289	150D685X9035B2
A49C10	0160-0197	8	2	CAPACITOR-FXD 2.2UF ±10% 20VDC TA	56289	150D225X9020A2
A49C11	0160-0575	4	7	CAPACITOR-FXD 047UF ±20% 50VDC CER	28480	0160-0575
A49C12	0160-0575	4		CAPACITOR-FXD 047UF ±20% 50VDC CER	28480	0160-0575
A49C13	0180-0197	8		CAPACITOR-FXD 2.2UF ±10% 20VDC TA	56289	150D225X9020A2
A49C14	0160-0575	4		CAPACITOR-FXD 047UF ±20% 50VDC CER	28480	0160-0575
A49C15	0160-0571	0	2	CAPACITOR-FXD 470PF ±20% 100VDC CER	28480	0160-0571
A49C16	0160-0571	0		CAPACITOR-FXD 470PF ±20% 100VDC CER	28480	0160-0571
A49C17	0160-0575	4		CAPACITOR-FXD 047UF ±20% 50VDC CER	28480	0160-0575
A49C18	0160-0575	4		CAPACITOR-FXD 047UF ±20% 50VDC CER	28480	0160-0575
A49C19	0160-3879	7	2	CAPACITOR-FXD 01UF ±20% 100VDC CER	28480	0160-3879
A49C20	0160-3879	7		CAPACITOR-FXD 01UF ±20% 100VDC CER	28480	0160-3879
A49C21	0160-4535	4	4	CAPACITOR-FXD 1UF ±10% 50VDC CER	28480	0160-4535
A49C22	0160-0575	4		CAPACITOR-FXD 047UF ±20% 50VDC CER	28480	0160-0575
A49C23	0160-0575	4		CAPACITOR-FXD 047UF ±20% 50VDC CER	28480	0160-0575
A49C24	0160-3405	5	1	CAPACITOR-FXD 2UF ±10% 50VDC MET-POLYIC	28480	0160-3405
A49C25				NOT ASSIGNED		
A49C26	0160-4535	4		CAPACITOR-FXD 1UF ±10% 50VDC CER	28480	0160-4535
A49C27	0160-3402	2	1	CAPACITOR-FXD 1UF ±5% 50VDC MET-POLYIC	28480	0160-3402
A49C28	0160-4535	4		CAPACITOR-FXD 1UF ±10% 50VDC CER	28480	0160-4535
A49C29	0160-4535	4		CAPACITOR-FXD 1UF ±10% 50VDC CER	28480	0160-4535
A49C30	0160-0164	7	1	CAPACITOR-FXD 039UF ±10% 200VDC POLYE	28480	0160-0164
A49C31	0160-4801	7	1	CAPACITOR-FXD 100PF ±5% 100VDC CER	28480	0160-4801
A49C32	0160-4807	3	1	CAPACITOR-FXD 33PF ±5% 100VDC CER 0±30	28480	0160-4807
A49C33	0160-5098	6	1	CAPACITOR-FXD 22UF ±10% 50VDC CER	16299	CAC05K7R224J050A
A49C34	0160-4835	7	1	CAPACITOR-FXD 1UF ±10% 50VDC CER	28480	0160-4835
A49C35				NOT ASSIGNED		
A49CR1	1901-0539	3	3	DIODE-SM SIG SCHOTTKY	28480	1901-0539
A49CR2	1901-0539	3		DIODE-SM SIG SCHOTTKY	28480	1901-0539
A49CR3	1901-0539	3		DIODE-SM SIG SCHOTTKY	28480	1901-0539
A49J1-4				NOT ASSIGNED		
A49J5	1250-1889	7	2	CONNECTOR-RF SMB M PC 50-OHM	28480	1250-1889
A49J6	1250-1889	7		CONNECTOR-RF SMB M PC 50-OHM	28480	1250-1889
A49L1	9100-0368	6	2	INDUCTOR RF-CH-MLD 330NH 10% 105DX 26LG	28480	9100-0368
A49L2	9100-2254	3	2	INDUCTOR RF-CH-MLD 390NH 10% 105DX 26LG	28480	9100-2254
A49L3	9100-2254	3		INDUCTOR RF-CH-MLD 390NH 10% 105DX 26LG	28480	9100-2254
A49L4	9100-0368	6		INDUCTOR RF-CH-MLD 330NH 10% 105DX 26LG	28480	9100-0368
A49L5	9100-1641	0	2	INDUCTOR RF-CH-MLD 240UH 5% 166DX 385LG	28480	9100-1641
A49L6	9100-3912	2	1	INDUCTOR RF-CH-MLD 15UH 5% 166DX 385LG	28480	9100-3912
A49L7	9100-1641	0		INDUCTOR RF-CH-MLD 240UH 5% 166DX 385LG	28480	9100-1641
A49L8	9140-0398	6	2	INDUCTOR RF-CH-MLD 12UH 5% 166DX 385LG	28480	9140-0398
A49L9	9140-0398	6		INDUCTOR RF-CH-MLD 12UH 5% 166DX 385LG	28480	9140-0398
A49L10	9100-3313	7	2	INDUCTOR RF-CH-MLD 22UH 5% 166DX 385LG	28480	9100-3313
A49L11	9100-3313	7		INDUCTOR RF-CH-MLD 22UH 5% 166DX 385LG	28480	9100-3313
A49Q1	1854-0295	7	1	TRANSISTOR-DUAL NPN PD=400MW	28480	1854-0295
A49Q2	1855-0278	8	1	TRANSISTOR J-FET 2N5116 P-CHAN D-MODE	17856	2N5116
A49R1	0757-0401	0	6	RESISTOR 100 1% 125W F TC=0±100	24546	C4-1/8-T0-101-F
A49R2	0757-0401	0		RESISTOR 100 1% 125W F TC=0±100	24546	C4-1/8-T0-101-F
A49R3	0698-3440	7	4	RESISTOR 196 1% 125W F TC=0±100	24546	C4-1/8-T0-196R-F
A49R4	0757-0401	0		RESISTOR 100 1% 125W F TC=0±100	24546	C4-1/8-T0-101-F
A49R5	0757-0401	0		RESISTOR 100 1% 125W F TC=0±100	24546	C4-1/8-T0-101-F
A49R6	0698-3440	7		RESISTOR 196 1% 125W F TC=0±100	24546	C4-1/8-T0-196R-F
A49R7	0698-3132	4	2	RESISTOR 261 1% 125W F TC=0±100	24546	C4-1/8-T0-2610-F
A49R8	0698-3132	4		RESISTOR 261 1% 125W F TC=0±100	24546	C4-1/8-T0-2610-F
A49R9	0698-3440	7		RESISTOR 196 1% 125W F TC=0±100	24546	C4-1/8-T0-196R-F
A49R10	0698-3440	7		RESISTOR 196 1% 125W F TC=0±100	24546	C4-1/8-T0-196R-F

A49 YO Loop Phase Detector Component-Level Troubleshooting

Table A49-1. A49 YO Loop Phase Detector Replaceable Parts

Reference Designation	HP Part Number	C	D	Qty	Description	Mfr Code	Mfr Part Number
A49R11	0757-0418	9		2	RESISTOR 619 1% .125W F TC=0±100	24546	C4-1/8-T0-619R-F
A49R12	0757-0418	9			RESISTOR 619 1% .125W F TC=0±100	24546	C4-1/8-T0-619R-F
A49R13	0698-3154	0		3	RESISTOR 4 22K 1% .125W F TC=0±100	24546	C4-1/8-T0-4221-F
A49R14	0757-0470	3		1	RESISTOR 162K 1% .125W F TC=0±100	24546	C4-1/8-T0-1623-F
A49R15	0698-0083	8		2	RESISTOR 1.96K 1% .125W F TC=0±100	24546	C4-1/8-T0-1961-F
A49R16	0698-0083	8			RESISTOR 1.96K 1% .125W F TC=0±100	24546	C4-1/8-T0-1961-F
A49R17	0698-3154	0			RESISTOR 4 22K 1% .125W F TC=0±100	24546	C4-1/8-T0-4221-F
A49R18	0757-0274	5		1	RESISTOR 1.21K 1% .125W F TC=0±100	24546	C4-1/8-T0-1211-F
A49R19	0698-3447	4		1	RESISTOR 422 1% .125W F TC=0±100	24546	C4-1/8-T0-422R-F
A49R20	0757-0428	1		2	RESISTOR 1.62K 1% .125W F TC=0±100	24546	C4-1/8-T0-1621-F
A49R21	0757-0428	1			RESISTOR 1.62K 1% .125W F TC=0±100	24546	C4-1/8-T0-1621-F
A49R22	0757-0442	9		4	RESISTOR 10K 1% .125W F TC=0±100	24546	C4-1/8-T0-1002-F
A49R23	0757-0442	9			RESISTOR 10K 1% .125W F TC=0±100	24546	C4-1/8-T0-1002-F
A49R24	0757-0424	7		1	RESISTOR 1.1K 1% .125W F TC=0±100	24546	C4-1/8-T0-1101-F
A49R25	0698-3429	2		2	RESISTOR 19 6 1% .125W F TC=0±100	03888	PME55-1/8-T0-19R6-F
A49R26	0698-3429	2			RESISTOR 19 6 1% .125W F TC=0±100	03888	PME55-1/8-T0-19R6-F
A49R27	0698-3444	1		2	RESISTOR 316 1% .125W F TC=0±100	24546	C4-1/8-T0-316R-F
A49R28					NOT ASSIGNED		
A49R29	0757-0418	7		1	RESISTOR 511 1% .125W F TC=0±100	24546	C4-1/8-T0-511R-F
A49R30	0698-3444	1			RESISTOR 316 1% .125W F TC=0±100	24546	C4-1/8-T0-316R-F
A49R31	0757-0401	0			RESISTOR 316 1% .125W F TC=0±100	24546	C4-1/8-T0-101-F
A49R32	2100-0554	5		1	RESISTOR-TRMR 500 10% C TOP-ADJ 1-TRN	28480	2100-0554
A49R33	0757-0438	3		2	RESISTOR 5 11K 1% .125W F TC=0±100	24546	C4-1/8-T0-5111-F
A49R34	0683-4755	8		1	RESISTOR 4.7M 5% .25W FC TC=-900/+1100	01121	CB4755
A49R35	0757-0288	1		1	RESISTOR 9.09K 1% .125W F TC=0±100	19701	MF4C1/8-T0-9091-F
A49R36	0757-0290	5		2	RESISTOR 6.19K 1% .125W F TC=0±100	19701	MF4C1/8-T0-6191-F
A49R37	0698-3154	0			RESISTOR 4 22K 1% .125W F TC=0±100	24546	C4-1/8-T0-4221-F
A49R38	0698-3156	2		2	RESISTOR 14.7K 1% .125W F TC=0±100	24546	C4-1/8-T0-1472-F
A49R39	0757-0290	5			RESISTOR 6.19K 1% .125W F TC=0±100	19701	MF4C1/8-T0-6191-F
A49R40	0698-3155	1		1	RESISTOR 4.64K 1% .125W F TC=0±100	24546	C4-1/8-T0-4641-F
A49R41	0757-0401	0			RESISTOR 100 1% .125W F TC=0±100	24546	C4-1/8-T0-101-F
A49R42	0757-0346	2		1	RESISTOR 10 1% .125W F TC=0±100	24546	C4-1/8-T0-10R0-F
A49R43	0698-3136	8		1	RESISTOR 17.8K 1% .125W F TC=0±100	24546	C4-1/8-T0-1782-F
A49R44	0757-1094	9		1	RESISTOR 1.47K 1% .125W F TC=0±100	24546	C4-1/8-T0-1471-F
A49R45	0698-3160	8		1	RESISTOR 31.6K 1% .125W F TC=0±100	24546	C4-1/8-T0-3162-F
A49R46	0757-0442	9			RESISTOR 10K 1% .125W F TC=0±100	24546	C4-1/8-T0-1002-F
A49R47	0757-0466	7		1	RESISTOR 110K 1% .125W F TC=0±100	24546	C4-1/8-T0-1103-F
A49R48	0698-3156	2			RESISTOR 14.7K 1% .125W F TC=0±100	24546	C4-1/8-T0-1472-F
A49R49	0757-0442	9			RESISTOR 10K 1% .125W F TC=0±100	24546	C4-1/8-T0-1002-F
A49R50	0698-3157	3		1	RESISTOR 19 6K 1% .125W F TC=0±100	24546	C4-1/8-T0-1962-F
A49R51					NOT ASSIGNED		
A49R52	0757-0438	3			RESISTOR 5.11K 1% .125W F TC=0±100	24546	C4-1/8-T0-5111-F
A49TP1	0360-0535	0		5	TERMINAL TEST POINT PCB	00000	ORDER BY DESCRIPTION
A49TP2	0360-0535	0			TERMINAL TEST POINT PCB	00000	ORDER BY DESCRIPTION
A49TP3	0360-0535	0			TERMINAL TEST POINT PCB	00000	ORDER BY DESCRIPTION
A49TP4	0360-0535	0			TERMINAL TEST POINT PCB	00000	ORDER BY DESCRIPTION
A49TP5	0360-0535	0			TERMINAL TEST POINT PCB	00000	ORDER BY DESCRIPTION
A49U1	1826-0932	0		2	IC OP AMP PRCN 8-DIP-C PKG	06665	OP-27FZ
A49U2	1826-0759	9		1	IC COMPARATOR GP QUAD 14-DIP-C PKG	04713	LM339J
A49U3	1826-0932	0			IC OP AMP PRCN 8-DIP-C PKG	06665	OP-27FZ
A49U4	1826-0987	5		1	IC OP AMP PRCN 8-DIP-C PKG	28480	1826-0987
A49U5	1820-1344	8		1	IC PL LOOP 14-DIP-C PKG	04713	MC12040L
A49U6	1826-1145	9		1	SAMPLE AND HOLD 14-CERDIP	28480	1826-1145
A49U7	1826-0026	3		1	IC COMPARATOR PRCN TO-99 PKG	01295	LM311L
A49U8	1820-0817	8		1	IC FF ECL D-M/S DUAL	04713	MC10131P
A49U9	1810-0204	6		1	NETWORK-RES 8-SIP1 0K OHM X 7	01121	208A102
A49U10	1820-0802	1		1	IC GATE ECL NOR QUAD 2-INP	04713	MC10102P
A49VR1	1902-0049	2		2	DIODE-ZNR 6.19V 5% DO-35 PD= 4W	28480	1902-0049
A49VR2	1902-0049	2			DIODE-ZNR 6.19V 5% DO-35 PD= 4W	28480	1902-0049
A49VR3	1902-3104	8		2	DIODE-ZNR 5.62V 5% DO-35 PD= 4W	28480	1902-3104
A49VR4	1902-3104	6			DIODE-ZNR 5.62V 5% DO-35 PD= 4W	28480	1902-3104
A49VR5	1902-3036	3		1	DIODE-ZNR 3.16V 5% DO-7 PD= 4W TC=-.064%	28480	1902-3036
A49VR6	1902-3082	9		1	DIODE-ZNR 4.64V 5% DO-35 PD= 4W	28480	1902-3082
A49W1	1258-0124	7		1	PIN-PROGRAMING DUMPER 30 CONTACT	91506	8136-475G1
A49W2	8151-0014	5		13	WIRE 24AWG 1X24	28480	8151-0014
A49W3	8151-0014	5			WIRE 24AWG 1X24	28480	8151-0014
A49W4	8151-0014	5			WIRE 24AWG 1X24	28480	8151-0014
A49W5	8151-0014	5			WIRE 24AWG 1X24	28480	8151-0014

A49 YO Loop Phase Detector Component-Level Troubleshooting

Table A49-1. A49 YO Loop Phase Detector Replaceable Parts

Reference Designation	HP Part Number	C D	Qty	Description	Mfr Code	Mfr Part Number
A49W6	8151-0014	5		WIRE 24AWG 1X24	28480	8151-0014
A49W7	8151-0014	5		WIRE 24AWG 1X24	28480	8151-0014
A49W8	8151-0014	5		WIRE 24AWG 1X24	28480	8151-0014
A49W9	8151-0014	5		WIRE 24AWG 1X24	28480	8151-0014
A49W10	8151-0014	5		WIRE 24AWG 1X24	28480	8151-0014
A49W11	8151-0014	5		WIRE 24AWG 1X24	28480	8151-0014
A49W12	8151-0014	5		WIRE 24AWG 1X24	28480	8151-0014
A49W13	8151-0014	5		WIRE 24AWG 1X24	28480	8151-0014
A49W14	8151-0014	5		WIRE 24AWG 1X24	28480	8151-0014
A49X1	1251-4932	9	2	CONNECTOR-SGL CONT SKT 021-IN-BSC-SZ	91506	LSG-1AG14-1

A50 YO Loop Interconnect Circuit Description

ASSEMBLY PURPOSE

The A50 YO loop interconnect assembly distributes power and signals to the A48 YO sampler assembly, the A49 YO phase detector, and the A44A1 YO bias assembly. It also contains the following signals, and each is provided with a test point.

TP2 LOMD low = FM overmodulation is occurring.

TP4 HFIL high = The YIG Oscillator CW filter is engaged.

TP5 HLEY high = The YIG Oscillator loop phase-lock is enabled.

TP7 HULY high = The YIG Oscillator loop is not phase-locked.

The test points serve two purposes:

- Each test point can be used to monitor the state of the digital signal (The level will be somewhat less than the actual signal level due to the resistors on each side of the test points).
- The test point can also be used to force a logic condition to occur by connecting it to +5V or ground.

There are test points provided on the YO loop interconnect assembly for each supply voltage and for the YO coil voltage.

The A50 YO loop interconnect assembly also isolates and separately filters supplies going to different portions of the YO loop assembly.

A50 YO Loop Interconnect Component-Level Troubleshooting

Table A50-1. A62J2 to A50W1P1 Pin I/O

Pin	Mnemonic	A50W1P2	Levels
1 2	-5.2V GND	PIN 1 PIN 2	-5.2V 0V
3 4	HLEY +5.2V	PIN 3 PIN 4	TTL (HIGH TRUE) +5.2V
5 6	HFILYO YO COIL +	PIN 5 PIN 6	TTL (HIGH TRUE) -40V TO -20V
7 8	LOMD YO COIL -/-40V	PIN 7 PIN 8	TTL (LOW TRUE) -40V
9 10	+20V -10V	PIN 9 PIN 10	+20V -10V
11 12	-10V +20V	PIN 11 PIN 12	-10V +20V
13 14	YO COIL -/-40V	PIN 13	-40V
15 16	YO COIL + HULY	PIN 15 PIN 16	-14V TO -20V TTL (HIGH TRUE)
17 18	+5.2V	PIN 17	+5.2V
19 20	GND -5.2V	PIN 19 PIN 29	0V -5.2V

Note: Refer to A50 YO Loop Interconnect Schematic Diagram and A62 motherboard wiring list for signal source and destination information.

A50 YO Loop Interconnect Component-Level Troubleshooting

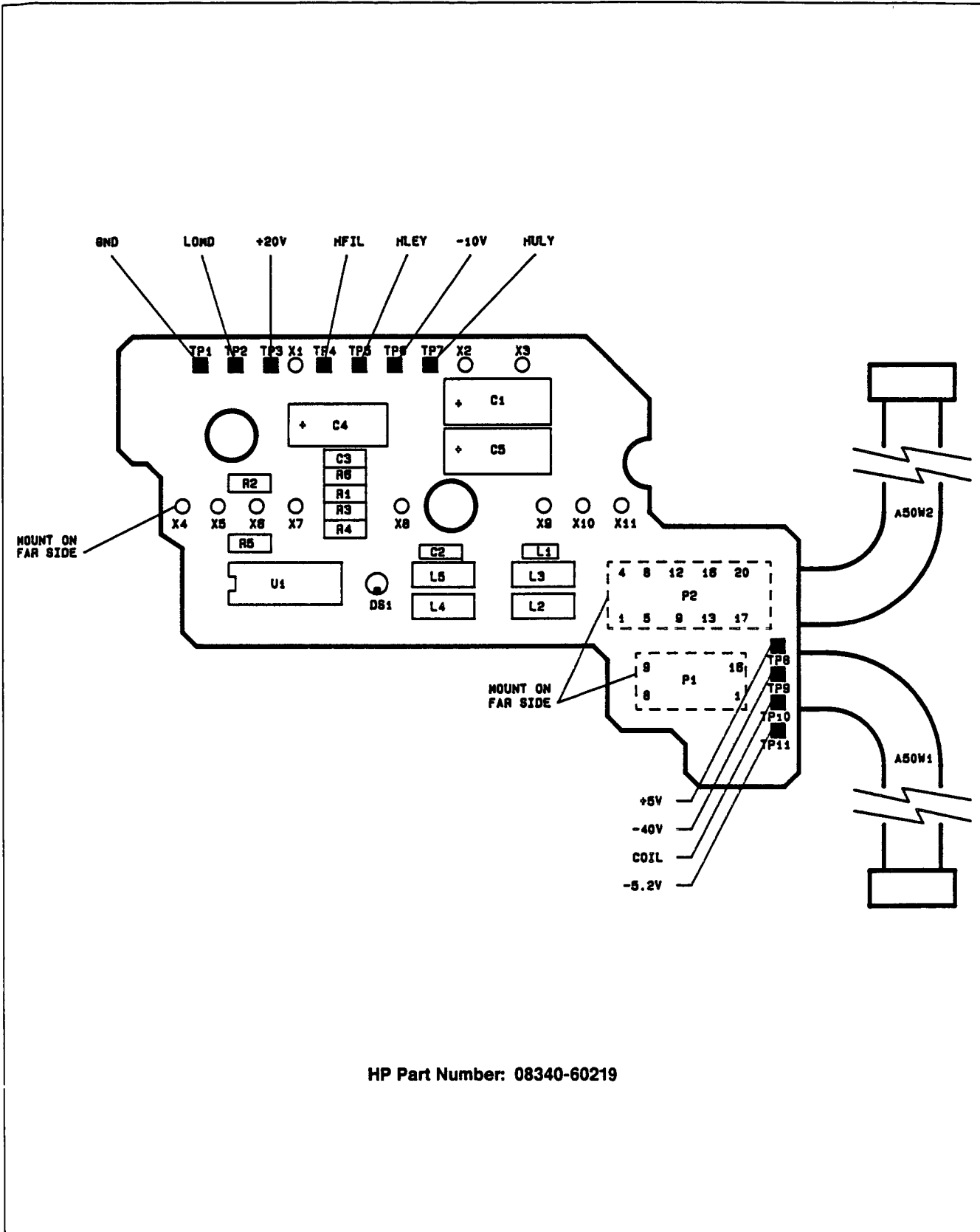

HP Part Number: 08340-60219

Figure A50-1. A50 YO Loop Interconnect Component Location Diagram

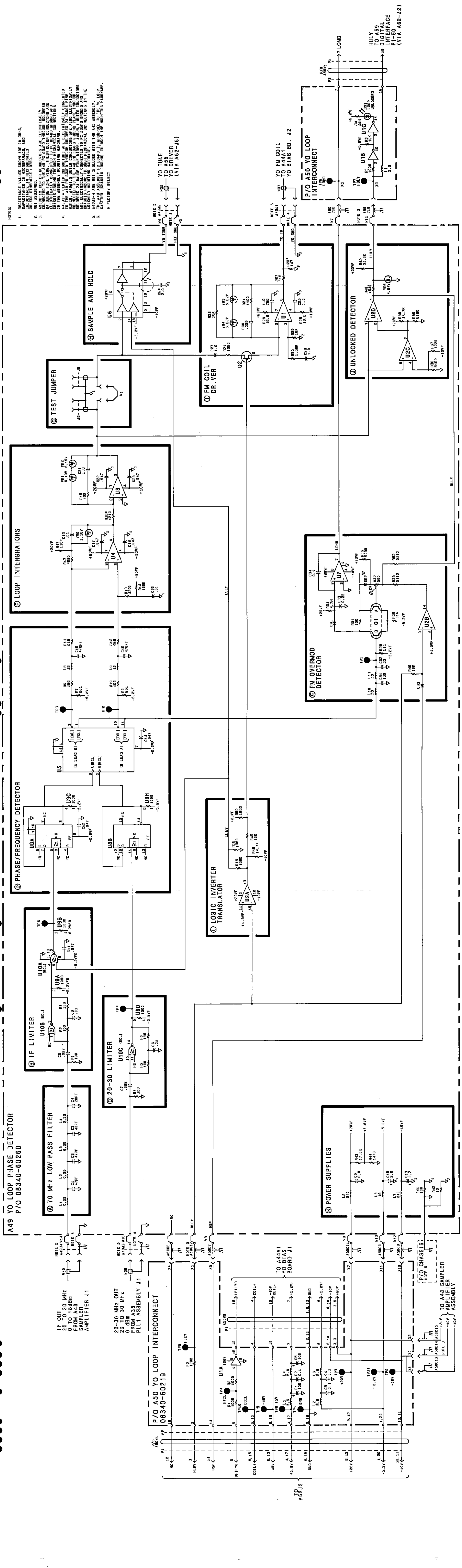

- NOTES:
1. RESISTANCE VALUES GIVEN ARE IN OHMS. INDUCTANCE IN MICROHENRIES, AND CAPACITANCE IN MICROFARADS, AND NOT ABSTRACTED.
 2. ASSOCIATED CENTER CONDUCTORS ARE ELECTRICALLY CONNECTED TO PC BOARD GROUND AND SHOULD BE KEPT AS CLOSE TO BOARD AS POSSIBLE. CENTER CONDUCTORS SHOULD BE KEPT AS CLOSE TO BOARD AS POSSIBLE. CENTER CONDUCTORS SHOULD BE KEPT AS CLOSE TO BOARD AS POSSIBLE.
 3. ASSOCIATED CENTER CONDUCTORS ARE ELECTRICALLY CONNECTED TO PC BOARD GROUND AND SHOULD BE KEPT AS CLOSE TO BOARD AS POSSIBLE. CENTER CONDUCTORS SHOULD BE KEPT AS CLOSE TO BOARD AS POSSIBLE.
 4. ASSOCIATED CENTER CONDUCTORS ARE ELECTRICALLY CONNECTED TO PC BOARD GROUND AND SHOULD BE KEPT AS CLOSE TO BOARD AS POSSIBLE. CENTER CONDUCTORS SHOULD BE KEPT AS CLOSE TO BOARD AS POSSIBLE.
 5. THE A49 ASSEMBLY FC BOARD IS GROUNDED TO THE YO LOOP CHASSIS (CHASSIS GROUND) THROUGH THE MOUNTING HARDWARE.
 6. FACTORY SELECT

YO TUNE TO A49
YO TUNE TO A55
YO DRIVER (VIA A62-16)

NOTE 5
M4 AGUP
NOTE 4
REF CHAS

YO FM COIL TO A44A1
YO BIAS BD. J2

NOTE 5
A48J1
NOTE 4
YO FM
NOTE 3
A48J1
NOTE 4
YO FM

NOTE 3
X11 C10
NOTE 4
X11 C10

NOTE 3
X11 C10
NOTE 4
X11 C10

NOTE 3
X11 C10
NOTE 4
X11 C10

NOTE 3
X11 C10
NOTE 4
X11 C10

NOTE 3
X11 C10
NOTE 4
X11 C10

NOTE 3
X11 C10
NOTE 4
X11 C10

NOTE 3
X11 C10
NOTE 4
X11 C10

Figure A50-2. A49 YO Loop Phase Detector and A50 YO LOOP Interconnect Schematic Diagram A50-5/A50-6 Sweep Generator/YO Loop

A50 YO Loop Interconnect Component-Level Troubleshooting

Table A50-2. A50 YO Loop Interconnect Replaceable Parts

Reference Designation	HP Part Number	C D	Qty	Description	Mfr Code	Mfr Part Number
A50	08340-60219	2	1	YO LOOP INTERCONNECT	28480	08340-60219
A50C1	0180-2614	8	3	CAPACITOR-FXD 100UF ± 10% 30VDC TA	56289	150D107X9030S2
A50C2	0160-4835	7	2	CAPACITOR-FXD .1UF ± 10% 50VDC CER	28480	0160-4835
A50C3	0160-4835	7		CAPACITOR-FXD .1UF ± 10% 50VDC CER	28480	0160-4835
A50C4	0180-2614	8		CAPACITOR-FXD 100UF ± 10% 30VDC TA	56289	150D107X9030S2
A50C5	0180-2614	8		CAPACITOR-FXD 100UF ± 10% 30VDC TA	56289	150D107X9030S2
A50C6-16	0160-3036	8	11	CAPACITOR-FDTHRU 5000PF +80 -20% 200V	28480	0160-3036
A50DS1	1990-0485	5	1	LED-LAMP LUM-INT=800UCD IF=30MA-MAX	28480	5082-4984
A50L1	9100-2262	3	1	INDUCTOR RF-CH-MLD 3.9UH 10% 105DX.26LG	28480	9100-2262
A50L2	9100-1618	1	4	INDUCTOR RF-CH-MLD 5.6UH 10%	28480	9100-1618
A50L3	9100-1618	1		INDUCTOR RF-CH-MLD 5.6UH 10%	28480	9100-1618
A50L4	9100-1618	1		INDUCTOR RF-CH-MLD 5.6UH 10%	28480	9100-1618
A50L5	9100-1618	1		INDUCTOR RF-CH-MLD 5.6UH 10%	28480	9100-1618
A50R1	0757-0280	3	4	RESISTOR 1K 1% .125W F TC=0 ± 100	24546	C4-1/8-T0-1001-F
A50R2	0757-0280	3		RESISTOR 1K 1% .125W F TC=0 ± 100	24546	C4-1/8-T0-1001-F
A50R3	0757-0442	9	1	RESISTOR 10K 1% .125W F TC=0 ± 100	24546	C4-1/8-T0-1002-F
A50R4	0757-0416	7	1	RESISTOR 511 1% .125W F TC=0 ± 100	24546	C4-1/8-T0-511R-F
A50R5	0757-0280	3		RESISTOR 1K 1% .125W F TC=0 ± 100	24546	C4-1/8-T0-1001-F
A50R6	0757-0280	3		RESISTOR 1K 1% .125W F TC=0 ± 100	24546	C4-1/8-T0-1001-F
A50TP1-11	0360-2050	8	11	TEST POINT	28480	0360-2050
A50U1	1858-0047	5	1	TRANSISTOR ARRAY 16-PIN PLSTC DIP	13606	ULN-2003A
A50W1	8120-3120	5	1	CABLE	28480	8120-3120
A50W2	08340-60209	0	1	CABLE RBN 16 PIN (INCLUDES W2P1 P2)	28480	08340-60209
A50X1-11	1251-2313	6	11	CONNECTOR-SGL CONT SKT .04-IN-BSC-SZ RND	28480	1251-2313

A54 YO Pretune/Delay Compensation Circuit Description

ASSEMBLY PURPOSE

The A54 YO pretune/delay compensation assembly performs three major functions:

- Provides a DC voltage (Pretune) to the A55 YO driver that is proportional to the frequency to which the YO is phase-locked.
- Generates the kick pulses necessary at a YO retrace to preset the magnetic domains of the YO to eliminate the affects of magnetic hysteresis. These pulses are of constant amplitude, corresponding to about 2.5 GHz, and are of varying width. The width is a function of the YO start frequency and sweep width of the previous sweep as well as the YO start frequency of the next sweep.
- Provides a voltage (VCOMP) to the A55 YO driver that is used to compensate for the YO frequency delay.

PRETUNE REGISTER (BLOCK A)

U11 and U13 latch data bits 1-12 from the 16 bit instrument data bus to set the Pretune voltage. The strobe that activates the latch is WPDAC (write pretune DAC). This strobe is channel 3, sub-channel 2 from the processor (3,R2:). U10 and U12 contain pull-up resistors to back bias the output stages of the latches when the outputs are high so that bus noise cannot come through to the DAC.

PRETUNE DAC (BLOCK B)

U6 is a 12-bit bipolar DAC. It takes the 10V reference voltage and the latched data bits to give a DC voltage at TP6. VDAC, given by the formula:

$$VDAC = 2.10 \times (f_{YO} - 2.3)$$

Where F_{YO} is stated in GHz.

Example: $F_{YO} = 3$ GHz (3)

$$VDAC = 2.1 \times (3 - 2.3) = 1.47 \text{ volts}$$

NOTE: The actual measured value of VDAC must be rounded up to three significant figures to match the calculated value.

The sensitivity of this block is +2.100 Volts/GHz.

Note that the latches pick off data bits 1-12, not 0-11. This means that the number sent by the processor and the number that shows up at the input of the DAC differ by a factor of 2.

R14 is adjusted to take out the tolerance of the summing resistors R19 and R20 as well as the gain tolerance of U6 itself. CR4 is a protection diode to insure that U6 pin 9 does not go much below pin 12 (ground). U2 is a high performance operational amplifier chosen for its low offset voltage, good temperature characteristics, and low noise. C15 provides stability compensation for the DAC.

2.3 GHz is the lowest frequency that the YO can be tuned to, and corresponds to a DAC number of zero. The highest frequency that the YO can be tuned to is 7.0 GHz and this corresponds to a DAC number of 4089. Note that this is not all digital ones at the DAC input but a slightly smaller number.

SUMMING AMPLIFIER (BLOCK C)

The summing amplifier combines three signals to give the final Pretune voltage. These signals are:

- VREF, a voltage corresponding to 2.3 GHz (R22-24).
- VDACC, the DAC voltage which is proportional to lock frequency minus 2.3 GHz (R19, R20).
- VSWP, the sweep ramp (R25, R26).

The combined signal is called PRETUNE, TP3, and has a YO sensitivity of -2.5 V/GHz. R22 adjusts for the tolerance of R21, R22, R23, the $+10$ volt reference, and the offset voltage of U4.

A further note about PRETUNE: The 2.3 GHz offset is used so that the greatest resolution can be achieved from the DAC. Pretune is routed to the A28 SYTM driver where it is scaled and used to tune the SYTM.

VOLTAGE REFERENCE (BLOCK D)

The reference voltage for the pretune system is derived from VR1, a low noise, 1%, 5 ppm reference zener diode. The circuit provides a constant bias current of 7.5 mA through the diode. R10 and C11 give extra filtering of diode noise.

Note that C11 has low leakage, low noise, and good temperature stability. The current from the operational amplifier is not sufficient to cover the worst case needs of the circuit, R49 provides the remainder of the current.

SWEEP DISABLE SWITCH (BLOCK E)

FET Q3 is a switch that grounds the junction of R25 and R26 (block C) when LVSX (low voltage sweep disable) is low. This prevents noise from the sweep generator from being added to the PRETUNE voltage when the instrument is in the CW, MANUAL, or narrow sweep modes (YIG oscillator sweep width is ≤ 500 kHz).

LVSX is high when the instrument is in the sweep mode and the sweep width is > 500 kHz (except at phase lock at the beginning of sweep). Any small DC offset at the output of the sweep generator (after it is reset) is added to the PRETUNE voltage while the instrument is acquiring phase-lock. This offset does not effect the sweep accuracy, however, as long as it is not great enough to keep the YO from acquiring phase-lock.

YO DELAY COMPENSATION (BLOCK F)

This circuit compensates for frequency lag or delay in the YO during a sweep due to eddy currents in the magnetic poles.

The YO delay compensation circuit generates a voltage, VCOMP (TP4). This voltage is sent to the A55 YO driver where it is used to speed up the sweep to make the frequency more closely follow the PRETUNE voltage, compensating for the YO frequency delay.

To generate this voltage, the circuit sums a VREF reference voltage (COFF adjustment) and the VSWP voltage ramp (CGN adjustment). The resulting voltage is the analog input to an 8 bit DAC whose digital input, provided by the processor, is related to the sweep rate. The DAC then performs the multiplication, and thus the voltage, called VCOMP, is of the desired form. The strobe for this DAC is 5,R3: (write compensation DAC). C31 is used for stability compensation of the DAC.

In this configuration, U16 outputs a high impedance voltage at pin 21. U14A buffers this output voltage and provides the necessary low output impedance. R35 was chosen to match the 5K Ω internal DAC impedance to ensure unity gain for U14A. CR6 clamps the maximum DAC output at ground.

YO RETRACE KICK PULSE GENERATOR (BLOCK G)

This circuit generates a programmable pulse width via the 8 bit DAC, U15. This low-going pulse is sent to the A55 YO driver where it is converted to a 60 mA current drain from the YO drive current. This temporarily tunes the YO 2.5 GHz lower in frequency, eliminating magnetic hysteresis.

The instrument processor initiates a kick pulse by first writing to the pulse width DAC address, 5,R1: (WYOKW, write YO kick width), a number that corresponds to the desired pulse width. This write loads U15 and resets the pulse circuit through U9. At the appropriate time, the processor sends a trigger 3,R0: (TYOKP, trigger YO kick pulse), which starts the pulse. The circuit then terminates the pulse after the programmed length of time has elapsed.

The write to the pulse width DAC (WYOKW, Write YO Kick Width) initializes the pulse width circuitry as follows. U9 is set. (Note: U9 is an LS74, and the set and reset inputs function as a standard flip-flop.) The Q_O output of U9, pin 8, turns on switch Q4, which zeros the integrator formed by U14B and C29. The write (WYOKW) also programs the DAC, U15, to a voltage between 0 and +10 volts which corresponds to the desired pulse width.

Since the inverting input of U14B is a virtual ground and the reference voltage from U15, pins 13 & 14, is a constant +5 volts, there is a constant current of about 64 microamps into the integrator. Because the capacitor is shorted by Q4 at this point, the output of U14B is zero volts.

When the trigger pulse (TYOKP, trigger YO kick pulse) is received from the processor, U9 is reset, causing U9 pin 8 to go high, turning Q4 off through U7D. The constant current of 64 microamps into the integrator now gives rise to a negative going ramp at the output of U14B with a constant slope of about -291 volts/second. When this ramp reaches a value equal in magnitude, but opposite in polarity, to the voltage at the output of the DAC (U15), then comparator U8 fires and clocks U9. This effectively sets U9, turning off the kick pulse and zeroing the integrator.

The only adjustment in this circuit is R36, that varies the current to the integrator to take out tolerances in the integrating capacitor, C29, and current setting resistor, R37.

The number written to the pulse width DAC address is related to the pulse width by the following formula:

$$\text{Pulse width (in microseconds)} = [(\text{Number})/512] \times 34 \text{ ms}$$

Since the DAC input is driven by bits 1-8 rather than 0-7, the binary number that appears at the input of U15 is the number calculated above, divided by two.

POWER SUPPLIES (BLOCK H)

L1-L5 and C1-C5 form standard low-pass power supply filters.

U1 and U3 are 3-terminal 5 volt and 15 volt regulators. CR1 and CR2 are protection diodes. If the input to either regulator is shorted to ground the discharge currents of C9, C35 and any onboard capacitance is shunted through these protection diodes rather than through the regulators. Reverse current through these regulators destroys them.

Q2 is a voltage follower. C7, R3 and R4 provide noise filtering to the base of the transistor.

R2 provides a back-up connection between reference and chassis grounds so that if the motherboard connection between the grounds is broken, this circuit will continue to operate, although not necessarily within design tolerances.

A54 YO Pretune/Delay Compensation Component-Level Troubleshooting

PRETUNE INCORRECT

In all modes, the sensitivity of the PRETUNE output, TP3, is -2.5 volts/GHz (relative to YO frequency). This is the place to begin troubleshooting.

1. In CW mode, use the front panel knob to set the RF output frequency to different frequencies between 2.3 and 6.99 GHz.

2. Make sure PRETUNE provides its normal -2.5 volts/GHz output.

NOTE: Don't increase the frequency to 7 GHz or the PRETUNE will change to -8.75 V, corresponding to the YIG Oscillator's actual output of 3.5 GHz. This occurs because, in CW mode, the instrument switches into the second harmonic band.

3. If the PRETUNE voltage (TP3) is not correct, then check all inputs to the summing amplifier.

a. Check VSWP. In CW mode VSWP should always be 0V. If it is not 0V, troubleshoot the A58 Sweep Generator.

b. VDAC (TP6) should have a sensitivity of $2.1V \times [f_{YO}-2.3]$.

c. VREF (TP5) should be $+10V \pm 10\%$.

4. BLVSX (TP1) should be $< +0.5$ or an undesired voltage offset will be present on PRETUNE. If VDAC (TP6) is not at the correct voltage, check the digital inputs and the input from VREF. The formula for calculating what the VDAC and digital input should be is given in the theory section for the pretune DAC (in block B).

5. In sweep mode, if the PRETUNE voltage does not ramp, check to see that VSWP, P1-26, is present. VSWP should have an output of $+2$ volts/GHz. Make sure that BLVSX (TP1) is $+15$ V, so that the sweep voltage is summed with the start frequency PRETUNE voltage.

LKICK INCORRECT

If there is no retrace kick pulse:

1. Check LKICK to see that it goes low during the period of the kick. If LKICK is not working correctly, then the YO retrace kick pulse generator (block G) must be checked.

a. The operation of U15 can be verified by writing to its address, 5,R1: (Refer to the Direct I/O Addressing description in the Component-Level Service Introduction). Writing zero to this address should result in zero volts at U15, pin 18. Writing 511 should result in $+10$ volts at U15 pin 18.

VCOMP CHECK

To test U16 (YO Delay Compensation, block F):

1. Set the instrument to sweep from 2.3 GHz to 7.0 GHz with a 10 ms sweep time. VCOMP should be a negative-going ramp with a step at the start. The voltage should go from approximately -0.5 to -2 volts. These voltages vary and depend upon how the COFF and CGN pots have been adjusted. Variations of $\pm 50\%$ are typical. However, as the sweep time is increased to .5 seconds, the step at the start of sweep and the slope of the ramp should decrease smoothly to zero.

VCOMP INCORRECT

1. Check VSWP. VSWP is a $+2$ volts/GHz positive-going ramp which **always begins at 0 volts**. If the YO sweep width is 1 GHz, VSWP will ramp from 0 volts up to $+2$ volts, regardless of the specific start frequency. With the instrument sweeping from 3 GHz to 7 GHz, VSWP should be a positive-going 0V to $+8.0V$ ramp ($+2$ volts/GHz \times 4 GHz sweep).

NOTE: Do not check VSWP with start and stop frequencies that cross band switch points. This is because VSWP resets to zero volts at each bandcrossing.

2. Check VREF for $+10V \pm 10\%$. Check for high-going TTL strobe pulses on the WCDAC input. If all circuit inputs and power supplies are good, suspect U14 or U16.

A54 YO Pretune/Delay Compensation Component-Level Troubleshooting

Table A54-1. A54 YO Pretune/Delay Compensation P1 Pin I/O

Pin	Mnemonic	Levels	Source	Destination
1 19	+20V LKICK	+20V TTL	XA52P1-16, 40 G	*H XA55P1-1
2 20	+5.2V +5.2V	+5.2V +5.2V	XA52P1-17, 18, 41, 42 XA52P1-17, 18, 41, 42	*H *H
3 21	-40V/-40V SENSE (-) YOKICK	-40V TTL (HIGH TRUE)	XA53P1-11,30/XA53P1-23 G	*H/H *
4 22	-10V -10V	-10V -10V	XA53P1-12, 13, 31, 32 XA53P1-12, 13, 31, 32	*H *H
5 23	GND GND	0V 0V	A62 STAR GND A62 STAR GND	*H *H
6 24	WYOKW PRETUNE	TTL (LOW TRUE) -2.5V/GHZ, 0V = 2.3 GHZ	XA59P1-99 C	G *
7 25	RGND RGND	0V 0V	STAR GND POINT STAR GND POINT	*H *H
8 26	-15V VSWP	-15V 0 TO 10V SWEEP	XA56P1-15, 30 XA58P1-97	*H *C F
9 27	LVSX VCOMP	TTL (LOW TRUE) -26 MHZ/VOLT	XA58P1-68 F	E XA55P1-9
10 28	DB1 WCDAC	TTL TTL (LOW TRUE)	XA60P1-76 XA59P1-30	*A G F
11 29	DB3 DB2	TTL TTL	XA60P1-77 XA60P1-21	*A G *A G
12 30	DB5 DB4	TTL TTL	XA60P1-78 XA60P1-22	*A G *A G
13 31	DB7 DB6	TTL TTL	XA60P1-79 XA60P1-23	*A G *A G
14 32	DB9 DB8	TTL TTL	* *	*A F *A F G
15 33	DB11 DB10	TTL TTL	* *	*A F *A F
16 34	DB13 DB12	TTL TTL	XA60P1-82 *	*F *A F
17 35	DB15 DB14	TTL TTL	XA60P1-83 XA60P1-27	*F *F
18 36	TYOKP WPDAC	TTL (LOW TRUE) TTL (LOW TRUE)	XA59P1-100 XA59P1-68	*G A

A circled letter in the source or destination column refers to a function block on this assembly schematic. An asterisk (*) denotes multiple sources or destinations; refer to the A62 motherboard wiring list for a complete listing of signal destinations.

A54 YO Pretune/Delay Compensation Component-Level Troubleshooting

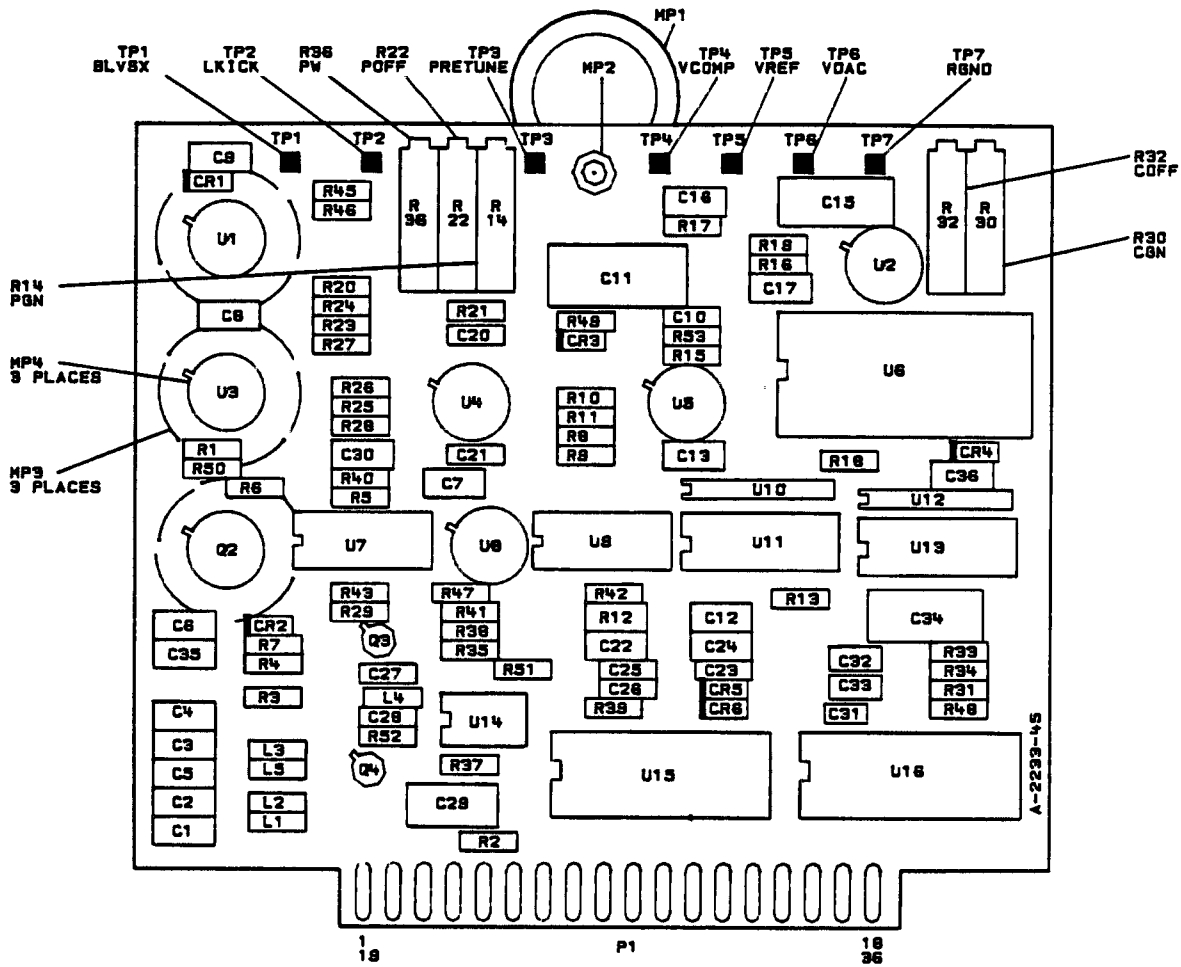

HP Part Number: 08340-60217

Figure A54-1. A54 YO Pretune DAC/Delay Compensation Component Location Diagram

A54 YO PRETUNE/DELAY COMPENSATION
08340-60217

P1-10	(IN)	DB1
P1-20	(IN)	DB2
P1-11	(IN)	DB3
P1-21	(IN)	DB4
P1-31	(IN)	DB5
P1-31	(IN)	DB6
P1-31	(IN)	DB7
P1-31	(IN)	DB8
P1-31	(IN)	DB9
P1-31	(IN)	DB10
P1-31	(IN)	DB11
P1-31	(IN)	DB12
P1-31	(IN)	DB13
P1-31	(IN)	DB14
P1-31	(IN)	DB15
P1-31	(IN)	DB16
P1-31	(IN)	DB17
P1-31	(IN)	DB18
P1-31	(IN)	DB19
P1-31	(IN)	DB20
P1-31	(IN)	DB21
P1-31	(IN)	DB22
P1-31	(IN)	DB23
P1-31	(IN)	DB24
P1-31	(IN)	DB25
P1-31	(IN)	DB26
P1-31	(IN)	DB27
P1-31	(IN)	DB28
P1-31	(IN)	DB29
P1-31	(IN)	DB30

NOTES
1. RESISTANCE VALUES SHOWN ARE IN OHMS, CAPACITANCE IN MICROFARADS, AND INDUCTANCE IN MICROHENRIES UNLESS OTHERWISE NOTED.

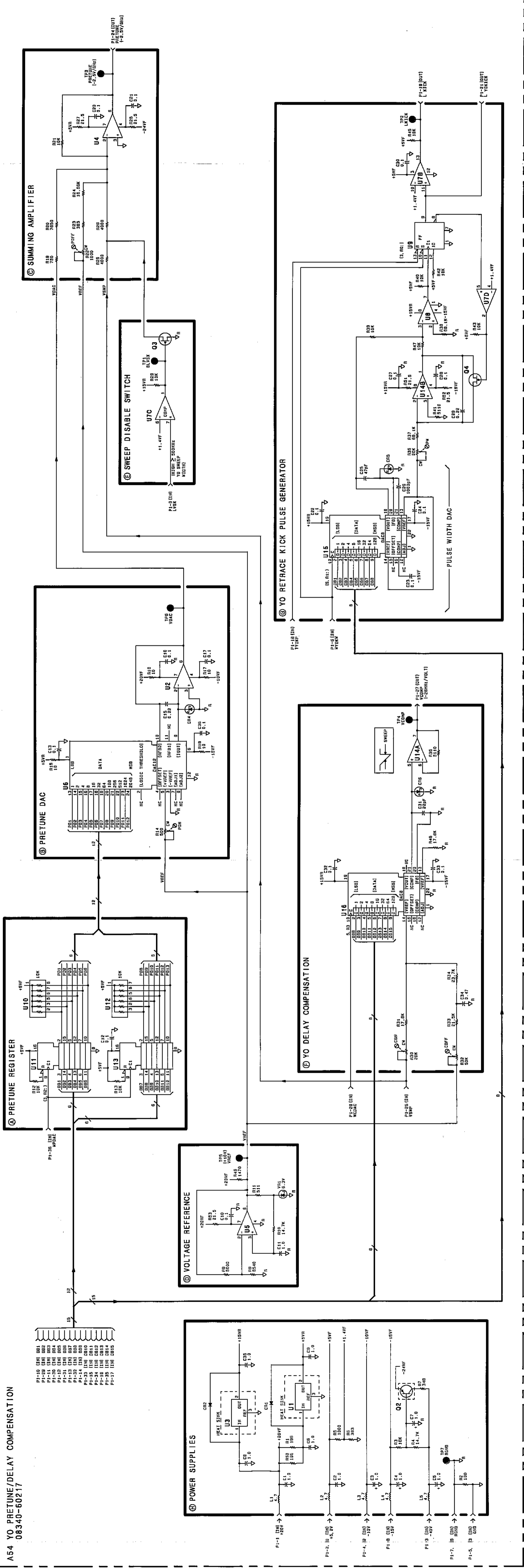

Figure A54-2. A54 YO Pretune/Delay Compensation, Schematic Diagram
A54-9/A54-10
Sweep Generator/YO Loop

A54 YO Pretune/Delay Compensation Component-Level Troubleshooting

Table A54-2. A54 YO Pretune/Delay Compensation Replaceable Parts

Reference Designation	HP Part Number	C D	Qty	Description	Mfr Code	Mfr Part Number
A54	08340-60217	0	1	YO PRETUNE DAC/DELAY COMPENSATION	28480	08340-60217
A54C1	0160-4535	4	9	CAPACITOR-FXD 1UF ±10% 50VDC CER	28480	0160-4535
A54C2	0160-4535	4		CAPACITOR-FXD 1UF ±10% 50VDC CER	28480	0160-4535
A54C3	0160-4535	4		CAPACITOR-FXD 1UF ±10% 50VDC CER	28480	0160-4535
A54C4	0160-4535	4		CAPACITOR-FXD 1UF ±10% 50VDC CER	28480	0160-4535
A54C5	0160-3670	6	1	CAPACITOR-FXD 1UF ±20% 200VDC CER	28480	0160-3670
A54C6	0160-4535	4		CAPACITOR-FXD 1UF ±10% 50VDC CER	28480	0160-4535
A54C7	0160-4535	4		CAPACITOR-FXD 1UF ±10% 50VDC CER	28480	0160-4535
A54C8	0160-4535	4		CAPACITOR-FXD 1UF ±10% 50VDC CER	28480	0160-4535
A54C9	0160-4535	4		CAPACITOR-FXD 1UF ±10% 50VDC CER	28480	0160-4535
A54C10	0160-4835	7	15	CAPACITOR-FXD 1UF ±10% 50VDC CER	28480	0160-4835
A54C11	0160-3402	2	1	CAPACITOR-FXD 1UF ±5% 50VDC MET-POLYC	28480	0160-3402
A54C12	0160-4835	7		CAPACITOR-FXD 1UF ±10% 50VDC CER	28480	0160-4835
A54C13	0160-4835	7		CAPACITOR-FXD 1UF ±10% 50VDC CER	28480	0160-4835
A54C14				NOT ASSIGNED		
A54C15	0160-4261	3	1	CAPACITOR-FXD 22UF ±10% 50VDC	84411	HEW 249
A54C16	0160-4835	7		CAPACITOR-FXD 1UF ±10% 50VDC CER	28480	0160-4835
A54C17	0160-4835	7		CAPACITOR-FXD 1UF ±10% 50VDC CER	28480	0160-4835
A54C18, 19				NOT ASSIGNED		
A54C20	0160-4835	7		CAPACITOR-FXD 1UF ±10% 50VDC CER	28480	0160-4835
A54C21	0160-4835	7		CAPACITOR-FXD 1UF ±10% 50VDC CER	28480	0160-4835
A54C22	0160-4835	7		CAPACITOR-FXD 1UF ±10% 50VDC CER	28480	0160-4835
A54C23	0160-4832	4	1	CAPACITOR-FXD 01UF ±10% 100VDC CER	28480	0160-4832
A54C24	0160-4835	7		CAPACITOR-FXD 1UF ±10% 50VDC CER	28480	0160-4835
A54C25	0160-4805	1	1	CAPACITOR-FXD 47PF ±5% 100VDC CER 0±30	28480	0160-4805
A54C26	0160-4574	1	1	CAPACITOR-FXD 1000PF ±10% 100VDC CER	28480	0160-4574
A54C27	0160-4835	7		CAPACITOR-FXD 1UF ±10% 50VDC CER	28480	0160-4835
A54C28	0160-4835	7		CAPACITOR-FXD 1UF ±10% 50VDC CER	28480	0160-4835
A54C29	0160-5098	6	1	CAPACITOR-FXD 22UF ±10% 50VDC CER	16299	CAC05X7R224J050A
A54C30	0160-4835	7		CAPACITOR-FXD 1UF ±10% 50VDC CER	28480	0160-4835
A54C31	0160-4787	8	1	CAPACITOR-FXD 22PF ±5% 100VDC CER 0±30	28480	0160-4787
A54C32	0160-4835	7		CAPACITOR-FXD 1UF ±10% 50VDC CER	28480	0160-4835
A54C33	0160-4835	7		CAPACITOR-FXD 1UF ±10% 50VDC CER	28480	0160-4835
A54C34	0160-3829	7	1	CAPACITOR-FXD 47UF ±10% 50VDC	28480	0160-3829
A54C35	0160-4535	4		CAPACITOR-FXD 1UF ±10% 50VDC CER	28480	0160-4535
A54C36	0160-4835	7		CAPACITOR-FXD 1UF ±10% 50VDC CER	28480	0160-4835
A54CR1	1901-0033	2	2	DIODE-GEN PRP 180V 200MA DO-7	28480	1901-0033
A54CR2	1901-0033	2		DIODE-GEN PRP 180V 200MA DO-7	28480	1901-0033
A54CR3				NOT ASSIGNED		
A54CR4	1901-0518	8	3	DIODE-SM SIG SCHOTTKY	28480	1901-0518
A54CR5	1901-0518	8		DIODE-SM SIG SCHOTTKY	28480	1901-0518
A54CR6	1901-0518	8		DIODE-SM SIG SCHOTTKY	28480	1901-0518
A54L1	9140-0144	0	5	INDUCTOR RF-CH-MLD 4.7UH 10% 105DX 28LG	28480	9140-0144
A54L2	9140-0144	0		INDUCTOR RF-CH-MLD 4.7UH 10% 105DX 28LG	28480	9140-0144
A54L3	9140-0144	0		INDUCTOR RF-CH-MLD 4.7UH 10% 105DX 28LG	28480	9140-0144
A54L4	9140-0144	0		INDUCTOR RF-CH-MLD 4.7UH 10% 105DX 28LG	28480	9140-0144
A54L5	9140-0144	0		INDUCTOR RF-CH-MLD 4.7UH 10% 105DX 28LG	28480	9140-0144
A54MP1	5040-6848	7	1	EXTRACTOR	28480	5040-6848
A54MP2				NOT ASSIGNED		
A54MP3				NOT ASSIGNED		
A54MP4				NOT ASSIGNED		
A54MP5	1205-0011	0	3	HEAT SINK TO-5/TO-39-CS	28480	1205-0011
A54MP6	1205-0011	0		HEAT SINK TO-5/TO-39-CS	28480	1205-0011
A54MP7	1205-0011	0		HEAT SINK TO-5/TO-39-CS	28480	1205-0011
A54MP8	5000-9043	6	1	PIN:P.C. BOARD EXTRACTOR	28480	5000-9043
A54Q1				NOT ASSIGNED		
A54Q2	1853-0038	4	1	TRANSISTOR PNP SI TO-39 PD-1W FT-100MHZ	28480	1853-0038
A54Q3	1855-0278	8		TRANSISTOR J-FET 2N5116 P-CHAN D-MODE	17856	2N5116
A54Q4	1855-0278	8		TRANSISTOR J-FET 2N5116 P-CHAN D-MODE	17856	2N5116
A54R1	0698-3440	7	2	RESISTOR 196 1% 125W F TC=0±100	24546	C4-1/8-T0-196R-F
A54R2	0757-0401	0	1	RESISTOR 100 1% 125W F TC=0±100	24546	C4-1/8-T0-101-F
A54R3	0757-0442	9	10	RESISTOR 10K 1% 125W F TC=0±100	24546	C4-1/8-T0-1002-F
A54R4	0698-3156	2	2	RESISTOR 14.7K 1% 125W F TC=0±100	24546	C4-1/8-T0-1472-F
A54R5	0757-0280	3	1	RESISTOR 1K 1% 125W F TC=0±100	24546	C4-1/8-T0-1001-F

A54 YO Pretune/Delay Compensation Component-Level Troubleshooting

Table A54-2. A54 YO Pretune/Delay Compensation Replaceable Parts

Reference Designation	HP Part Number	C	D	Qty	Description	Mfr Code	Mfr Part Number
A54R6	0698-3448	3	2		RESISTOR 383 1% .125W F TC=0±100	24546	C4-1/8-T0-383R-F
A54R7	0698-3445	2	1		RESISTOR 348 1% .125W F TC=0±100	24546	C4-1/8-T0-348R-F
A54R8	0699-0059	0	1		RESISTOR 5K 1% 1W F TC=0±5	28480	0699-0059
A54R9	0698-6406	1	1		RESISTOR 8.54K 1% 1W F TC=0+4	28480	0698-6406
A54R10	0698-3158	2			RESISTOR 14.7K 1% .125W F TC=0±100	24546	C4-1/8-T0-1472-F
A54R11	0757-0416	7	1		RESISTOR 511 1% .125W F TC=0±100	24546	C4-1/8-T0-511R-F
A54R12	0757-0442	9			RESISTOR 10K 1% .125W F TC=0±100	24546	C4-1/8-T0-1002-F
A54R13	0757-0442	9			RESISTOR 10K 1% .125W F TC=0±100	24546	C4-1/8-T0-1002-F
A54R14	2100-3123	0	1		RESISTOR-TRMR 500 10% C SIDE-ADJ 17-TRN	02111	43P501
A54R15	0757-0346	2	4		RESISTOR 10 1% .125W F TC=0±100	24546	C4-1/8-T0-10R0-F
A54R16	0757-0346	2			RESISTOR 10 1% .125W F TC=0±100	24546	C4-1/8-T0-10R0-F
A54R17	0757-0346	2			RESISTOR 10 1% .125W F TC=0±100	24546	C4-1/8-T0-10R0-F
A54R18	0757-0346	2			RESISTOR 10 1% .125W F TC=0±100	24546	C4-1/8-T0-10R0-F
A54R19	0757-0420	3	1		RESISTOR 750 1% .125W F TC=0±100	24546	C4-1/8-T0-751-F
A54R20	0699-0797	3	1		RESISTOR 7 65K 1% 1W F TC=0+4	28480	0699-0797
A54R21	0699-0642	7	1		RESISTOR 10K 1% 1W F TC=0±5	28480	0699-0642
A54R22	2100-3154	7	1		RESISTOR-TRMR 1K 10% C SIDE-ADJ 17-TRN	02111	43P102
A54R23	0698-3446	3			RESISTOR 383 1% .125W F TC=0±100	24546	C4-1/8-T0-383R-F
A54R24	0698-8500	0	1		RESISTOR 16 58K 1% 1W F TC=0+4	28480	0698-8500
A54R25	0699-0747	3	2		RESISTOR 4K .05% 1W F TC=0±10	28480	0699-0747
A54R26	0699-0747	3			RESISTOR 4K .05% 1W F TC=0±10	28480	0699-0747
A54R27	0698-3430	5	5		RESISTOR 21 5 1% .125W F TC=0±100	03888	PME55-1/8-T0-21R5-F
A54R28	0698-3430	5			RESISTOR 21 5 1% .125W F TC=0±100	03888	PME55-1/8-T0-21R5-F
A54R29	0757-0442	9			RESISTOR 10K 1% .125W F TC=0±100	24546	C4-1/8-T0-1002-F
A54R30	2100-3161	6	2		RESISTOR-TRMR 20K 10% C SIDE-ADJ 17-TRN	02111	43P203
A54R31	0698-3136	8	2		RESISTOR 17 8K 1% .125W F TC=0±100	24546	C4-1/8-T0-1782-F
A54R32	2100-3054	6	1		RESISTOR-TRMR 50K 10% C SIDE-ADJ 17-TRN	02111	43P503
A54R33	0757-0199	3	1		RESISTOR 21 5K 1% .125W F TC=0±100	24546	C4-1/8-T0-2152-F
A54R34	0698-3158	4	1		RESISTOR 23 7K 1% .125W F TC=0±100	24546	C4-1/8-T0-2372-F
A54R35	0757-0438	3	2		RESISTOR 5.11K 1% .125W F TC=0±100	24546	C4-1/8-T0-5111-F
A54R36	2100-3161	6			RESISTOR-TRMR 20K 10% C SIDE-ADJ 17-TRN	02111	43P203
A54R37	0757-0461	2	2		RESISTOR 68 1K 1% .125W F TC=0±100	24546	C4-1/8-T0-6812-F
A54R38	0757-0461	2			RESISTOR 68 1K 1% .125W F TC=0±100	24546	C4-1/8-T0-6812-F
A54R39	0757-0442	9			RESISTOR 10K 1% .125W F TC=0±100	24546	C4-1/8-T0-1002-F
A54R40	0757-0442	9			RESISTOR 10K 1% .125W F TC=0±100	24546	C4-1/8-T0-1002-F
A54R41	0757-0438	3			RESISTOR 5.11K 1% .125W F TC=0±100	24546	C4-1/8-T0-5111-F
A54R42	0757-0442	9			RESISTOR 10K 1% .125W F TC=0±100	24546	C4-1/8-T0-1002-F
A54R43	0757-0442	9			RESISTOR 10K 1% .125W F TC=0±100	24546	C4-1/8-T0-1002-F
A54R44					NOT ASSIGNED		
A54R45	0757-0442	9			RESISTOR 10K 1% .125W F TC=0±100	24546	C4-1/8-T0-1002-F
A54R46	0757-0447	4	1		RESISTOR 16 2K 1% .125W F TC=0±100	24546	C4-1/8-T0-1622-F
A54R47	0757-0442	9			RESISTOR 10K 1% .125W F TC=0±100	24546	C4-1/8-T0-1002-F
A54R48	0698-3136	8			RESISTOR 17 8K 1% .125W F TC=0±100	24546	C4-1/8-T0-1782-F
A54R49	0757-1094	9	1		RESISTOR 1.47K 1% .125W F TC=0±100	24546	C4-1/8-T0-1471-F
A54R50	0698-3440	7			RESISTOR 196 1% .125W F TC=0±100	24546	C4-1/8-T0-196R-F
A54R51	0698-3430	5			RESISTOR 21 5 1% .125W F TC=0±100	03888	PME55-1/8-T0-21R5-F
A54R52	0698-3430	5			RESISTOR 21 5 1% .125W F TC=0±100	03888	PME55-1/8-T0-21R5-F
A54R53	0698-3430	5			RESISTOR 21 5 1% .125W F TC=0±100	03888	PME55-1/8-T0-21R5-F
A54TP1	0360-0535	0	7		TEST POINT	28480	0360-0535
A54TP2	0360-0535	0			TEST POINT	28480	0360-0535
A54TP3	0360-0535	0			TEST POINT	28480	0360-0535
A54TP4	0360-0535	0			TEST POINT	28480	0360-0535
A54TP5	0360-0535	0			TEST POINT	28480	0360-0535
A54TP6	0360-0535	0			TEST POINT	28480	0360-0535
A54TP7	0360-0535	0			TEST POINT	28480	0360-0535
A54U1	1826-0367	5	1		IC 78M05C V RGLTR TO-39	04713	MC78M05CG
A54U2	1826-0471	2	3		IC OP AMP LOW-DRIFT TO-99 PKG	28480	1826-0471
A54U3	1826-0512	2	1		IC 78M15C V RGLTR TO-39	04713	MC78M15CG
A54U4	1826-0471	2			IC OP AMP LOW-DRIFT TO-99 PKG	28480	1826-0471
A54U5	1826-0471	2			IC OP AMP LOW-DRIFT TO-99 PKG	28480	1826-0471
A54U6	1826-0308	4	1		IC CONV 12-B-D/A 24-DIP-C PKG	24355	AD562KD/BIN
A54U7	1820-0138	6	1		IC OP AMP GP 14-DIP-C PKG	29832	S52
A54U8	1826-0026	3	1		IC COMPARATOR PRCN TO-99 PKG	01295	LM311L
A54U9	1820-1112	8	1		IC FF TTL LS D-TYPE POS-EDGE-TRIG	01295	SN74LS74AN
A54U10	1810-0206	8	2		NETWORK-RES 8-SIP10 0K OHM X 7	01121	208A103

A54 YO Pretune/Delay Compensation Component-Level Troubleshooting

Table A54-2. A54 YO Pretune/Delay Compensation Replaceable Parts

Reference Designation	HP Part Number	C D	Qty	Description	Mfr Code	Mfr Part Number
A54U11	1820-1196	8	2	IC FF TTL LS D-TYPE POS-EDGE-TRIG COM NETWORK-RES 8-SIP10.0K OHM X 7	01295	SN74LS174N
A54U12	1810-0206	8			01121	208A103
A54U13	1820-1196	8			01295	SN74LS174N
A54U14	1826-0785	1			01295	TL072ACJG
A54U15	1826-0798	6	1	IC CONV 8-B-D/A	18324	NE5018F
A54U16	1826-0928	4	1	D/A 8-BIT 22-CERDIP BPLR	02910	NE5118F
A54VR1	1902-0692	1	1	DIODE-ZNR 6.3V 1% DO-7 PD= .4W TC= +.001%	28480	1902-0692

A55 YO Driver Assembly Circuit Description

ASSEMBLY PURPOSE

The YO Driver:

- Acts as a voltage to current converter to transform the Pretune voltage (sensitivity = -2.5 Volts/GHz) to YO main coil current (sensitivity is approximately 24 ma/GHz).
- Provides the summing point for the low frequency portion (less than 100 Hz) of the YO phase-locked loop error voltage (YO TUNE).
- Provides the summing point for the YO delay compensation voltage (VCOMP).
- Provides the summing point for the YO coil offset current.
- Provides the driver circuitry for the YO retrace kick pulse.

DISCRETE OPERATIONAL-AMPLIFIER (BLOCK A)

The discrete operational amplifier is arranged in a standard configuration. Q6 provides the differential input with TP4 the inverting input and TP5 the noninverting input. The Q4 circuitry forms a current source for biasing the input stage. C1 is for noise filtering; CR2 and CR3 provide temperature stabilization. CR1 limits the differential input voltage to the operational amplifier.

Q2, Q5, R8 and R9 form a current mirror to provide maximum gain from the differential input to the single ended output. Q3 is the output stage of the discrete operational amplifier stage. R10 and C2 are for loop compensation.

The gain of the YO driver is set by an adjustable voltage divider formed by R1 through R4. This adjustment is made at the high end of the YO frequency range (i.e., 6.99 GHz). The GAIN adjustment is interactive with the OFFSET adjustment, R47 in YO error/offset summing amplifier (block E), which is made at the low end of the frequency range (2.3 GHz). See the adjustment section.

R13, R20, and C3 form a noise filter used in the CW and MANUAL modes. In YO sweeps, however, to avoid unwanted delay in the response of YO driver, the filter can be switched out by the filter switch (block D). This filter also severely limits the slew rate of the discrete operational amplifier so Q8 and Q10 serve as speed up transistors by shunting resistor R13 when the operational amplifier is changing state and when the voltage across the resistor is sufficient to turn on one of the other of the transistors. Q7 is a current limiter stage.

VOLTAGE-TO-CURRENT CONVERTER (BLOCK B)

Transistors Q9 and Q11 are connected as a complementary darlington pair. This circuit, together with A47Q1 on the A47 sense resistor assembly, function like a compound PNP Transistor with its emitter connected to the sense resistor, its base connected to the output of the discrete operational amplifier, and its collector connected to the YO main coil. See Figure A55-1. The sense resistor, A46R6, and A47Q1 are mounted externally to the assembly for heat sinking.

CR6, CR7, CR8 and VR1 protect the darlington transistor against the inductive voltage spikes generated by the YO coil whenever a step change in current is desired. C4, C25 and R23 stabilize the compound PNP transistor. Oscillation of this stage is aggravated by the inductance of the leads connecting the related components. R24 provides for a slight bias current through Q11 and defines the impedance seen by the base of A47Q1. C26 bypasses the base-emitter junction of Q10 and improves the radiated susceptibility performance of the instrument.

VCOMP SWITCH LOGIC (BLOCK C)

This circuitry determines when the (VCOMP) delay compensation voltage is applied to the main summing amplifier (block F). When both HSP (high sweep), and HCEN (high compensation enable) inputs are high, the output at U5B is low, turning on Q1 in the main summing amplifier (block F). This allows the VCOMP signal to be summed with the YO TUNE input. When either HSP or HCEN are low, Q1 is turned off, removing the VCOMP signal. HCEN is a latched line that is high whenever the sweep width is greater than 50 MHz. R40 is a pull-up resistor to ensure that the output of U5B goes high enough to turn off Q1.

FILTER SWITCH (BLOCK D)

In YO sweeps, switch Q13 is turned on by LYSP (low YO sweep). This grounds R22 in discrete operational amplifier (block A) which sources current through R13 and R20, thus turning on Q10 and providing a straight through path in shunt with the one resistor, R13. This bypasses the filter described in block A and eliminates its associated delay.

YO ERROR/OFFSET SUMMING AMPLIFIER (BLOCK E)

The OFFSET voltage is derived from a 6.2 volt reference zener. R47 provides an adjustment for this voltage and R48 with C15 provide noise filtering. The YO phase-locked loop error voltage, YO TUNE, from the A49 YO loop phase detector (A49J2) is summed with the offset voltage at U2.

MAIN SUMMING AMPLIFIER (BLOCK F)

The delay compensation voltage (VCOMP) from A54 YO pretune/delay compensation assembly is added to the output of YO error/offset summing amplifier (block E). Q1 switches VCOMP in and out. The resultant voltage (SUM, TP2) is injected through R29 as a current into the summing node of the voltage-to-current converter (block B).

POWER SUPPLIES (BLOCK G)

The power supply filtering is the standard shunt capacitance, series resistance type.

KICK PULSE DRIVER (BLOCK H)

The (low = true) kick pulse signal, LKICK, comes from the A54 YO pretune assembly. This signal turns on Q14 which enables the current source made up of Q12 and R67. The current source sinks approximately 60 mA of drive current away from the YO main coil, briefly tuning the YO 2.5 GHz lower in frequency, and eliminating magnetic hysteresis. R68 insures that CR11 is reverse biased when the kick pulse is not present. This disconnects the kick pulse drive circuitry from the remaining YO circuitry.

A55 YO Driver Assembly Circuit Description

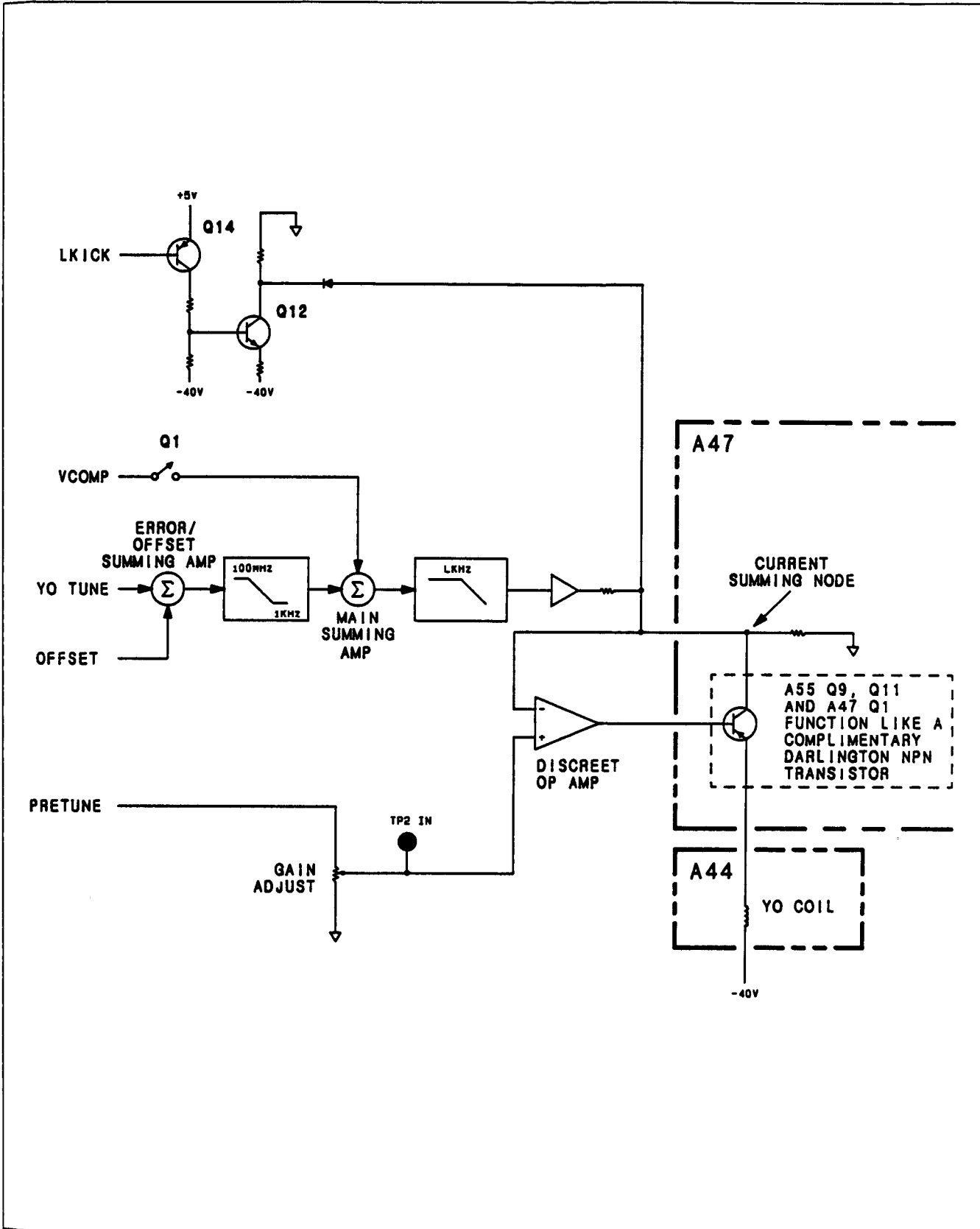

Figure A55-1. A55 YO Driver Simplified Diagram

A55 YO Driver Assembly Component-Level Troubleshooting

Table A55-1. A55 YO Driver P1 Pin I/O

Pin	Mnemonic	Levels	Source	Destination
1 16	LKICK +20V	TTL +20V	A54P1-19 XA52P1-16, 40	H *G
2 17	+5.2V +5.2V	+5.2V +5.2V	XA52P1-17, 18, 41, 42 XA52P1-17, 18, 41, 42	*G *G
3 18	-40V/-40V SENSE (-) -40V/-40V SENSE (-)	-40V XA53P1-11, 30/XA53P1-23	XA53P1-11, 30/XA53P1-23 *G/NOT USED	*G/NOT USED
4 19	-10V -10V	-10V -10V	XA53P1-12, 13, 31, 32 XA53P1-12, 13, 31, 32	*G *G
5 20	GND GND	0V 0V	A62 STAR GND A62 STAR GND	*G *G
6 21	GND GND	0V 0V	A62 STAR GND A62 STAR GND	*G *G
7 22	LYSP HSP	TTL (LOW TRUE) TTL (HIGH TRUE)	XA59P1-11 XA57P1-13	C D *C
8 23	PRETUNE PRETUNE	-25V/GHZ, 0V = 2.3 GHZ -25V/GHZ, 0V = 2.3 GHZ	XA54P1-24 XA54P1-24	*A *A
9 24	VCOMP YO TUNE	-26 MHZ/VOLT 0V ± 6V	XA54P1-27 E	F A62J6-SMC CENTER
10 25	RGND RGND	0V 0V	STAR GND POINT STAR GND POINT	*H *H
11 26	RGND RGND	0V 0V	STAR GND POINT STAR GND POINT	*H *H
12 27	SR FBK SR FBK	-5V TO -17V -5V TO -17V	A A	A62J29-2 A62J29-2
13 28	SR PWR SR PWR	-5V TO -17V -5V TO -17V	B B	A62J29-3 A62J29-3
14 29	HCEN YOXISTB	TTL (HIGH TRUE) -30V TO -39V	XA59P1-67 B	XA55P1-14 A62J29 PIN 4
15 30	YO COIL + YO COIL +	-40V TO -20V -40V TO -20V	B B	* *

A single letter in the source or destination column refers to a function block on this assembly schematic.

An asterisk (*) denotes multiple sources or destinations; refer to the A62 motherboard wiring list for a complete representation of signal sources and destinations.

A55 YO Driver Assembly Component-Level Troubleshooting

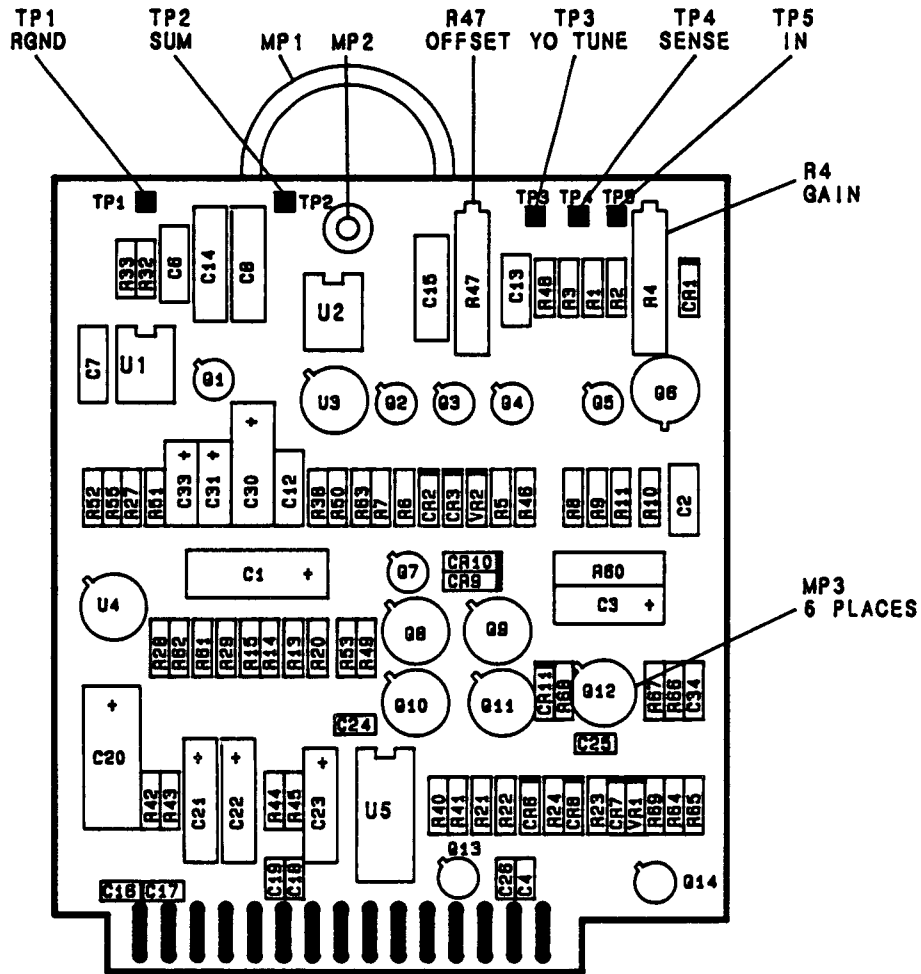

HP Part Number: 08340-60215

Figure A55-2. A55 YO Driver Component Location Diagram

RESISTANCE VALUES ARE IN OHMS, CAPACITANCE IN MICROFARADS, AND INDUCTANCE IN MICROHENRIES UNLESS OTHERWISE NOTED.

THE SHIELDING CONDUCTOR OF A47W1 IS GROUND AT SCREW CONNECTION IMMEDIATELY IN FRONT OF A62J23

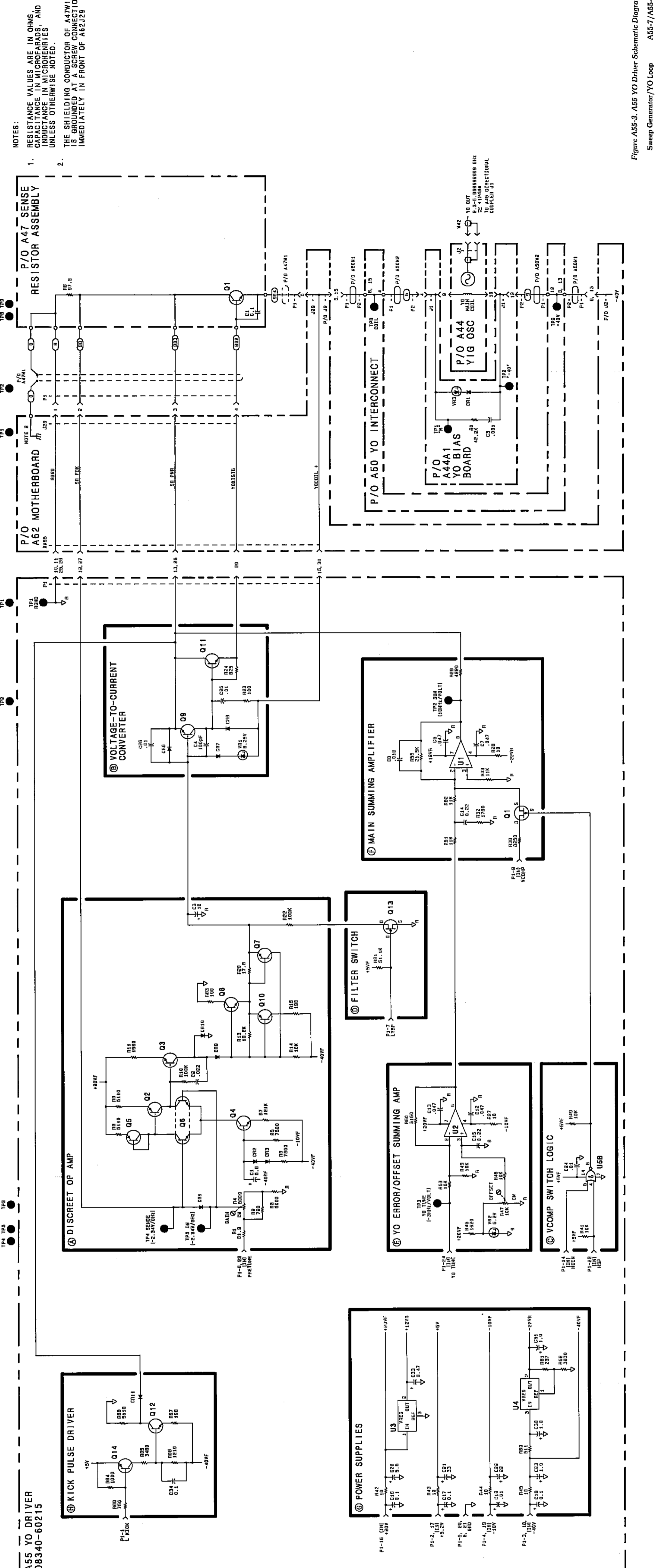

NOTES:

1. RESISTANCE VALUES ARE IN OHMS, CAPACITANCE IN MICROFARADS, AND INDUCTANCE IN MICROHENRIES UNLESS OTHERWISE NOTED.
2. THE SHIELDING CONDUCTOR OF A47W1 IS GROUND AT SCREW CONNECTION IMMEDIATELY IN FRONT OF A62J23

Figure A55-3. A55 YO Driver Schematic Diagram

Sweep Generator/YO Loop A55-7/A55-8

A55 YO Driver Assembly Component-Level Troubleshooting

Table A55-2. A55 YO Driver Replaceable Parts

Reference Designation	HP Part Number	C D	Qty	Description	Mfr Code	Mfr Part Number
A55	08340-60215	8	1	YO DRIVER	28480	08340-60215
A55C1	0180-2140	5	2	CAPACITOR-FXD 5 6UF ± 10% 50VDC TA	56289	150D565X9050R2
A55C2	0160-4833	5	1	CAPACITOR-FXD 022UF ± 10% 100VDC CER	28480	0160-4833
A55C3	0180-2139	2	1	CAPACITOR-FXD 10UF ± 20% 60VDC TA	06001	69F177G7
A55C4	0160-3877	5	1	CAPACITOR-FXD 100PF ± 20% 200VDC CER	28480	0160-3877
A55C5				NOT ASSIGNED		
A55C6	0160-4834	6	4	CAPACITOR-FXD 047UF ± 10% 100VDC CER	28480	0160-4834
A55C7	0160-4834	6		CAPACITOR-FXD 047UF ± 10% 100VDC CER	28480	0160-4834
A55C8	0160-0302	5	1	CAPACITOR-FXD 018UF ± 10% 200VDC POLYE	28480	0160-0302
A55C9-11				NOT ASSIGNED		
A55C12	0160-4834	6		CAPACITOR-FXD 047UF ± 10% 100VDC CER	28480	0160-4834
A55C13	0160-4834	6		CAPACITOR-FXD 047UF ± 10% 100VDC CER	28480	0160-4834
A55C14	0160-4281	3	2	CAPACITOR-FXD 22UF ± 10% 50VDC	84411	HEW 249
A55C15	0160-4281	3		CAPACITOR-FXD 22UF ± 10% 50VDC	84411	HEW 249
A55C16	0160-3879	7	7	CAPACITOR-FXD 01UF ± 20% 100VDC CER	28480	0160-3879
A55C17	0160-3879	7		CAPACITOR-FXD 01UF ± 20% 100VDC CER	28480	0160-3879
A55C18	0160-3879	7		CAPACITOR-FXD 01UF ± 20% 100VDC CER	28480	0160-3879
A55C19	0160-3879	7		CAPACITOR-FXD 01UF ± 20% 100VDC CER	28480	0160-3879
A55C20	0180-2140	5		CAPACITOR-FXD 5 6UF ± 10% 50VDC TA	56289	150D565X9050R2
A55C21	0180-0229	7	1	CAPACITOR-FXD 33UF ± 10% 10VDC TA	56289	150D336X9010B2
A55C22	0180-0228	6	1	CAPACITOR-FXD 22UF ± 10% 15VDC TA	56289	150D228X9015B2
A55C23	0180-2505	6	2	CAPACITOR-FXD 1UF ± 10% 75VDC TA	56289	150D105X9075B2
A55C24	0160-3879	7		CAPACITOR-FXD 01UF ± 20% 100VDC CER	28480	0160-3879
A55C25	0160-3879	7		CAPACITOR-FXD 01UF ± 20% 100VDC CER	28480	0160-3879
A55C26	0160-3879	7		CAPACITOR-FXD 01UF ± 20% 100VDC CER	28480	0160-3879
A55C27-29				NOT ASSIGNED		
A55C30	0180-2505	6		CAPACITOR-FXD 1UF ± 10% 75VDC TA	56289	150D105X9075B2
A55C31	0180-0230	0	1	CAPACITOR-FXD 1UF ± 20% 50VDC TA	56289	150D105X0050A2
A55C32				NOT ASSIGNED		
A55C33	0180-2148	3	1	CAPACITOR-FXD .47UF ± 20% 50VDC TA	56289	150D474X0050A2
A55C34	0160-4835	7	1	CAPACITOR-FXD 1UF ± 10% 50VDC CER	02798	CACO4X7R104K050A
A55CR1	1901-0033	2	6	DIODE-GEN PRP 180V 200MA DO-7	28480	1901-0033
A55CR2	1901-0033	2		DIODE-GEN PRP 180V 200MA DO-7	28480	1901-0033
A55CR3	1901-0033	2		DIODE-GEN PRP 180V 200MA DO-7	28480	1901-0033
A55CR4, 5				NOT ASSIGNED		
A55CR6	1901-0033	2		DIODE-GEN PRP 180V 200MA DO-7	28480	1901-0033
A55CR7	1901-0033	2		DIODE-GEN PRP 180V 200MA DO-7	28480	1901-0033
A55CR8	1901-0033	2		DIODE-GEN PRP 180V 200MA DO-7	28480	1901-0033
A55CR9	1901-0050	3	3	DIODE-SWITCHING 80V 200MA 2NS DO-35	00046	1N4150
A55CR10	1901-0050	3		DIODE-SWITCHING 80V 200MA 2NS DO-35	00046	1N4150
A55CR11	1901-0050	3		DIODE-SWITCHING 80V 200MA 2NS DO-35	00046	1N4150
A55MP1	5040-6851	2	1	EXTRACTOR	28480	5040-6851
A55MP2	5000-9043	6	1	PIN:P C. BOARD EXTRACTOR	28480	5000-9043
A55Q1	1855-0278	8	2	TRANSISTOR J-FET 2N5116 P-CHAN D-MODE	17856	2N5116
A55Q2	1853-0007	7		TRANSISTOR PNP 2N3251 SI TO-18 PD=360MW	04713	2N3251
A55Q3	1853-0451	5	2	TRANSISTOR PNP 2N3798 SI TO-18 PD=360MW	01295	2N3799
A55Q4	1854-0404	0	1	TRANSISTOR NPN SI TO-18 PD=360MW	28480	1854-0404
A55Q5	1853-0007	7	2	TRANSISTOR PNP 2N3251 SI TO-18 PD=360MW	04713	2N3251
A55Q6	1854-0475	5	1	TRANSISTOR-DUAL NPN PD=750MW	28480	1854-0475
A55Q7	1853-0451	5		TRANSISTOR PNP 2N3799 SI TO-18 PD=360MW	01295	2N3799
A55Q8	1854-0022	8	1	TRANSISTOR NPN SI TO-39 PD=700MW	07263	S17843
A55Q9	1853-0038	4	1	TRANSISTOR PNP SI TO-39 PD=1W FT=100MHZ	28480	1853-0038
A55Q10	1853-0012	4	1	TRANSISTOR PNP 2N2904A SI TO-39 PD=600MW	01295	2N2904A
A55Q11	1854-0232	2	1	TRANSISTOR NPN SI TO-39 PD=1W FT=15MHZ	28480	1854-0232
A55Q12	1854-0361					
A55Q13	1855-0278	8		TRANSISTOR J-FET 2N5116 P-CHAN D-MODE	17856	2N5116
A55Q14	1853-0281	9	1	TRANSISTOR PNP 2N2907A SI TO-18 PD=400MW	04713	2N2907A
A55R1	0757-0276	7	1	RESISTOR 61 9 1% 125W F TC=0±100	24546	C4-1/8-T0-6192-F
A55R2	0699-0961	3	1	RESISTOR 720 1% 1W F TC=0+4	28480	0699-0961
A55R3	0699-0059	0	1	RESISTOR 5K 1% 1W F TC=0±5	28480	0699-0059
A55R4	2100-3056	8	1	RESISTOR-TRMR 5K 10% C SIDE-ADJ 17-TRN	02111	43P502
A55R5	0757-0440	7	2	RESISTOR 7 5K 1% 125W F TC=0±100	24546	C4-1/8-T0-7501-F
A55R6	0757-0440	7		RESISTOR 7 5K 1% 125W F TC=0±100	24546	C4-1/8-T0-7501-F
A55R7	0757-0487	8	1	RESISTOR 121K 1% 125W F TC=0±100	24546	C4-1/8-T0-1213-F
A55R8	0757-0438	3	2	RESISTOR 5 11K 1% 125W F TC=0±100	24546	C4-1/8-T0-5111-F
A55R9	0757-0438	3		RESISTOR 5 11K 1% 125W F TC=0±100	24546	C4-1/8-T0-5111-F
A55R10	0757-0465	6	2	RESISTOR 100K 1% 125W F TC=0±100	24546	C4-1/8-T0-1003-F

A55 YO Driver Assembly Component-Level Troubleshooting

Table A55-2. A55 YO Driver Replaceable Parts

Reference Designation	HP Part Number	C D	Qty	Description	Mfr Code	Mfr Part Number
A55R11	0698-0083	8	1	RESISTOR 1.98K 1% .125W F TC=0±100	24546	C4-1/8-TO-1961-F
A55R12				NOT ASSIGNED		
A55R13	0698-3157	3	1	RESISTOR 19.8K 1% .125W F TC=0±100	24546	C4-1/8-TO-1962-F
A55R14	0757-0442	9	6	RESISTOR 10K 1% .125W F TC=0±100	24546	C4-1/8-TO-1002-F
A55R15	0698-3440	7	1	RESISTOR 198 1% .125W F TC=0±100	24546	C4-1/8-TO-196R-F
A55R16-19				NOT ASSIGNED		
A55R20	0757-0294	9	1	RESISTOR 17.8 1% .125W F TC=0±100	19701	MF4C1/8-TO-17R8-F
A55R21	0757-0458	7	1	RESISTOR 51.1K 1% .125W F TC=0±100	24546	C4-1/8-TO-5112-F
A55R22	0757-0465	6		RESISTOR 100K 1% .125W F TC=0±100	24546	C4-1/8-TO-1003-F
A55R23	0757-0401	0	2	RESISTOR 100 1% .125W F TC=0±100	24546	C4-1/8-TO-101-F
A55R24	0757-0421	4	1	RESISTOR 825 1% .125W F TC=0±100	24546	C4-1/8-TO-825R-F
A55R25, 26				NOT ASSIGNED		
A55R27	0757-0346	2	6	RESISTOR 10 1% .125W F TC=0±100	24546	C4-1/8-TO-10R0-F
A55R28	0757-0346	2		RESISTOR 10 1% .125W F TC=0±100	24546	C4-1/8-TO-10R0-F
A55R29	0698-3154	0	1	RESISTOR 4.22K 1% .125W F TC=0±100	24546	C4-1/8-TO-4221-F
A55R30, 31				NOT ASSIGNED		
A55R32	0757-0278	9	1	RESISTOR 1.78K 1% .125W F TC=0±100	24546	C4-1/8-TO-1781-F
A55R33	0757-0443	0	3	RESISTOR 11K 1% .125W F TC=0±100	24546	C4-1/8-TO-1102-F
A55R34-37				NOT ASSIGNED		
A55R38	0757-0441	8	1	RESISTOR 8.25K 1% .125W F TC=0±100	24546	C4-1/8-TO-8251-F
A55R39				NOT ASSIGNED		
A55R40	0757-0442	9		RESISTOR 10K 1% .125W F TC=0±100	24546	C4-1/8-TO-1002-F
A55R41	0757-0442	9		RESISTOR 10K 1% .125W F TC=0±100	24546	C4-1/8-TO-1002-F
A55R42	0757-0346	2		RESISTOR 10 1% .125W F TC=0±100	24546	C4-1/8-TO-10R0-F
A55R43	0757-0346	2		RESISTOR 10 1% .125W F TC=0±100	24546	C4-1/8-TO-10R0-F
A55R44	0757-0346	2		RESISTOR 10 1% .125W F TC=0±100	24546	C4-1/8-TO-10R0-F
A55R45	0757-0346	2		RESISTOR 10 1% .125W F TC=0±100	24546	C4-1/8-TO-10R0-F
A55R46	0757-0428	1	1	RESISTOR 1.62K 1% .125W F TC=0±100	24546	C4-1/8-TO-1621-F
A55R47	2100-3103	6	1	RESISTOR-TRMR 10K 10% C SIDE-ADJ 17-TRN	02111	43P103
A55R48	0757-0442	9		RESISTOR 10K 1% .125W F TC=0±100	24546	C4-1/8-TO-1002-F
A55R49	0757-0442	9		RESISTOR 10K 1% .125W F TC=0±100	24546	C4-1/8-TO-1002-F
A55R50	0757-0279	0	1	RESISTOR 3.16K 1% .125W F TC=0±100	24546	C4-1/8-TO-3161-F
A55R51	0757-0443	0		RESISTOR 11K 1% .125W F TC=0±100	24546	C4-1/8-TO-1102-F
A55R52	0757-0443	0		RESISTOR 11K 1% .125W F TC=0±100	24546	C4-1/8-TO-1102-F
A55R53	0757-0442	9		RESISTOR 10K 1% .125W F TC=0±100	24546	C4-1/8-TO-1002-F
A55R54				NOT ASSIGNED		
A55R55	0757-0199	3	1	RESISTOR 21.5K 1% .125W F TC=0±100	24546	C4-1/8-TO-2152-F
A55R56-59				NOT ASSIGNED		
A55R60	0757-0814	9	1	RESISTOR 511 1% .5W F TC=0±100	28480	0757-0814
A55R61	0698-3442	9	1	RESISTOR 237 1% .125W F TC=0±100	24546	C4-1/8-TO-237R-F
A55R62	0698-3153	9	1	RESISTOR 3.83K 1% .125W F TC=0±100	24546	C4-1/8-TO-3831-F
A55R63	0757-0401	0		RESISTOR 100 1% .125W F TC=0±100	24546	C4-1/8-TO-101-F
A55R64	0757-0280	3	1	RESISTOR 1.2M 1% 1W CF TC=0-500	05524	MCS1/2-1204-F
A55R65	0698-3152	8	1	RESISTOR 3.48K 1% .125W F TC=0±100	03292	CT4-1/8-TO-3481-F
A55R66	0757-0274	5	1	RESISTOR 1M 1% .5W CF TC=0-500	05524	DCS1/2-1004-F
A55R67	0698-3440	7		RESISTOR 198 1% .125W F TC=0±100	24546	C4-1/8-TO-196R-F
A55R68	0757-0438	3		RESISTOR 5.11K 1% .125W F TC=0±100	24546	C4-1/8-TO-5111-F
A55R69	0757-0420	3	1	RESISTOR 4.62K 1% .5W CF TC=0-500	05524	PCS1/2-4621-F
A55TP1	0360-0535	0	5	TERMINAL TEST POINT PCB	00000	ORDER BY DESCRIPTION
A55TP2	0360-0535	0		TERMINAL TEST POINT PCB	00000	ORDER BY DESCRIPTION
A55TP3	0360-0535	0		TERMINAL TEST POINT PCB	00000	ORDER BY DESCRIPTION
A55TP4	0360-0535	0		TERMINAL TEST POINT PCB	00000	ORDER BY DESCRIPTION
A55TP5	0360-0535	0		TERMINAL TEST POINT PCB	00000	ORDER BY DESCRIPTION
A55U1	1826-0783	9	2	IC OP AMP LOW-NOISE 8-DIP-C PKG	52063	XR5534ACN
A55U2	1826-0783	9		IC OP AMP LOW-NOISE 8-DIP-C PKG	52063	XR5534ACN
A55U3	1826-0226	5	1	IC V RGLTR TO-39	07283	78M12HC
A55U4	1826-0558	6	1	IC 337 V RGLTR TO-39	27014	LM337H
A55U5	1820-1197	9	1	IC GATE TTL LS NAND QUAD 2-INP	01295	SN74LS00N
A55VR1	1902-0197	1	1	DIODE-ZNR 82V 5% PD=1W IR=5UA	28480	1902-0197
A55VR2	1902-0625	0	1	DIODE-ZNR 1N829 6 2V 5% DO-7 PD= 25W	04713	1N829

A58 Sweep Generator Circuit Description

ASSEMBLY PURPOSE

The major function of the A58 sweep generator is to generate three voltage ramps:

- VSWP (TP10)
- MKR RMP (TP4)
- 20-30 SWP (TP8)

SWEEP TIME REGISTER (BLOCK A)

U20 and U22 latch digital information from the instrument data bus. The information is then sent to the sweep time DAC (block G). The strobe for these two latches is 1,R1:, WSPTM (write sweep time). U23 is a latched 3-to-8 decoder that latches the information for the sweep time switch drivers. U23 is latched using the same strobe as U20 and U22.

RESET REGISTER (BLOCK B)

U25 and U27 latch information from the instrument data bus and direct it to the reset DAC in block C. The latch strobe is WRDAC (Write Reset DAC 1,R2:). U24 and U26 contain pull-up resistors to back bias the outputs of U25 and U27 when the outputs are high. This keeps noise on the bus from getting to the reset DAC (block C).

RESET DAC (BLOCK C)

This is a current output DAC. It is referenced to the $-7V$ voltage reference (block D), and its output goes to the summing amplifier (block L). R1, R19 and R20 set the gain of the DAC. C19 provides DAC compensation.

VOLTAGE REFERENCE (BLOCK D)

The reference voltage is derived from VR1, a low noise, low TC, reference diode. R3 maintains a constant current through the diode, and R18 together with C1 give noise filtering. Operational amplifier U15 buffers and provides the gain necessary to make the reference voltage nominally $-7V$. R2 and R17 set the gain of U15.

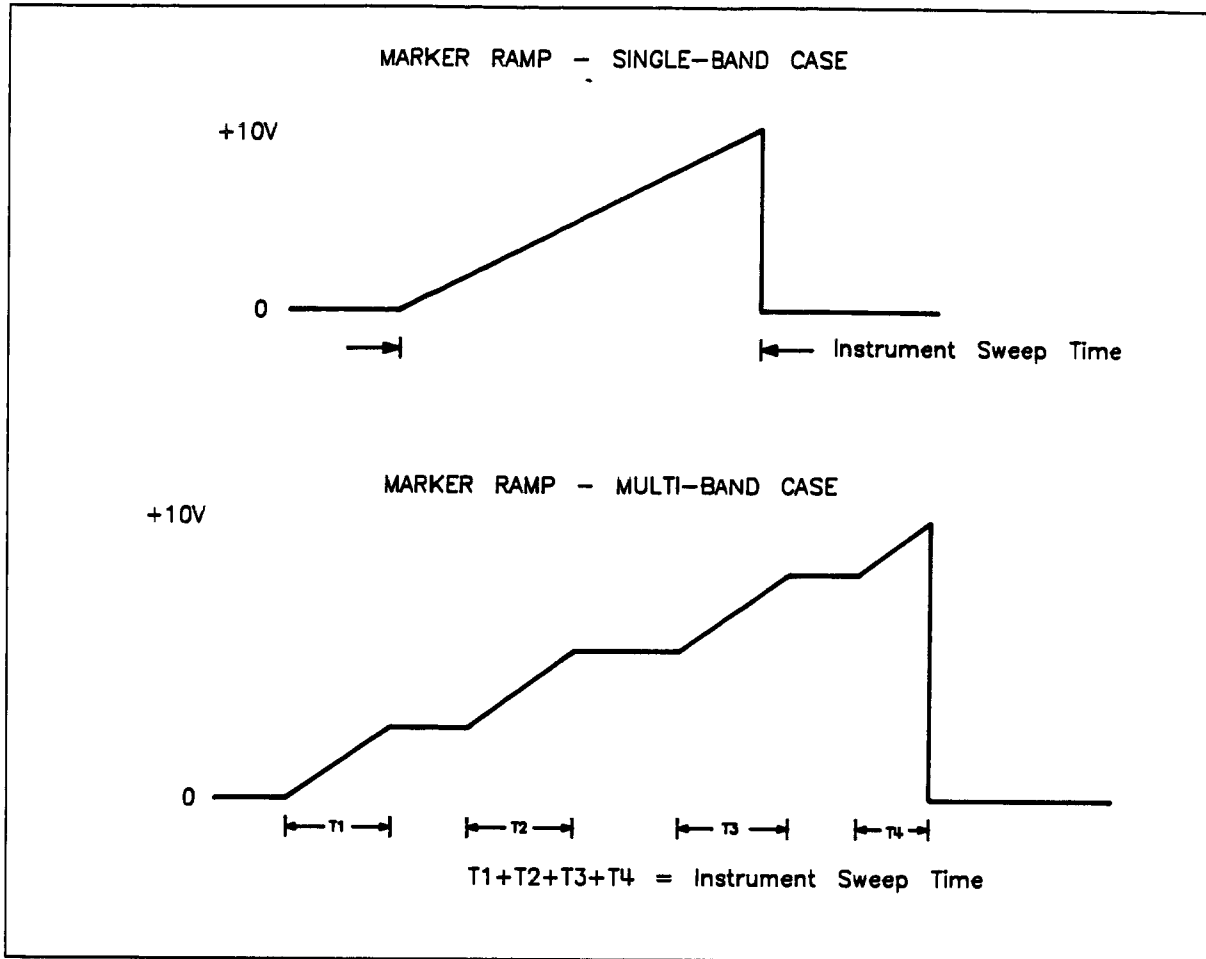

Figure A58-1. Typical Marker Ramp Waveforms

SWEEP WIDTH REGISTER (BLOCK E)

U34 is a latched 3 to 8 decoder that latches information from the instrument data bus and feeds it to the sweep width range switch driver (block F). A given switch driver is selected when the U34 output is a TTL low.

U29 and U31 latch the information for the sweep width DAC (block M). The strobe for the entire sweep width register is 1,R0:, WSPAT (write sweep attenuator). U28 and U30 reverse bias any high output stages in U29 and U31 to keep bus noise from getting into the sweep width DAC.

SWEEP WIDTH RANGE SWITCH DRIVER (BLOCK F)

U35 and U37 are open collector comparators that convert the digital information from the sweep width register (block E) to voltages that will drive the switches in the sweep width range attenuator (block N). The outputs of these comparators are pulled up by U36 to a voltage equal to VSWP. This ensures that the switch drivers can turn on the switches (in the SWP width range attenuator, block N) for every value of VSWP.

SWEEP TIME DAC (BLOCK G)

U2 and U1 take the digital input from the sweep time register (block A) and convert it to the appropriate voltage. R39 provides a fixed trim for the gain of U2. C22 provides operational amplifier stabilization.

The voltage at TP1 should be +10 volts when all the input bits to U2 are high. This will occur whenever the selected sweep time is at the low end of a particular decade range (i.e., 10 ms, 100 ms, 1 second, 10 seconds or 100 seconds). As the sweep time is increased the voltage at TP1 will decrease until it is +1 volt at the top end of the particular decade range of sweep time.

SWEEP TIME SWITCH DRIVERS (BLOCK H)

The sweep time switch drivers take the digital input from the sweep time register (block A) and convert it to a voltage that drives switches Q1 through Q4. U3 serves to pull up the open-collector outputs of U4.

When an output of U4 is at ground, the FET that it is connected to is turned on. When the output is at -10 volts, the FET is off.

SWEEP SCALING RESISTORS (BLOCK I)

The sweep time DAC (block G) and the sweep time scaling resistors (block I) function together as a current source that produces a current proportional to the selected sweep time. The higher the current, the shorter the sweep time. The sweep time DAC (block G) produces a voltage that is applied to the sweep time scaling resistors (block I). Because the output of the sweep time scaling resistor block is held at ground, the voltage from the DAC is converted to a current that goes through the virtual ground amplifier (block J) and then into C30 (in block K). In deriving the current, which corresponds to the selected sweep time, the sweep time scaling resistors (block I) select the appropriate decade range, and the sweep time DAC (block G) does the interpolation within the range.

VIRTUAL GROUND AMPLIFIER (BLOCK J)

The input to the ramp generator is a current source formed by the sweep time DAC (block G), the sweep time scaling resistors (block I), and the virtual ground amplifier (block J). Since the non-inverting input of U8 is connected to ground, the operational amplifier will keep its inverting input at ground also. That is, it will create a virtual ground at the virtual ground test point (VGND, TP3). It does this by varying the voltage at the gate of Q5. This varies the resistance of that FET and therefore varies the voltage drop across it. The voltage across C30 (ramp generator, block K) is always negative, and the conventional current flow is always into the source and out of the drain of Q5.

CR2 and CR3 are low leakage diodes used for current steering.

RAMP GENERATOR (BLOCK K)

The ramp generator output, marker ramp, is generated by feeding a constant current into C30. The voltage across the capacitor is buffered and offset to produce the 0 to +10 volt marker ramp. Figure A58-2 is a simplified schematic showing the ramp generating circuitry. These ramp generating circuits operate in one of three distinct modes, depending on the positions of S1 and S2. Since the current source formed by the sweep time scaling resistors (block I) and the sweep time DAC (block G) is always on, the positions of S1 and S2 determine where the current will go.

Sweep Mode

In sweep mode, both S1 and S2 are open, and the current flows into C30.

Hold Mode

The second mode is the pause or hold mode. Here S1 is open and S2 is closed. This turns on the current shunt and diverts the current through through CR3, a current steering diode.

Reset Mode

The third mode is the reset mode. Here S1 is closed and S2 is open, and the current through CR2 is diverted by switch S1 into the output of U14.

A58 Sweep Generator Circuit Description

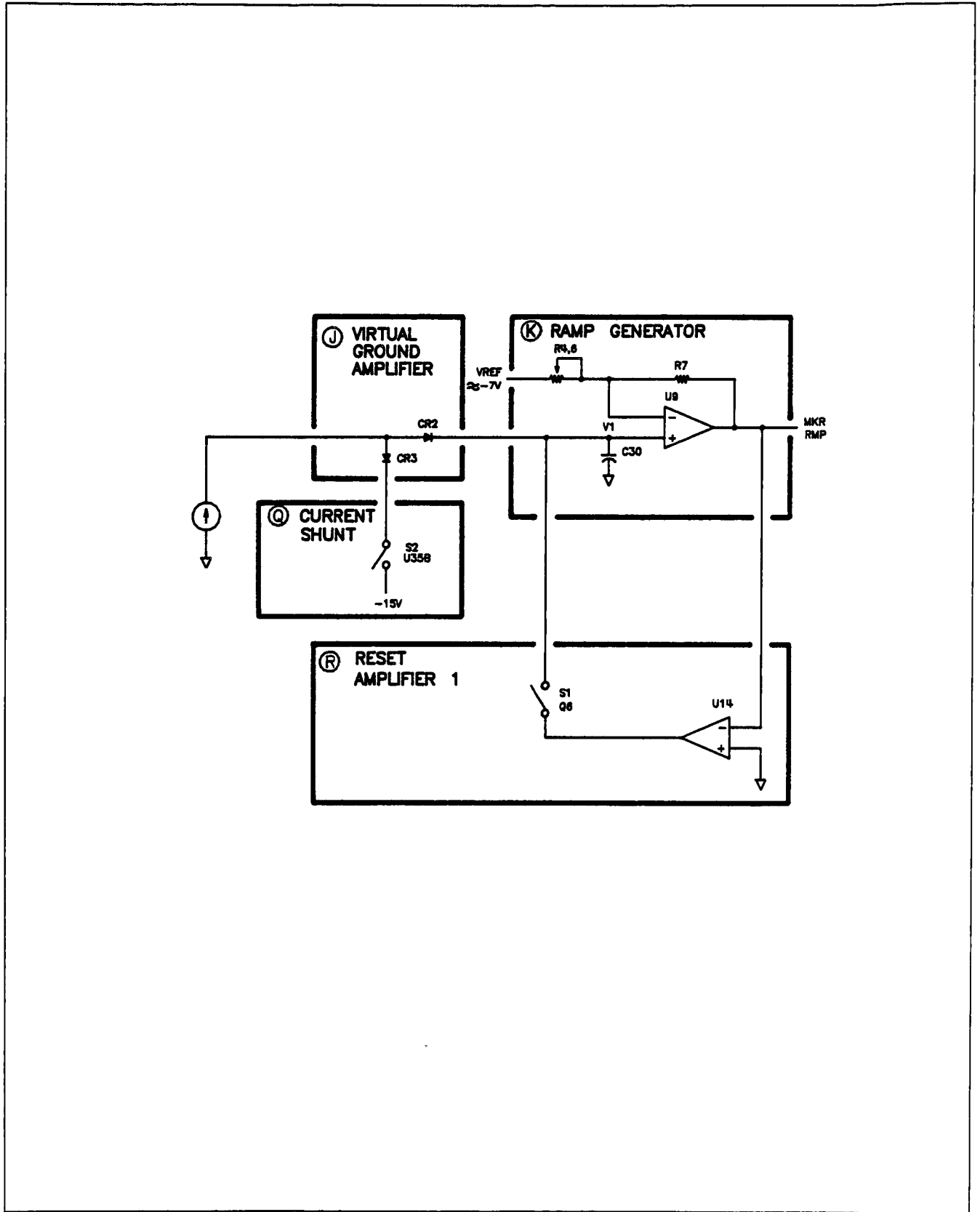

Figure A58-2. Simplified Ramp Generator

When the sweep is reset, switch S1 (Q6) in reset amplifier 1 (block R) is closed. Because the non-inverting input of U14 is grounded, it forces the inverting input to be at ground also. To accomplish this, U14 discharges C30 to its reset voltage and divert the current from the current source away from C30 (once it is reset) so the voltage across C30 does not change. The voltage across C30, after the ramp has been reset, is dependent upon the gain from the non-inverting input to the output of U9, and on the gain from the VREF input to the output of U9.

Because the output of U9 is held at zero by the loop, it is possible to write an equation that describes the voltage at the output of U9 as a function of VREF and the voltage across C30, V1:

$$0 = V1[1 + (4640/1620)] - VREF(4640/1620)$$

$$V1 = VREF \times 0.74$$

$$VREF = \text{approx. } -7 \text{ volts; therefore, } V1 = \text{approx. } -5.18 \text{ volts.}$$

This assumes that potentiometer R4 is set to 0Ω . V1 will vary with VREF.

Marker Ramp in Single-Band Operation

A sweep is initiated by opening switch S1 (Q6) in the reset amplifier 1 (block R). The output of the current source is now directed into C30. This constant current into a constant capacitance causes a voltage across C30 that increases linearly. The output of the ramp generator (block K), MKR RMP, will increase linearly from 0 to +10 volts where the sweep stops. At this point, the voltage across C30 will have increased, become less negative, to a value that is dependent upon the gain from C30 to the output of U9. This gain is $1 + (4640/1620) = 3.864$. So when marker ramp increases by 10 volts, the voltage across C30 increases by $10/3.864 = 2.56$ volts. Thus at the end of any sweep, the voltage across C30 is approximately $-5.18 + 2.56 = -2.62$ volts.

Marker Ramp in Multi-Band Operation

During a multi-band sweep the ramp must pause at each bandcrossing while the instrument phase-locks for the next band. To do this, the current shunt (block Q) is turned on and U35B diverts the output of the current source away from C30. CR2 keeps the current shunt (block Q) from discharging C30. Since current is no longer going into C30, the voltage across it stays constant at the value present when the current shunt is turned on. When the bandcrossing is finished, the current shunt (block Q) is turned off and the ramp generator (block K) continues to sweep up to +10V. This pause in the ramp occurs once at each bandcrossing. CR3 keeps U35B from allowing current flow through CR2 and into C30.

Because any stray current flowing into C30 will cause an error, a guard trace surrounds the entire node comprised of C30, pin 3 of U9, the cathode of CR2, and the source of Q6. To keep the voltage on the guard trace at the same potential as the node that it protects, the voltage at the inverting input of U9 is buffered by U10B and applied to the guard trace.

R4 is the SWEEP TIME adjustment. It varies the gain from C30 to the output of U9. This varies the slope of marker ramp. Since marker ramp is always at +10 volts at the end of a sweep, varying the slope of the ramp changes the time that it takes to complete the sweep (i.e., it changes the sweep time).

SUMMING AMPLIFIER (BLOCK L)

During single band sweeps the output of the summing amplifier is a 0 to -10V ramp. During multi-band sweeps, however, marker ramp will pause at each bandcrossing. At this time VSWP resets to zero for the next phase-lock point. This resetting is accomplished by summing the output of the reset DAC (block C), the ramp generator (block k), and the reset amplifier 2 (block T) via the summing amplifier (block L). At any particular lock point the instrument processor knows what value the marker ramp voltage should be. The processor then programs the reset DAC (block C) to sink a current that is subtracted from the current generated by marker ramp, R8, and R9. This drives the output of U6 toward zero. Because the reset DAC has finite resolution, it is also necessary to provide analog circuitry to bring the output of U6 to exactly 0 volts. reset amplifier 2 (block T) generates an error voltage from the output of the summing amplifier (block L) that, when applied to the summing amplifier, will force that output to zero. R13, SWP GAIN, varies the gain of U6 slightly to adjust for any gain error in the path from MKR RMP to VSWP.

Refer to Figure A58-3, Marker Ramp, RST Ramp, and VSWP Waveforms. The output of the summing amplifier (block L) is a series of voltage ramps, each ramp corresponding to one of the bands being swept. During single band sweeps the output of the summing amplifier is a single 0 to -10V ramp. During multi-band sweeps the output duplicates the slope and voltage differential of Marker Ramp, but is inverted and resets to 0V at each bandcrossing. When the first bandcrossing occurs, MKR RMP pauses and the output of the summing amplifier increases to 0V. When the MKR RMP signal resumes, the summing amplifier output matches the slope and amplitude differential of Marker Ramp from this bandcrossing point to the next. This process repeats until the end of sweep. If the voltage change of each summing amplifier ramp is added together, the total equals 10 volts, regardless of the number of ramps during one sweep.

A58 Sweep Generator Circuit Description

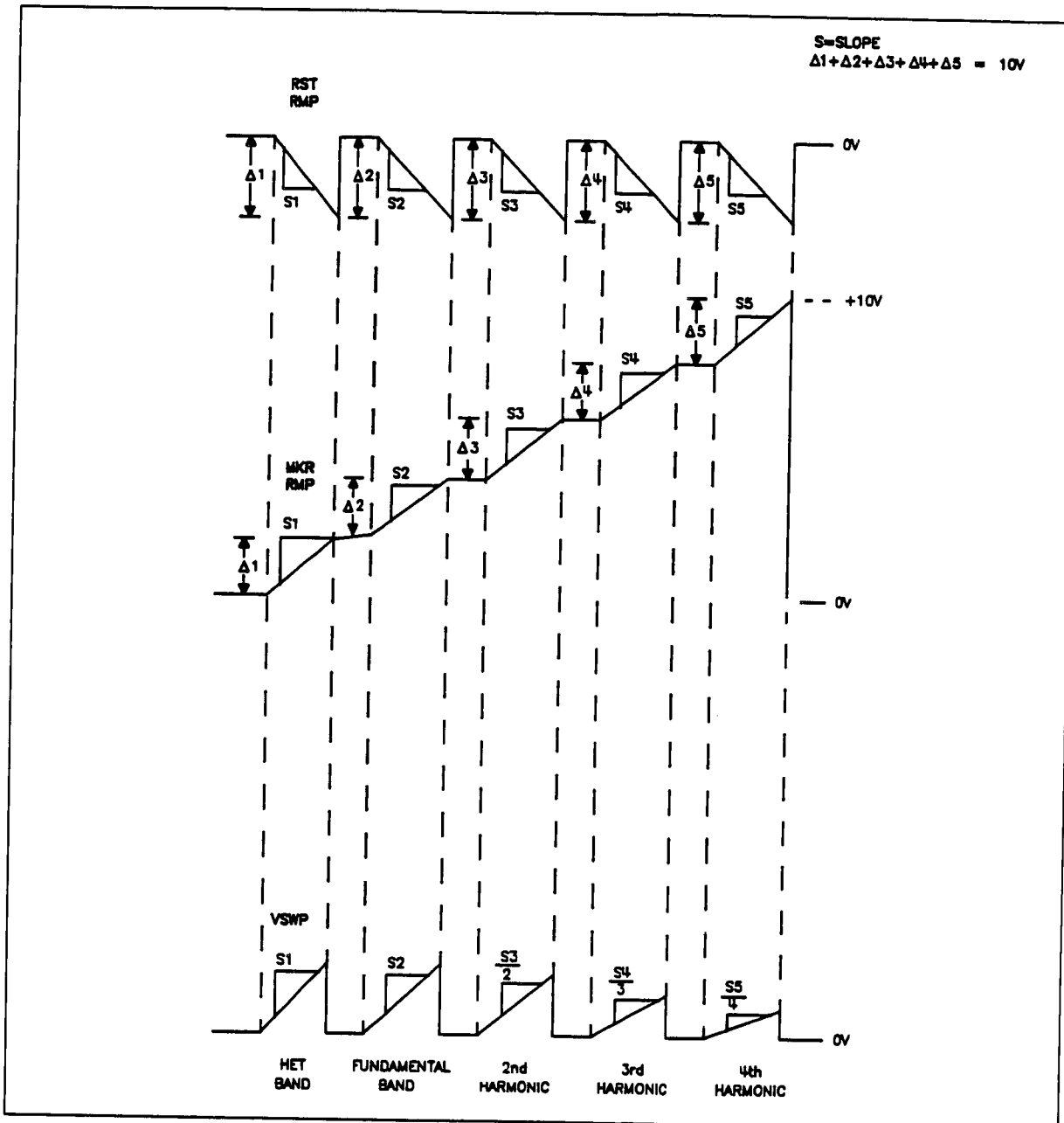

Figure A58-3. Marker Ramp, RST Ramp, and VSWP Waveforms

SWEEP WIDTH DAC (BLOCK M)

The sweep width DAC performs two functions:

- It attenuates its input by a factor of 1, 2, 3 or 4, depending on which harmonic is swept.
- It attenuates its input to give the appropriate sweep width.

The actual sweep width is determined jointly by the sweep width DAC and the sweep width range attenuator (block N). The sweep width range attenuator (block N) selects the correct decade range, and the sweep width DAC interpolates within that selected range. The two sweep width DAC attenuation factors are multiplied by the instrument processor, and the result is applied to the digital input of the sweep width DAC.

CR5 protects U11, in case the +5 volt supply comes up before the +15 volt supply. CR7 protects CR5 in the event that the +15 volt supply is shorted to ground. CR6 protects the output of U11 by keeping it from going much below ground. C39 is a compensation capacitor.

SWEEP WIDTH RANGE ATTENUATOR (BLOCK N)

R58, R59, R61, and R62 form a decade voltage divider stack. The voltage at each node is a factor of 10 smaller than the voltage at the node above it. Q8, Q10, or Q12 is turned on to select the appropriate node. U17 is a unity gain buffer that drives the VSWP line.

In instrument sweeps of greater than 5 GHz, a gain of six is necessary in this block. To accomplish this, Q7 is turned on and the output of U16 is fed to the buffer.

Only one of the FET switches in this block is on at any given time. VSWP is fed back to U36 in sweep width range switch driver (block F) and becomes the supply voltage for the range switch pull-up resistors. When a FET is on, the voltage at its gate is equal to VSWP. When the FET is off, the gate voltage is approximately -15 volts.

In sweep widths where the YO is sweeping less than 5 MHz, the 20-30 Loop is swept and the YO loop stays phase-locked. This scheme gives better noise performance for narrow sweeps. However, for the first range of sweep widths where the YO sweep width is between 500 kHz and 5MHz, the PRETUNE voltage is also swept. The SYTM also uses the PRETUNE voltage to improve the YO/SYTM tracking. In this case Q9 is turned on.

For sweeps narrower than 500 kHz, tracking is not a problem (the SYTM bandwidth is about 25 MHz), and only the 20-30 loop is swept.

NOTE: The sweep mode used, 20-30 loop sweep, or PRETUNE sweep, depends not on the actual instrument sweep width but the YO sweep width. For instance, if the instrument is set to sweep from 17 GHz to 20 GHz, the instrument sweep width is 3 GHz but the YO sweep width is 1 GHz, because the third harmonic of the YO is used.

For YO sweep widths less than 500 kHz, in MANUAL or CW modes, VSWP is turned off To keep any noise from the sweep generator from getting to the pretune DAC and degrading the phase noise performance.

SWEEP BUFFER (BLOCK O)

U18 simply inverts VSWP. This output (BVSWP) is used on the A27 level control assembly ADC to measure VSWP when troubleshooting the sweep circuitry.

SWEEP CONTROL LOGIC (BLOCK P)

The sweep control logic takes HSP (high sweep), LRSP (low reset sweep), and LBX (low bandcross) and generates control signals to drive the front panel sweep LED (LSPLD low sweep LED), reset amplifier 1 (block R), the current shunt, and the reset control logic.

The sweep control logic timing diagram, Figure A58-4, shows what happens at the end of sweep and at bandcrossings. The arrows and numbers indicate the sequence of events as well as the cause and effect relationship of various transitions.

When marker ramp gets to +10 volts, indicating the end of a sweep, LBX (low bandcross, TP6) or HSP (high sweep) going low causes the LOW RESET line to go low. This in turn forces LHLD (low hold sweep, TP12) low, turning on the current shunt (block Q). Finally LSPLD (low sweep LED, U32A pin 3) goes high, turning off the front panel sweep LED.

At the appropriate time the instrument processor asserts LRSP (low reset sweep, TP11) which causes LRESET (low reset, TP13) to go low. This allows reset amplifier 1 (block R) to pull the output of U9 to ground. LRESET going low causes LHLD to go high, turning off the current shunt.

During the repeat-phase-lock sequence, the instrument processor releases LBX and LRSP. These events do not cause any changes on the sweep generator.

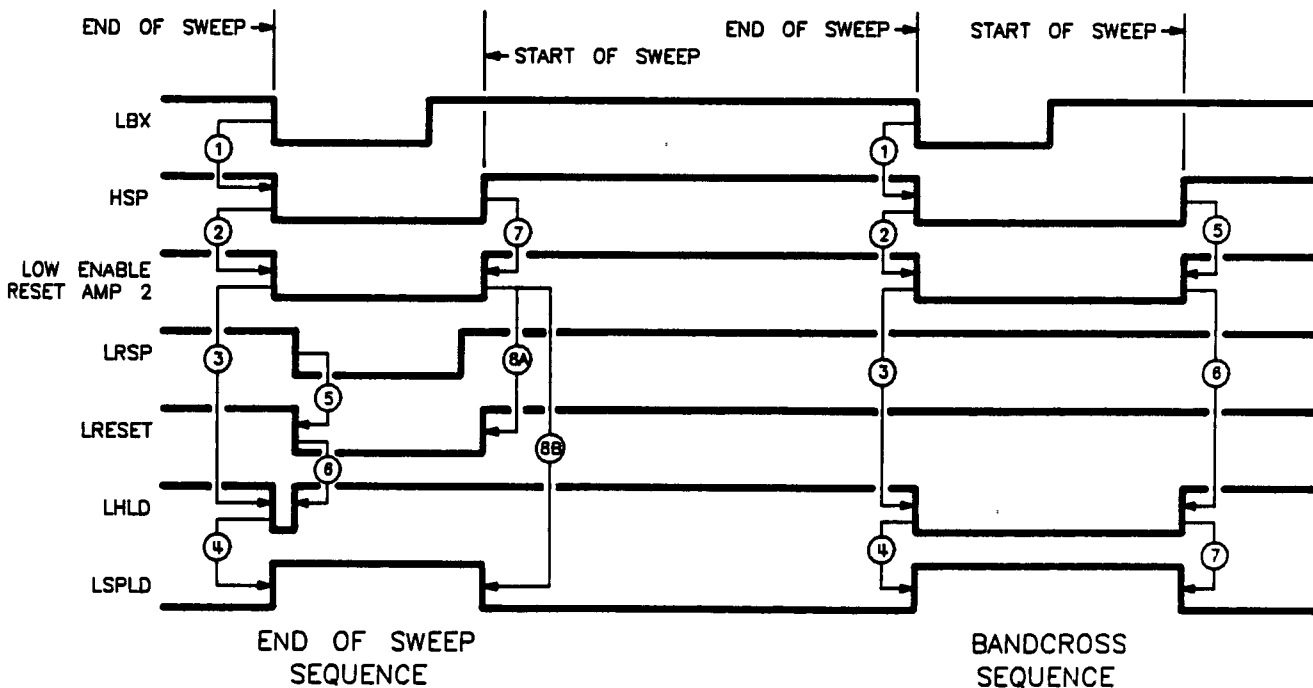

Figure A58-4. Sweep Control Logic Timing Diagram

When the processor is ready for the next sweep, it lets HSP go high. This causes LOW ENABLE RESET AMP 2 to go low. This forces LRESET high and LSPLD low, and the sweep proceeds.

At a bandcrossing, the A57 marker/bandcross assembly pulls down LBX, which is NANDed with HSP at U33C. This enables LOW ENABLE RESET AMP 2, and LSPLD high and LHLD low. This causes the ramp to pause, however, because LRSP is not pulled down by the microprocessor, marker ramp does not reset. When the new information is written to the reset register (block B), its strobe, WRDAC, causes the output of the reset control logic (block S) to go low which in turn forces the output of U6 (block L) to ground.

During the re-phase-lock routine, LBX goes high. When the instrument processor is ready for the next portion of the sweep, it releases HSP, which pulls LOW ENABLE RESET AMP 2 high, ultimately releasing the output of U6. It also makes LHLD go high and LSPLD go low, and the sweep continues.

U33A and U33D are connected as an R/S flip-flop. As long as only one of its inputs (U33A pin 1, U33D pin 12) is low at any given time, its outputs (U33A pin 3, U33D pin 11) will be the opposite TTL level. That is, if one is high, the other will be low. When the instrument is in the CW or MANUAL mode, LBX and HSP are high while LRSP is low. This causes both outputs of the flip-flop to be high.

CURRENT SHUNT (BLOCK Q)

When the voltage at the non-inverting input of U35B is a TTL logic low, <1.4 volts, the output of U35B pulls to -10 volts. This shunts the current coming through Q5, in the virtual ground amplifier (block J), through CR3 and back biases CR2 so that C30 cannot discharge. When the input to U35B is a logic high, its open collector output is pulled to +5 volts by R5. This reverse biases CR3 so that no current is diverted away from C30.

RESET AMPLIFIER 1 (BLOCK R)

When the inverting input of U35A, LRESET, is a TTL logic low, the output of U35A is pulled to +20 volts by R36. This reverse biases CR1 allowing Q6 to turn on through R34. This closes the reset loop shown in Figure A58-2. Since the non-inverting input of U14 is connected to ground, the loop forces the inverting input of U14 to also be at ground. This ensures that Marker Ramp is at zero volts at the start of a sweep.

C26, R43 and R44 are loop compensation components.

RESET CONTROL LOGIC (BLOCK S)

At any phase-lock event LOW ENABLE RESET AMP 2 (block T) goes low. Then the instrument processor writes to the reset register (block B). This low-going strobe, WRDAC, comes to the reset control logic (block S) and forces its output to go low. This puts U13 in reset amplifier 2 (block T) in the sample mode and causes the output of U6 in summing amplifier (block L) to be driven to zero. When a sweep is initiated, LOW ENABLE RESET AMP 2 (block T) goes high. This drives the output of U32B high which puts U13 into the hold mode, thereby opening the loop and allowing the output of U6 to start sweeping.

RESET AMPLIFIER 2 (BLOCK T)

Since the inverting input of U7 is connected to ground, the reset loop will force the non-inverting input to be at ground also. The error voltage generated by U7 is fed to U13, which is a sample and hold. C31 is the sample and hold capacitor. R83 limits the charging rate of C31 and is required to make U13 stable.

When pin 14 of U13 is low, U13 is in the sample mode. This closes the loop and forces the output of U6 (pin 6) in the summing amplifier (block L) to be at ground. When pin 14 of U13 goes high, U13 goes into the hold mode and the loop is opened. As the sweep progresses and the output of U6 ramps up, the output of U13 will not change.

There is a guard trace around the node containing the sample and hold capacitor and U13 pin 11. This trace is connected to the output of U13 to keep it at the same potential as the sensitive end of C31.

OVERSWEEP DETECTOR (BLOCK U)

When the instrument is operating correctly, the A57 marker/bandcross assembly will stop the sweep when the Marker Ramp gets to +10 volts. However, if that assembly is not working and the Marker Ramp reaches +12 volts, the OVERSWEEP DETECTOR pulls down the LBX line which stops the sweep and wakes up the microprocessor. This allows the sweep generator to make repetitive sweeps even when the A57 marker/bandcross assembly is not functioning. This makes troubleshooting much easier. It should be noted however, that in the case when the OVERSWEEP DETECTOR is stopping the sweep, no bandcrossings will occur, and the frequency over which the instrument is sweeping will be incorrect.

LBX is an open-collector line that can be pulled down by several boards. Q13 provides the open-collector function on this assembly and buffers the output of U10A so that by looking at TP5, the HBX test point, one can determine if the sweep generator is the assembly pulling down on LBX. CR9 is a protection diode for the base-emitter junction of Q13, while R45, R46, and CR4 provide hysteresis for the detector function.

POWER SUPPLY FILTERING (BLOCK V)

The filtering is the standard low pass configuration. R48 provides a reference ground for the assembly in the event that the connection between reference ground and chassis ground on the instrument is broken. Q14 and the associated components create a +15V supply referenced to RGND. This supply is used to provide symmetrical $\pm 15V$ supplies. R49 and R50 divide the +20V supply down to +1.4V to be used as the comparator threshold for comparators with TTL inputs. All supplies except +5V and +1.4V are filtered to RGND to prevent digital ground noise from being injected into the analog circuitry via the power supplies.

A58 Sweep Generator Component-Level Troubleshooting

Two basic failure modes are associated with the synthesizer's sweep function:

1. The instrument is not sweeping.
2. The synthesizer is sweeping, but the sweep is incorrect; the frequency limits of the sweep are wrong and/or bandcrossings are not occurring.

If the marker ramp is sweeping and the front panel green LED is blinking, the instrument is considered to be sweeping even though the output frequency is not changing. If marker ramp does not change voltage and the front panel sweep LED is continuously on or off, then the instrument is not sweeping.

NOTE: In fast sweeps the sweep LED may appear to be on all the time, even though it is actually blinking.

NO SWEEP

1. Set the instrument to sweep continuously from 3 GHz to 4 GHz with a sweep time of 10 msec.
2. Check the voltage at the SWP TIME DAC test point, TP1. It should be +9.77 volts.
3. Press [**SINGLE**] SWEEP and then vary the sweep time from 10 to 99 msec, the voltage at this test point should go from +9.77 to +0.977 volts. Variations from these voltages by several tenths of a volt will affect the sweep time accuracy but not the assemblies ability to sweep.
4. Set the synthesizer to continuous sweep mode with a sweep time of 10 msec. Look at VGND, TP3, it should be at ground potential. Voltages greater than ± 50 mV indicates a problem.

If VGND is at zero volts but the instrument still is not sweeping, (Marker Ramp is not increasing in voltage):

- a. Check the output of the current shunt (U35B, pin 1). It should be +5 volts. If it is at -10 volts, then the sweep control logic is erroneously turning on the current shunt.
- b. Look at the voltage at MRK RMP, TP4. If it is at ground, then the reset amplifier 1 loop is probably closed and holding down the Marker Ramp. Check LRESET, U35A pin 2, to make sure that it is low.

Once the Marker Ramp is operating correctly, the instrument is sweeping, and if the output of the A58 sweep generator is not correct then follow the troubleshooting procedure for an incorrect sweep.

INCORRECT SWEEP

If the Marker Ramp waveform is correct, but the output of the sweep generator is still incorrect, then the various gain and attenuation stages must be checked:

1. Set the instrument to sweep from 2.3 GHz to 7 GHz.
 2. Check MKR RMP, TP4, for 0 to +10V ramp with a forward sweep time as indicated on the front panel.
 3. Measure RST RMP, TP2, for a 0 to -10V ramp with the correct sweep time. If this test point is stuck at ground:
 - a. Check U13 pin 14 in the reset amplifier 2 block. It should be a TTL high during the forward sweep of the ramp and low the rest of the time.
 - b. Look at the 20-30 SWP test point, TP8. It should be a ramp going from 0 to +9.4 volts. If it is not:
 - Place the synthesizer in the single sweep mode and press the following key sequence: **[SHIFT] [MHz] [2] [3] [Hz] [SHIFT] [kHz] [0] [Hz] [SINGLE]**. This will cause the marker ramp to sweep to +10 volts and stop.
 - Use Direct I/O addressing to write a 0 to channel 1 sub-channel 0 by pressing this key sequence:
 - [SHIFT] [GHz] [1] [Hz]**
 - [SHIFT] [MHz] [0] [Hz]**
 - [SHIFT] [KHz] [0] [Hz]**
- Check the digital input to U11 (pins 4-15), they should all be low. TP8 should be at ground.
- Now write a 4095 to the same strobe using the following key sequence: **[4] [0] [9] [5] [Hz]**. This should make all the digital inputs to U11 high. The voltage at TP8 should now be the opposite of the voltage at TP2. That is, since TP2 should be at approximately -10 volts, TP8 should be at about +10 volts.
 - Turn the front panel knob slowly and decreasing the number written to this strobe from 4095 to zero, the voltage at TP8 should go smoothly from +10 volts to ground. Press **[SHIFT] [MHz] [2] [3] [Hz] [SHIFT] [kHz] [0] [Hz]** to return the instrument to the normal operating mode.
4. Go to the continuous sweep mode and check to see that VSWP, TP10, is going from 0 to +9.4 volts. If not:
 - a. Check to see that the gates of Q7-Q12 (in the sweep width range attenuator) are at the correct voltage. See the circuit description block N for the appropriate values.

5. Finally, if the instrument does single band sweeps correctly but does not do multi-band sweeps, check U5:
 - a. Place the synthesizer in the single sweep mode, sweeping from 2.3 to 7 GHz.
 - b. Press **[SHIFT] [MHZ] [2] [3] [HZ] [SHIFT] [KHz] [0] [Hz]** (leveling) and **[SINGLE] SWEEP** to get the marker ramp to stop at +10 volts.
 - c. While measuring TP2, write 1023 to Reset DAC (U5) as follows:
[SHIFT] [GHz] [1] [Hz]
[SHIFT] [MHz] [2] [Hz]
[SHIFT] [KHz] [1] [0] [2] [3] [Hz]
 - d. This should cause the voltage at TP2 to go to zero. By turning the front panel knob slowly and decreasing the number from 1023 to 0, the voltage at TP2 should decrease smoothly from zero to -10 volts. With zero written to U5, all the digital inputs to U5 should be low. With 1023 written, all inputs should be high.

A58 Sweep Generator Component-Level Troubleshooting

Table A58-1. A58 Sweep Generator P1 Pin I/O (1 of 3)

Pin	Mnemonic	Levels	Source	Destination
1 56	GND PLANE 0V GND PLANE	INSTRUMENT GROUND 0V	*V INSTRUMENT GROUND	*V
2 57				
3 58				
4 59				
5 60				
6 61				
7 62				
8 63				
9 64				
10 65				
11 66				
12 67				
13 68	HSP LVSZ	TTL (HIGH TRUE) TTL (LOW TRUE)	XA57P1-13 E	*P XA54P1-9 F
14 69	LIPS LBX	TTL (LOW TRUE) TTL (LOW TRUE)	* *U	*NOT USED XA59P1-69 P
15 70	SIOA GND PLANE	TTL (LOW TRUE) 0V	XA60P1-15 INSTRUMENT GROUND	*NOT USED *V
16 71	SIOB GND PLANE	TTL (LOW TRUE) 0V	XA60P1-16 INSTRUMENT GROUND	*NOT USED *V
17 72	ADR0 HFILY0	TTL TTL (HIGH TRUE)	XA60P1-17 XA59P1-72	*NOT USED *NOT USED
18 73	ADR2 ADR1	TTL TTL	XA60P1-18 XA60P1-73	*NOT USED *NOT USED
19 74	ADR4 ADR3	TTL TTL	XA60P1-19 XA60 1-74	*NOT USED *NOT USED

A single letter in the source or destination column refers to a function block on this assembly schematic.

An asterisk (*) denotes multiple sources or destinations; refer to the A62 motherboard wiring list for a complete representation of signal sources and destinations.

A58 Sweep Generator Component-Level Troubleshooting

Table A58-1. A58 Sweep Generator P1 Pin I/O (2 of 3)

Pin	Mnemonic	Levels	Source	Destination
20 75	DB0 GND PLANE	TTL 0V	XA60P1-20 INSTRUMENT GROUND	*A B E *V
21 76	DB2 DB1	TTL TTL	XA60P1-21 XA60 1-76	*A B E *A B E
22 77	DB4 DB3	TTL TTL	XA60P1-22 XA60P1-77	*A B E *A B E
23 78	DB6 DB5	TTL TTL	XA60P1-23 XA60P1-78	*A B E *A B E
24 79	DB8 DB7	TTL TTL	XA60P1-24 XA60P1-79	*A B E *A B E
25 80	DB10 DB9	TTL TTL	XA60P1-25 XA60P1-80	*A E *A B E
26 81	DB12 DB11	TTL TTL	XA60P1-26 XA60P1-81	*A E *A E
27 82	DB14 DB13	TTL TTL	XA60P1-27 XA60P1-82	*A E *A E
28 83	WSPTM DB15	TTL (LOW TRUE) TTL	XA59P1-28 XA60P1-83	A *NOT USED
29 84	WRDAC WSPAT	TTL (LOW TRUE) TTL (LOW TRUE)	XA59P1-29 XA59P1-84	B S E
30 85	TYDKP LRSP	TTL (LOW TRUE) TTL (LOW TRUE)	XA59P1-100 XA59P1-85	*NOT USED P
31 86				
32 87				
33 88				
34 89	GND PLANE GND PLANE	0V 0V	INSTRUMENT GROUND INSTRUMENT GROUND	*V *V
35 90	+20V +20V	+20V +20V	XA52P1-16, 40 XA52P1-16, 40	*V *V
36 91	+5.2V +12V	+5.2V +12V	XA52P1-17, 18, 41, 42 XA52P1-9, 33	*V *NOT USED
37 92	+5.2V +5.2V	+5.2V +5.2V	XA52P1-17, 18, 41, 42 XA52P1-17, 18, 41, 42	*V *V

A single letter in the source or destination column refers to a function block on this assembly schematic.

An asterisk (*) denotes multiple sources or destinations; refer to the A62 motherboard wiring list for a complete representation of signal sources and destinations.

A58 Sweep Generator Component-Level Troubleshooting

Table A58-1. A58 Sweep Generator P1 Pin I/O (3 of 3)

Pin	Mnemonic	Levels	Source	Destination
38 93	-15V -5.2V	-15V -5.2V	XA56P1-15,30 XA53P1-18, 36	*V *NOT USED
39 94	-10V -10V	-10V -10V	XA53P1-12, 13, 31, 32 XA53P1-12, 13, 31, 32	*V *V
40 95	BVSWP	10V SWEEP	0	XA27P1-31
41 96	20/30 SWP MKR RMP	0V TO +10V 0 TO 10V SWEEP	M K	XA43P1-1 N XA57P1-96 R L
42 97	RGND VSWP	0V 0 TO 10V SWEEP	STAR GND POINT N	*V *F 0
43 98	RGND RGND	0V 0V	STAR GND POINT STAR GND POINT	*V *V
44 99	GND PLANE GND PLANE	0V 0V	INSTRUMENT GROUND INSTRUMENT GROUND	*V *V
45 100	GND PLANE LCHNG	0V TTL (LOW TRUE)	INSTRUMENT GROUND *	*V *NOT USED
46 101	GND PLANE GND PLANE	0V 0V	INSTRUMENT GROUND INSTRUMENT GROUND	*V *V
47 102	HFILYO	TTL (HIGH TRUE)	XA59P1-72	*NOT USED
48 102				
49 104				
50 105				
51 106				
52 107				
53 108	HXREF	TTL (HIGH TRUE)	A62J31-17	*NOT USED
54 109	*LSRQ	TTL (LOW TRUE)	*	*NOT USED
55 110	GND PLANE GND PLANE	0V 0V	INSTRUMENT GROUND INSTRUMENT GROUND	*V *V

A single letter in the source or destination column refers to a function block on this assembly schematic.

An asterisk (*) denotes multiple sources or destinations; refer to the A62 motherboard wiring list for a complete representation of signal sources and destinations.

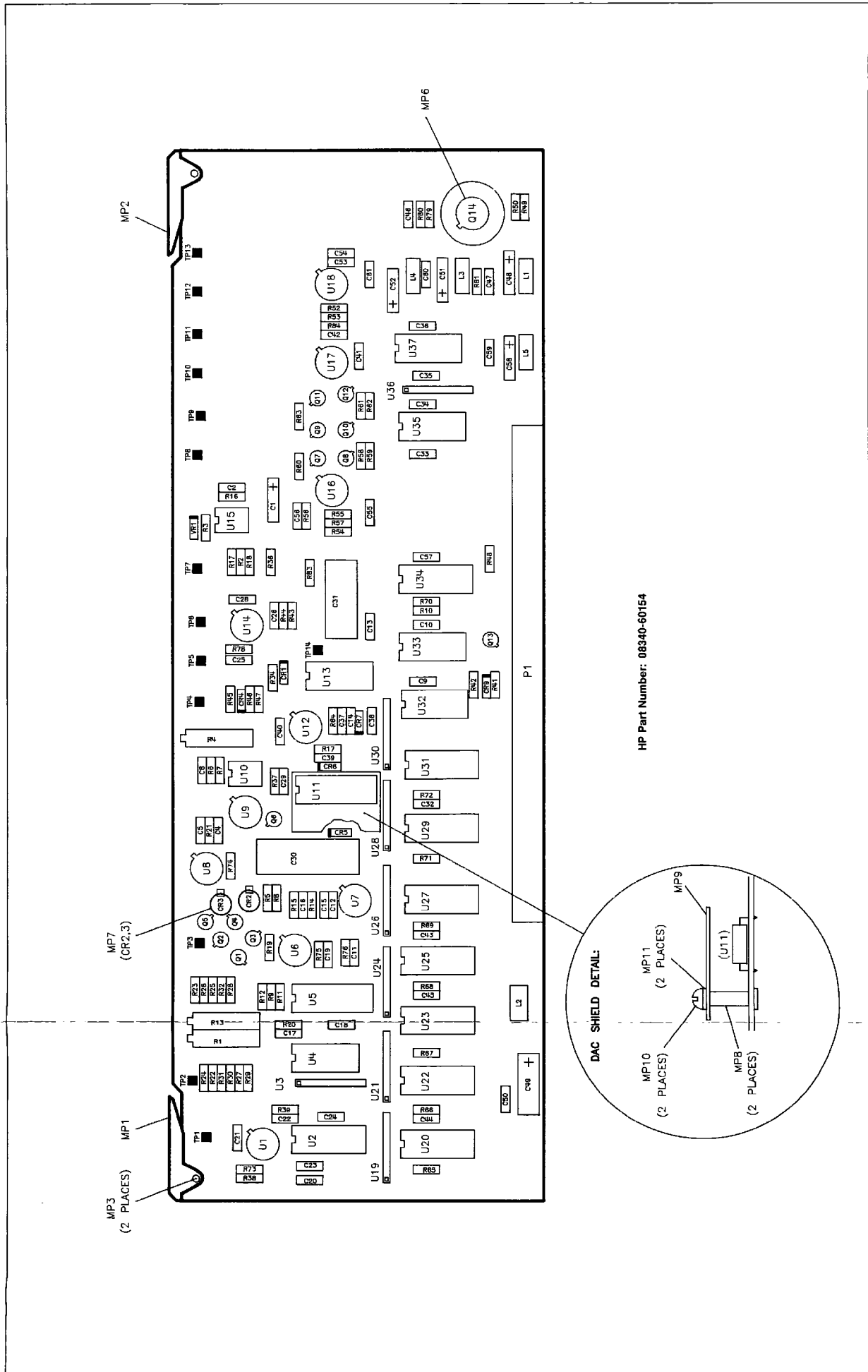

Figure A58-5. A58 Sweep Generator Component Location Diagram
 A58-20 Sweep Generator/YO Loop

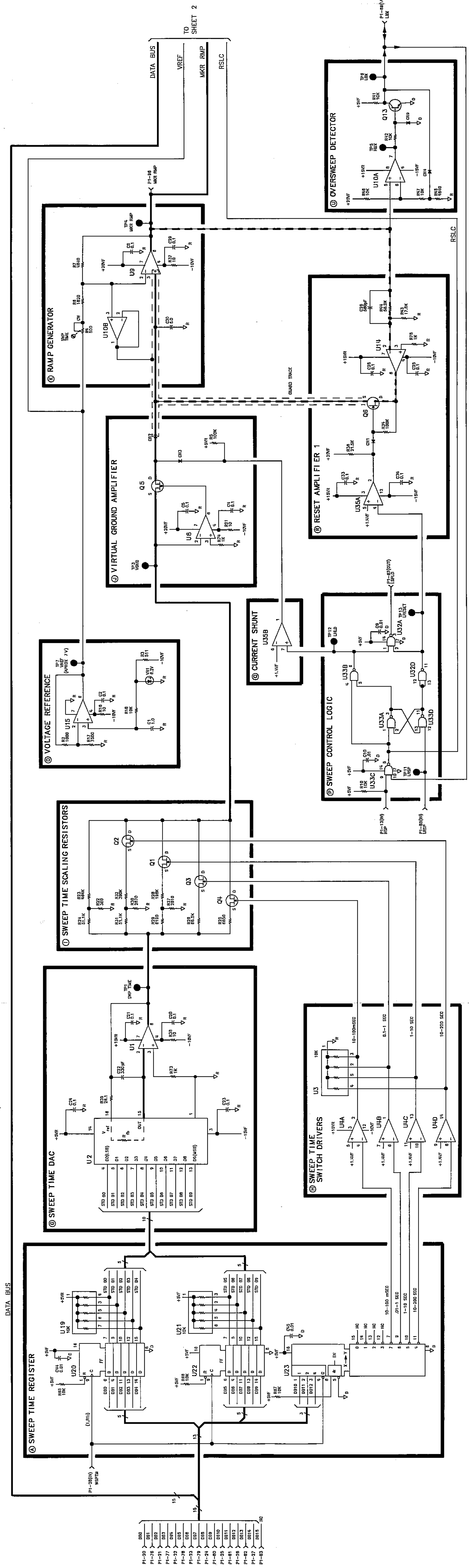

Figure A58-6. A58 Sweep Generator Schematic Diagram (1 of 2)
Sweep Generator/YO Loop
A58-21/A58-22

A58 Sweep Generator Component-Level Troubleshooting

Table A58-2. A58 Sweep Generator Replaceable Parts

Reference Designation	HP Part Number	C D	Qty	Description	Mfr Code	Mfr Part Number
A58	08340-60154	4	1	SWEEP GENERATOR	28480	08340-60154
A58C1	0180-0291	1	1	CAPACITOR-FXD .1UF ± 10% 35VDC TA	28480	0180-0291
A58C2	0160-4841	5	38	CAPACITOR-FXD .1UF +80-20% 50VDC CER	28480	0160-4841
A58C3				NOT ASSIGNED		
A58C4	0160-4841	5		CAPACITOR-FXD .1UF +80-20% 50VDC CER	28480	0160-4841
A58C5	0160-4841	5		CAPACITOR-FXD .1UF +80-20% 50VDC CER	28480	0160-4841
A58C6, 7				NOT ASSIGNED		
A58C8	0160-4841	5		CAPACITOR-FXD .1UF +80-20% 50VDC CER	28480	0160-4841
A58C9	0160-4832	4	8	CAPACITOR-FXD .01UF ± 10% 100VDC CER	28480	0160-4832
A58C10	0160-4832	4		CAPACITOR-FXD .01UF ± 10% 100VDC CER	28480	0160-4832
A58C11	0160-4841	5		CAPACITOR-FXD .1UF +80-20% 50VDC CER	28480	0160-4841
A58C12	0160-4841	5		CAPACITOR-FXD .1UF +80-20% 50VDC CER	28480	0160-4841
A58C13	0160-4841	5		CAPACITOR-FXD .1UF +80-20% 50VDC CER	28480	0160-4841
A58C14	0160-4841	5		CAPACITOR-FXD .1UF +80-20% 50VDC CER	28480	0160-4841
A58C15	0160-4841	5		CAPACITOR-FXD .1UF +80-20% 50VDC CER	28480	0160-4841
A58C16	0160-4841	5		CAPACITOR-FXD .1UF +80-20% 50VDC CER	28480	0160-4841
A58C17	0160-4841	5		CAPACITOR-FXD .1UF +80-20% 50VDC CER	28480	0160-4841
A58C18	0160-4841	5		CAPACITOR-FXD .1UF +80-20% 50VDC CER	28480	0160-4841
A58C19	0160-4832	4		CAPACITOR-FXD .01UF ± 10% 100VDC CER	28480	0160-4832
A58C20	0160-4841	5		CAPACITOR-FXD .1UF +80-20% 50VDC CER	28480	0160-4841
A58C21	0160-4841	5		CAPACITOR-FXD .1UF +80-20% 50VDC CER	28480	0160-4841
A58C22	0160-4810	8	1	CAPACITOR-FXD 330PF ± 5% 100VDC CER	28480	0160-4810
A58C23	0160-4841	5		CAPACITOR-FXD .1UF +80-20% 50VDC CER	28480	0160-4841
A58C24	0160-4841	5		CAPACITOR-FXD .1UF +80-20% 50VDC CER	28480	0160-4841
A58C25	0160-4841	5		CAPACITOR-FXD .1UF +80-20% 50VDC CER	28480	0160-4841
A58C26	0160-4825	5	1	CAPACITOR-FXD 560PF ± 5% 100VDC CER	28480	0160-4825
A58C27				NOT ASSIGNED		
A58C28	0160-4841	5		CAPACITOR-FXD .1UF +80-20% 50VDC CER	28480	0160-4841
A58C29	0160-4841	5		CAPACITOR-FXD .1UF +80-20% 50VDC CER	28480	0160-4841
A58C30	0160-5662	0	1	CAPACITOR-FXD 5UF ± 10% 50VDC NET-POLYC	28480	0160-5662
A58C31	0160-4265	7	1	CAPACITOR-FXD .47UF ± 20% 50VDC	84411	HEW 386
A58C32	0160-4832	4		CAPACITOR-FXD .01UF ± 10% 100VDC CER	28480	0160-4832
A58C33	0160-4841	5		CAPACITOR-FXD .1UF +80-20% 50VDC CER	28480	0160-4841
A58C34	0160-4841	5		CAPACITOR-FXD .1UF +80-20% 50VDC CER	28480	0160-4841
A58C35	0160-4841	5		CAPACITOR-FXD .1UF +80-20% 50VDC CER	28480	0160-4841
A58C36	0160-4841	5		CAPACITOR-FXD .1UF +80-20% 50VDC CER	28480	0160-4841
A58C37	0160-4841	5		CAPACITOR-FXD .1UF +80-20% 50VDC CER	28480	0160-4841
A58C38	0160-4841	5		CAPACITOR-FXD .1UF +80-20% 50VDC CER	28480	0160-4841
A58C39	0160-4807	3	1	CAPACITOR-FXD 33PF ± 5% 100VDC CER 0 ± 30	28480	0160-4807
A58C40	0160-4841	5		CAPACITOR-FXD .1UF +80-20% 50VDC CER	28480	0160-4841
A58C41	0160-4841	5		CAPACITOR-FXD .1UF +80-20% 50VDC CER	28480	0160-4841
A58C42	0160-4841	5		CAPACITOR-FXD .1UF +80-20% 50VDC CER	28480	0160-4841
A58C43	0160-4832	4		CAPACITOR-FXD .01UF ± 10% 100VDC CER	28480	0160-4832
A58C44	0160-4832	4		CAPACITOR-FXD .01UF ± 10% 100VDC CER	28480	0160-4832
A58C45	0160-4832	4		CAPACITOR-FXD .01UF ± 10% 100VDC CER	28480	0160-4832
A58C46	0160-4841	5		CAPACITOR-FXD .1UF +80-20% 50VDC CER	28480	0160-4841
A58C47	0160-4841	5		CAPACITOR-FXD .1UF +80-20% 50VDC CER	28480	0160-4841
A58C48	0180-1731	8	1	CAPACITOR-FXD 4.7UF ± 10% 50VDC TA	28480	0180-1731
A58C49	0180-0374	3	1	CAPACITOR-FXD 10UF ± 10% 20VDC TA	56289	150D106X9020B2
A58C50	0160-4841	5		CAPACITOR-FXD .1UF +80-20% 50VDC CER	28480	0160-4841
A58C51	0180-0116	1	3	CAPACITOR-FXD 6.8UF ± 10% 35VDC TA	28480	0180-0116
A58C52	0180-0116	1		CAPACITOR-FXD 6.8UF ± 10% 35VDC TA	28480	0180-0116
A58C53	0160-4841	5		CAPACITOR-FXD .1UF +80-20% 50VDC CER	28480	0160-4841
A58C54	0160-4841	5		CAPACITOR-FXD .1UF +80-20% 50VDC CER	28480	0160-4841
A58C55	0160-4841	5		CAPACITOR-FXD .1UF +80-20% 50VDC CER	28480	0160-4841
A58C56	0160-4841	5		CAPACITOR-FXD .1UF +80-20% 50VDC CER	28480	0160-4841
A58C57	0160-4832	4		CAPACITOR-FXD .01UF ± 10% 100VDC CER	28480	0160-4832
A58C58	0180-0116	1		CAPACITOR-FXD 6.8UF ± 10% 35VDC TA	28480	0180-0116
A58C59	0160-4841	5		CAPACITOR-FXD .1UF +80-20% 50VDC CER	28480	0160-4841
A58C60	0160-4841	5		CAPACITOR-FXD .1UF +80-20% 50VDC CER	28480	0160-4841
A58C61	0160-4841	5		CAPACITOR-FXD .1UF +80-20% 50VDC CER	28480	0160-4841
A58CR1	1901-1098	1	2	DIODE-SWITCHING 1N4150 50V 200MA 4NS	9N171	1N4150
A58CR2	1901-0586	0	9	DIODE-GEN PRP 30V 25MA TO-72	28480	1901-0586
A58CR3	1901-0586	0		DIODE-GEN PRP 30V 25MA TO-72	28480	1901-0586
A58CR4	1901-1098	1		DIODE-SWITCHING 1N4150 50V 200MA 4NS	9N171	1N4150
A58CR5	1901-0518	8	2	DIODE-SM SIG SCHOTTKY	28480	1901-0518

A58 Sweep Generator Component-Level Troubleshooting

Table A58-2. A58 Sweep Generator Replaceable Parts

Reference Designation	HP Part Number	C	D	Qty	Description	Mfr Code	Mfr Part Number
A58CR6	1901-0518	8			DIODE-SM SIG SCHOTTKY	28480	1901-0518
A58CR7	1901-0033	2	2		DIODE-GEN PRP 180V 200MA DO-7	28480	1901-0033
A58CR8					NOT ASSIGNED		
A58CR9	1901-0033	2			DIODE-GEN PRP 180V 200MA DO-7	28480	1901-0033
A58L1	9140-0210	1	4		INDUCTOR RF-CH-MLD 100UH 5% .166DX.385LG	28480	9140-0210
A58L2	9100-0539	3	1		INDUCTOR RF-CH-MLD 100UH 5% .156DX.375LG	28480	9100-0539
A58L3	9140-0210	1			INDUCTOR RF-CH-MLD 100UH 5% .166DX.385LG	28480	9140-0210
A58L4	9140-0210	1			INDUCTOR RF-CH-MLD 100UH 5% .166DX.385LG	28480	9140-0210
A58L5	9140-0210	1			INDUCTOR RF-CH-MLD 100UH 5% .166DX.385LG	28480	9140-0210
A58MP1	4040-0753	0	1		EXTR-PC BD GRN POLYC 062-8D-THKNS	28480	4040-0753
A58MP2	4040-0747	2	1		EXTR-PC BD GRA POLYC 062-8D-THKNS	28480	4040-0747
A58MP3	1480-0073	6	2		PIN-ROLL .062-IN-DIA .25-IN-LG BE-CU	28480	1480-0073
A58MP4,5					NOT ASSIGNED		
A58MP6	1205-0011	0	1		HEAT SINK TO-5/TO-39-CS	28480	1205-0011
A58MP7	1200-0172	4	2		INSULATOR-XSTR DAP-GL	28480	1200-0172
A58MP8	0380-1221	5	1		STANDOFF-RUT-ON .25-IN-LG 2-56 THD	28480	0380-1221
A58MP9	08340-00068	3	1		DAC SHIELD	28480	08340-00068
A58MP10	0520-0126	5	1		SCREW-MACH 2-56 125-IN-LG 100DEG	28480	0520-0126
A58MP11	2190-0112	0	1		WASHER LK .088-IN-DIA	28480	2190-0112
A58P1	1251-7469	3	1		CONN - POST TYPE	28480	1251-7469
A58Q1	1855-0420	2	10		TRANSISTOR J-FET 2N4391 N-CHAN D-MODE	01295	2N4391
A58Q2	1855-0420	2			TRANSISTOR J-FET 2N4391 N-CHAN D-MODE	01295	2N4391
A58Q3	1855-0420	2			TRANSISTOR J-FET 2N4391 N-CHAN D-MODE	01295	2N4391
A58Q4	1855-0420	2			TRANSISTOR J-FET 2N4391 N-CHAN D-MODE	01295	2N4391
A58Q5	1855-0278	8	1		TRANSISTOR J-FET 2N5116 P-CHAN D-MODE	17856	2N5116
A58Q6	1855-0388	2			TRANSISTOR J-FET 2N4392 N-CHAN D-MODE	04713	2N4392
A58Q7	1855-0420	2			TRANSISTOR J-FET 2N4391 N-CHAN D-MODE	01295	2N4391
A58Q8	1855-0420	2			TRANSISTOR J-FET 2N4391 N-CHAN D-MODE	01295	2N4391
A58Q9	1855-0420	2			TRANSISTOR J-FET 2N4391 N-CHAN D-MODE	01295	2N4391
A58Q10	1855-0420	2			TRANSISTOR J-FET 2N4391 N-CHAN D-MODE	01295	2N4391
A58Q11	1855-0420	2			TRANSISTOR J-FET 2N4391 N-CHAN D-MODE	01295	2N4391
A58Q12	1855-0420	2			TRANSISTOR J-FET 2N4391 N-CHAN D-MODE	01295	2N4391
A58Q13	1854-0404	0	1		TRANSISTOR NPN SI TO-18 PD=360MW	28480	1854-0404
A58Q14	1854-0361	8	1		TRANSISTOR NPN 2N4239 SI TO-5 PD=6W	02037	2N4239
A58R1	2100-3154	7	1		RESISTOR-TRMR 1K 10% C SIDE-ADJ 17-TRN	02111	43P102
A58R2	0757-0280	3	9		RESISTOR 1K 1% .125W F TC=0±100	24546	C4-1/8-T0-1001-F
A58R3	0757-0416	7	2		RESISTOR 511 1% .125W F TC=0±100	24546	C4-1/8-T0-511R-F
A58R4	2100-3123	0	1		RESISTOR-TRMR 500 10% C SIDE-ADJ 17-TRN	02111	43P501
A58R5	0757-0465	6	3		RESISTOR 100K 1% .125W F TC=0±100	24546	C4-1/8-T0-1003-F
A58R6	0757-0428	1	1		RESISTOR 1.62K 1% .125W F TC=0±100	24546	C4-1/8-T0-1621-F
A58R7	0698-3155	1	2		RESISTOR 4.64K 1% .125W F TC=0±100	24546	C4-1/8-T0-4641-F
A58R8	0757-0401	0	3		RESISTOR 100 1% .125W F TC=0±100	24546	C4-1/8-T0-101F
A58R9	0699-0747	3	2		RESISTOR 4K .05% 1W F TC=0±10	28480	0699-0747
A58R10	0757-0442	9	14		RESISTOR 10K 1% .125W F TC=0±100	24546	C4-1/8-T0-1002-F
A58R11	0698-8960	6	1		RESISTOR 750K 1% .125W F TC=0±100	28480	0698-8960
A58R12	0699-0747	3			RESISTOR 4K .05% 1W F TC=0±10	28480	0699-0747
A58R13	2100-3095	5	1		RESISTOR-TRMR 200 10% C SIDE-ADJ 17-TRN	02111	43P201
A58R14	0757-0346	2	9		RESISTOR 10 1% .125W F TC=0±100	24546	C4-1/8-T0-10R0-F
A58R15	0757-0346	2			RESISTOR 10 1% .125W F TC=0±100	24546	C4-1/8-T0-10R0-F
A58R16	0757-0346	2			RESISTOR 10 1% .125W F TC=0±100	24546	C4-1/8-T0-10R0-F
A58R17	0757-0440	7	1		RESISTOR 7.5K 1% .125W F TC=0±100	24546	C4-1/8-T0-7501-F
A58R18	0757-0442	9			RESISTOR 10K 1% .125W F TC=0±100	24546	C4-1/8-T0-1002-F
A58R19	0757-0200	7	1		RESISTOR 5.62K 1% .125W F TC=0±100	24546	C4-1/8-T0-5621-F
A58R20	0757-0438	3	2		RESISTOR 5.11K 1% .125W F TC=0±100	24546	C4-1/8-T0-5111-F
A58R21	0757-0346	2			RESISTOR 10 1% .125W F TC=0±100	24546	C4-1/8-T0-10R0-F
A58R22	0757-1101	9	1		RESISTOR 360 1% .125W F TC=0±100	24546	C4-1/8-T0-361-F
A58R23	0698-3260	9	1		RESISTOR 464K 1% .125W F TC=0±100	28480	0698-3260
A58R24	0757-0458	7	2		RESISTOR 51.1K 1% .125W F TC=0±100	24546	C4-1/8-T0-5112-F
A58R25	0698-3484	9	1		RESISTOR 6.65K 1% .125W F TC=0±100	24546	C4-1/8-T0-6651-F
A58R26	0698-4503	5	1		RESISTOR 66.5K 1% .125W F TC=0±100	24546	C4-1/8-T0-6652-F
A58R27	0698-0085	0	1		RESISTOR 2.61K 1% .125W F TC=0±100	24546	C4-1/8-T0-2611-F
A58R28	0698-3453	2	1		RESISTOR 196K 1% .125W F TC=0±100	24546	C4-1/8-T0-1963-F
A58R29	0757-0290	5	1		RESISTOR 6.19K 1% .125W F TC=0±100	19701	MFAC1/8-T0-6191-F
A58R30	0698-3151	7	1		RESISTOR 2.87K 1% .125W F TC=0±100	24546	C4-1/8-T0-2871-F

A58 Sweep Generator Component-Level Troubleshooting

Table A58-2. A58 Sweep Generator Replaceable Parts

Reference Designation	HP Part Number	C D	Qty	Description	Mfr Code	Mfr Part Number
A58R31	0757-0458	7		RESISTOR 51.1K 1% .125W F TC=0±100	24546	C4-1/8-T0-5112-F
A58R32	0698-5093	0	1	RESISTOR 390K 1% .125W F TC=0±100	28480	0698-5093
A58R33				NOT ASSIGNED		
A58R34	0757-0465	6		RESISTOR 100K 1% .125W F TC=0±100	24546	C4-1/8-T0-1003-F
A58R35				NOT ASSIGNED		
A58R36	0757-0199	3	1	RESISTOR 21.5K 1% .125W F TC=0±100	24546	C4-1/8-T0-2152-F
A58R37	0757-0348	2		RESISTOR 10 1% .125W F TC=0±100	24546	C4-1/8-T0-10R0-F
A58R38	0757-0346	2		RESISTOR 10 1% .125W F TC=0±100	24546	C4-1/8-T0-10R0-F
A58R39	0698-3432	7	1	RESISTOR 26.1 1% .125W F TC=0±100	03888	PME55-1/8-T0-26R1-F
A58R40				NOT ASSIGNED		
A58R41	0757-0442	9		RESISTOR 10K 1% .125W F TC=0±100	24546	C4-1/8-T0-1002-F
A58R42	0757-0442	9		RESISTOR 10K 1% .125W F TC=0±100	24546	C4-1/8-T0-1002-F
A58R43	0698-3138	8	1	RESISTOR 17.8K 1% .125W F TC=0±100	24546	C4-1/8-T0-1782-F
A58R44	0757-0459	8	1	RESISTOR 56.2K 1% .125W F TC=0±100	24546	C4-1/8-T0-5622-F
A58R45	0698-3155	1		RESISTOR 4.64K 1% .125W F TC=0±100	24546	C4-1/8-T0-4641-F
A58R46	0757-0442	9		RESISTOR 10K 1% .125W F TC=0±100	24546	C4-1/8-T0-1002-F
A58R47	0757-0442	9		RESISTOR 10K 1% .125W F TC=0±100	24546	C4-1/8-T0-1002-F
A58R48	0698-3430	5	1	RESISTOR 21.5 1% .125W F TC=0±100	03888	PME55-1/8-T0-21R5-F
A58R49	0757-0289	2	1	RESISTOR 13.3K 1% .125W F TC=0±100	19701	MF4C1/8-T0-1332-F
A58R50	0757-0280	3		RESISTOR 1K 1% .125W F TC=0±100	24546	C4-1/8-T0-1001-F
A58R51				NOT ASSIGNED		
A58R52	0699-0683	6	3	RESISTOR 10K 01% .1W F TC=0±15	28480	0699-0683
A58R53	0699-0683	6		RESISTOR 10K 01% .1W F TC=0±15	28480	0699-0683
A58R54	0757-0346	2		RESISTOR 10 1% .125W F TC=0±100	24546	C4-1/8-T0-10R0-F
A58R55	0699-0683	6		RESISTOR 10K 01% .1W F TC=0±15	28480	0699-0683
A58R56	0757-0346	2		RESISTOR 10 1% .125W F TC=0±100	24546	C4-1/8-T0-10R0-F
A58R57	0699-0685	8	1	RESISTOR 2K 01% .1W F TC=0±15	28480	0699-0685
A58R58	0699-0684	7	2	RESISTOR 8.1K 01% .1W F TC=0±15	28480	0699-0684
A58R59	0699-0275	2	1	RESISTOR 1K 01% .1W F TC=0±15	28480	0699-0275
A58R60	0757-0465	6		RESISTOR 100K 1% .125W F TC=0±100	24546	C4-1/8-T0-1003-F
A58R61	0699-0684	7		RESISTOR 8.1K 01% .1W F TC=0±15	28480	0699-0684
A58R62	0699-0682	5	1	RESISTOR 900 01% .1W F TC=0±15	28480	0699-0682
A58R63	0757-0401	0		RESISTOR 100 1% .125W F TC=0±100	24546	C4-1/8-T0-101-F
A58R64	0757-0346	2		RESISTOR 10 1% .125W F TC=0±100	24546	C4-1/8-T0-10R0-F
A58R65	0757-0442	9		RESISTOR 10K 1% .125W F TC=0±100	24546	C4-1/8-T0-1002-F
A58R66	0757-0442	9		RESISTOR 10K 1% .125W F TC=0±100	24546	C4-1/8-T0-1002-F
A58R67	0757-0442	9		RESISTOR 10K 1% .125W F TC=0±100	24546	C4-1/8-T0-1002-F
A58R68	0757-0442	9		RESISTOR 10K 1% .125W F TC=0±100	24546	C4-1/8-T0-1002-F
A58R69	0757-0442	9		RESISTOR 10K 1% .125W F TC=0±100	24546	C4-1/8-T0-1002-F
A58R70	0757-0442	9		RESISTOR 10K 1% .125W F TC=0±100	24546	C4-1/8-T0-1002-F
A58R71	0757-0442	9		RESISTOR 10K 1% .125W F TC=0±100	24546	C4-1/8-T0-1002-F
A58R72	0757-0442	9		RESISTOR 10K 1% .125W F TC=0±100	24546	C4-1/8-T0-1002-F
A58R73	0757-0280	3		RESISTOR 1K 1% .125W F TC=0±100	24546	C4-1/8-T0-1001-F
A58R74	0757-0280	3		RESISTOR 1K 1% .125W F TC=0±100	24546	C4-1/8-T0-1001-F
A58R75	0757-0280	3		RESISTOR 1K 1% .125W F TC=0±100	24546	C4-1/8-T0-1001-F
A58R76	0757-0280	3		RESISTOR 1K 1% .125W F TC=0±100	24546	C4-1/8-T0-1001-F
A58R77	0757-0280	3		RESISTOR 1K 1% .125W F TC=0±100	24546	C4-1/8-T0-1001-F
A58R78	0757-0280	3		RESISTOR 1K 1% .125W F TC=0±100	24546	C4-1/8-T0-1001-F
A58R79	0757-0416	7	1	RESISTOR 511 1% .125W F TC=0±100	24546	C4-1/8-T0-511R-F
A58R80	0757-0278	9	1	RESISTOR 1.78K 1% .125W F TC=0±100	24546	C4-1/8-T0-1781-F
A58R81	0757-0438	3		RESISTOR 5.11K 1% .125W F TC=0±100	24546	C4-1/8-T0-5111-F
A58R82				NOT ASSIGNED		
A58R83	0757-0401	0		RESISTOR 100 1% .125W F TC=0±100	24546	C4-1/8-T0-101-F
A58R84	0757-0280	3		RESISTOR 1K 1% .125W F TC=0±100	24546	C4-1/8-T0-1001-F
A58TP1	0360-0535	0	14	TERMINAL TEST POINT PCB	00000	ORDER BY DESCRIPTION
A58TP2	0360-0535	0		TERMINAL TEST POINT PCB	00000	ORDER BY DESCRIPTION
A58TP3	0360-0535	0		TERMINAL TEST POINT PCB	00000	ORDER BY DESCRIPTION
A58TP4	0360-0535	0		TERMINAL TEST POINT PCB	00000	ORDER BY DESCRIPTION
A58TP5	0360-0535	0		TERMINAL TEST POINT PCB	00000	ORDER BY DESCRIPTION
A58TP6	0360-0535	0		TERMINAL TEST POINT PCB	00000	ORDER BY DESCRIPTION
A58TP7	0360-0535	0		TERMINAL TEST POINT PCB	00000	ORDER BY DESCRIPTION
A58TP8	0360-0535	0		TERMINAL TEST POINT PCB	00000	ORDER BY DESCRIPTION
A58TP9	0360-0535	0		TERMINAL TEST POINT PCB	00000	ORDER BY DESCRIPTION
A58TP10	0360-0535	0		TERMINAL TEST POINT PCB	00000	ORDER BY DESCRIPTION
A58TP11	0360-0535	0		TERMINAL TEST POINT PCB	00000	ORDER BY DESCRIPTION
A58TP12	0360-0535	0		TERMINAL TEST POINT PCB	00000	ORDER BY DESCRIPTION
A58TP13	0360-0535	0		TERMINAL TEST POINT PCB	00000	ORDER BY DESCRIPTION
A58TP14	0360-0535	0		TERMINAL TEST POINT PCB	00000	ORDER BY DESCRIPTION

A58 Sweep Generator Component-Level Troubleshooting

Table A58-2. A58 Sweep Generator Replaceable Parts

Reference Designation	HP Part Number	C D	Qty	Description	Mfr Code	Mfr Part Number
A58U1	1826-0471	2	9	IC OP AMP LOW-DRIFT TO-99 PKG	28480	1826-0471
A58U2	1820-1984	2	1	IC CONV 10-B-D/A 16-DIP-C PKG	24355	AD581KD
A58U3	1810-0206	8	7	NETWORK-RES 8-SIP10 0K OHM X 7	01121	208A103
A58U4	1826-0138	8	3	IC COMPARATOR GP QUAD 14-DIP-P PKG	01295	LM339N
A58U5	1826-0938	6	1	D/A 10-bit 18-CERDIP BPLR	28480	1826-0938
A58U6	1826-0471	2		IC OP AMP LOW-DRIFT TO-99 PKG	28480	1826-0471
A58U7	1826-0471	2		IC OP AMP LOW-DRIFT TO-99 PKG	28480	1826-0471
A58U8	1826-0471	2		IC OP AMP LOW-DRIFT TO-99 PKG	28480	1826-0471
A58U9	1813-0041	5	1	IC OP AMP TO-99 PKG	27014	LH0042CH
A58U10	1826-0785	1	1	IC OP AMP LOW-BIAS-H-IMPED DUAL 8-DIP-C	01295	TL072ACJG
A58U11	1826-0684	9	1	IC CONV 12-B-D/A 18 DIP-C PKG	28480	1826-0684
A58U12	1826-0471	2		IC OP AMP LOW-DRIFT TO-99 PKG	28480	1826-0471
A58U13	1826-1140	4	1	IC SMP/L/HOLD 14 CERDIP	02180	SMP-10FT
A58U14	1826-0471	2		IC OP AMP LOW-DRIFT TO-99 PKG	28480	1826-0471
A58U15	1826-0783	9	1	IC OP AMP LOW-NOIS 8-DIP-C PKG	52063	XR5534ACN
A58U16	1826-0471	2		IC OP AMP LOW-DRIFT TO-99 PKG	28480	1826-0471
A58U17	1826-0471	2		IC OP AMP LOW-DRIFT TO-99 PKG	28480	1826-0471
A58U18	1826-0471	2		IC OP AMP LOW-DRIFT TO-99 PKG	28480	1826-0471
A58U19	1810-0206	8		NETWORK-RES 8-SIP10 0K OHM X 7	01121	208A103
A58U20	1820-1196	8	6	IC FF TTL LS D-TYPE POS-EDGE-TRIG COM	01295	SN74LS174N
A58U21	1810-0206	8		NETWORK-RES 8-SIP10 0K OHM X 7	01121	208A103
A58U22	1820-1196	8		IC FF TTL LS D-TYPE POS-EDGE-TRIG COM	01295	SN74LS174N
A58U23	1820-2550	0	2	IC DCDR TTL LS 3-TO-8-LINE	01295	SN74LS137N
A58U24	1810-0206	8		NETWORK-RES 8-SIP10 0K OHM X 7	01121	208A103
A58U25	1820-1196	8		IC FF TTL LS D-TYPE POS-EDGE-TRIG COM	01295	SN74LS174N
A58U26	1810-0206	8		NETWORK-RES 8-SIP10 0K OHM X 7	01121	208A103
A58U27	1820-1196	8		IC FF TTL LS D-TYPE POS-EDGE-TRIG COM	01295	SN74LS174N
A58U28	1810-0206	8		NETWORK-RES 8-SIP10 0K OHM X 7	01121	208A103
A58U29	1820-1196	8		IC FF TTL LS D-TYPE POS-EDGE-TRIG COM	01295	SN74LS174N
A58U30	1810-0206	8		NETWORK-RES 8-SIP10 0K OHM X 7	01121	208A103
A58U31	1820-1196	8		IC FF TTL LS D-TYPE POS-EDGE-TRIG COM	01295	SN74LS174N
A58U32	1820-1197	9	1	IC GATE TTL LS NAND QUAD 2-INP	01295	SN74LS00N
A58U33	1820-1425	6	1	IC SCHMITT-TRIG TTL LS NAND QUAD 2-INP	01295	SN74LS132N
A58U34	1820-2550	0		IC DCDR TTL LS 3-TO-8-LINE	01295	SN74LS137N
A58U35	1826-0138	8		IC COMPARATOR GP QUAD 14-DIP-P PKG	01295	LM339N
A58U36	1810-0371	8	1	NETWORK-RES 8-SIP100 0K OHM X7	01121	208A104
A58U37	1826-0138	8		IC COMPARATOR GP QUAD 14-DIP-P PKG	01295	LM339N
A58VR1	1902-0625	0	1	DIODE-ZNR 1N829 6.2V 5% DO-7 PD = 25W	04713	1N829

A58 Sweep Generator Component-Level Troubleshooting

Reference Designation	HP Part Number	C D	Qty	Description	Mfr Code	Mfr Part Number
YO LOOP SECTION ATTACHING HARDWARE						
1	0360-0452	0	2	TERMINAL-SLDR LUG PL-MTG FOR-#10-SCR	28480	0360-0452
2	0520-0164	1	2	SCREW-MACH 2-56 25-IN-LG 82 DEG	00000	ORDER BY DESCRIPTION
3	1250-0258	2	2	A49J1,J2 CONNECTOR-RF MALE SMB	28480	1250-0258
4	1250-0691	7	4	A49J3,J4 A48J1,2- CONNECTOR-RF MALE SMB	28480	1250-0691
5	2190-0124	4	2	WASHER-LK INTL T NO. 10 195-IN-ID	28480	2190-0124
6	2200-0103	2	13	SCREW-MACH 4-40 25-IN-LG PAN-HD-POZI	00000	ORDER BY DESCRIPTION
7	2200-0147	4	2	SCREW-MACH 4-40 5-IN-LG PAN-HD-POZI	00000	ORDER BY DESCRIPTION
8	2200-0165	6	23	SCREW-MACH 4-40 25-IN-LG 82 DEG	00000	ORDER BY DESCRIPTION
9	2360-0331	6	4	SCREW-MACH 6-32 25-IN-LG PANHD POZI	28480	2360-0331
10	2360-0333	8	2	SCREW-MACH-6-32 25-IN-LG 100 DEG	28480	2360-0333
11	2950-0078	9	2	NUT-HEX-DBL-CHAM 10-32-THD 067-IN-THK	28480	2950-0078
12	3050-0105	6	2	WASHER-FL MTLG NO. 4 125-IN-ID	28480	3050-0105
13	3050-0907	6	4	WASHER-SHLDR NO. 10 194-IN-ID	28480	3050-0907
14	08340-00075	2	1	DECK-YO LOOP	28480	08340-00075
15	08340-00049	0	1	COVER-SAMPLER	28480	08340-00049
16	08340-00050	3	1	COVER-PHASE LOCK	28480	08340-00050
17	08340-20204	1	1	HOUSING-YT P/L	28480	08340-20204
18	85660-20088	8	2	STUD-YTO LOOP	28480	85660-20088
19	85660-20100	5	2	EXTRACTOR	28480	85660-20100
20	86701-00054	8	1	SPACER-SAMPLER	28480	86701-00054
21	2190-0003	8	2	WASHER-LK HLCL NO. 4 115-IN-ID	28480	2190-0003
22	1250-1142	5	1	WASHER-LK INTL T 1/2 IN 26-IN-ID	28480	1250-1142
23	1250-1143	6	1	NUT-RF CONNECTOR-SERIES SM A	28480	1250-1143

Figure. A58-7. YO Loop Section Attaching Hardware (1 of 4)

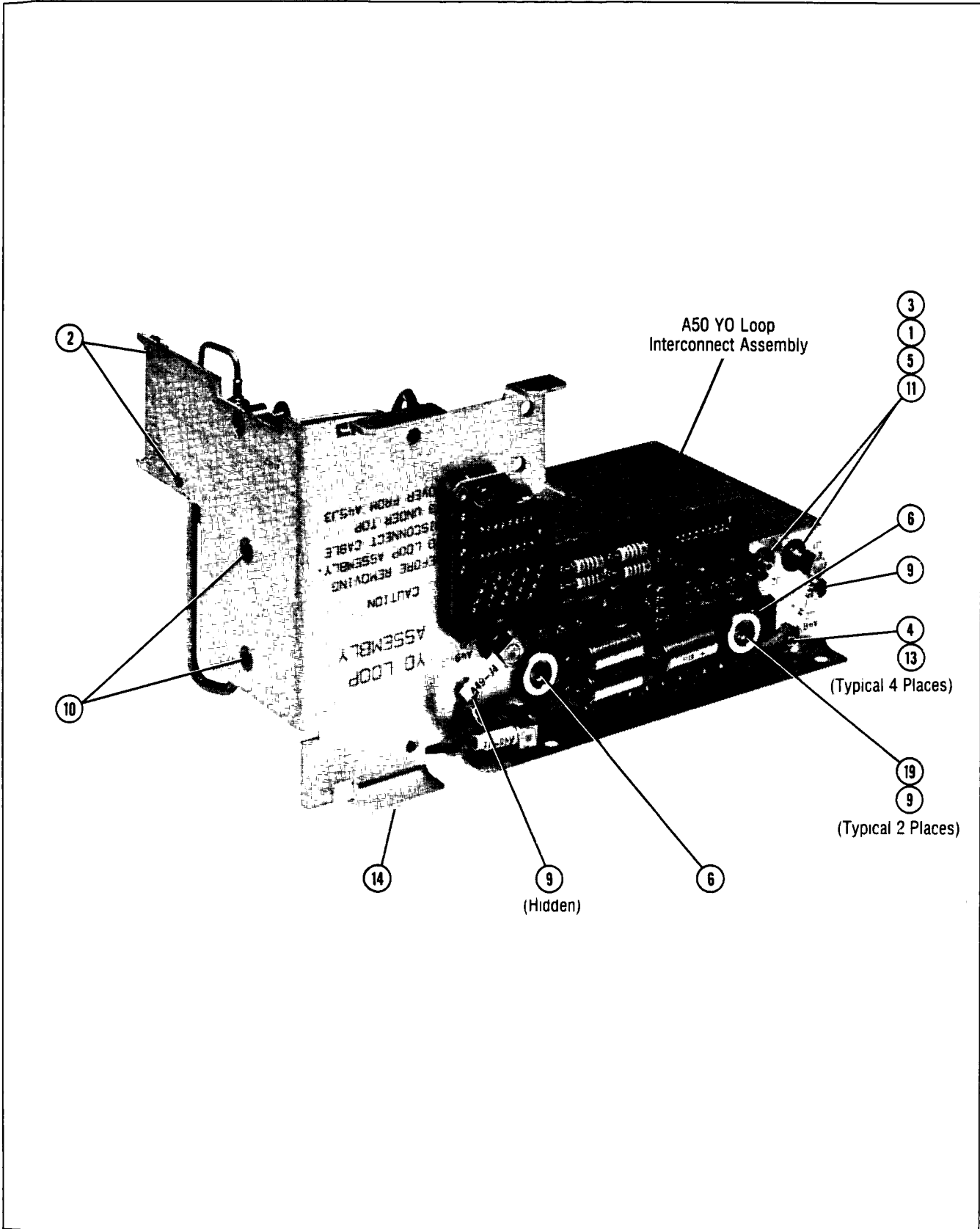

Figure A58-7. YO Loop Section Attaching Hardware (2 of 4)

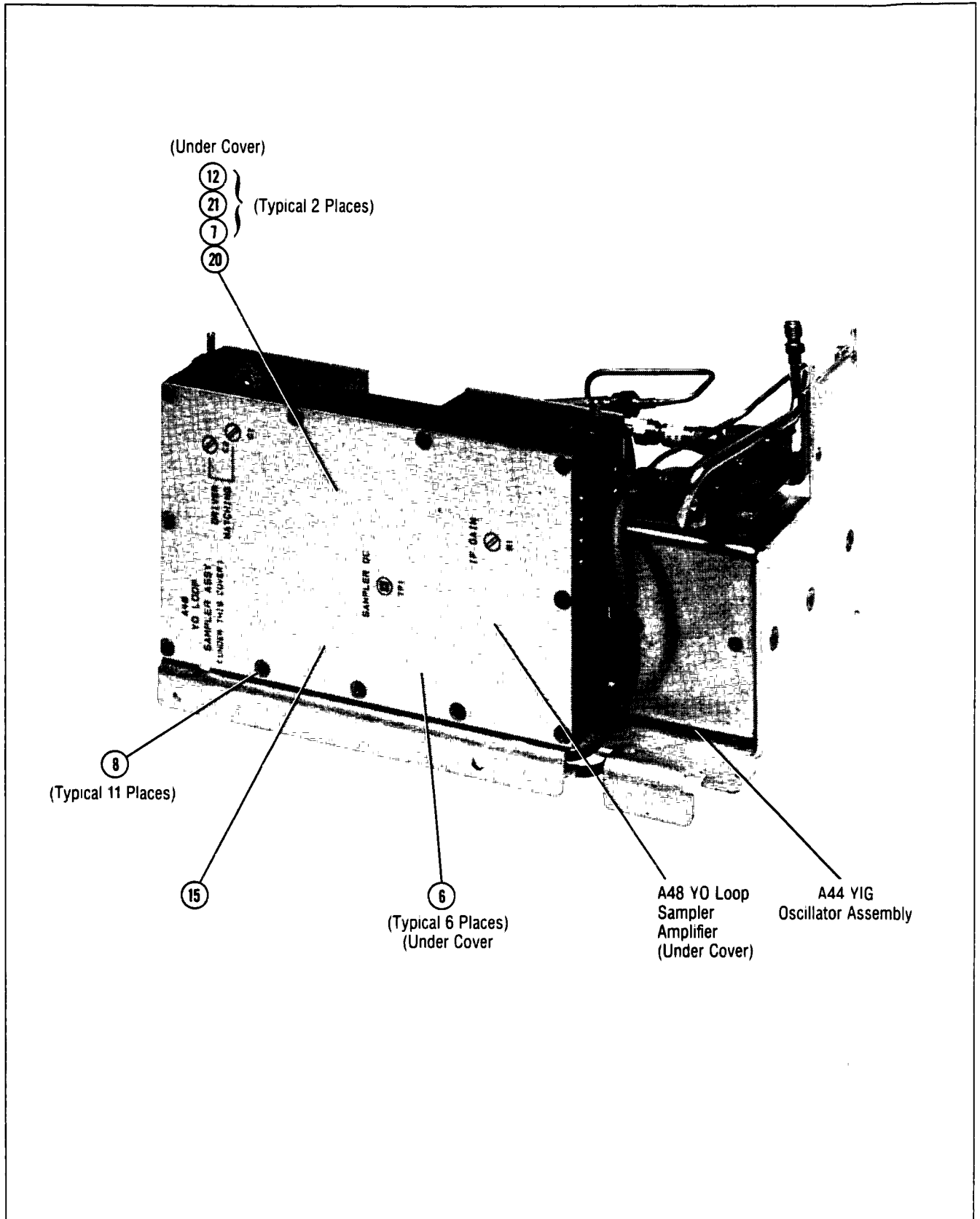

Figure A58-7. YO Loop Section Attaching Hardware (3 of 4)

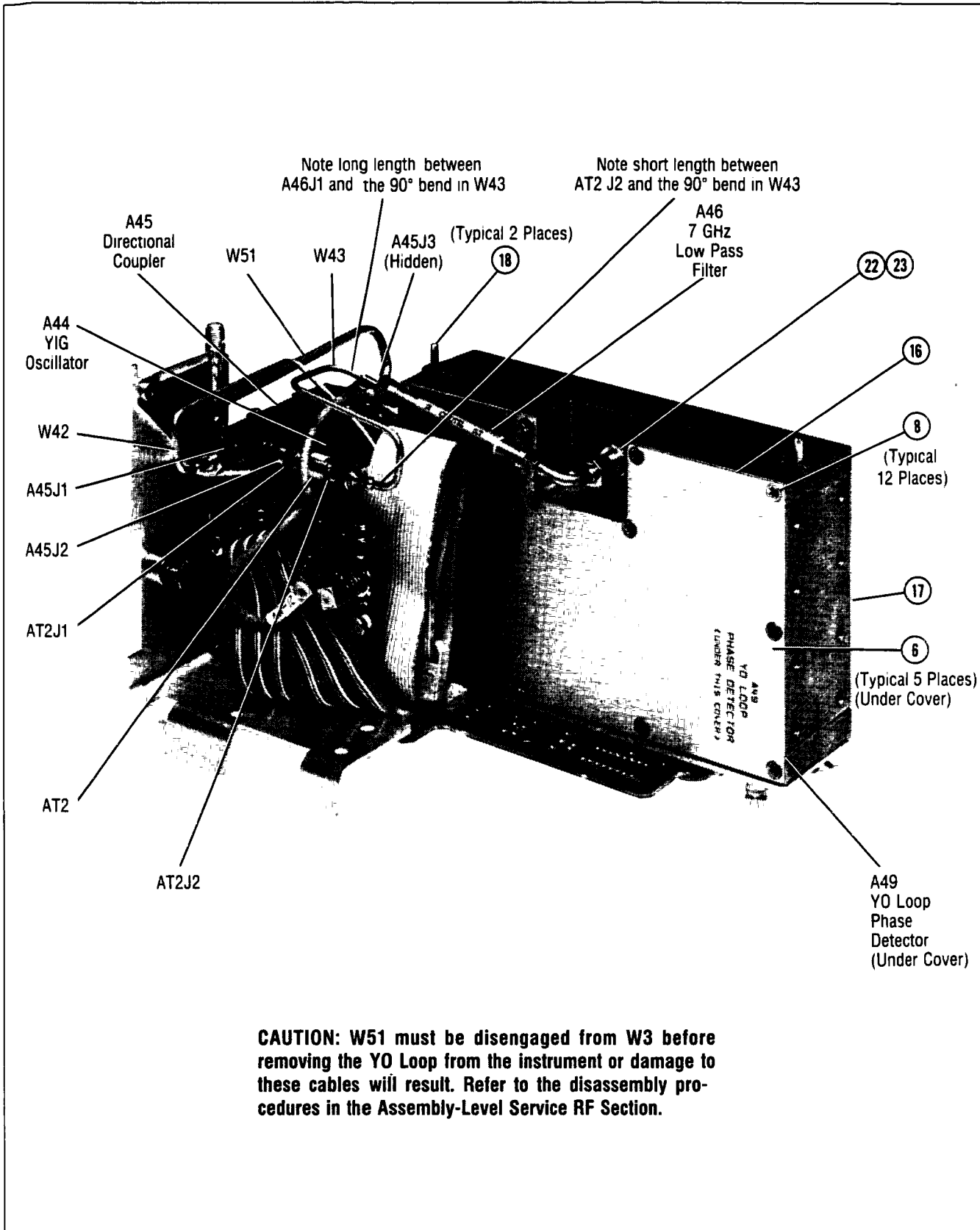

Figure A58-7. YO Loop Section Attaching Hardware (4 of 4)

A58 Sweep Generator Component-Level Troubleshooting

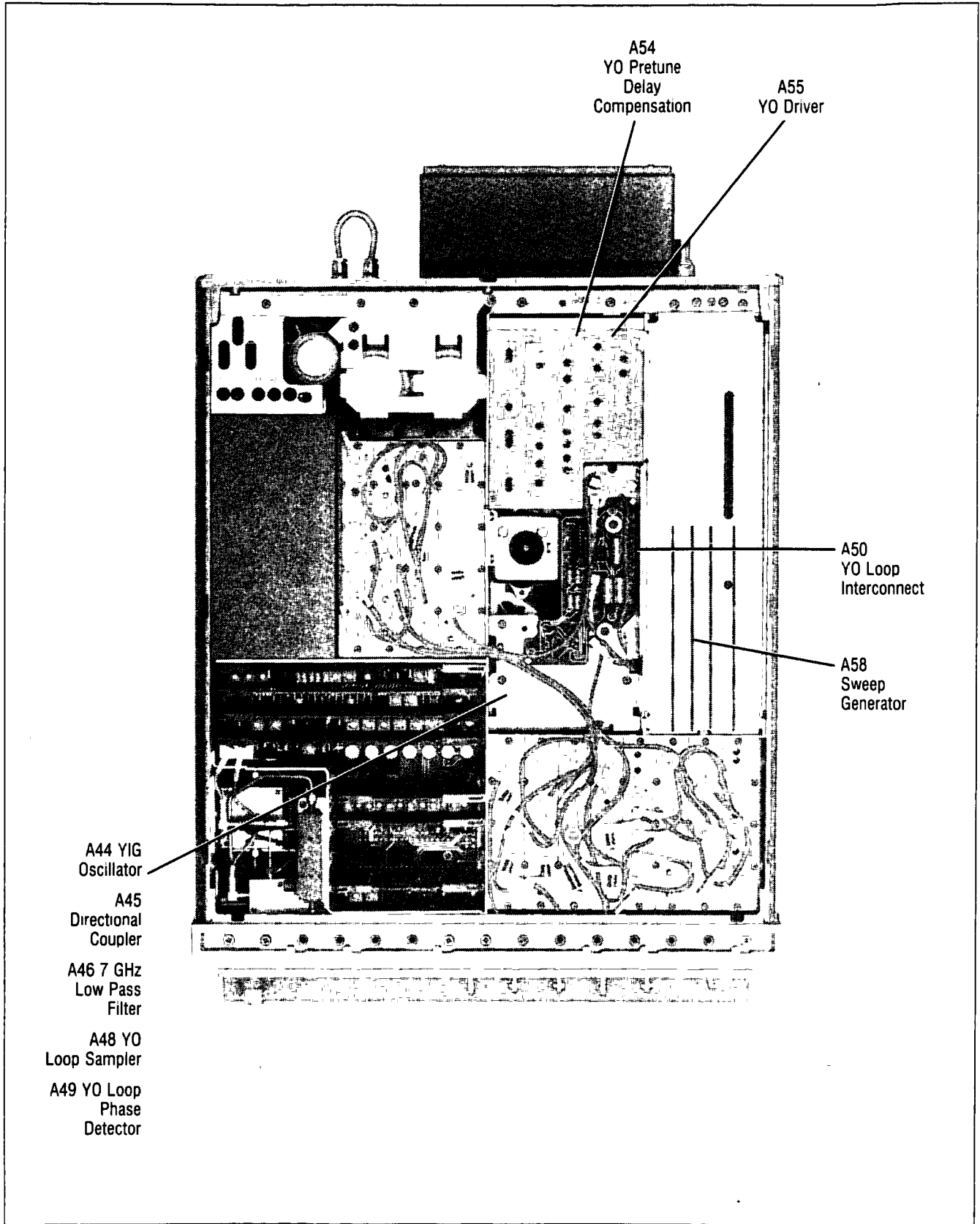

Figure A58-8. Sweep Generator and YO Loop Major Assemblies Location Diagram

A62 Motherboard Component-Level Service E

CONTENTS

A62 MOTHERBOARD

CIRCUIT DESCRIPTION	A62-1
Assembly Purpose	A62-1
Grounds	A62-1
TROUBLESHOOTING	A62-3
Component and Connector Replacement	A62-3
Motherboard Replacement	A62-4
MOTHERBOARD WIRING LIST	A62-8

A62 Motherboard Circuit Description

ASSEMBLY PURPOSE

The A62 motherboard is the common board to which many other assemblies are connected and serves to route signals between these assemblies. The A62 motherboard also routes signal to and from the front/rear panel connectors.

CAUTION

The A62 motherboard is large and complex; it contains six trace layers with several hundred separate signal paths. Read the entire motherboard section before troubleshooting, replacing any components, or making any repairs. It is recommended that the instrument be returned to Hewlett-Packard for repair of the motherboard. The A62 Motherboard is not field replaceable.

GROUNDS

The A62 motherboard has several different grounds:

- **STAR GND** — is the single ground reference point for analog circuitry in all major assemblies. Each assembly block is referenced to STAR GND via individual traces, minimizing ground noise crosstalk between major assemblies. STAR GND is a screw terminal located between the A62XA57 marker bandcross connector and A62J3 connector and is visible with the instrument top cover removed.
- **GND** — designates individual analog ground traces connecting major assembly blocks to STAR GND. Many of these traces are physically large and are used for high current power supply applications.
- **GND PLANE** — Refer to Figure A62-1.

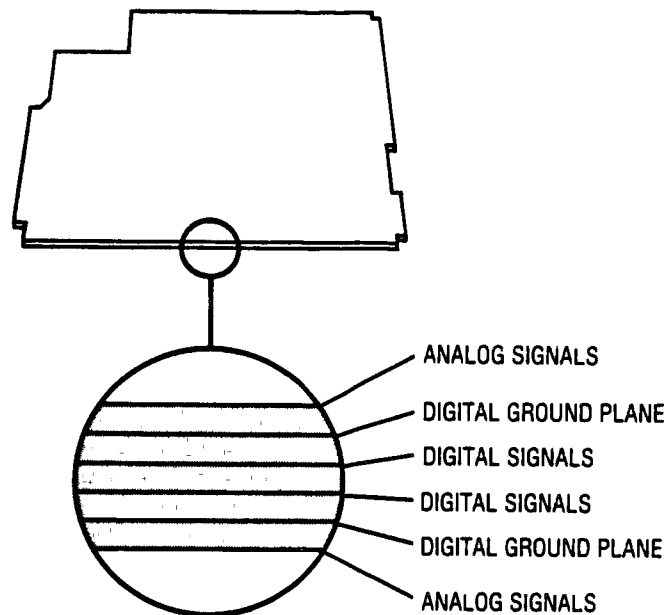

Figure A62-1. A62 Motherboard Cross Section

As shown in Figure E-1, analog and digital trace layers are separated by ground plane layers. These layers were designed to disperse any digital noise into the ground planes and act as an electrostatic shield between the digital and analog signal traces. The ground planes extend to each edge of the motherboard and are connected to STAR GND. This provides isolation between analog and digital grounds while reducing signal crosstalk.

- **REFERENCE GND** — is connected to STAR GND and is used as a very stable low current reference for integrated circuits and cable shields.
- **MISCELLANEOUS GROUND PLANES:**
 - A. The ground plane under the 20/30 Loops' aluminum casting completes a radio frequency interference (RFI) "box" comprised of the casting, assembly covers, and the 20/30 loops' ground plane. This ground plane is connected to STAR GND via a GND trace, and to chassis GND through the aluminum casting.
 - B. A ground plane under the M/N Loop's aluminum casting connects to STAR GND and is used as an RFI shield.
- **CHASSIS GND** — All grounds and ground planes are mechanically secured to the chassis (CHASSIS GND) around the instrument's perimeter and to various other parts of the A62 motherboard.

A62 Motherboard Component-Level Troubleshooting

The most common motherboard problems encountered are opens and shorts. If a signal is not present or is incorrect, refer to Table A62-1 and Figure A62-2 to determine the signal source and its location.

After ensuring that the signal source circuitry is functioning properly, isolate the source by removing destination assemblies where possible. In most cases, trouble occurs on other assemblies rather than on the motherboard itself.

Visually inspect the motherboard for possible loose hardware, stray component leads, solder splashes, and shorted or open traces. Be aware of feedthrough holes that may be making intermittent contact with inner layer motherboard traces.

CAUTION

Take extreme care when repairing either components or connectors on this assembly, or if repairing the motherboard itself. Because replacement of this assembly is very costly, Hewlett-Packard recommends that any motherboard or motherboard-component repair be done by an authorized Hewlett-Packard Service Center.

COMPONENT AND CONNECTOR REPLACEMENT

Repair and replacement of A62 Motherboard components and connectors is possible but successful only when the following guidelines are followed.

CAUTION

Unless otherwise mentioned, do not use a soldering iron with a tip temperature greater than 700° F, and leave the iron on the connection no longer than absolutely necessary. Take care not to damage wires, cables or other components located near the area being soldered.

Replacing Components

Where it is difficult to reach motherboard components with the soldering iron, you may have to remove individual assemblies. Refer to the replacement procedures of those assemblies for specific removal instructions.

Replacing Connectors

Connectors A62XA57-61 and A62J31 are male connectors whose pins can be individually replaced without replacing the entire connector.

NOTE: To get individual replacement pins which are not separately available; order an extra A62J31 connector and remove the individual pins from it.

All other motherboard connectors having the prefix XA must be completely replaced.



WARNING

Always wear safety glasses when soldering, desoldering, and breaking the plastic portion of connectors.

Single and dual in-line connectors having the prefix "J" (with the exception of J31) may be removed by heating each connector pin and removing the solder.



CAUTION

Do not use excessive heat.

To replace type SMC push-on coaxial connectors:

1. Heat the body from the component side of the board and remove it when the heat is sufficient. The center conductor will remain on the board.
2. Desolder the center conductor, then reheat each pad and remove the old solder.

MOTHERBOARD REPLACEMENT

The A62 motherboard is not customer/field replaceable. Direct any questions concerning Motherboard replacement to your nearest HP service center for more specific instructions. Refer to the HP service center listing at the end of this manual.

**A62 MOTHERBOARD
COMPONENT SIDE**

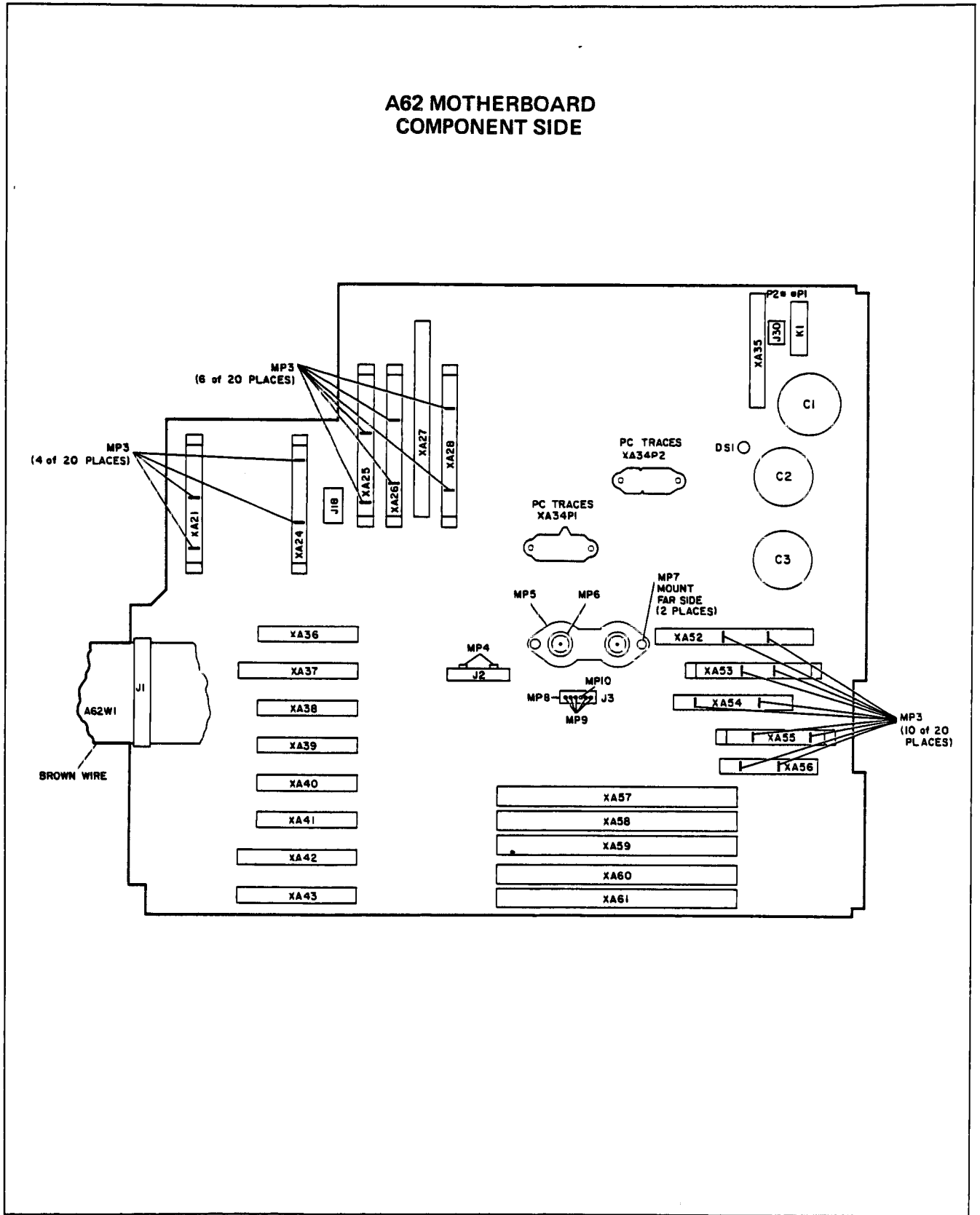

Figure A62-2. A62 Motherboard Component Location Diagram (1 of 2)

A62 MOTHERBOARD
SOLDER SIDE

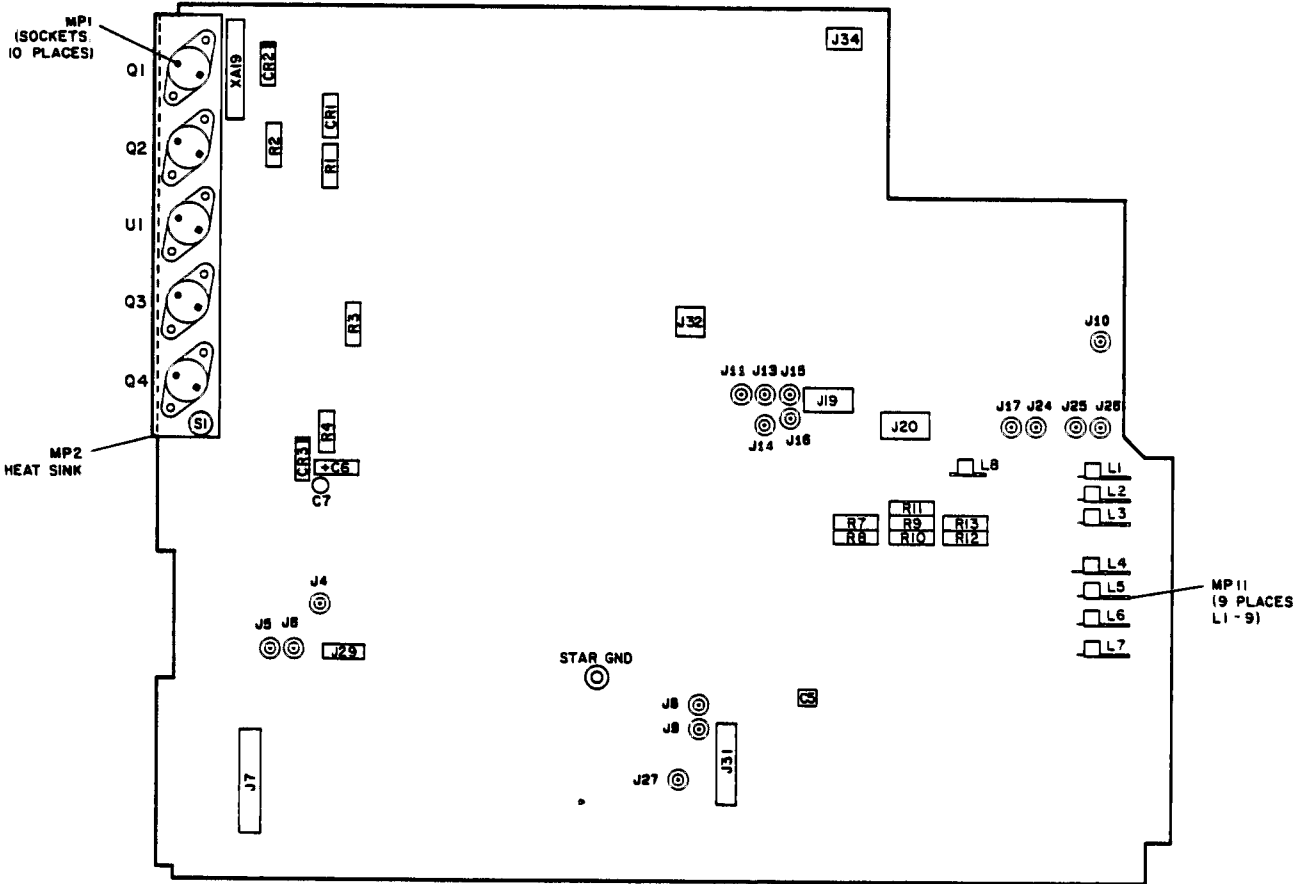

Figure A62-2. A62 Motherboard Component Location Diagram (2 of 2)

A62 Motherboard Component Level Troubleshooting

Table A62-1. Motherboard Wiring List

Mnemonic	Description	Type	Levels
ADRO ADR1 ADR2 ADR3 ADR4	INSTRUMENT I/O ADDRESS BUS BIT 0 INSTRUMENT I/O ADDRESS BUS BIT 1 INSTRUMENT I/O ADDRESS BUS BIT 2 INSTRUMENT I/O ADDRESS BUS BIT 3 INSTRUMENT I/O ADDRESS BUS BIT 4	DIGITAL DIGITAL DIGITAL DIGITAL DIGITAL	TTL TTL TTL TTL TTL
AM IN AM RTN	AMPLITUDE MODULATION INPUT AMPLITUDE MODULATION GROUND RETURN	ANALOG GROUND	±IV MAX. 0V
ATN ATNAT1 ATNAT2 ATNAT3 ATNAT4 ATN COIL + ATNTH1 ATNTH2 ATNTH3 ATNTH4	IEEE 488 ATTENTION (ATN) ATTENUATOR ATTENUATION CARD 1 ATTENUATOR ATTENUATION CARD 2 ATTENUATOR ATTENUATION CARD 3 ATTENUATOR ATTENUATION CARD 4 ATTENUATOR SOLENOID COILS SUPPLY ATTENUATOR THROUGH CARD 1 ATTENUATOR THROUGH CARD 2 ATTENUATOR THROUGH CARD 3 ATTENUATOR THROUGH CARD 4	DIGITAL DIGITAL DIGITAL DIGITAL DIGITAL POWER SUPPLY DIGITAL DIGITAL DIGITAL DIGITAL	TTL OPEN COLLECTOR OPEN COLLECTOR OPEN COLLECTOR OPEN COLLECTOR +5V OPEN COLLECTOR OPEN COLLECTOR OPEN COLLECTOR OPEN COLLECTOR
BVSWP	BUFFERED 0 TO 10V SWEEP RAMP	ANALOG	10V/SWEEP
DAV	IEEE 488 DATA VALID (DAV)	DIGITAL	TTL
DB0 DB1 DB2 DB3 DB4 DB5	INSTRUMENT I/O DATA BUS BIT 0 INSTRUMENT I/O DATA BUS BIT 1 INSTRUMENT I/O DATA BUS BIT 2 INSTRUMENT I/O DATA BUS BIT 3 INSTRUMENT I/O DATA BUS BIT 4 INSTRUMENT I/O DATA BUS BIT 5	DIGITAL DIGITAL DIGITAL DIGITAL DIGITAL DIGITAL	TTL TTL TTL TTL TTL TTL

A62 Motherboard Component Level Troubleshooting

Table A62-1. Motherboard Wiring List

Mnemonic	Source	Destination
ADR0 ADR1 ADR2 ADR3 ADR4	XA60-17 XA60-73 XA60-18 XA60-74 XA60-19	XA27-9, XA57-17, XA58-17, XA59-17, A62J1-23 XA27-40, XA57-73, XA58-73, XA59-73, A62J1-24 XA27-10, XA57-18, XA58-18, XA59-18, A62J1-25 XA27-41, XA57-74, XA58-74, XA59-74, A62J1-26 XA27-11, XA57-19, XA58-19, XA59-19, A62J1-27
AM IN AM RTN	A62J15 CENTER A62J15 SHIELD ^a	XA26-19 XA26-41, A62 SMC SHIELD AND GUARD TRACE AROUND AM IN
ATN ATNAT1 ATNAT2 ATNAT3 ATNAT4 ATN COIL + ATNTH1 ATNTH2 ATNTH3 ATNTH4	XA60-8 XA24-30 XA24-29 XA24-28 XA24-27 XA24-7 XA24-12 XA24-11 XA24-10 XA24-9	A62J7-21 A62J20-2 A62J20-9 A62J20-5 A62J20-10 A62J20-6 A62J20-13 A62J20-3 A62J20-11 A62J20-4
BVSWP	XA58-40	XA27-31
DAV	XA60-6	A62J7-11
DB0 DB1 DB2 DB3 DB4 DB5	XA60-20 ^b XA60-76 ^b XA60-21 ^b XA60-77 ^b XA60-22 ^b XA60-78 ^b	XA21-10, XA23-9, XA26-15, XA27-22, XA28-11, XA37-1, XA42-21, XA43-21, XA57-20, XA58-20, XA59-20, XA61-20 ⁱ , A62J1-3 XA21-11, XA23-27, XA26-37, XA27-53, XA28-34, XA37-19, XA42-3, XA43-3, XA54-10, XA57-76, XA58-76, XA59-76, A62J1-4 XA23-10, XA26-16, XA27-23, XA28-12, XA37-2, XA42-22, XA43-22, XA54-29, XA57-21, XA58-21, XA59-21, A62J1-5 XA23-28, XA26-38, XA27-54, XA28-35, XA37-20, XA42-4, XA43-4, XA54-11, XA57-77, XA58-77, XA59-77, A62J1-6 XA21-12, XA23-11, XA26-17, XA27-24, XA28-13, XA37-3, XA42-23, XA43-23, XA54-30, XA57-22, XA58-22, XA59-22, A62J1-7 XA21-13, XA23-29, XA27-55, XA28-36, XA37-21, XA42-5, XA43-5, XA54-12, XA57-78, XA58-78, XA59-78, A62J1-8

^a Multiple sources

^b Open collector bus — multiple sources.

ⁱ The A61 board assembly is not included with the HP 8340B. Traces connected to XA61 are included in this wiring list to keep signal destinations complete.

A62 Motherboard Component Level Troubleshooting

Table A62-1. Motherboard Wiring List

Mnemonic	Description	Type	Levels
DB6	INSTRUMENT I/O DATA BUS BIT 6	DIGITAL	TTL
DB7	INSTRUMENT I/O DATA BUS BIT 7	DIGITAL	TTL
DB8	INSTRUMENT I/O DATA BUS BIT 8	DIGITAL	TTL
DB9	INSTRUMENT I/O DATA BUS BIT 9	DIGITAL	TTL
DB10	INSTRUMENT I/O DATA BUS BIT 10	DIGITAL	TTL
DB11	INSTRUMENT I/O DATA BUS BIT 11	DIGITAL	TTL
DB12	INSTRUMENT I/O DATA BUS BIT 12	DIGITAL	TTL
DB13	INSTRUMENT I/O DATA BUS BIT 13	DIGITAL	TTL
DB14	INSTRUMENT I/O DATA BUS BIT 14	DIGITAL	TTL
DB15	INSTRUMENT I/O DATA BUS BIT 15	DIGITAL	TTL
DETLVL	DETECTED LEVEL INPUT TO A.D.C.	ANALOG	-0.2V/dB, 0V=0dB
DETOUT	DETECTED LEVEL INPUT TO LINEAR MOD BOARD	ANALOG	-0.3VdB, 0V=0dB
DET S/H+	DETECTOR SAMPLE/HOLD CONTROL	DIGITAL	+4.5V/+3.5V
DET S/H-	DETECTOR SAMPLE/HOLD CONTROL	DIGITAL	+3.5V/+4.5V
DIV N2	500 KHZ DIVIDED OUTPUT FROM PLL2 DIVIDER	DIGITAL	TTL (LOW TRUE)
DI01	IEEE 488 I/O DATA BUS BIT 1	DIGITAL	TTL
DI02	IEEE 488 I/O DATA BUS BIT 2	DIGITAL	TTL
DI03	IEEE 488 I/O DATA BUS BIT 3	DIGITAL	TTL
DI04	IEEE 488 I/O DATA BUS BIT 4	DIGITAL	TTL
DI05	IEEE 488 I/O DATA BUS BIT 5	DIGITAL	TTL
DI06	IEEE 488 I/O DATA BUS BIT 6	DIGITAL	TTL
DI07	IEEE 488 I/O DATA BUS BIT 7	DIGITAL	TTL
DI08	IEEE 488 I/O DATA BUS BIT 8	DIGITAL	TTL
EOI	IEEE 488 END OR IDENTIFY (EOI)	DIGITAL	TTL
EXDET	EXTERNAL DETECTOR INPUT	ANALOG	0.5mV TO 2V
EXDETR	EXTERNAL DETECTOR INPUT GROUND RETURN	GROUND	0V

A62 Motherboard Component Level Troubleshooting

Table A62-1. Motherboard Wiring List

Mnemonic	Source	Destination
DB6	XA60-23 ^b	XA21-14, XA23-12, XA26-39, XA27-25, XA28-14, XA37-4, XA42-24, XA43-24, XA54-31, XA57-23, XA58-23, XA59-23, A62J1-9
DB7	XA60-79 ^b	XA21-15, XA23-30, XA26-40, XA27-56, XA28-37, XA37-22, XA42-6, XA43-6, XA54-13, XA57-79, XA58-79, XA59-79, A62J1-10
DB8	XA60-24 ^b	XA21-31, XA23-13, XA27-26, XA28-15, THRU A62R7 TO XA36-2, XA37-5, XA42-25, XA43-25, XA54-32, XA57-24, XA58-24, XA59-24, A62J1-11
DB9	XA60-80 ^b	XA23-31, XA24-14, XA27-57, XA28-38, THRU A62R8 TO XA36-17, XA37-23, XA42-7, XA43-7, XA54-14, XA57-80, XA58-80, XA59-80, A62J1-12
DB10	XA60-25 ^b	XA23-14, XA24-15, XA27-27, XA28-16, THRU A62R9 TO XA36-3, XA37-7, XA42-26, XA43-26, XA54-33, XA57-25, XA58-25, XA59-25, A62J1-13
DB11	XA60-81 ^b	XA21-32, XA24-32, XA26-35, XA27-58, THRU A62R10 TO XA36-18, XA37-25, XA42-8, XA43-8, XA54-15, XA57-81, XA58-81, XA59-81, A62J1-14
DB12	XA60-26 ^b	XA24-16, XA54-34, XA57-26, XA58-26, XA59-26, A62J1-15
DB13	XA60-82 ^b	XA24-34, XA54-16, XA57-82, XA58-82, XA59-82, A62J1-16
DB14	XA60-27 ^b	XA54-35, XA57-27, XA58-27, XA59-27, A62J1-17
DB15	XA60-83 ^b	XA54-17, XA57-83, XA58-83, XA59-83, A62J1-18
DETLVL	XA25-33	XA27-29
DETOUT	XA25-32	XA26-10
DET S/H+	XA21-3	XA25-2
DET S/H-	XA21-21	XA25-24
DIV N2	XA42-27	XA41-19
DIO1	XA60-57	XA59-57, A62J7-1
DIO2	XA60-58	XA59-58, A62J7-3
DIO3	XA60-59	XA59-59, A62J7-5
DIO4	XA60-60	XA59-60, A62J7-7
DIO5	XA60-61	XA59-61, A62J7-2
DIO6	XA60-62	XA59-62, A62J7-4
DIO7	XA60-63	XA59-63, A62J7-6
DIO8	XA60-64	XA59-64, A62J7-8
EOI	XA60-7	XA59-7, A62J7-9
EXDET	A62J16 CENTER	XA25-44
EXDETR	A62J16 SHIELD ^a	XA25-43, GUARD TRACE AROUND EXDET

- ^a Multiple sources.
- ^b Open collector bus.

A62 Motherboard Component Level Troubleshooting

Table A62-1. Motherboard Wiring List

Mnemonic	Description	Type	Levels
EXT TRIG	EXTERNAL TRIGGER INPUT	TTL/ANALOG	EXT SOURCE LVL
FAN1 FAN2 FAN3 FAN4	SWITCHED FAN POWER SWITCHED FAN POWER PRIMARY FAN POWER PRIMARY FAN POWER	AC LINE AC LINE AC LINE AC LINE	110 VAC 110 VAC 110 VAC 110 VAC
FM OUT	FREQUENCY MODULATOR OUTPUT	ANALOG	
FM DRVR SHIELD	FREQUENCY MODULATOR OUTPUT SHIELD	GROUND	0V
FM INPUT	FREQUENCY MODULATOR INPUT	ANALOG	-8V TO +8V
FM SHIELD	FREQUENCY MODULATOR INPUT SHIELD	GROUND	0V
FPNLSWP FPNLSWP RTN	FRONT PANEL SWEEP RAMP FRONT PANEL SWEEP RAMP GROUND RETURN	ANALOG GROUND	10V/SWEEP 0V
GND	ANALOG GROUND	GROUND	0V
GND HPIB GND PLANE	IEEE 488 GROUND DIGITAL GROUND	GROUND GROUND	0V 0V

A62 Motherboard Component Level Troubleshooting

Table A62-1. Motherboard Wiring List

Mnemonic	Source	Destination
EXT TRIG	A62J31-4,22	XA57-106
FAN1 FAN2 FAN3 FAN4	A62K1-7 A62K1-10 A62P2 (SOLDER PAD) A62P1 (SOLDER PAD)	A62J30-3 A62J30-1 A62K1-5 A62K1-14, A62XA35
FM OUT	XA23-16	THRU A62J24 SMC CENTER TO A44J3
FM DRVR SHIELD	XA23-34	A62J24 SMC SHIELD
FM INPUT	XA23-18	A62J17 SMC CENTER
FM SHIELD	XA23-17	A62J17 SMC SHIELD
FPNLSWP FPNLSWP RTN	XA57-43 XA57-99	A62J9 SMC CENTER GUARD TRACE AROUND FPNLSWP, A62J9 SMC SHIELD
GND	NOTES ^{c,d,e,f}	XA19-10, 22, XA21-8, 26, XA22-5, 6, 23, 24 ^a , XA23-8, 26, XA24-8, XA25-9, 10, 31, XA26-6, 28, XA27-6, 37, XA28-6, 28, XA34P2-10, 11, XA35-4, 22, XA36-1, 5, 6, 7, 8, 10, 11, 14, 16, 19, 20, 21, 22, 26, 29, XA37-6, 9, 10, 13 THRU 17, 24, 27 THRU 35, XA38-1 THRU 11, 14 THRU 26, 29, 30, XA39-2 THRU 11, 13, 14, 17 THRU 26, 28, 29, XA40-2 THRU 6, 10, 14, 17, 21, 25, 29, XA41-1, 3, 6, 10, 11, 14, 16, 18, 21, 22, 25, 26, 29, XA42-10, 17, 20, 28, 35, XA43-11, 12, 13, 14, 17, 27, 29, 35, XA52-19, 43, XA53-14, 15, 16, 33, 34, 35, XA54-5, 23, XA55-5, 6, 20, 21, XA56-5, 20, A62J2-2, 19, A62J3-2, 4, A62J23 SHIELD, A62C2(-), A62C3(-), A62C5, A62C6(-), A62C7(-), A62R3, A62R14, CHASSIS, A62DS1 CATHODE M/N ASSY GND PLANE, T1 WHITE WIRE. ALL GROUNDS CONNECT TO THE 20/30 CASTING GND PLANE GROUNDED TO THE CHASSIS BY THE CASTING AND TO STAR GROUND
GND HPIB GND PLANE	CONNECTED TO REAR PANEL GND ^h	A62J7-12, 14, 16, 18, 20, 22, 23, 24 (NO CONNECTION — THESE ARE GROUNDED AT THE REAR PANEL) XA22-14, 32 ^a , XA23-6, 24, XA24-26, XA27-7, 19, 38, 50, XA57-1, 29, 30, 31, 34, 40, 55, 56, 70, 71, 72, 75, 84, 85, 86, 89, 110, XA58-1, 34, 44, 45, 46, 55, 56, 70, 71, 75, 89, 99, 101, 55, 110, XA59-1, 40 THRU 44, 55, 56, 75, 96, 97, 110, XA60-1, 40 THRU 44, 55, 56, 70, 71, 72, 75, 96 THRU 100, 110, XA61-1, 34, 40, 41, 42, 43, 44, 55, 56, 70, 71, 72, 75, 89, 96, 97, 98, 99, 100, 110 ⁱ , A62J1-1, 21, 29, 38, 39, 40, 41, 46, 48, 50, A62J20-1, A62J31-12, 35, A62J35-10, A62J19-1, 9, GND PLANE NEAR RF SECTION

- M/N assembly ground plane connected to Star Ground through W45.
- 20/30 loops casting
- Star Ground connected to A47W3, and also to the M/N assembly ground plane through W45.
- † Ground is connected to the chassis.
- Reserved for future expansion.
- Ground Plane is located near the RF Section.
- † The A61 board assembly is not included with the HP 8340B. Traces connected to XA61 are included in this wiring list to keep signal destinations complete.

Table A62-1. Motherboard Wiring List

Mnemonic	Description	Type	Levels
HADCEN HCEN HENDKICK HFILYO HINT HIPMOD DRV HLBW	A.D.C. CONVERT ENABLE YO DELAY COMPENSATION ENABLE YO AND YTM KICK PULSE COMPLETE FILTER YO ENABLE INTERNAL/EXTERNAL LEVELING CONTROL HIGH BAND PULSE MODULATOR DRIVE ALC LOOP BAND WIDTH CONTROL	DIGITAL DIGITAL DIGITAL DIGITAL DIGITAL ANALOG DIGITAL	TTL (HIGH TRUE) TTL (HIGH TRUE) TTL (HIGH TRUE) TTL (HIGH TRUE) TTL (HIGH TRUE) PIN DIODE CURRENT TTL (HIGH TRUE)
HLB0 HLB1 HLB2	ENCODED BAND INFO BIT 0 ENCODED BAND INFO BIT 1 ENCODED BAND INFO BIT 2	DIGITAL DIGITAL DIGITAL	TTL (HIGH TRUE) TTL (HIGH TRUE) TTL (HIGH TRUE)
HLEY HLE2	LOCK ENABLE FOR YO LOOP LOCK ENABLE TO PLL2	DIGITAL DIGITAL	TTL (HIGH TRUE) TTL (HIGH TRUE)
HMRKR HMTR HNUP HOVC HPLSEN	MARKER ASSERTED EXTERNAL METER LEVELING CONTROL NEGATIVE POWER SUPPLIED UP SIGNAL INTERNAL 10 MHZ STANDARD TEMP ERROR PULSE MODULATION ENABLED	DIGITAL DIGITAL DIGITAL ANALOG DIGITAL	TTL (HIGH TRUE) TTL (HIGH TRUE) TTL (HIGH TRUE) +3V - OVEN WARM TTL L(HIGH TRUE)
HPUP HRFON HSP HSTD	POSITIVE POWER SUPPLIES UP SIGNAL RF OUTPUT POWER ON SWEEP IN PROGRESS INTERNAL 10 MHZ STANDARD ENABLE	DIGITAL DIGITAL DIGITAL DIGITAL	TTL (HIGH TRUE) TTL (HIGH TRUE) TTL (HIGH TRUE) TTL (HIGH TRUE)
HULH HULM HULR HULY HUL1 HUL2	3.7 GHZ OSCILLATOR UNLOCKED M/N OSCILLATOR UNLOCKED REFERENCE OSCILLATOR UNLOCKED YO 2-7 GHZ OSCILLATOR UNLOCKED PLL1 OSCILLATOR UNLOCKED PLL2 OSCILLATOR UNLOCKED	DIGITAL DIGITAL DIGITAL DIGITAL DIGITAL DIGITAL	TTL (HIGH TRUE) TTL (HIGH TRUE) TTL (HIGH TRUE) TTL (HIGH TRUE) TTL (HIGH TRUE) TTL (HIGH TRUE)

A62 Motherboard Component Level Troubleshooting

Table A62-1. Motherboard Wiring List

Mnemonic	Source	Destination
HADCEN HCEN HENDKICK HFILYO HINT HIPMOD DRV HLBW	XA21-1 XA59-67 XA28-18 XA59-47,72 XA26-42 XA21-36 XA26-33	XA27-8 XA55-14 XA24-31 XA58-72, A62J2-5 XA21-28, XA25-42 A62J25 SMC CENTER XA21-6, XA25-11
HLB0 HLB1 HLB2	XA27-46 XA27-16 XA27-47	XA24-20, XA26-29, XA28-31 XA24-21, XA26-30, XA28-32 XA24-22, XA26-31, XA28-33
HLEY HLE2	XA59-51 XA59-53	A62J2-3 XA41-2, XA42-2, XA43-2
HMRKR HMTR HNUP HOVC HPLSEN	XA57-2,12 XA26-13 XA53-17, XA56-1,16 A62J3-3 XA26-2	XA26-43 XA21-20, XA25-36 XA52-44 XA59-10, XA61-85 [†] XA21-9, XA25-3
HPUP HRFON HSP HSTD	XA52-46 XA57-105 XA57-13 XA59-66	XA59-95, XA60-95, XA61-95 [†] , A62J1-22 XA21-27, XA26-24 XA26-7, XA28-26, XA55-22, XA58-13, XA59-13, A62J2-14 XA52-21
HULH HULM HULR HULY HUL1 HUL2	A62J19-16 XA34P1-8 XA34P2-14 A62J2-16 XA37-26, XA39-1,16 XA41-4	XA57-49,104, XA59-105 XA59-104 XA59-49 XA59-50 XA59-106 XA59-107

[†] The A61 board assembly is not included with the HP 8340B. Traces connected to XA61 are included in this wiring list to keep signal destinations complete.

A62 Motherboard Component Level Troubleshooting

Table A62-1. Motherboard Wiring List

Mnemonic	Description	Type	Levels
HXREF IFC	EXTERNAL REFERENCE ENABLE IEEE 488 INTERFACE CLEAR (IFC)	DIGITAL DIGITAL	TTL (HIGH TRUE) TTL (LOW TRUE)
L ADR HOLD LALTEN LALTSSEL LATTN LBX LCHNG	(USED FOR FACTORY PROGRAMMING ONLY) ALTERNATE MODE ENABLED CURRENT INST. STATE (FORE/BACK GROUND) ATTENUATOR INSTALLED SENSING BAND CROSS INSTRUMENT STATE CHANGED	DIGITAL DIGITAL DIGITAL DIGITAL DIGITAL DIG. OPEN COLL.	TTL (LOW TRUE) TTL (LOW TRUE) TTL (LOW TRUE) TTL (LOW TRUE) TTL (LOW TRUE) TTL (LOW TRUE)
LCK1 LCK2 LCK3 LCK4	DATA STROBE TO PLL2 COUNTERS (0, R2:) DATA STROBE TO PLL2 DIR. DIVIDER (0, R0:) DATA STROBE TO PLL2 PRETUNE DAC (0, R1:) DATA STROBE TO PLL1 VCO GAIN SWITCH (0, R3:)	DIGITAL DIGITAL DIGITAL DIGITAL	TTL (LOW TRUE) TTL (LOW TRUE) TTL (LOW TRUE) TTL (LOW TRUE)
LDETBW LHET LHIBND LHSOT LHSOT RTN	DETECTOR LOW BAND WIDTH CONTROL HETRODYNE BAND ENABLED FUNDAMENTAL OR MULTIPLIED BAND ENABLED HEAT SINK OVER TEMPERATURE SENSOR HEAT SINK OVER-TEMP SENSOR BND RETURN	DIGITAL DIGITAL DIGITAL DIGITAL GROUND	TTL (LOW TRUE) TTL (LOW TRUE) TTL (LOW TRUE) TTL (LOW TRUE) 0V
LINE TRIG	LINE TRIGGER SENSING 5V SECONDARY	RECTIFIED AC	LINE FREQ 7V TO -10V
LIPS LKICKYO LMNE LMODHLD LOMD LOPMOD DRV	INSTRUMENT - PRESET LOW KICK PULSE M/N OSCILLATOR LOCK ENABLED LINEAR MODULATOR SAMPLE/HOLD OVER-MODULATION DETECTED LOW BAND PULSE MODULATOR DRIVE	DIG. OPEN COLL. ANALOG DIGITAL DIGITAL DIG. OPEN COLL. ANALOG	TTL (LOW TRUE) 0 TO +5V TTL (LOW TRUE) TTL TTL (LOW TRUE) CURRENT SOURCE
LPROG	(USED FOR FACTORY PROGRAMMING ONLY)	DIGITAL	TTL (LOW TRUE)

A62 Motherboard Component Level Troubleshooting

Table A62-1. Motherboard Wiring List

Mnemonic	Source	Destination
HXREF IFC	A62J31-21 A62J7-17	XA58-108, XA59-98 XA60-3
L ADR HOLD LALTEN LALTSEL LATTN LBX LCHNG	XA60-45 XA57-60 XA57-59 A62J20-14 XA57-69, XA58-69, XA59-69 NOTE ^b	XA61-45 ⁱ A62J31-9,27 A62J31-10,28 XA27-39 XA27-21, XA58-100, XA59-45
LCK1 LCK2 LCK3 LCK4	XA59-54 XA59-109 XA59-108 XA59-52	XA42-19 XA42-1 XA43-19 THRU A62R11 TO XA36-4, XA37-8
LDETBW LHET LHIBND LHSOT LHSOT RTN	XA26-9 XA27-20 XA26-23 A62J31-30 A62J31-12	XA25-39, A62J34-2 XA21-29, XA25-37, A62J19-7,8 A62J19-15 XA52-12 GND PLANE
LINE TRIG	A62CR1 CATHODE	XA57-57,68, THRU A62R1 TO PWR ON LED
LIPS LKICKYO LMNE LMODHLD LOMD LOPMOD DRV	XA52-36, A62J1-19 XA54-19 XA59-86 XA21-2 XA26-8, A62J2-7 XA21-16	XA57-14, XA58-14, XA59-14, XA60-14, XA61-14 ⁱ XA55-1 XA34P1-2 XA26-1 XA27-48 A62J10 SMC CENTER
LPROG	XA60-101	XA61-101 ⁱ

^b Open collector bus - multiple sources.

ⁱ The A61 board assembly is not included with the HP 8340B. Traces connected to XA61 are included in this wiring list to keep signal destinations complete.

A62 Motherboard Component Level Troubleshooting

Table A62-1. Motherboard Wiring List

Mnemonic	Description	Type	Levels
LRETRACE LRSP LSBY LSPLD	RETRACE RESET SWEEP CONTROL STANDBY CONTROL SWEEP L.E.D. CONTROL OFF/ON	DIGITAL DIGITAL DIGITAL DIGITAL	TTL (LOW TRUE) TTL (LOW TRUE) 0V TO +22V TTL
LSSP LSRQ LSTEPUP LSTP LUNLVL	STEP SWEEP SERVICE REQUEST STEP UP FOR EXTERNAL FOOT SWITCH PROCESSOR STOPPED INSTRUMENT UNLEVELED	DIG. OPEN COLL DIG. OPEN COLL. DIGITAL DIGITAL DIG. OPEN COLL	TTL (LOW TRUE) TTL (LOW TRUE) TTL (LOW TRUE) TTL (LOW TRUE) TTL (LOW TRUE)
LVLCOR LVLREF LVSX LYOKICK LYSP	LEVELING CORRECTION A L.C. LEVEL REFERENCE DISABLE YO SWEEPS YO SWEEP	ANALOG ANALOG DIGITAL DIGITAL	1.25 dB/V 0V=0dB .2V/dB 0V=0dBm TTL (LOW TRUE) TTL (LOW TRUE)
MKR RMP	SWEEP RAMP TO MARKER BANDCROSS BOARD	ANALOG	0 TO 10V/SWEEP
MOD RTN	ALC MODULATORS GROUND RETURN	GROUND	0V
MODHI MODLO MODLVL	HIGH BAND MODULATOR DRIVE LOW BAND MODULATOR DRIVE MODULATOR LEVEL	ANALOG ANALOG ANALOG	CURRENT SOURCE CURRENT SOURCE 0 TO -3 LEVELED
MUTE	PLOTTER MUTE CONTROL	DIGITAL	TTL (HIGH TRUE)
M1 M2 M3 M4 M5	M NUMBER TO M/N OSCILLATOR BIT 1 M NUMBER TO M/N OSCILLATOR BIT 2 M NUMBER TO M/N OSCILLATOR BIT 3 M NUMBER TO M/N OSCILLATOR BIT 4 M NUMBER TO M/N OSCILLATOR BIT 5	DIGITAL DIGITAL DIGITAL DIGITAL DIGITAL	TTL (HIGH TRUE) TTL (HIGH TRUE) TTL (HIGH TRUE) TTL (HIGH TRUE) TTL (HIGH TRUE)

A62 Motherboard Component Level Troubleshooting

Table A62-1. Motherboard Wiring List

Mnemonic	Source	Destination
LRETRACE LRSP LSBY LSPLD	XA57-58 XA59-85 A62J1-20 XA58-67	A62J31-11,29 XA58-85 XA52-45, A62CR2 ANODE A62J1-44
LSSP LSRQ LSTEPUP LSTP LUNLVL	XA57-107 NOTE ^b A62J31-14 XA59-65 XA26-36	A62J31-5,23 XA57-54, XA58-54, XA59-89, XA60-89, A62J1-45 A62J1-28 XA60-65, A62J1-43 XA27-52
LVLCOR LVLREF LVSX LYOKICK LYSP	XA25-14 XA27-30 XA58-68 XA54-21 XA59-11	XA27-62 XA25-13 XA54-9 XA28-41 XA55-7
MKR RMP	XA58-96	XA57-96
MOD RTN	XA26-21	A62J13 SMC SHIELD, A62J14 SMC SHIELD, GUARD TRACE AROUND MODHI AND MODLO
MODHI MODLO MODLVL	XA26-20 XA26-22 XA26-32	A62J13 SMC CENTER A62J14 SMC CENTER XA27-61
MUTE	XA57-61	A62J31-8.26
M1 M2 M3 M4 M5	XA59-33 XA59-88 XA59-32 XA59-87 XA59-31	XA34P1-5 XA34P1-6 XA34P1-3 XA34P1-4 XA34P1-1

^b Open collector bus - multiple sources.

Table A62-1. Motherboard Wiring List

Mnemonic	Description	Type	Levels
NDAC NEG BLANK NRFD	IEEE 488 NOT DATA ACCEPTED (NDAC) NEGATIVE BLANKING SIGNAL IEEE 488 NOT READY FOR DATA (NRFD)	DIGITAL DIGITAL DIGITAL	TTL 0, -5V TTL
N1 N2	N NUMBER TO M/N OSCILLATOR BIT 1 N NUMBER TO M/N OSCILLATOR BIT 2	DIGITAL DIGITAL	TTL TTL
N2 TUNE N2 TUNE RTN	TUNING SIGNAL TO PLL2 VCO GROUND RETURN	ANALOG GROUND	0V TO +7V 0V
N3 N4 N5 N6	N NUMBER TO M/N OSCILLATOR BIT 3 N NUMBER TO M/N OSCILLATOR BIT 4 N NUMBER TO M/N OSCILLATOR BIT 5 N NUMBER TO M/N OSCILLATOR BIT 6	DIGITAL DIGITAL DIGITAL DIGITAL	TTL TTL TTL TTL
PEN LIFT PEN LIFT RTN	PLOTTER PEN LIFT PLOTTER PEN LIFT GROUND RETURN	OPEN COLLECTOR GROUND	CLAMP AT 56 V 0V
PH1	PLL1 PHASE DETECTOR OUTPUT	ANALOG	0V TO +5V
PH2	PLL1 PHASE DETECTOR OUTPUT	ANALOG	0V TO +5V
PINBIAS PLS IN PLS IN RTN	SYTM P.I.N. DIODE BIAS EXTERNAL PULSE INPUT EXTERNAL PULSE GROUND RETURN	DIGITAL DIGITAL GROUND	-4V TO +12V TTL 0V
PMOD RTN	PULSE MODULATOR DRIVE GROUND RETURN	GROUND	0V
PRETUNE	YO PRETUNE	ANALOG	-2.5V/GHz 0 \cong 2GHz
PWR ON LED	+5 Vac THROUGH CR1 AND R1 TO DSI	POWER SUPPLY	+ .78V ANODE - ON
Q1B Q1E	TRANSISTOR Q1 BASE TRANSISTOR Q1 EMITTER	ANALOG ANALOG	

A62 Motherboard Component Level Troubleshooting

Table A62-1. Motherboard Wiring List

Mnemonic	Source	Destination
NDAC NEG BLANK NRFD	XA60-4 XA57-41 XA60-5	A62J7-15 A62J31-1,19 A62J7-13
N1 N2	XA59-48 XA59-103	XA34P1-15 XA34P1-14
N2 TUNE N2 TUNE RTN	XA41-23 XA41-8	XA43-28 XA43-10
N3 N4 N5 N6	XA59-47 XA59-102 XA59-46 XA59-101	XA34P1-13 XA34P1-12 XA34P1-11 XA34P1-10
PEN LIFT PEN LIFT RTN	XA57-108 XA57-109	A62J31-6,24 A62J31-25
PH1	A62R12	XA36-24, THRU A62R12 TO XA37-11
PH2	A62R13	XA36-25, THRU A62R13 TO XA37-12
PINBIAS PLS IN PLS IN RTN	XA24-24 A62J26 CENTER NOTE *	A62J18-10 XA21-18 XA21-17, GUARD TRACE AROUND PLS IN, A62J26 SMC SHIELD
PMOD RTN	XA21-35	GUARD TRACE AROUND HIPMOD AND LOPMOD DRV, A62J25 SMC SHIELD, A62J10 SMC SHIELD
PRETUNE	XA54-24	XA55-8,23, A62J5 SMC CENTER THRU COAX TO A62J11 SMC CENTER, XA28-22
PWR ON LED	A62R1	A62DS1 ANODE, THRU A62R1 TO LINE TRIG
Q1B Q1E	XA53-4 XA53-7,8,25,26	Q1 BASE Q1 EMITTER

* Multiple sources.

A62 Motherboard Component Level Troubleshooting

Table A62-1. Motherboard Wiring List

Mnemonic	Description	Type	Levels
Q2B Q2E Q3B Q3C Q3E Q4B	TRANSISTOR Q2 BASE TRANSISTOR Q2 EMITTER TRANSISTOR Q3 BASE TRANSISTOR Q3 COLLECTOR TRANSISTOR Q3 EMMITER TRANSISTOR Q4 BASE	ANALOG ANALOG ANALOG ANALOG ANALOG ANALOG	
Q4C	TRANSISTOR Q4 COLLECTOR	ANALOG	
Q4E	TRANSISTOR Q4 EMITTER	ANALOG	
REN RFSWP	IEEE 488 REMOTE ENABLE (REN) SWEEP RAMP TO RF OUTPUT SECTION	DIGITAL ANALOG	TTL (LOW TRUE) 10V/SWEEP
RGND	REFERENCE GROUND	GROUND	0V
RPNSWP RPNSWP RTN	REAR PANEL SWEEP OUTPUT REAR PANEL SWEEP GROUND RETURN	ANALOG GROUND	10V/SWEEP 0V
RSTAT	READ STATUS I/D STROBE (15, R3)	DIGITAL	TTL (LOW TRUE)
SIOA SIOB SPARE 1 SPARE 2 SR FBK SR PWR	I/O STROBE (FIRST HALF ADDRESSES) I/O STROBE (SECOND HALF ADDRESSES) DB0 OUTPUT MISCELLANEOUS CONTROL DB1 OUTPUT MISCELLANEOUS CONTROL Y0 SENSE RESISTOR FEEDBACK Y0 SENSE RESISTOR POWER	DIGITAL DIGITAL DIGITAL DIGITAL ANALOG ANALOG	TTL (LOW TRUE) TTL (LOW TRUE) TTL TTL -5 TO -17V -5V TO -17V

A62 Motherboard Component Level Troubleshooting

Table A62-1. Motherboard Wiring List

Mnemonic	Source	Destination
Q2B Q2E Q3B Q3C Q3E Q4B	XA53-21 XA53-1,19 XA52-7 XA52-6,30 XA52-8,32 XA52-3,27	Q2 BASE Q2 EMITTER Q3 BASE Q3 COLLECTOR Q3 EMITTER Q4 BASE
Q4C	XA52-1,2,25,26	Q4 COLLECTOR
Q4E	XA52-4,5,28,29	Q4 EMITTER
REN RFSWP	A62J7-10 XA57-42	XA60-2 XA27-17
RGND	A62 STAR GROUND POINT	XA23P1-6, 24, XA24-36, XA25-12, 34, XA26-11, 34, XA27-18, 28, 49, 60, XA28-21, 43, XA43-20, XA54-7, 25, XA55-10, 11, 25, 26, XA57-45, 46, 101 XA58-42, 43, 98, A62J4 SMC SHIELD, A62J5 SMC SHIELD, A62J6 SMC SHIELD, A62J11 SMC SHIELD A62J18 SMC SHIELD, A62J27 SMC SHIELD, A62J29-1 AND LUG NEXT TO A62J29, A62J32-1, GROUND TRACE NEXT TO 20/30 SWP, GROUND TRACE NEAR VSWP, GUARD TRACE AROUND PRETUNE, GUARD TRACE NEAR YO TUNE. GUARD TRACE AROUND PRETUNE, GUARD TRACE AROUND SYTMRES
RPNLSWP RPNLSWP RTN	XA57-44 XA57-100	A62J8 CENTER GUARD TRACE AROUND RPNL SWP. A62J8 SMC SHIELD
RSTAT	XA27-45	XA23-32, XA24-23, XA28-10
SIOA SIOB SPARE 1 SPARE 2 SR FBK SR PWR	XA60-15 XA60-16 A62J35-8 A62J35-6 XA55-12,27 XA55-13,28	XA27-42, XA57-15, XA58-15, XA59-15, A62J1-49 XA57-16. XA58-16, XA59-16, A62J1-47 XA59-71 XA59-70 A62J29-2 A62J29-3

A62 Motherboard Component Level Troubleshooting

Table A62-1. Motherboard Wiring List

Mnemonic	Description	Type	Levels
SRD BIAS SRD BIAS CONT SRQ STAT10	STEP RECOVERY DIODE BIAS STEP RECOVERY DIODE BIAS CONTROL IEEE 488 SERVICE REQUEST (SRQ) STATUS WORD INPUT BIT 10	ANALOG DIGITAL DIGITAL DIGITAL	-10V/2K TO +5V 0 TO -5 LEVELED TTL TTL (LOW TRUE)
SW1 SW2	PLL1 15-30 MHZ ON/OFF CONTROL PLL1 .15 TO .3 MHZ/3-6 MHZ CONTROL	DIGITAL DIGITAL	TTL TTL
SYTM COIL + SYTM COIL - SYTM GND SYTMDB SYTMDC SYTMHTR SYTMRES SYTM TEMP SYTMTHRM	POSITIVE INPUT TO SYTM COIL NEGATIVE INPUT TO SYTEM COIL SYTM GROUND SYTM DRIVE TRANSISTSOR BASE SYTM DRIVE TRANSISTOR COLLECTOR REGULATOR HEATER DRIVE TO SYTM SYTM CURRENT SENSE FEED BACK SYTM TEMPERATURE COIL TEMP FEED BACK THERMISTOR IN SYTM	ANALOG ANALOG GROUND ANALOG ANALOG ANALOG ANALOG ANALOG ANALOG	-40V TO -25V -40V 0V -22 TO -39 -.6 TO -6V 0 TO +20V -.9V LOW BND CW 100 mv/c° APPROX -5V
TCREF THERM1 THERM2 TYOKP	ALC TEMP COMPENSATED REFERENCE LOW BAND DETECTOR THERMISTOR LOW BAND DETECTOR THERMISTOR TRIGGER YO KICK PULSE	ANALOG ANALOG ANALOG DIGITAL	-.2V/dB 0V=0dBm -1V TO -8V -10V TTL (LOW TRUE)
VCOMP VSWP	YO DELAY COMPENSATION VOLTAGE YO SWEEP RAMP	ANALOG ANALOG	-26 MHZ/VOLT 0V TO 10V/SWEEP
WBAND WCDAC WLEVEL WMOD WPDAC WRDAC	BAND INFO I/O STROBE (10, R2:) DELAY COMPENSATION DAC DATA STROBE (5, R3:) ALC REFERENCE DAC DATA STROBE (10, R1:) MODULATION DATA STROBE (10, R0:) PRE-TUNE DAC DATA STROBE (3, R2:) RESET DAC DATA STROBE (1, R2:)	DIGITAL DIGITAL DIGITAL DIGITAL DIGITAL DIGITAL	TTL (LOW TRUE) TTL (LOW TRUE) TTL (LOW TRUE) TTL (LOW TRUE) TTL (LOW TRUE) TTL (LOW TRUE)

A62 Motherboard Component Level Troubleshooting

Table A62-1. Motherboard Wiring List

Mnemonic	Source	Destination
SRD BIAS SRD BIAS CONT SRQ STAT10	XA24-25 XA26-18 A62J7-19 XA23-22	A62J18-2 XA24-13 XA60-9 XA24-4
SW1 SW2	XA42-32 XA42-14	XA36-23, XA40-24 XA40-22
SYTM COIL + SYTM COIL - SYTM GND SYTMDB SYTMDC SYTMHTR SYTMRES SYTM TEMP SYTMTHRM	XA28-42 A62J18-12 A62J18-13,14,15 XA28-19 XA28-20 XA24-19 XA28-44 A62J18-5 A62J18-9	A62J18-4, A62J32-3 XA28-5,27 XA24-35 A62J32-2 A62J32-4 A62J18-8 A62J32-5 XA27-13 XA24-2
TCREF THERM1 THERM2 TYOKP	XA25-35 A62J34-3 A62J34-1 XA59-100	XA26-12 XA25-4 XA25-26 XA54-18, XA58-30
VCOMP VSWP	XA54-27 XA58-97	XA55-9 A62J27 SMC CENTER THRU COAX TO A62J4 SMC CENTER. XA54-26
WBAND WCDAC WLEVEL WMOD WPDAC WRDAC	XA27-43 XA59-30 XA27-12 XA27-59 XA59-68 XA59-29	XA28-29 XA54-28 XA24-33 XA21-33, XA23-33, XA26-44 XA54-36 XA58-29

A62 Motherboard Component Level Troubleshooting

Table A62-1. Motherboard Wiring List

Mnemonic	Description	Type	Levels
WSPAT WSPTM WYOKW WYTMCTL WYTMSLP W11R2	SWEEP ATTENUATOR DATA STROBE (1, R0:) SWEEP TIME DAC DATA STROBE (1, R1:) YO KICK PULSE WIDTH DATA STROBE (5, R1:) YTM CONTROL SIGNALS STROBE (11, R1:) YTM DRIVE SLOPE DAC DATA STROBE (11, R1:) EXTRA I/O STROBE (11, R2:)	DIGITAL DIGITAL DIGITAL DIGITAL DIGITAL DIGITAL	TTL (LOW TRUE) TTL (LOW TRUE) TTL (LOW TRUE) TTL (LOW TRUE) TTL (LOW TRUE) TTL (LOW TRUE)
YO COIL + YO COIL - YO TUNE YOXISTB	POSITIVE INPUT TO YO COIL NEGATIVE INPUT TO YO COIL LOW FREQ PHASE LOCK TO YO DRIVER YO DRIVE TRANSISTOR BASE	ANALOG POWER SUPPLY ANALOG ANALOG	-40V TO -20V -40V 0V TO ±6V -30V TO -39V
Z-AXIS BLANK	2-AXIS BLANKING/MARKER	DIGITAL	+5V/-5V
1.4V/GHZ 20/30 SWP 500 KHZ REF 8410 TRIG	1.4V PER GHZ REFERENCE 20/30 MHZ REFERENCE OSCILLATOR SWEEP PLL2 500 KHZ REFERENCE SYNCHRONIZING TRIGGER TO 8410B INTERFACE	ANALOG ANALOG DIGITAL DIGITAL	+1.4V/GHZ 0V TO +10V TTL TTL
+1.0 V/GHZ +1.0 V/GHZ RTN +5V AC1	+1.0V/GHZ FREQUENCY REFERENCE +1 0V/GHZ FREQUENCY REFERENCE GROUND RETURN +5V TRANSFORMER SECONDARY	ANALOG GROUND TI SEC.	1 0V/GHZ 0V 7 VAC
+5V AC2	+5V TRANSFORMER SECONDARY (GREEN)	TI SEC.	7 VAC
+5V SENSE (+) +5V SENSE (-) +5V UNREG	+5.2 VOLT SUPPLY POSITIVE SENSE +5.2 VOLT SUPPLY POSITIVE SENSE UNREGULATED SUPPLY TO +5V	POWER SUPPLY POWER SUPPLY POWER SUPPLY	+5.2V 0V +7V TO +9V
+5.2V	REGULATED +5.2 VOLT SUPPLY	POWER SUPPLY	+5.2V

A62 Motherboard Component Level Troubleshooting

Table A62-1. Motherboard Wiring List

Mnemonic	Source	Destination
WSPAT WSPTM WYOKW WYTMCTL WYTMSLP W11R2	XA59-84 XA59-28 XA59-99 XA27-14 XA27-44 XA27-15	XA58-84 XA58-28 XA54-6 XA28-8 XA28-30 XA23-15
YO COIL + YO COIL - YO TUNE YOXISTB	XA55-15,30 A62J2-8.13 XA55-24 XA55-29	A62J2-6,15, A62J29-5 SEPARATE TRACE TO -40V SENSE POINT A62J6 SMC CENTER A62J29-4
Z-AXIS BLANK	XA57-97	A62J31-2,20
1 4V/GHZ 20/30 SWP 500 KHZ REF 8410 TRIG	XA28-7 XA58-41 XA42-9 XA57-62	XA24-6 XA43-1 XA41-20 A62J31-7
+1.0 V/GHZ +1.0 V/GHZ RTN +5V AC1	XA28-17 XA28-39 A62 LUG 5	A62J31-31,32 A62J31-13 XA35-8,9,10,26,27,28, T1 GREEN WIRE
+5V AC2	A62 LUG 5	XA35-12,13,14,30,31,32, T1 GREEN WIRE, A62CR1 ANODE
+5V SENSE(+) +5V SENSE(-) +5V UNREG	XA52-15 XA52-39 XA35-1, 2, 3, 19, 20, 21	TO TRACE ON A62 NEAR XA52-17, +5.2 VOLT SENSE POINT TO A62 STAR GROUND ^e XA52-13,14,37,38, A62C2(+), A62C3(+), THRU A62R3 TO GND
+5.2V	XA52-17,18,41,42	XA21-5,23, XA22-2,20 ^g , XA23-3,21, XA24-3, XA25-6,28, XA26-4,26, XA27-3,34, XA28-2,24, XA34P2-4,5, THRU A62L1 TO XA36-15,30, THRU A62L3 TO XA37-18,36, THRU A62L7 TO XA39-15,30, XA40-15,30, XA41-15,30, XA42-18,36, XA43-18,36, XA54-2,20, XA55-2,17, XA57-36,37,92, XA58-36,37,92. XA59-36,37,92. XA60-36,37,92. XA61-36,37,92 ^h , A62J1- 31 THRU 37, A62J2-4,17, A62J19-3,11, A62J31-3

^e M/N assembly ground plane connected to Star Ground through W45.

^g Reserved for future expansion.

^h The A61 board assembly is not included with the HP 8340B. Traces connected to XA61 are included in this wiring list to keep signal destinations complete.

A62 Motherboard Component Level Troubleshooting

Table A62-1. Motherboard Wiring List

Mnemonic	Description	Type	Levels
+12V	REGULATED +12 VOLT SUPPLY	POWER SUPPLY	+12V
+12V UNREG +12V U1 ADJ	UNREGULATED SUPPLY TO +12V +12V REGULATOR ADJUSTMENT TERMINAL	POWER SUPPLY POWER SUPPLY	+20V +10 5V
+20V	REGULATED +20 VOLT SUPPLY	POWER SUPPLY	+20V
+20V AC1 +20V AC2 +20V REF OSC +20V UNREG	TRANSFORMER SECONDARY FOR +20V SUPPLY TRANSFORMER SECONDARY FOR +20V SUPPLY SWITCHED +20V SUPPLY TO 10 MHZ REF. UNREGULATED SUPPLY TO +20V	POWER SUPPLY POWER SUPPLY POWER SUPPLY POWER SUPPLY	26.4 VAC 26.4 VAC 0V/+20V +31.2V
+22V -.25V/GHZ -5.2V -7V REF -10V	REGULATED +22 VOLT SUPPLY - 25 VOLTS/GHZ OUTPUT FREQUENCY REGULATED -5.2 VOLT SUPPLY -7V REFERENCE SUPPLY REGULATED -10 VOLT SUPPLY	POWER SUPPLY POWER SUPPLY POWER SUPPLY POWER SUPPLY POWER SUPPLY	+22V -.25V/GHZ -5.2V -7V -10V
-10V AC1	TRANSFORMER SECONDARY FOR -10V SUPPLY	POWER SUPPLY	13.9 VAC
-10V AC2	TRANSFORMER SECONDARY FOR -10V SUPPLY	POWER SUPPLY	13.9 VAC
-10V RTN	-10V SUPPLY SERIES PASS COLLECTOR	POWER SUPPLY	+6.4V AT 13.3 GHZ
-10V UNREG	UNREGULATED SUPPLY TO +10V	POWER SUPPLY	-10V

A62 Motherboard Component Level Troubleshooting

Table A62-1. Motherboard Wiring List

Mnemonic	Source	Destination
+12V +12V UNREG +12V U1 ADJ	XA52-9,33 XA52-11,35 XA52-10	XA23-2,20, XA57-91, XA58-91, XA59-91, XA60-91, XA61-91 ¹ , A62J1-2, A62CR3 CATHODE, A62U1 CASE A62U1-1, A62C7(+) A62C6(+), A62CR3 ANODE, THRU A62R4 TO GND, A62U1-2
+20V	XA52-16,40	XA21-4,22, XA22-1.19 ⁹ , XA23-1.19, XA24-1, XA25-5,27, XA26-3, XA27-2,33, XA28-1,23, XA34P2-2,3, THRU A62L2 TO XA36-13,28, THRU A62L5 TO XA38-13,28, XA40-13,28, XA41-13,28, XA42-16,34, XA43-16,34, XA52-16,40 (+20V SENSE POINT), XA53-29, XA54-1, XA55-1,16, XA57-35,90, XA58-35,90, XA59-35,90, XA60-35,90, XA61-35 ¹ , A62J2-9,12, A62J18-6, A62J19-2,10
+20V AC1 +20V AC2 +20V REF OSC +20V UNREG	A62 LUG 2 A62 LUG 2 XA52-20 XA35-7,25	XA19-1,13, T1 RED WIRE XA19-2,14, T1 RED WIRE A62J3-1 XA19-9,21, XA52-23,24,47,48
+22V -25 V/GHZ -5.2V -7V REF -10V -10V AC1	XA35-18,36 XA28-40 XA53-18,36 XA43-9 XA53-12,13,31,32 A62 LUG 6	XA60-88, XA61-90 ¹ , A62CR2 CATHODE, A62J1-30, A62J3-5, A62K1-2 XA25-38, XA27-51 XA23-4, XA27-1,32, XA34P2-12,13, XA52-22, XA57-93, XA58-93, XA59-93, XA60-93, XA61-93 ¹ , A62J1-42, A62J2-1,20, A62J19-4,12 XA41-7 XA21-7,25, XA22-4,22 ⁹ , XA23-5,23, XA24-5, XA25-7,29, XA26-5,27, XA27-4,35, XA28-3,25, XA34P2-8,9, THRU A62L8 TO XA36-12,27, THRU A62L4 TO XA38-12,27, THRU A62L6 TO XA39-12,27, XA40-12,27, XA41-12,27, XA42-15,33, XA43-15,33, XA54-4,22, XA55-4,19, XA56-4,19, XA57-39,94, XA58-39,94, XA59-39,94, XA60-39,94, XA61-39,94 ¹ , A62J2-10,11, A62J18-7, A62J19-5,13 XA19-3,4,15,16, T1 BLUE WIRE
-10V AC2	A62 LUG 6	XA19-5,6,17,18, T1 BLUE WIRE
-10V RTN	XA53-2,20	XA19-7,8,19,20, A62Q1 COLLECTOR
-10V UNREG	XA19-11,12,23,24	XA53-9,10,27,28

⁹ Reserved for future expansion.

¹ The A61 board assembly is not included with the HP 8340B. Traces connected to XA61 are included in this wiring list to keep signal destinations complete.

Table A62-1. Motherboard Wiring List

Mnemonic	Description	Type	Levels
-15V -40V	REGULATED -15V SUPPLY REGULATED -40V SUPPLY	POWER SUPPLY POWER SUPPLY	-15V -40V
-40V AC1 -40V AC2	TRANSFORMER SECONDARY FOR -40V SUPPLY TRANSFORMER SECONDARY FOR -40V SUPPLY	POWER SUPPLY	42.8 VAC 42.8 VAC
-40V RTN -40V SENSE (+) -40V SENSE (-) -40V UNREG	-40V SUPPLY SERIES PASS COLLECTOR -40V SUPPLY POSITIVE SENSE -40V SUPPLY NEGATIVE SENSE UNREGULATED SUPPLY TO -40V	POWER SUPPLY POWER SUPPLY POWER SUPPLY POWER SUPPLY	12.7V AT 13.3 GHZ 0V -40V -40V

A62 Motherboard Component Level Troubleshooting

Table A62-1. Motherboard Wiring List

Mnemonic	Source	Destination
-15V -40V	XA56-15,30 XA53-11,30	XA27-5,36, XA28-4, XA54-8, XA57-38, XA58-38, XA59-38, XA60-38, XA61-38 ¹ XA22-3,21 ¹ , XA23-7,25, XA28-5,27, XA34P2-6,7, XA40-11,26, XA53-11,30, XA54-3, XA55-3,18, XA56-3,18, A62J2-8,13, A62J19-6, A62C5
-40V AC1 -40V AC2	A62 LUG 4 A62 LUG 4	XA35-15,33, T1 YELLOW WIRE XA35-16,34, T1 YELLOW WIRE
-40V RTN -40V SENSE(+) -40V SENSE(-) -40V UNREG	XA53-3,22 XA53-5 XA53-23 XA35-6,24	XA35-5,23, A62C1(+), A62R2, A62Q2 COLLECTOR A62 STAR GROUND A62 -40V SENSE POINT XA53-6,24, A62C1(-), A62R2

¹ Reserved for future expansion.

² The A61 board assembly is not included with the HP 8340B. Traces connected to XA61 are included in this wiring list to keep signal destinations complete.

A62 Motherboard Component Level Troubleshooting

Table A62-2. HP 8340B Motherboard Coaxial Cables

Cable	Mnemonic/ Description	Type	Signal Level	Source	Destination
A62J12 CENTER A62J12 SHIELD	NOT USED NOT USED				XA23-36 XA23-35
A62J17 CENTER A62J17 SHIELD	FM INPUT A62 STAR GND	ANALOG GROUND	±8V 0V	J22 J22	XA23-18 XA23-17
A62J21 CENTER A62J21 SHIELD	NOT USED NOT USED				XA22-11 XA22-29
A62J22 CENTER A62J22 SHIELD	NOT USED NOT USED				XA22-10 XA22-28
A62J23 CENTER A62J23 SHIELD	NOT USED NOT USED				XA22-9 XA22-27
A62J24 CENTER A62J24 SHIELD	FM OUT FM OUT SHIELD	ANALOG GROUND	CURRENT SOURCE 0V	XA23-16 XA23-34	A44J3 A44J3

**HP 8340B
SYNTHESIZED SWEEPER
(Including Options 001, 004,
005, 006, and 007)**

**Component Level Service Manual
Volume 2**

SERIAL NUMBERS

This manual applies directly to the HP 8340B Synthesized Sweeper having a serial number prefix of 2812A.

For additional information about serial numbers prior to 2812A, refer to the BACKDATING section located at the back of Volume 2 of this manual.

© Copyright HEWLETT-PACKARD COMPANY 1987
1400 FOUNTAINGROVE PARKWAY, SANTA ROSA, CA 95403 U.S.A.

MANUAL PART NO. 08340-90245
Microfiche Part Number 08340-90246

Edition 2
Printed: APRIL 1988



**HEWLETT
PACKARD**

Component-Level Service Volume 2

CONTENTS

CONTROLLER F

- A57 Marker/Bandcross
- A59 Digital Interface
- A60 Processor

FRONT PANEL/REAR PANEL G

- A1 Alpha Display
- A2 Display Driver
- A3 Display Processor
- A5 Keyboard and A7 Lower Keyboard
- A6 Keyboard Interface
- Rear Panel Component-Level Information

RF SECTION H

- A20 RF Section Filter
- A21 Pulse Modulator
- A24 Attenuator Driver/Step Recovery Diode (SRD) Bias
- A25 ALC Detector
- A26 Linear Modulator
- A27 Level Control
- A28 SYTM Driver

POWER SUPPLIES I

- A19 Capacitor Assembly
- A35 Rectifier
- A52 Positive Regulator
- A53 Negative Regulator
- A56 -15V Regulator

MAJOR ASSEMBLIES AND COMPONENTS LOCATION - CHASSIS PARTS J

- Major Assemblies and Components Location
- Option Configurations

Controller Component-Level Service F

CONTENTS

A57 MARKER/BANDCROSS

CIRCUIT DESCRIPTION	A57-1
Assembly Purpose	A57-1
Sweep Event Detection (Blocks A, B, C, D, E, and F)	A57-1
Address Register (Block A)	A57-2
Sweep Event Memory (Block B)	A57-3
Read/Write Ram Buffer (Block C)	A57-3
Sweep Comparator (Block D)	A57-3
Ram Data Unstable Timer (Block E)	A57-3
Marker/Bandcross Flip-Flops (Block F)	A57-4
Manual Sweep Dac (Block G)	A57-4
Sweep Outputs (Block H)	A57-4
Read Status Buffer (Block I)	A57-4
Control Register (Block J)	A57-4
Microprocessor Read and Write Strokes (Block K)	A57-5
Sweep Trigger (Block L)	A57-5
Stop Sweep Control (Block M)	A57-6
CRT Z-Axis Control (Block N)	A57-6
Interface Signals	A57-6
TROUBLESHOOTING	A57-8
How to Check the Microprocessor I/O Address Strokes	A57-8
How to Check the Microprocessor Output Devices	A57-8
How to Check the Microprocessor Input Devices	A57-8
How to Check the Sweep Detection Circuits (Blocks A through F)	A57-9
How to Troubleshoot Blocks G through N	A57-13
A57 Marker/Bandcross P1 Pin I/O	A57-14
A57 Marker/Bandcross Component Location Diagram	A57-18
A57 Marker/Bandcross Schematic Diagram	A57-19
A57 Marker/Bandcross Replaceable Parts	A57-21

A59 DIGITAL INTERFACE

CIRCUIT DESCRIPTION	A59-1
Assembly Purpose	A59-1
Microprocessor Read/Write Strobe (Block A)	A59-1
Phase Lock Indicators and Control (Block B)	A59-2
Change Detector (Block C)	A59-2
M/N Control (Block E)	A59-3
Miscellaneous Inputs (Block F)	A59-3
Miscellaneous Control (Block G)	A59-3
Processor Service Requests (Block H)	A59-4

CONTENTS (Cont'd)

TROUBLESHOOTING	A59-5
Checking the Microprocessor I/O Address Strokes (Block A)	A59-5
Checking Microprocessor Output Devices (Blocks B, E, and G)	A59-5
Checking Microprocessor Input Devices (Blocks F and H)	A59-6
Change Detectors (Block C)	A59-6
Processor Service Request (Block H)	A59-6
A59 Processor P1 Pin I/O	A59-8
A59 Digital Interface Component Location Diagram	A59-12
A59 Digital Interface Schematic Diagram	A59-13
A59 Digital Interface Replaceable Parts	A59-15

A60 PROCESSOR

CIRCUIT DESCRIPTION	A60-1
Assembly Purpose	A60-1
Memory (Blocks A, B, and C)	A60-2
Timer/Self Test Indicator/DSA (Block D)	A60-2
I/O Decoding and Control (Block E)	A60-2
Self Test (Block F)	A60-2
Power Supplies (Block G)	A60-3
Memory Decoding (Block H)	A60-3
Clock (Block I)	A60-3
Interrupt Encoder (Block J)	A60-3
Processor (Block K)	A60-5
Free Run DSA (Block L)	A60-5
HP-IB Interface (Block M)	A60-5
I/O Data Bus Buffers (Block N)	A60-6
Power Up/Stop (Block O)	A60-8
I/O Address Bus (Block P)	A60-8
TROUBLESHOOTING	A60-9
Types of Troubleshooting	A60-9
Input Signal Verification	A60-9
Self Tests	A60-11
A60 Processor Self Test LEDs	A60-13
Shift M4	A60-15
Destructive RAM Test	A60-19
HP-IB Verification	A60-20
Battery Replacement	A60-20
A60 Processor P1 Pin I/O	A60-22
A60 Processor Component Location Diagram	A60-26
A60 Processor Schematic Diagram	A60-27
A60 Processor Replaceable Parts	A60-31

A57 Marker/Bandcross Circuit Description

ASSEMBLY PURPOSE

The A57 marker/bandcross assembly generates the z-axis signal required to place intensity markers on an external CRT. If enabled, amplitude markers are generated by sending a marker signal to the leveling circuits. The same circuits that detect markers are used to detect band crossings or the end of sweep. These circuits both cause the sweep to stop and activate the microprocessor. Other circuits interface with the rear panel connections. During self test, hardware on this assembly verifies that the 16-bit microprocessor data bus is operating.

The sweep-event memory stores numbers that correspond to voltages on the 0-10V sweep signal. Each number stored in the memory represents a single sweep event. Sweep events are detected by the sweep comparator, which compares them against the 0-10V sweep ramp. Sweep events include:

- Turning markers on and off
- Stopping the sweep for a bandcrossing
- Stopping the sweep for the end-of-sweep and retrace

The sweep comparator DAC also finds the current sweep position when you make changes in frequency parameters during an analog sweep longer than 300 ms.

The manual sweep DAC offsets the sweep-out signal when the instrument is in CW or manual mode.

The sweep control block allows the sweep to be stopped either from the rear panel, or by the sweep comparator. With the CRT Z-axis control circuits, the sweep can be blanked on a display for bandcrossing or retrace, and markers can be intensified.

The A57 marker/bandcross assembly uses the LBX (low bandcross) signal to stop the analog sweep at positions previously loaded in the sweep event memory by the microprocessor. When LBX is low, the A59 digital interface causes the microprocessor to run, allowing the microprocessor to perform the tasks necessary for the sweep to proceed. This happens either at a bandcrossing, or at retrace at the end of a sweep.

SWEEP EVENT DETECTION (BLOCKS A, B, C, D, E, and F)

A Sweep Event and How it's Loaded

A sweep event is a marker, a band crossing, or the end of sweep. Prior to the beginning of a sweep, the microprocessor stores (in the sweep event memory, block B) a series of numbers that correspond to all the sweep events to take place during that sweep. The numbers load as follows:

1. The microprocessor sets the address register (block A) to 0 (i.e. sets data bits zero through six to 0, and outputs address 12,R3:).
2. The microprocessor writes a series of numbers into the sweep event memory (block B) that correspond to the upcoming sweep events. The address register (block A) automatically increments after each write to memory.
3. The microprocessor sets the address register (block A) back to 0.

How the Number and Position of Sweep Events are Determined

Before a sweep begins, the microprocessor determines the number of sweep events. For example, for a sweep having one bandcrossing and one marker, there are four sweep events:

1. Beginning of marker
2. End of marker
3. Bandcrossing
4. End of sweep

After determining the number of sweep events, the microprocessor computes the point in the sweep that each event occurs, and converts this information to a number from 0 to 999 that corresponds to the 0 to 10V sweep.

How Sweep Events are Executed

The series of numbers that defines the location of sweep events is written into the sweep event memory (block B) via data lines B0 through B9. When the address register (block A) is set to location 0, the first number stored in memory appears at the input of the sweep comparator DAC (block D). The DAC converts this number to a voltage between 0 and 10V. This voltage does not appear at the DAC output, but is compared internally to the marker ramp (MKR RMP) 0 to 10V signal. When the MKR RMP rises to the voltage to which the DAC is set, the DAC fires a comparator and the first sweep event occurs.

When the first sweep event occurs, the marker and bandcross flip flops (block F) are clocked, and their data (taken from data bits 10 and 11 of the RAM) determine the type of sweep event. Two sweep events create a marker; the first event turns the marker on, and the second turns it off. Markers are 2/1000 of the display width.

What Happens when You Change Sweep Parameters

If you change a frequency parameter in the middle of a slow sweep (300 ms or longer), the sweep event detection circuitry (blocks A through F) determines the position of the sweep, and allows the instrument to phase-lock to a frequency appropriate to that sweep position. For faster sweep times, the instrument waits until the beginning of the next sweep to make frequency changes.

ADDRESS REGISTER (BLOCK A)

Counter Register

A 6-bit counter register presets when the microprocessor writes to I/O address 12,R3:

Address Register

The address register is counted or incremented in one of two ways:

- The microprocessor writes to I/O address 12,R0.
- RAM data timer (block E)

The timer signals that a sweep event has occurred and tells the sweep event detection circuitry (blocks A through F) to get ready for the next sweep event.

The address register outputs (A0 through A6) are used to address the sweep event memory (block B).

SWEEP EVENT MEMORY (BLOCK B)

Each RAM contains 128 8-bit bytes, which are combined to provide 128 16-bit words of memory. Sweep events are stored in RAM when the microprocessor writes to I/O address 12,R0. In normal operation, approximately 15 words of memory are used for a full-band sweep with all five markers on, each location corresponding to the position and type of a single sweep event.

READ/WRITE RAM BUFFER (BLOCK C)

Bidirectional Buffer

A 16-bit bidirectional buffer connects the microprocessor with the sweep event memory (block B). When the microprocessor sends I/O address 12,R0, the buffer transfers data from the instrument data bus (DB0 through DB15) to B0 through B15.

When the microprocessor sends I/O address 12,R2, data is transferred in the opposite direction, i.e. from the sweep event memory to the microprocessor.

SWEEP COMPARATOR (BLOCK D)

Digital-to-Analog Converter (DAC)

The output of a 10-bit DAC is compared to the 0-to-10V MKR RMP (marker ramp). At the beginning of a sweep, the DAC output is below 0V. When the voltage applied by the MKR RMP equals the digital number at the DAC input, the output goes above 0V.

Comparator

A comparator trips when the DAC output rises above 0V. Two feedback resistors provide a 2 mV offset to the positive input of the comparator to ensure that it does not change states due to noise on the MKR RMP.

10V End of Sweep Adjust

Use the 10V END of SWP ADJ (R32) to set the end of sweep voltage to 10.000V.

RAM DATA UNSTABLE TIMER (BLOCK E)

This circuit debounces the sweep comparator output (block D) and increments the address register (block A) after each sweep event is detected.

MARKER/BANDCROSS FLIP-FLOPS (BLOCK F)

Control signals from the sweep event memory (block B) indicate the type of sweep event. At a bandcrossing, the sweep stops so that the microprocessor can initiate phase-lock for that bandcrossing (with the low bandcross signal, LBX). At a marker, however, the sweep does not stop; the marker is generated as the sweep continues.

MANUAL SWEEP DAC (BLOCK G)

The manual sweep DAC is used only in the MANUAL SWEEP mode. In this mode, MKR RAMP is 0V. SWEEP OUT results from either the manual sweep DAC (when MANUAL SWEEP is selected), or the MKR RAMP (when MANUAL SWEEP is not selected).

Manual Gain (MAN GAIN)

In MANUAL SWEEP, with the frequency set to the maximum possible value for a given sweep (the STOP frequency), the manual gain adjustment (R33) is used to set 10.000V at the sweep output.

SWEEP OUTPUTS (BLOCK H)

SWEEP OUT is buffered by two operational amplifiers that are connected to the front and rear panel sweep output connectors. These operational amplifiers sense and remove unwanted low frequency noise on the output connectors.

READ STATUS BUFFER (BLOCK I)

Reading from I/O address 12.R1, the microprocessor can (using the READ STATUS BUFFER) monitor the state of the following signals:

- The sweep comparator (CMP)
- The marker flip-flop (MKR)
- The high sweep (HSP) line

CONTROL REGISTER (BLOCK J)

The control register enables the microprocessor to directly control the state of the various interface lines connected to the register by writing data to I/O address 13.R3.

Marker Generation

An AND gate controls the RF marker signal (HMRKR). When this signal is high, the RF power control circuits slightly decrease the RF power to create a marker.

MICROPROCESSOR READ and WRITE STROBES (BLOCK K)

The instrument microprocessor outputs I/O address information on the I/O address bus (ADR0 through ADR4, and SIOA). The decoder decodes the address information and generates the appropriate strobe.

Strobes

The strobes generated by the decoder are used throughout this assembly either to clock registers (causing them to store data found on the I/O data bus), or to enable buffers to place data on the I/O data bus for the microprocessor to read

SWEEP TRIGGER (BLOCK L)

Multiplexer

A multiplexer selects either LINE or EXT trigger when the microprocessor outputs the appropriate bits to the instrument data bus (DB10 through DB13).

Shift Register

The shift register enables the appropriate multiplexer input (pin 7 high selects line trigger, pin 5 high selects external trigger). The register also disables the RAM Data Unstable Timer (block E).

The shift register also controls the ZON (Z-axis on) line. When this signal is high, the Z-AXIS output (block N) is forced to +5V.

3-to-8 Decoder

The 3-to-8 decoder generates 500 ns pulses each time the microprocessor writes to I/O address 13,R1:. By writing the appropriate numbers to this register, one of the following happens.

- The sweep starts
- The sweep stops
- Trigger enable
- The marker bandcross flip-flop clears

Stop Sweep

The output flip-flop controls the end of sweep. When the output is low, the sweep stops. If the sweep is already stopped, the STOP SWEEP signal inhibits new sweeps.

STOP SWEEP CONTROL (BLOCK M)

Stopping the Sweep

The sweep is stopped when.

- The bandcross signal (LBX) is applied from:
 - a. Sweep Event Detection (block F)
 - b. The sweep generator assembly. This **only** happens if the marker/bandcross assembly fails to stop the sweep before it reaches 12V.
- The microprocessor tells the Sweep Trigger (block L) to stop
- The LSSP (low stop sweep) rear panel BNC is held low.

Low Stop Sweep (LSSP)

LSSP is an IN/OUT signal. As an input signal, it prevents HSP (high sweep) from going high when LSSP is low. HSP goes to all devices in the instrument that need to respond to the sweep starting and stopping. As an output signal, LSSP is active high.

CRT Z-AXIS CONTROL (BLOCK N)

The Z-AXIS signal is used to drive the Z-axis input of a CRT display.

Beam Intensity

When this signal is 0V, the display turns its beam on with normal brightness.

When this signal is +5V, the display turns the beam off (blanks).

When this signal is -5V, the display intensifies the beam.

The Z-AXIS signal can be used to turn the display off for bandcrossings, when the sweep is reset (sweep retrace), or at other times when the instrument is waiting for a sweep to start. Z-AXIS can also be used to show markers by brightening the display at that point on the trace.

INTERFACE SIGNALS

When the synthesizer is connected to the following equipment, the signals listed below are required from this assembly:

HP 8410B Interface

- 0-to-10V SWEEP (drives display X-axis)
- STOP SWP (allows the HP 8410B to stop the sweep)
- NEG BLANK (for display blanking)
- Z-AXIS (to generate markers on the display)
- HP 8410 EXT TRIG (to initiate HP 8410 phase lock when the synthesizer phase locks)

HP 8755C Interface

- 0 to 10V SWEEP (drives display X-axis)
- Z-AXIS (controls blanking and marker generation)
- L ALTEN (low indicates alternate mode enabled)
- L ALTSEL (low indicates alternate state active)
- L RETRACE (low indicates retrace used to synchronize with the start of sweep).

Plotter Interface

- MUTE (to freeze the servo for bandcrossings)
- PEN LIFT (to raise the pen for retrace and, optionally, for bandcrossings)
- 0 to 10V SWEEP (to drive the X-axis)

A57 Marker/Bandcross Component-Level Troubleshooting

HOW TO CHECK THE MICROPROCESSOR I/O ADDRESS STROBES

U28 (block K) is connected to the I/O address bus, and generates all the I/O strobes used on this assembly. You can check the strobes on the output of U28 using the front panel to write directly to U28's I/O address while monitoring its outputs:

1. Press **[INSTR PRESET] [MANUAL]**
2. Connect a logic probe to the output you wish to check.
3. At the front panel, enter the corresponding I/O address (from the schematic).

Example: Address 12,R0: (WRITE RAM) is entered:

[SHIFT] [GHz] [1] [2] [Hz] (the channel)
[SHIFT] [MHz] [0] [Hz] (the subchannel)
[SHIFT] [KHz] (makes the entry)

4. Make entries by pressing the step keys, using the front panel knob, or using the data pad. Each entry generates an active low signal, approximately 500 ns wide, that you can monitor with the logic probe, or see on a storage oscilloscope. Refer to COMPONENT LEVEL SERVICE, in volume 1 for more information on direct I/O addressing.

HOW TO CHECK THE MICROPROCESSOR OUTPUT DEVICES

The following are microprocessor output devices.

U1 (block A)	U17 (block G)
U8 (block C)	U18 (block L)
U9 (block G)	U23 (block J)
U10 (block A)	U25 (block L)
U16 (block C)	

These can be checked using direct I/O addressing, as described above.

HOW TO CHECK THE MICROPROCESSOR INPUT DEVICES

The following are microprocessor input devices.

U8 (block C)
U16 (block C)
U24 (block I)

These can be checked using direct I/O addressing. After setting the address, press **[SHIFT] [Hz]**. Each time you press **[Hz]**, the instrument reads from the addressed device and displays the results in the entry display, in both decimal and octal formats. To check each input, monitor the outputs and short DB0 to DB15 to +5V or ground.

HOW TO CHECK THE SWEEP DETECTION CIRCUITS (BLOCKS A THROUGH F)

Verify the Problem is in Blocks A through F

1. Press [INSTR PRESET] [SWEEP TIME] [2] [0] [SEC] [SHIFT] [M2].
2. Check the front panel POWER dBm display. It should indicate the band number as the instrument goes from band to band.

If the number is not changing, LBX (low bandcross; block F) is not being generated.

If the numbers count rapidly from 1 through 5, LBX is not being pulled low, as it should be when the sweep progresses.
3. Check that the front panel green SWEEP LED goes out at band crossings.

How to Check the Sweep Event Detection Circuitry

1. Press [INSTR PRESET]
[START] [3] [GHz]
[STOP] [6] [GHz]
[M1] [4] [GHz]
[M2] [5] [GHz]
[MKR Δ] [1]
2. Using an oscilloscope, monitor the sweep output and the Z-axis signal. The sweep output should stop at 10V before it is reset for the next sweep. If the sweep goes to 12V, there is a problem in block F.
3. Check the Z-axis signal to see if the delta marker is on for the middle portion of the sweep. Turn off the delta marker and see if two markers are indicated by the Z-axis signal.
4. U6 pin 7 should have a pulse for each sweep event. If not, slow the sweep to 200s and turn all markers off. Measure the inputs of U3 to see if the binary number input is correct [decimal = 1000, binary = (bit 10) 1 1 1 1 0 1 0 0 0 (bit 0)]. this number represents a 10V set point for the comparator.
5. Check the RAM Data Unstable Timer (block E) for the 5.7 μs and 200 ns pulse widths:

Press [INSTR PRESET].
Clock an oscilloscope on the CMP signal (block D, U6 pin 7).
6. If you suspect U2 and U15, check A0 through A6 using digital signature analysis (refer to I/O data test in the A60 processor assembly troubleshooting). If the signatures are incorrect, make sure that the RAM Data Unstable Timer (block E) is not clocking the address register. Disable this by placing the instrument in MANUAL mode while performing the test.

How to Troubleshoot Blocks A through F

Block D:

1. Press [INSTR PRESET] [VF] [1] [Mz] [SWEEP TIME] [1] [0] [SEC].
2. Check that U3 pin 16 has a 10s, 0 to 10V ramp
3. Check that the B9 through B0 inputs of DAC U3 read.
(B9) 1 1 1 1 1 0 1 0 0 0 (B0)

NOTE: 1 = TTL high

4. Check U3 pin15. It should be below 0V until the sweep gets to 10V. As the sweep rises above 10V, the voltage at pin 15 should rise above 0V, and comparator U6 should fire, forcing CMP (U6 pin 7) high for approximately 50 ms.

Block E:

1. Press [INSTR PRESET] [VF] [1] [MHz].
2. Using an oscilloscope, trigger on the rising edge of CMP (U6 pin 7). Check that U5B has a 700 ns positive pulse at pin 5, and an inverted, identical pulse at pin 12.
3. Check that each time U5B fires, U5A also fires, creating a 5.7 μ s positive pulse at U5A pin 13
4. Check that U5B pin 11 is not stuck low. It should go low only when the synthesizer is not sweeping.

Block F:

1. Press [INSTR PRESET]
[START] [1] [GHz]
[STOP] [1] [3] [GHz]
[SWEEP TIME] [1] [0] [0] [msec]
[M1] [8] [GHz]
[M2] [1] [1] [GHz]
[MKR Δ]
2. U11B pin 9 (MKR) should repetitively be high for 30 ms, then low for approximately 100 ms.
3. U11A pin 5 should go high for approximately 50 ms when TP5 (SWEEP OUT) reaches approximately 4V. When TP5 reaches 10V, there should be another 50 ms pulse
4. U11A pin 1 should have a single 500 ns pulse applied by U25 block L) at the end of each sweep. If not, check U25 using direct I/O addressing.

Block C:

Bidirectional buffers U8 and U16 are thoroughly verified by the instrument preset/ power on tests. If the instrument front panel check LED II is off, the buffers are good. Use direct I/O addressing to verify that data can be sent from DB0-DB15 to B0-B15. To verify the other direction (B0-B15 to DB0-DB15):

1. Press **[INSTR PRESET] [SINGLE]** sweep.
2. Do a read from address 12,R2: (reads sweep event from RAM):
 - a. Press **[SHIFT] [GHz]**.
 - b. Enter address **[1] [2]** and press any terminator (**[GHz]**, **[MHz]**, **[kHz]**, or **[Hz]**).
 - c. Press **[SHIFT] [MHz]**.
 - d. Enter subchannel **[2]** and press any terminator.
 - e. Read (press **[SHIFT] [Hz]**).

NOTE: You can control the synthesizer bandcross selection as follows:

Enable: **[SHIFT] [MHz] [2] [3] [Hz] [SHIFT] [kHz] [0] [Hz]**
 Advance: **[SHIFT] [MHz] [2] [2] [Hz] [SHIFT] [kHz] [0] [Hz]**
 Disable: **[SHIFT] [MHz] [2] [4] [Hz] [SHIFT] [kHz] [0] [Hz]**

3. The entry display should show an octal number and its decimal equivalent. Convert the octal number to a binary number. This is the number that should be on B0 through B15.

For B0 through B15 to be correct, the SWEEP EVENT MEMORY must have been properly loaded with this number. This is done through U8 and U16. First check that U8 and U16 can transfer data from the instrument data bus to the marker bandcross bus.

Before replacing U8 or U16, verify that the two I/O strobes 12,R2: and 12,R0: are generated by U29 (block K). If the problem only involves a few bits, the self test LEDs on the A60 processor assembly can be used to indicate which bits are incorrect. If all LEDs are on, the problem may have to do with blocks A, B, E, or K.

Block A:

1. Press **[INSTR PRESET] [SINGLE]** sweep
[SHIFT] [MHz] [2] [3] [Hz] [SHIFT] [kHz] [0] [Hz]
[SHIFT] [GHz]
[1] [2] [Hz]
[SHIFT] [MHz]
[3] [Hz]
[SHIFT] [kHz] (write)
[0] [Hz]

This should clear U1 and U10. Verify that lines A0 through A6 are low.

- Using the front panel, enter

[1], [2], [4], [8], [1] [6], [3] [2], [6] [4]

These entries should latch into U1 and U10, and appear on the A0 through A6 lines.

Example: When you enter 16, the A bus should read

(A6) 0 0 1 0 0 0 0 (A0)

- Press [0] [Hz]
[MHz] [0] [Hz]

The A bus lines should be all low. Note that each time you press a [STEP] key, the number on the A bus increments by 1.

0 = (A6) 0 0 0 0 0 0 0 (A0)

32 = (A6) 0 1 0 0 0 0 0 (A0)

15 = (A6) 0 0 0 1 1 1 1 (A0)

U29B pin 5 should be high throughout this entire test. U29B pin 6 should follow U29B pin 4.

Block B:

Use direct I/O addressing to check that the READ/WRITE RAM BUFFER (block C) can place data on the B-BUS (B0 through B15). Check that U8 and U16 can read the B-BUS:

- Press [INSTR PRESET] [SINGLE] sweep
[SHIFT] [GHz]
[1] [2] [Hz]
[SHIFT] [MHz]
[2] [Hz]
[SHIFT] [Hz] to read
[SHIFT] [MHz] [2]
[SHIFT] [Hz]
- Alternately short each B-BUS line to +5V and ground. After each short, press [SHIFT] [Hz], and note that the octal number in the entry display indicates the appropriate bit forced high for shorts to +5V and low for shorts to ground.
- If all lines pass step 2, you can store and read back numbers in the SWEEP EVENT RAM as follows:

Press [INSTR PRESET]
[SHIFT] [MHz] [2] [3] [Hz] [SHIFT] [kHz] [0] [Hz]
[SHIFT] [SINGLE]
[SHIFT] [GHz]
[1] [2] [Hz]

- 4 Write to locations in RAM:

Press [SHIFT] [MHz]
 [3] [Hz]
 [SHIFT] [kHz]
 [a] [a] [a] [Hz] (aaa = RAM address from 0 through 127)

Press [SHIFT] [MHz]
 [0] [Hz]
 [SHIFT] [kHz]
 [d] [d] [d] [Hz] (ddd = data to be written to RAM)

It is only necessary to check through address 15. Verify that the numbers are properly stored in RAM:

Press [SHIFT] [MHz]
 [3] [Hz]
 [SHIFT] [kHz]
 [a] [a] [a] [Hz]
 [SHIFT] [MHz]
 [2] [Hz]
 [SHIFT] [Hz]

NOTE: aaa is the RAM address. The read data from the RAM is displayed in decimal and octal in the entry display. Verify that it matches the sequence of numbers entered.

HOW TO TROUBLESHOOT BLOCKS G THROUGH N

To check the Manual Sweep DAC (block G) and the Sweep Outputs (block H)

1. Put the instrument in MANUAL mode.
2. While monitoring the sweep outputs on the front or rear panel, turn the front panel knob and check that the voltage is 10V when the frequency is as high as possible, and 0V when the frequency is adjusted as low as possible. The voltage should be continuously variable between 10 and 0V.

To check the Sweep Trigger (block L) and the Control Register (block J)

1. Press [INSTR PRESET] [TIME] [2] [0] [sec]. Note that the sweep stops.
2. Provide an external trigger and verify that the green SWEEP LED is on during the sweep, and out momentarily for each bandcrossing and for the end of sweep.
3. Press the [EXT] trigger.
4. Verify that the instrument makes a complete sweep but does not continue to sweep.
5. Check the line trigger:

Press [ΔF] [1] [MHz]. Check that the sweep repetition rate is slower when in LINE trigger

A57 Marker/Bandcross Component-Level Troubleshooting

Table A57-1. A57 Marker/Bandcross P1 Pin I/O (1 of 3)

Pin	Mnemonic	Levels	Source	Destination
1 56	GND PLANE 0V GND PLANE	INSTRUMENT GROUND 0V	*O INSTRUMENT GROUND	*O
2 57	HMRKR LINE TRIG	TTL (HIGH TRUE) LINE FREQ 7 TO 10V	J A62-CR1 CATHODE/A62R1	XA26P1-43 L
3 58	LRETRACE	TTL (LOW TRUE)	J	F A62J31-11, 25
4 59	LALTSEL	TTL (LOW TRUE)	J	A62J31-10, 24
5 60	LALTEN	TTL (LOW TRUE)	J	A62J31-9, 23
6 61	MUTE	TTL (HIGH TRUE)	J	A62J31-8, 22
7 62	8410 TRIG	TTL	J	A62J31-7
8 63				
9 64				
10 65				
11 66				
12 67	HMRKR	TTL (HIGH TRUE)	J	XA26P1-43
13 68	HSP LINE TRIG	TTL (HIGH TRUE) LINE FREQ 7 TO 10V	M A62-CR1 CATHODE/A62R1	*I N L
14 69	LIPS LBX	TTL (LOW TRUE) TTL (LOW TRUE)	XA52P1-36/A62J1-19 *F	*NOT USED M XA59-69
15 70	SIOA GND PLANE	TTL (LOW TRUE) 0V	XA60P1-15 INSTRUMENT GROUND	*K *O
16 71	SIOB GND PLANE	TTL (LOW TRUE) 0V	XA60P1-16 INSTRUMENT GROUND	*NOT USED *O
17 72	ADR0 GND PLANE	TTL 0V	XA60P1-17 INSTRUMENT GROUND	*K *O
18 73	ADR2 ADR1	TTL TTL	XA60P1-18 XA60P1-73	*K *K
19 74	ADR4 ADR3	TTL TTL	XA60P1-19 XA60P1-74	*K *K

A single letter in the source or destination column refers to a function block on this assembly schematic

An asterisk (*) denotes multiple sources or destinations; refer to the A62 motherboard wiring list for a complete representation of signal sources and destinations

Table A57-1. A57 Marker/Bandcross P1 Pin I/O (2 of 3)

Pin	Mnemonic	Levels	Source	Destination
20 75	DB0 GND PLANE	TTL 0V	*C XA60P1-20 INSTRUMENT GROUND	*A C G J *O
21 76	DB2 DB1	TTL TTL	*C XA60P1-21 *C XA60P1-76	*A C G J *A C G J
22 77	DB4 DB3	TTL TTL	*C XA60P1-22 *C XA60P1-77	*A C G J *A C G J
23 78	DB6 DB5	TTL TTL	*C XA60P1-23 *C XA60P1-78	*A C G J *A C G J
24 79	DB8 DB7	TTL TTL	*C XA60P1-24 *C XA60P1-79	*C G *C G J
25 80	DB10 DB9	TTL TTL	*C I XA60P1-25 *C XA60 1-80	*C L *C G
26 81	DB12 DB11	TTL TTL	*C I XA60P1-26 *C I XA60P1-81	*C L *C L
27 82	DB14 DB13	TTL TTL	*C I XA60P1-27 *C I XA60P1-82	*C L *C L
28 83	DB15	TTL	*C I XA60P1-83	*C L
29 84	GND PLANE GND PLANE	0V 0V	INSTRUMENT GROUND INSTRUMENT GROUND	*O *O
30 85	GND PLANE GND PLANE	0V 0V	INSTRUMENT GROUND INSTRUMENT GROUND	*O *O
31 86	GND PLANE GND PLANE	0V 0V	INSTRUMENT GROUND INSTRUMENT GROUND	*O *O
32 87				
33 88				
34 89	GND PLANE GND PLANE	0V 0V	INSTRUMENT GROUND INSTRUMENT GROUND	*O *O
35 90	+20V +20V	+20V +20V	XA52P1-16, 40 XA52P1-16, 40	*O *O
36 91	+5.2V +12V	+5.2V +12V	XA52P1-17, 18, 41, 42 XA52P1-9, 33	*O *NOT USED
37 92	+5.2V +5.2V	+5.2V +5.2V	XA52P1-17, 18, 41, 42 XA52P1-17, 18, 41, 42	*O *O

A single letter in the source or destination column refers to a function block on this assembly schematic.

An asterisk (*) denotes multiple sources or destinations; refer to the A62 motherboard wiring list for a complete representation of signal sources and destinations.

A57 Marker/Bandcross Component-Level Troubleshooting

Table A57-1. A57 Marker/Bandcross P1 Pin I/O (3 of 3)

Pin	Mnemonic	Levels	Source	Destination
38 93	-15V -5.2V	-15V -5.2V	XA56P1-15, 30 XA53P1-18, 36	*0 *0
39 94	-10V -10V	-10V -10V	XA53P1-12, 13, 31, 32 XA53P1-12, 13, 31, 32	*NOT USED *NOT USED
40 95	GND PLANE	0V	INSTRUMENT GROUND	*0
41 96	NEG BLANK MKR RMP	0, +5V 0 TO 10V SWEEP	N XA58P1-96	A62J31-1, 15 D G
42 97	RFSWP Z-AXIS BLANK	10V/SWEEP +5V/-5V	H N	XA27P1-17 A62J31-2, 16
43 98	FPNLSWP	10V/SWEEP	H	A62J9-SMC CENTER
44 99	RPNLSWP FPNLSWP RTN	10V/SWEEP 0V	H H	A62J8-SMC CENTER
45 100	RGND RPNLSWP RTN	0V 0V	STAR GND POINT H	*0 *
46 101	RGND RGND	0V 0V	STAR GND POINT STAR GND POINT	*0 *0
47 102				
48 103				
49 104	HULH	TTL (HIGH TRUE)	A62J19-16	*NOT USED
50 105	HRFON	TTL (HIGH TRUE)	J	*
51 106	EXT TRIG	EXTERNAL SOURCE LEVEL	A62J31-4, 18	L A62J31-4, 18
52 107	LSSP	TTL (LOW TRUE)	M	A62J31-5, 19
53 108	PEN LIFT	CLAMP AT 56V	J	A62J31-6, 20
54 109	LSRQ PEN LIFT RTN	TTL (LOW TRUE) 0V	* J	*NOT USED A62J31-21
55 110	GND PLANE GND PLANE	0V 0V	INSTRUMENT GROUND INSTRUMENT GROUND	*0 *0

A single letter in the source or destination column refers to a function block on this assembly schematic.

An asterisk (*) denotes multiple sources or destinations; refer to the A62 motherboard wiring list for a complete representation of signal sources and destinations.

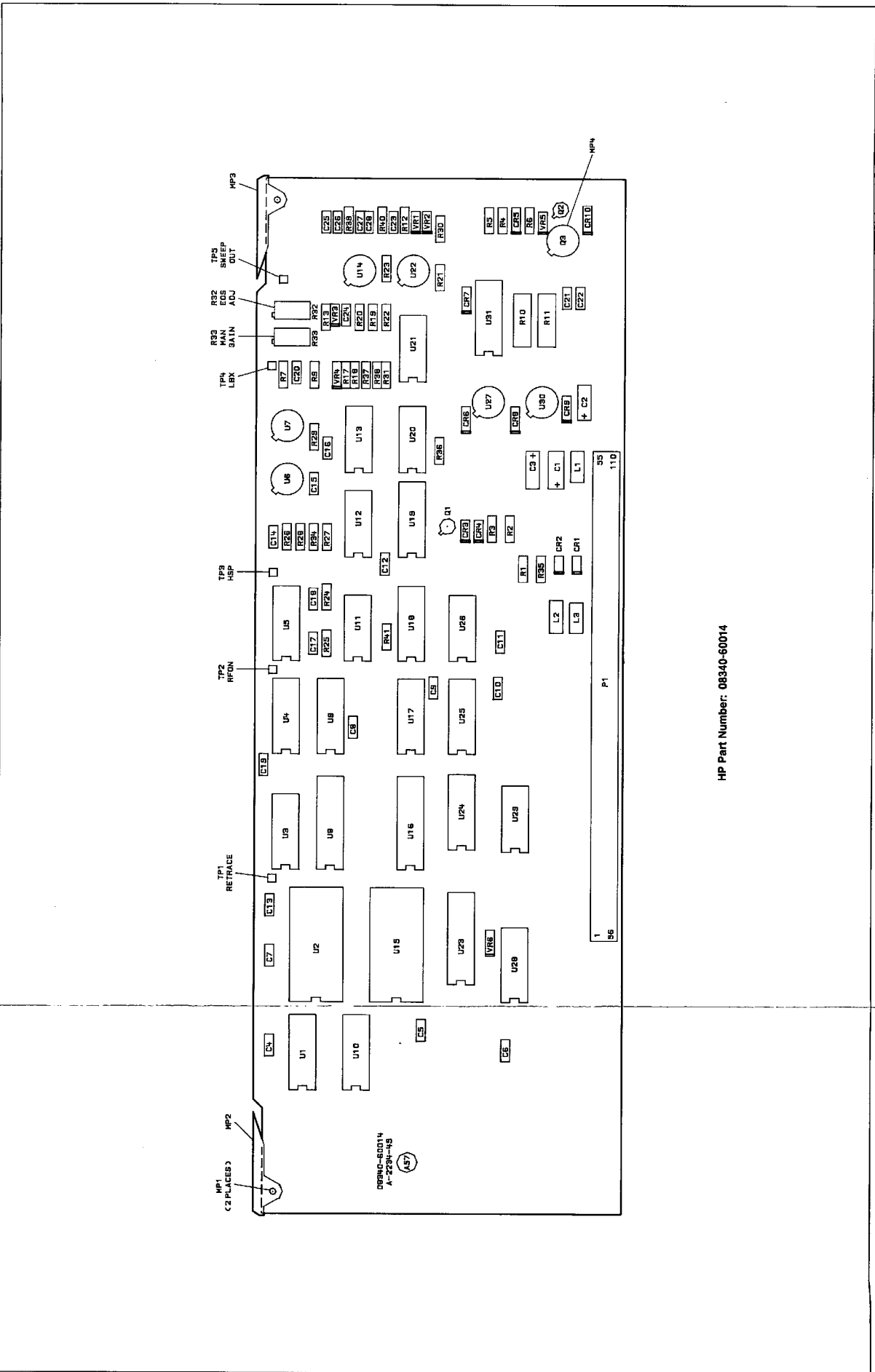

HP Part Number: 08340-60014

Figure A57-1. A57 Marker/Bandcross, Component Location Diagram
A57-18 Controller

**A57 MARKER/
BANDCROSS
(08340-6014)**

- PI-20 SWP
- PI-21 SWP
- PI-22 SWP
- PI-23 SWP
- PI-24 SWP
- PI-25 SWP
- PI-26 SWP
- PI-27 SWP
- PI-28 SWP
- PI-29 SWP
- PI-30 SWP
- PI-31 SWP
- PI-32 SWP
- PI-33 SWP
- PI-34 SWP
- PI-35 SWP
- PI-36 SWP
- PI-37 SWP
- PI-38 SWP
- PI-39 SWP
- PI-40 SWP
- PI-41 SWP
- PI-42 SWP
- PI-43 SWP
- PI-44 SWP
- PI-45 SWP
- PI-46 SWP
- PI-47 SWP
- PI-48 SWP
- PI-49 SWP
- PI-50 SWP
- PI-51 SWP
- PI-52 SWP
- PI-53 SWP
- PI-54 SWP
- PI-55 SWP
- PI-56 SWP
- PI-57 SWP
- PI-58 SWP
- PI-59 SWP
- PI-60 SWP
- PI-61 SWP
- PI-62 SWP
- PI-63 SWP
- PI-64 SWP
- PI-65 SWP
- PI-66 SWP
- PI-67 SWP
- PI-68 SWP
- PI-69 SWP
- PI-70 SWP
- PI-71 SWP
- PI-72 SWP
- PI-73 SWP
- PI-74 SWP
- PI-75 SWP
- PI-76 SWP
- PI-77 SWP
- PI-78 SWP
- PI-79 SWP
- PI-80 SWP
- PI-81 SWP
- PI-82 SWP
- PI-83 SWP
- PI-84 SWP
- PI-85 SWP
- PI-86 SWP
- PI-87 SWP
- PI-88 SWP
- PI-89 SWP
- PI-90 SWP
- PI-91 SWP
- PI-92 SWP
- PI-93 SWP
- PI-94 SWP
- PI-95 SWP
- PI-96 SWP
- PI-97 SWP
- PI-98 SWP
- PI-99 SWP
- PI-100 SWP

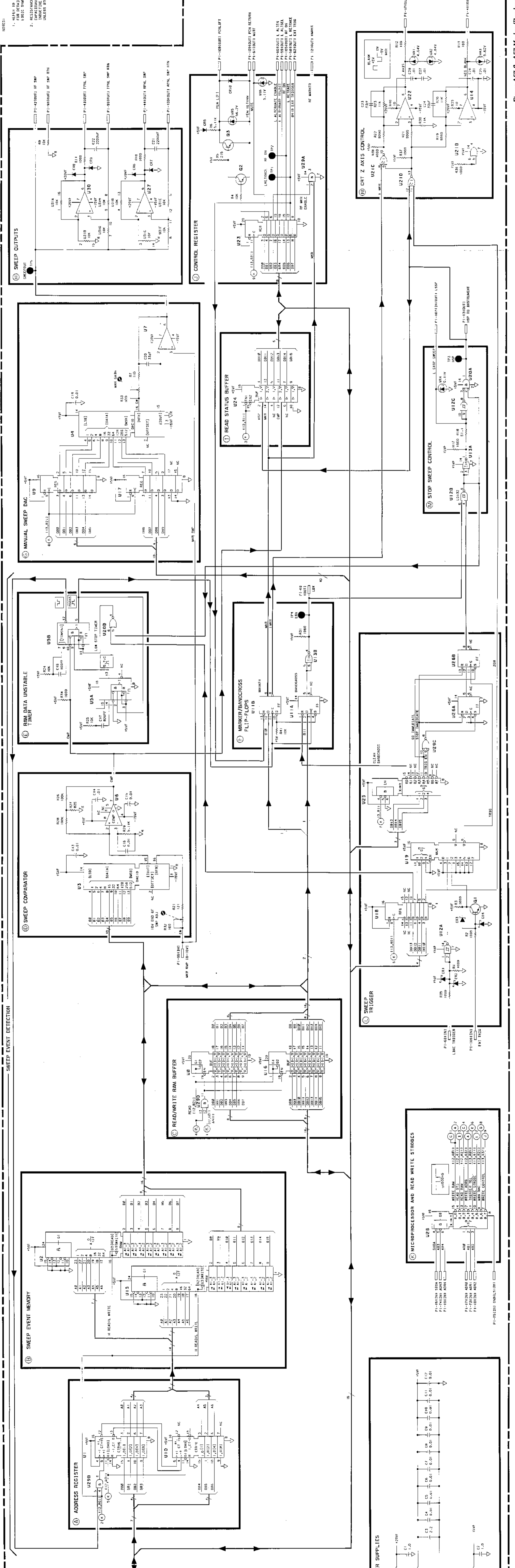

Figure A57-2. A57 Marker/Bandcross, Schematic Diagram
Controller A57-19/A57-20

A57 Marker/Bandcross Component-Level Troubleshooting

Table A57-2. A57 Marker/Bandcross Replaceable Parts

Reference Designation	HP Part Number	C D	Qty	Description	Mfr Code	Mfr Part Number
A57	08340-60014	5	1	MARKER/BANDCROSS ASSEMBLY	28480	08340-60014
A57C1	0180-0291	3	2	CAPACITOR-FXD 1UF ± 10% 35VDC TA	56289	150D105X9035A2
A57C2	0180-0291	3		CAPACITOR-FXD 1UF ± 10% 35VDC TA	56289	150D105X9035A2
A57C3	0180-0197	8	1	CAPACITOR-FXD 2.2UF ± 10% 20VDC TA	56289	150D225X9020A2
A57C4	0160-4832	4	18	CAPACITOR-FXD .01UF ± 10% 100VDC CER	28480	0160-4832
A57C5	0160-4832	4		CAPACITOR-FXD .01UF ± 10% 100VDC CER	28480	0160-4832
A57C6	0160-4832	4		CAPACITOR-FXD .01UF ± 10% 100VDC CER	28480	0160-4832
A57C7	0160-4832	4		CAPACITOR-FXD .01UF ± 10% 100VDC CER	28480	0160-4832
A57C8	0160-4832	4		CAPACITOR-FXD .01UF ± 10% 100VDC CER	28480	0160-4832
A57C9	0160-4832	4		CAPACITOR-FXD .01UF ± 10% 100VDC CER	28480	0160-4832
A57C10	0160-4832	4		CAPACITOR-FXD .01UF ± 10% 100VDC CER	28480	0160-4832
A57C11	0160-4832	4		CAPACITOR-FXD .01UF ± 10% 100VDC CER	28480	0160-4832
A57C12	0160-4832	4		CAPACITOR-FXD .01UF ± 10% 100VDC CER	28480	0160-4832
A57C13	0160-4832	4		CAPACITOR-FXD .01UF ± 10% 100VDC CER	28480	0160-4832
A57C14	0160-4832	4		CAPACITOR-FXD .01UF ± 10% 100VDC CER	28480	0160-4832
A57C15	0160-4832	4		CAPACITOR-FXD .01UF ± 10% 100VDC CER	28480	0160-4832
A57C16	0160-4832	4		CAPACITOR-FXD .01UF ± 10% 100VDC CER	28480	0160-4832
A57C17	0160-4823	3	1	CAPACITOR-FXD 820PF ± 5% 100VDC CER	28480	0160-4823
A57C18	0160-4801	7	1	CAPACITOR-FXD 100PF ± 5% 100VDC CER	28480	0160-4801
A57C19	0160-4832	4		CAPACITOR-FXD .01UF ± 10% 100VDC CER	28480	0160-4832
A57C20	0160-4807	3	3	CAPACITOR-FXD 33PF ± 5% 100VDC CER 0 ± 30	28480	0160-4807
A57C21	0160-4819	7	2	CAPACITOR-FXD 2200PF ± 5% 100VDC CER	28480	0160-4819
A57C22	0160-4819	7		CAPACITOR-FXD 2200PF ± 5% 100VDC CER	28480	0160-4819
A57C23	0160-4807	3		CAPACITOR-FXD 33PF ± 5% 100VDC CER 0 ± 30	28480	0160-4807
A57C24	0160-4807	3		CAPACITOR-FXD 33PF ± 5% 100VDC CER 0 ± 30	28480	0160-4807
A57C25	0160-4832	4		CAPACITOR-FXD .01UF ± 10% 100VDC CER	28480	0160-4832
A57C26	0160-4832	4		CAPACITOR-FXD .01UF ± 10% 100VDC CER	28480	0160-4832
A57C27	0160-4832	4		CAPACITOR-FXD .01UF ± 10% 100VDC CER	28480	0160-4832
A57C28	0160-4832	4		CAPACITOR-FXD .01UF ± 10% 100VDC CER	28480	0160-4832
A57CR1	1901-0535	9	4	DIODE-SM SIG SCHOTTKY	28480	1901-0535
A57CR2	1901-0535	9		DIODE-SM SIG SCHOTTKY	28480	1901-0535
A57CR3	1901-0535	9		DIODE-SM SIG SCHOTTKY	28480	1901-0535
A57CR4	1901-0535	9		DIODE-SM SIG SCHOTTKY	28480	1901-0535
A57CR5	1901-0033	2	6	DIODE-GEN PRP 180V 200MA DO-7	28480	1901-0033
A57CR6	1901-0033	2		DIODE-GEN PRP 180V 200MA DO-7	28480	1901-0033
A57CR7	1901-0033	2		DIODE-GEN PRP 180V 200MA DO-7	28480	1901-0033
A57CR8	1901-0033	2		DIODE-GEN PRP 180V 200MA DO-7	28480	1901-0033
A57CR9	1901-0033	2		DIODE-GEN PRP 180V 200MA DO-7	28480	1901-0033
A57CR10	1901-0033	2		DIODE-GEN PRP 180V 200MA DO-7	28480	1901-0033
A57L1	9100-3562	8	2	INDUCTOR RF-CH-MLD 4.7UH 5% .166DX.385LG	28480	9100-3562
A57L2	9100-3562	8		INDUCTOR RF-CH-MLD 4.7UH 5% .166DX.385LG	28480	9100-3562
A57L3	9100-1788	6	1	CHOKE-WIDE BAND ZMAX=680 OHM@ 180 MHZ	02114	VK200 20/48
A57MP1, 2	1480-0073	6	2	PIN-ROLL .062-IN-DIA .25-IN-LG BE-CU	28480	1480-0073
A57MP3	4040-0753	0	1	EXTR-PC BD GRN POLYC .062-BD-THKNS	28480	4040-0753
A57MP4	4040-0755	2	1	EXTR-PC BD VIO POLYC .062-BD-THKNS	28480	4040-0755
A57P1	1251-7469	3	1	CONN - POST TYPE	28480	1251-7469
A57Q1	1854-0404	0	1	TRANSISTOR NPN SI TO-18 PD=360MW	28480	1854-0404
A57Q2	1854-0477	7	1	TRANSISTOR NPN 2N2222A SI TO-18 PD=500MW	04713	2N2222A
A57Q3	1854-0361	8	1	TRANSISTOR NPN 2N4239 SI TO-5 PD=6W	04713	2N4239
A57R1	0757-0280	3	8	RESISTOR 1K 1% .125W F TC=0 ± 100	24546	C4-1/8-T0-1001-F
A57R2	0757-0280	3		RESISTOR 1K 1% .125W F TC=0 ± 100	24546	C4-1/8-T0-1001-F
A57R3	0757-0280	3		RESISTOR 1K 1% .125W F TC=0 ± 100	24546	C4-1/8-T0-1001-F
A57R4	0757-0442	9	4	RESISTOR 10K 1% .125W F TC=0 ± 100	24546	C4-1/8-T0-1002-F
A57R5	0698-3441	8	1	RESISTOR 215 1% .125W F TC=0 ± 100	24546	C4-1/8-T0-215R-F
A57R6	0757-0438	3	2	RESISTOR 5.11K 1% .125W F TC=0 ± 100	24546	C4-1/8-T0-5111-F
A57R7	0757-0402	1	1	RESISTOR 110 1% .125W F TC=0 ± 100 (RECOMMENDED REPLACEMENT)	24546	C4-1/8-T0-110R-F
A57R8				NOT ASSIGNED		
A57R9	0757-0403	2	1	RESISTOR 121 1% .125W F TC=0 ± 100	24546	C4-1/8-T0-121R-F
A57R10	0690-1021	0	2	RESISTOR 1K 10% 1W CC TC=0 ± 647	01121	GB1021
A57R11	0690-1021	0		RESISTOR 1K 10% 1W CC TC=0 ± 647	01121	GB1021
A57R12	0757-0401	0	2	RESISTOR 100 1% .125W F TC=0 ± 100	24546	C4-1/8-T0-101-F
A57R13	0757-0401	0		RESISTOR 100 1% .125W F TC=0 ± 100	24546	C4-1/8-T0-101-F
A57R14-16				NOT ASSIGNED		
A57R17	0698-0083	8	2	RESISTOR 1.96K 1% .125W F TC=0 ± 100	24546	C4-1/8-T0-1961-F
A57R18	0757-0394	0	1	RESISTOR 51.1 1% .125W F TC=0 ± 100	24546	C4-1/8-T0-51R1-F
A57R19	0757-0288	1	3	RESISTOR 9.09K 1% .125W F TC=0 ± 100	19701	MF4C1/8-T0-9091-F
A57R20	0757-0443	0	3	RESISTOR 11K 1% .125W F TC=0 ± 100	24546	C4-1/8-T0-1102-F
A57R21	0757-0288	1		RESISTOR 9.09K 1% .125W F TC=0 ± 100	19701	MF4C1/8-T0-9091-F
A57R22	0757-0288	1		RESISTOR 9.09K 1% .125W F TC=0 ± 100	19701	MF4C1/8-T0-9091-F

A57 Marker/Bandcross Component-Level Troubleshooting

Table A57-2. A57 Marker/Bandcross Replaceable Parts

Reference Designation	HP Part Number	C D	Qty	Description	Mfr Code	Mfr Part Number
A57R23	0757-0443	0		RESISTOR 11K 1% .125W F TC=0±100	24546	C4-1/8-T0-1102-F
A57R24	0757-0442	9		RESISTOR 10K 1% .125W F TC=0±100	24546	C4-1/8-T0-1002-F
A57R25	0757-0442	9		RESISTOR 10K 1% .125W F TC=0±100	24546	C4-1/8-T0-1002-F
A57R26	0757-0465	6	2	RESISTOR 100K 1% .125W F TC=0±100	24546	C4-1/8-T0-1003-F
A57R27	0757-0421	4	1	RESISTOR 825 1% .125W F TC=0±100	24546	C4-1/8-T0-825R-F
A57R28	0757-0465	6		RESISTOR 100K 1% .125W F TC=0±100	24546	C4-1/8-T0-1003-F
A57R29	0757-0438	3		RESISTOR 5.11K 1% .125W F TC=0±100	24546	C4-1/8-T0-5111-F
A57R30	0757-0443	0		RESISTOR 11K 1% .125W F TC=0±100	24546	C4-1/8-T0-1102-F
A57R31	0698-0083	8		RESISTOR 1.96K 1% .125W F TC=0±100	24546	C4-1/8-T0-1961-F
A57R32	2100-3757	6	1	RESISTOR-TRMR 100 10% C SIDE-ADJ 17-TRN	28480	2100-3757
A57R33	2100-3757	6	1	RESISTOR-TRMR 100 10% C SIDE-ADJ 17-TRN (RECOMMENDED REPLACEMENT)	28480	2100-3757
A57R34	0757-0280	3		RESISTOR 1K 1% .125W F TC=0±100	24546	C4-1/8-T0-1001-F
A57R35	0757-0280	3		RESISTOR 1K 1% .125W F TC=0±100	24546	C4-1/8-T0-1001-F
A57R36	0757-0280	3		RESISTOR 1K 1% .125W F TC=0±100	24546	C4-1/8-T0-1001-F
A57R37	0757-0280	3		RESISTOR 1K 1% .125W F TC=0±100	24546	C4-1/8-T0-1001-F
A57R38	0757-0280	3		RESISTOR 1K 1% .125W F TC=0±100	24546	C4-1/8-T0-1001-F
A57R39	0757-0346	2	2	RESISTOR 10 1% .125W F TC=0±100	24546	C4-1/8-T0-10R0-F
A57R40	0757-0346	2		RESISTOR 10 1% .125W F TC=0±100	24546	C4-1/8-T0-10R0-F
A57R41	0757-0442	9		RESISTOR 10K 1% .125W F TC=0±100	24546	C4-1/8-T0-1002-F
A57TP1	0360-2050	8	5	TEST POINT	28480	0360-2050
A57TP2	0360-2050	8		TEST POINT	28480	0360-2050
A57TP3	0360-2050	8		TEST POINT	28480	0360-2050
A57TP4	0360-2050	8		TEST POINT	28480	0360-2050
A57TP5	0360-2050	8		TEST POINT	28480	0360-2050
A57U1	1820-1194	6	2	IC CNTR TTL LS BIN UP/DOWN SYNCHRO	01295	SN74LS193N
A57U2	1818-0135	8	2	IC NMOS 1024 (1K) STAT RAM 360-NS 3-S	04713	MCM68A10L
A57U3	1820-1984	2	2	IC CONV 10-B-D/A 16-DIP-C PKG	24355	AD561KD
A57U4	1820-1984	2		IC CONV 10-B-D/A 16-DIP-C PKG	24355	AD561KD
A57U5	1820-1437	0	1	IC MV TTL LS MONOSTBL DUAL	01295	SN74LS221N
A57U6	1826-0098	9	1	IC COMPARATOR PRCN TO-99 PKG	27014	LM211H
A57U7	1826-0471	2	3	IC OP AMP LOW-DRIFT TO-99 PKG	28480	1826-0471
A57U8	1820-2075	4	2	IC MISC TTL LS	01295	SN74LS245N
A57U9	1820-1196	8	3	IC FF TTL LS D-TYPE POS-EDGE-TRIG COM	01295	SN74LS174N
A57U10	1820-1194	6		IC CNTR TTL LS BIN UP/DOWN SYNCHRO	01295	SN74LS193N
A57U11	1820-1112	8	2	IC FF TTL LS D-TYPE POS-EDGE-TRIG	01295	SN74LS74AN
A57U12	1820-1425	6	1	IC SCHMITT-TRIG TTL LS NAND QUAD 2-INP	01295	SN74LS132N
A57U13	1820-1272	1	1	IC BFR TTL LS NOR QUAD 2-INP	01295	SN74LS33N
A57U14	1826-0081	0	2	IC OP AMP WB TO-99 PKG	27014	LM318H
A57U15	1818-0135	8		IC NMOS 1024 (1K) STAT RAM 360-NS 3-S	04713	MCM68A10L
A57U16	1820-2075	4		IC MISC TTL LS	01295	SN74LS245N
A57U17	1820-1196	8		IC FF TTL LS D-TYPE POS-EDGE-TRIG COM	01295	SN74LS174N
A57U18	1820-1196	8		IC FF TTL LS D-TYPE POS-EDGE-TRIG COM	01295	SN74LS174N
A57U19	1820-1298	1	1	IC MUXR/DATA-SEL TTL LS 8-TO-1-LINE	01295	SN74LS251N
A57U20	1820-1144	6	2	IC GATE TTL LS NOR QUAD 2-INP	01295	SN74LS02N
A57U21	1820-1144	6		IC GATE TTL LS NOR QUAD 2-INP	01295	SN74LS02N
A57U22	1826-0081	0		IC OP AMP WB TO-99 PKG	27014	LM318H
A57U23	1820-1730	6	1	IC FF TTL LS D-TYPE POS-EDGE-TRIG COM	01295	SN74LS273N
A57U24	1820-1491	6	1	IC BFR TTL LS NON-INV HEX 1-INP	01295	SN74LS367AN
A57U25	1820-1216	3	2	IC DCDR TTL LS 3-TO-8-LINE 3-INP	01295	SN74LS138N
A57U26	1820-1112	8		IC FF TTL LS D-TYPE POS-EDGE-TRIG	01295	SN74LS74AN
A57U27	1826-0471	2		IC OP AMP LOW-DRIFT TO-99 PKG	28480	1826-0471
A57U28	1820-1216	3		IC DCDR TTL LS 3-TO-8-LINE 3-INP	01295	SN74LS138N
A57U29	1820-1201	6	1	IC GATE TTL LS AND QUAD 2-INP	01295	SN74LS08N
A57U30	1826-0471	2		IC OP AMP LOW-DRIFT TO-99 PKG	28480	1826-0471
A57U31	1810-0583	4	1	NETWORK-RES 16-DIP10.0K OHM X 8	28480	1810-0583
A57VR1	1902-3104	6	3	DIODE-ZNR 5.62V 5% DO-35 PD=-.4W	28480	1902-3104
A57VR2	1902-3104	6		DIODE-ZNR 5.62V 5% DO-35 PD=-.4W	28480	1902-3104
A57VR3	1902-3104	6		DIODE-ZNR 5.62V 5% DO-35 PD=-.4W	28480	1902-3104
A57VR4	1902-0579	3	2	DIODE-ZNR 5.1V 5% PD=1W IR=10UA	28480	1902-0579
A57VR5	1902-3357	1	1	DIODE-ZNR 56.2V 5% DO-7 PD=-.4W TC=-+.081%	28480	1902-3357
A57VR6	1902-0579	3		DIODE-ZNR 5.1V 5% PD=1W IR=10UA	28480	1902-0579

A59 Digital Interface Circuit Description

ASSEMBLY PURPOSE

The digital interface links the microprocessor to the sweep generator, the reference M/N oscillator, and the 20-30 synthesizer. The microprocessor read/write strobes enable buffers that either send data to the microprocessor, or clock registers that store data sent from the microprocessor. Several strobes also operate registers on other assemblies.

The digital interface assembly connects to the 16-bit data bus (DB0 to DB15). Using the LSTP (low stop) signal, this assembly can stop all microprocessor operations when all current tasks are completed. When the microprocessor stops, the RUN LED on the processor assembly turns off. LSTP stops the microprocessor when it is not needed, or when it is necessary to eliminate all potential sources of digital noise (e.g. during forward sweeps).

When the LSTP signal releases the microprocessor to perform a task, the microprocessor defers processing until it determines that the LSRQ (low service request) signal is low. LSRQ can be sent low by the digital interface, by the front panel processor, or by LBX (low bandcross). Once LSRQ is sensed low, it can go high again; the microprocessor finishes all pending tasks before checking this signal again.

Using the change detectors and the processor service request block, the microprocessor responds to the following:

- Changes in the UNLOCK or OVEN indicators
- Changes in OVERMOD or UNLEVELED conditions
- Changes in the EXTERNAL REFERENCE switch position
- Sweep events as indicated by the marker/bandcross assembly

The microprocessor also distinguishes between power on and instrument preset.

MICROPROCESSOR READ/WRITE STROBE (BLOCK A)

3-to-8 Decoders

Three decoders decode address lines ADR0 through ADR4 and SIOB. The outputs of these 3-to-8 decoders are used by circuits both on and off the A59 assembly either to clock latches connected to the I/O bus or to enable buffers connected to the bus (for output operations).

I/O Strobe B (SIOB)

SIOB is a 500 ns pulse that enables the three 3-to-8 decoders. While they are enabled, the logic signals on ADR0 through ADR4 select specific I/O addresses. For example, I/O address 0,R0: (channel 0, subchannel 0) causes a 500 ns strobe at pin 15 of the first decoder (LCK2).

PHASE LOCK INDICATORS AND CONTROL (BLOCK B)

Phase Lock Indicators

You can monitor the six phase lock loops in the instrument and determine if they are locked by writing a mask to the input buffer that selects individual lock indicator signals and allows the processor to test them via the Processor Service Request circuits (block H).

During instrument operation, the processor sends data to the input buffer that sets up the output flip-flops to monitor the phase lock indicators, which indicate either a locked or unlocked condition for a particular instrument function.

Lock and Roll

U22A and U22B are RS flip-flops whose inverted signals set flip-flops U22C and U22D. The outputs of U22C and U22D control the LOCK/ROLL signals for the 20-30 loop and the YO loop. Once U22C and U22D are set, the corresponding phase-lock loop tries to lock. This condition persists until the set signals are removed and the high sweep signal (HSP) goes high, indicating the start of sweep. This causes the appropriate oscillator to switch from LOCK to ROLL mode.

When the instrument sweeps, either the YO or the 20-30 oscillator is allowed to sweep by having its LOCK/ROLL control line (HLEY or HLEZ) set to ROLL. The 20-30 is swept when the YO Delta F is < 5 MHz.

NOTE: The YO DELTA F is the overall sweep width divided by the harmonic number (1 through 4).

The remaining outputs of the input buffer are ANDed with the corresponding oscillator LOCKED signals and ORed together by the output flip-flops to generate the UNLOCKED signal.

CHANGE DETECTOR (BLOCK C)

The instrument microprocessor responds to several conditions when they change state. Because the microprocessor stops running when it completes its tasks, the change detector circuit detects changes in instrument conditions and starts the microprocessor again so that it can interrogate the service request buffers and respond to the changes.

Types of Change

Detected changes:

- The oven either becomes cold, or comes up to temperature (HOVC)
- A change occurs in the enabled phase LOCK indicators (UNLOCKED)
- The rear panel frequency reference switch is set to EXT (HXREF)
- The LCHNG (low change) line is driven low due to a:
 1. change in the OVERMODULATION indicator,
 2. change in UNLEVELED indicator, or
 3. service request from the ADC.

Changes in the Oven (HOVC)

When the control signal from the oven (HOVC) falls below 3.5V, the output of the comparator goes HIGH. This signal is buffered by U7A, which drives U6B. In response to the positive change at pin 6, U6B immediately produces a low at pin 4 (LCHNG). Approximately 100 μ s later, when C2 is charged, pin 5 of U6B goes high, and the resulting negative going pulse from U6B causes flip-flop U4C to set. The output of U4C goes to block H, causing an instrument processor service request.

When the oven control signal changes in the opposite direction (i.e. rises above 3.5V), comparator changes states again, causing U6B to create a low-going pulse approximately 100 μ s wide.

The Low Change Line (LCHNG)

The LCHNG line, on the A62 motherboard, allows other circuits in the instrument to request service from the microprocessor.

Changes in the UNLOCKED and external reference signals also cause low-going pulses on the LCHNG line due to the wire-OR configuration. As with the HOVC control signal processing, an exclusive OR gate generates the low pulses on LCHNG.

M/N CONTROL (BLOCK E)

When the microprocessor writes to I/O address 3,R3;, it uses two registers to latch the control signals necessary to program the M/N oscillator.

MISCELLANEOUS INPUTS (BLOCK F)

A buffer allows the microprocessor to determine if an option is set. The input of I/O bit 4 (DB4) is tied low, and can be used by the microprocessor to determine that the digital interface is present.

MISCELLANEOUS CONTROL (BLOCK G)

When the microprocessor writes to I/O address 1,R3;, it uses a register to latch eight bits of information that are sent to the motherboard to control various functions.

Control Signals

The control signals are:

- **HSTD** (high standard). Turns on the +20V to the frequency standard (see A52). If the microprocessor sees that HXREF is low (as set by the rear panel switch), it sets HSTD high.
- **HFILYO** (high filtered YO). A high places a large filter capacitor across the YO coil. This happens in the CW or MANUAL mode.

- **LRSP** (low reset sweep). A low at the end of every sweep causes the sweep generator to reset the sweep. The reset signal is removed before the sweep starts.
- **LYSP** (low YO sweep). A TTL signal that goes to the A55 YO driver assembly. LYSP is low for YO sweep widths greater than 5 MHz, and switches out a filtering capacitor on the A55 assembly to remove any swept frequency delay.
- **HCEN** (high compensation enable). A TTL signal that goes to the A55 YO driver assembly. When high, HCEN allows the ramp voltage VCOMP to be added to PRETUNE on the driver assembly to compensate for the YO swept frequency delay.

PROCESSOR SERVICE REQUESTS (BLOCK H)

Buffer/Register

The microprocessor uses a buffer/register to determine which tasks need to be performed. All conditions needing the processor's attention (except for the front panel, which generates its own service request) are communicated through this register.

Service Request Line (LSRQ)

All possible reasons for service are ORed, and the result is sent to the microprocessor on the LSRQ line, indicating that service is requested. LSRQ can be driven low by instrument preset, by bandcross signals, or by the front panel (indicating a key has been pushed or the front panel knob has been turned).

Stop Line (LSTP)

The LSTP line stops the microprocessor after all pending tasks are completed.

Conditions that Can be Monitored

When the microprocessor reads I/O address 4,R3:, the following conditions can be monitored:

- **BANDCROSS**. This line is driven by the LBX from the A57 marker/bandcross assembly. After being inverted on the A59 assembly, BANDCROSS goes high when a sweep event (except for a marker) occurs. The sweep generator can also drive the LBX line if the sweep exceeds 12V.
- **UNLOCKED**. An oscillator is unlocked.
- **EXT REF**. External reference is selected by the rear panel frequency standard INT/EXT switch.
- **OVEN**. The oven is up to temperature.
- **POWER FAIL**. This indicates that a power on has just occurred. This is used by the microprocessor to distinguish between power on (restore the last state) and instrument preset.
- **CHANGE FF**. One of the change detector inputs has changed.

A59 Digital Interface Component-Level Troubleshooting

CHECKING THE MICROPROCESSOR I/O ADDRESS STROBES (BLOCK A)

U12, U19, and U26 are connected to the I/O address bus and generate 24 I/O strobcs that are either used on this assembly or sent to other assemblies. These strobcs can be checked using the front panel to write directly to the I/O addresses while monitoring the 3-to-8 decoders outputs.

Procedure

1. Press **[INSTR PRESET] [MANUAL]**.
2. Connect a logic probe to the output you wish to check.
3. Enter the desired I/O address (shown on the schematic above the outputs of U12, U19, and U26).

For example, enter address 3,R3: as follows:

- a. Set the I/O channel
Press **[SHIFT] [GHz] [3] [Hz]**
- b. Set the I/O subchannel
Press **[SHIFT] [MHz] [3] [Hz]**
- c. Activate the selected I/O address
Press **[SHIFT] [kHz]**
- d. Make entries using the step keys, the front panel knob, or the data pad. Each entry generates the M/N oscillator control strobe, an active low signal approximately 500 ns wide that can be monitored with the logic probe, or seen on a storage scope.

For more direct I/O addressing information, refer to COMPONENT-LEVEL SERVICE INTRODUCTION in volume 1 of this manual set.

CHECKING MICROPROCESSOR OUTPUT DEVICES (BLOCKS B, E, and G)

The following are microprocessor output devices:

- U24 (block B)
- U10 and U17 (block E)
- U23 (block G)

Microprocessor output devices can be checked using direct I/O addressing, as described for block A. Monitor the outputs as you enter the numbers that effect the signals you are interested in. For example, if the signal of interest is taken from DB2, enter the number 0 and observe the register output; it should go low. Enter the number 4; DB2 goes high.

CHECKING MICROPROCESSOR INPUT DEVICES (BLOCKS F and H)

You can check input devices (U7 and U18) the same way you check output devices:

1. Use the front panel to set up the I/O channel and subchannel.
2. After you press **[SHIFT] [Hz]**, each time you press **[Hz]** the instrument reads from the addressed I/O device and displays the results in the entry display in both decimal and octal formats.
3. To check each input device, short each input to +5V or ground (through a current limiting resistor), as applicable. Note that U18 is an inverting buffer; a low at its input should produce a high at the output.

CHANGE DETECTORS (BLOCK C)

To Check INT/EXT:

1. Connect a logic probe or storage scope to test point 8 (CHGFF).
2. Check that an active low pulse is generated each time you switch the rear panel frequency standard INT/EXT switch (in either direction).
3. Check that the front panel EXT REF LED is on when the frequency standard switch is in the EXT position, and is off when the switch is in the INT position.

To Check the UNLOCKED Input:

1. Select CW.
2. Disconnect one of the snap-on cables in the phase locked loop.
3. Check for a pulse at test point 8 and that the front panel UNLOCKED LED lights.
4. Reconnect the cable; check that the UNLOCKED LED goes out.

To Check the Oven Line (HOVC):

1. Unplug the instrument.
2. After 5 minutes, plug in the instrument and turn it on.
3. Check that the OVEN LED lights and, after a few minutes, goes off.

PROCESSOR SERVICE REQUEST (BLOCK H)

To Check U18:

1. Check U18 as you would any other input device (see block F and H troubleshooting)

2. Use direct I/O addressing to check that U18 bit 14 is high:

Press [INSTR PRESET]
[SHIFT] [GHz]
[4] [Hz]
[SHIFT] [MHz]
[3] [Hz]
[SHIFT] [Hz]

Two numbers appear in the ENTRY display. The number on the right is an octal (base 8) number. For bit 14 to be high, the second digit from the left in this number must be a four, a six, or a seven.

To Check the Rest of Block H:

1. Press [INSTR PRESET] [CW].
2. Check that the RUN LED on the processor assembly is off. If the LED is lit, either the LSRQ (low service request) line is pulled low, or U4D has not been set by the microprocessor.

LSTP (low stop sweep) must be low for the processor run LED to go out.

NOTE: If the instrument is UNLOCKED because of a hardware problem, the processor runs continuously; in this case, LSTP remains high.
3. Ground the LBX test point on the marker/bandcross assembly.
4. Check that test point 6 goes high, LSRQ goes low, and LSTP goes high.

A59 Digital Interface Component-Level Troubleshooting

Table A59-1. A59 Digital Interface P1 Pin I/O (1 of 3)

Pin	Mnemonic	Levels	Source	Destination
1 56	GND PLANE GND PLANE	0V 0V	INSTRUMENT GROUND INSTRUMENT GROUND	*J *J
2 57				
3 58				
4 59				
5 60				
6 61				
7 62				
8 63				
9 64				
10 65	HOVC LSTP	+ 3 VOLTS - OVEN WARM TTL (LOW TRUE)	A62J3-3 I	C XA6101-85 *
11 66	LYSP HSTD	TTL (LOW TRUE) TTL (HIGH TRUE)	G G	XA55P1-7 XA52P1-21
12 67	HCEN	TTL (HIGH TRUE)	G	XA55P1-14
13 68	HSP WPDAC	TTL (HIGH TRUE) TTL (LOW TRUE)	XA57P1-13 A	*B XA54P1-36
14 69	LIPS LBX	TTL (LOW TRUE) TTL (LOW TRUE)	XA52P1-36/A62J7-19 *	*I I
15 70	SIOA	TTL (LOW TRUE)	XA60P1-15	*NOT USED
16 71	SIOB	TTL (LOW TRUE)	XA60P1-16	*A
17 72	ADRO HFILYO	TTL TTL	XA60P1-17 G	*A *XA58P1-47, 72
18 73	ADR2 ADR1	TTL TTL	XA60P1-18 XA60P1-73	*A *A
19 74	ADR4 ADR3	TTL TTL	XA60P1-19 XA60P1-74	*A *A

A single letter in the source or destination column refers to a function block on this assembly schematic.

An asterisk (*) denotes multiple sources or destinations; refer to the A62 motherboard wiring list for a complete representation of signal sources and destinations.

A59 Digital Interface Component-Level Troubleshooting

Table A59-1. A59 Digital Interface P1 Pin I/O (2 of 3)

Pin	Mnemonic	Levels	Source	Destination
20 75	DB0 GND PLANE	TTL 0V	*D XA60P1-20 INSTRUMENT GROUND	*D E G *J
21 76	DB2 DB1	TTL TTL	*D XA60P1-21 *D XA60P1-76	*D E G *D E G
22 77	DB4 DB3	TTL TTL	*D F XA60P1-22 *D XA60P1-77	*D E G *D E G
23 78	DB6 DB5	TTL TTL	*D F XA60P1-23 *D F XA60P1-78	*D G *D E G
24 79	DB8 DB7	TTL TTL	*XA60P1-24 *D F XA60P1-79	*B D I *D G
25 80	DB10 DB9	TTL TTL	*XA60P1-25 *XA60P1-80	*B E I *B I
26 81	DB12 DB11	TTL TTL	*XA60P1-26 *XA60P1-81	*B E I *B E I
27 82	DB14 DB13	TTL TTL	*XA60P1-27 *XA60P1-82	*B E I *B E I
28 83	WSPTM DB15	TTL (LOW TRUE) TTL	A *XA60P1-83	XA58P1-28 *B E I
29 84	WRDAC WSPAT	TTL (LOW TRUE) TTL (LOW TRUE)	A A	XA58P1-29 XA58P1-84
30 85	WCDAC LRSP	TTL (LOW TRUE) TTL (LOW TRUE)	A G	XA54P1-28 XA58P1-85
31 86	M5 LMNE	TTL (HIGH TRUE) TTL (LOW TRUE)	E E	XA34P1-1 XA34P1-2
32 87	M3 M4	TTL (HIGH TRUE) TTL (HIGH TRUE)	E E	XAE4P1-3 XA34P1-4
33 88	M1 M2	TTL (HIGH TRUE) TTL (HIGH TRUE)	E E	XA34P1-5 XA34P1-6
34 89	5 MHZ CLK LSRQ	TTL TTL (LOW TRUE)	XA60P1-34 *I	D *
35 90	+20V +20V	+20V +20V	XA52P1-16, 40 XA52P1-16, 40	*NOT USED *NOT USED
36 91	+5.2V +12V	+5.2V +12V	XA52P1-17, 18, 41, 42 XA52P1-9, 33	*J *NOT USED
37 92	+5.2V +5.2V	+5.2V +5.2V	XA52P1-17, 18, 41, 42 XA52P1-17, 18, 41, 42	*J *J

A single letter in the source or destination column refers to a function block on this assembly schematic.

An asterisk (*) denotes multiple sources or destinations; refer to the A62 motherboard wiring list for a complete representation of signal sources and destinations.

A59 Digital Interface Component-Level Troubleshooting

Table A59-1. A59 Digital Interface P1 Pin I/O (3 of 3)

Pin	Mnemonic	Levels	Source	Destination
38 93	-15V -5.2V	-15V -5.2V	XA56P1-15, 30 XA53P1-18, 36	*NOT USED *NOT USED
39 94	-10V -10V	-10V -10V	XA53P1-12, 13, 31, 32 XA53P1-12, 13, 31, 32	*NOT USED *NOT USED
40 95	GND PLANE HPUP	0V TTL (HIGH TRUE)	INSTRUMENT GROUND XA52P1-46	*J *D I
41 96	GND PLANE GND PLANE	0V 0V	INSTRUMENT GROUND INSTRUMENT GROUND	*J *J
42 97	GND PLANE GND PLANE	0V 0V	INSTRUMENT GROUND INSTRUMENT GROUND	*J *J
43 98	GND PLANE HXREF	0V TTL (HIGH TRUE)	INSTRUMENT GROUND A62J31-17	*J *C
44 99	GND PLANE WYOKW	0V TTL (LOW TRUE)	INSTRUMENT GROUND A	*J XA54P1-6
45 100	LCHNG TYOKP	TTL (LOW TRUE) TTL (LOW TRUE)	* A	C *
46 101	N5 N6	TTL TTL	E E	XA34P1-11 XA34P1-10
47 102	N3 N4	TTL TTL	E E	XA34P1-13 XA34P1-12
48 103	N1 N2	TTL TTL	E E	XA34P1-15 XA34P1-14
49 104	HULR HULM	TTL (HIGH TRUE) TTL (HIGH TRUE)	XA34P2-14 XA34P1-8	B B
50 105	HULY HULH	TTL (HIGH TRUE) TTL (HIGH TRUE)	A62J2-16 A62J19-16	B *B
51 106	HLEY HUL1	TTL (HIGH TRUE) TTL (HIGH TRUE)	B XA37P1-26; XA39P1-1, 16	A62J2-3 B
52 107	LCK4 HUL2	TTL (LOW TRUE) TTL (HIGH TRUE)	A XA41P1-4	* B
53 108	HLE2 LCK3	TTL (HIGH TRUE) TTL (LOW TRUE)	B A	* XA43P1-19
54 109	LCK1 LCK2	TTL (LOW TRUE) TTL (LOW TRUE)	A A	XA42P1-19 XA42P1-1
55 110	GND PLANE GND PLANE	0V 0V	INSTRUMENT GROUND INSTRUMENT GROUND	*J *J

A single letter in the source or destination column refers to a function block on this assembly schematic.

An asterisk (*) denotes multiple sources or destinations; refer to the A62 motherboard wiring list for a complete representation of signal sources and destinations.

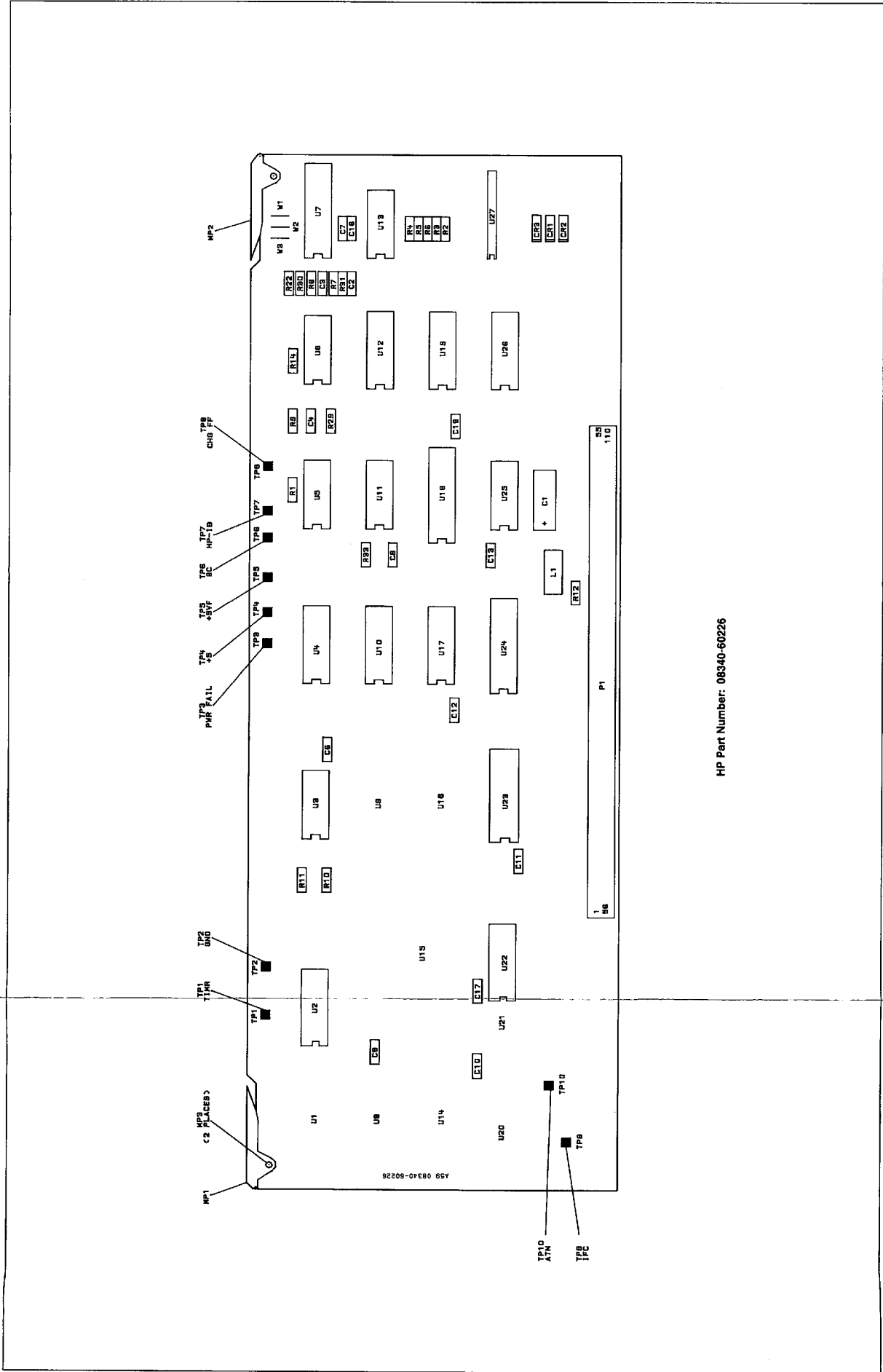

HP Part Number: 08340-60226

Figure A59-1. A59 Digital Interface, Component Location Diagram
A59-12 Controller

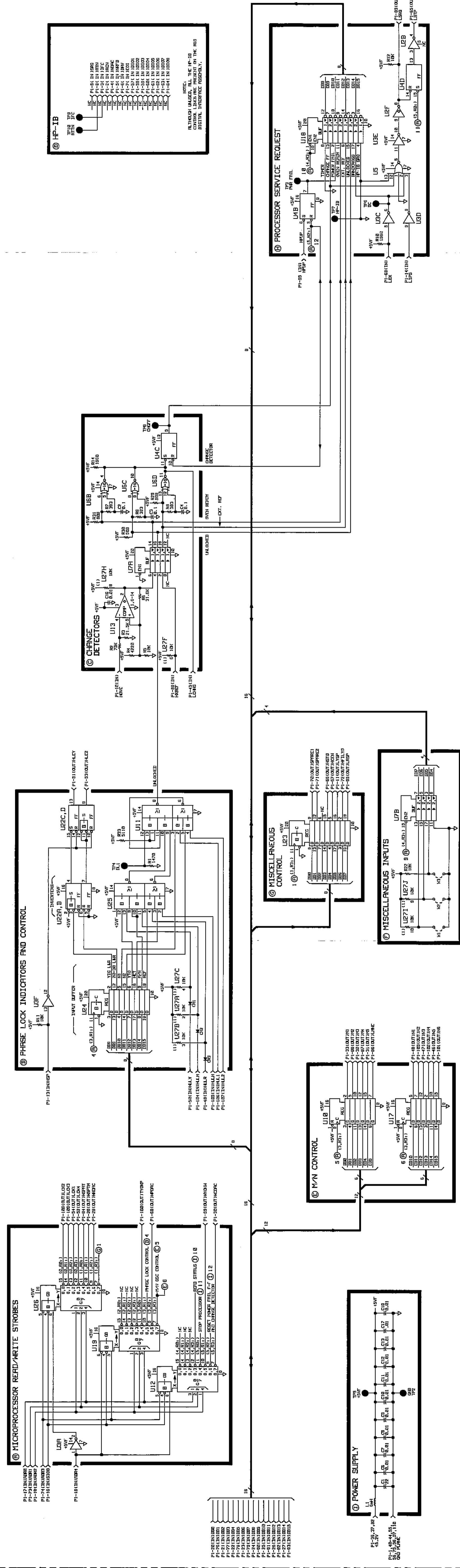

Figure A59-2. A59 Digital Interface, Schematic Diagram
Controller A59-13/A59-14

A59 Digital Interface Component-Level Troubleshooting

Table A59-2. A59 Digital Interface Replaceable Parts

Reference Designation	HP Part Number	C D	Qty	Description	Mfr Code	Mfr Part Number
A59	08340-60226	1	1	DIGITAL INTERFACE ASSEMBLY	28480	08340-60226
A59C1	0180-2228	6	1	CAPACITOR-FXD 22UF ± 10% 15VDC TA	56289	150D226X9015B2
A59C2	0160-4557	0	3	CAPACITOR-FXD .1UF ± 20% 50VDC CER	16299	CAC04X7R104M050A
A59C3	0160-4557	0		CAPACITOR-FXD .1UF ± 20% 50VDC CER	16299	CAC04X7R104M050A
A59C4	0160-4557	0		CAPACITOR-FXD .1UF ± 20% 50VDC CER	16299	CAC04X7R104M050A
A59C5				NOT ASSIGNED		
A59C6	0160-4832	4	11	CAPACITOR-FXD .01UF ± 10% 100VDC CER	28480	0160-4832
A59C7	0160-4832	4		CAPACITOR-FXD .01UF ± 10% 100VDC CER	28480	0160-4832
A59C8	0160-4832	4		CAPACITOR-FXD .01UF ± 10% 100VDC CER	28480	0160-4832
A59C9	0160-4832	4		CAPACITOR-FXD .01UF ± 10% 100VDC CER	28480	0160-4832
A59C10	0160-4832	4		CAPACITOR-FXD .01UF ± 10% 100VDC CER	28480	0160-4832
A59C11	0160-4832	4		CAPACITOR-FXD .01UF ± 10% 100VDC CER	28480	0160-4832
A59C12	0160-4832	4		CAPACITOR-FXD .01UF ± 10% 100VDC CER	28480	0160-4832
A59C13	0160-4832	4		CAPACITOR-FXD .01UF ± 10% 100VDC CER	28480	0160-4832
A59C14				NOT ASSIGNED		
A59C15				NOT ASSIGNED		
A59C16	0160-4832	4		CAPACITOR-FXD .01UF ± 10% 100VDC CER	28480	0160-4832
A59C17	0160-4832	4		CAPACITOR-FXD .01UF ± 10% 100VDC CER	28480	0160-4832
A59C18	0160-4832	4		CAPACITOR-FXD .01UF ± 10% 100VDC CER	28480	0160-4832
A59CR1	1901-0033	2	3	DIODE-GEN PRP 180V 200MA DO-7	28480	1901-0033
A59CR2	1901-0033	2		DIODE-GEN PRP 180V 200MA DO-7	28480	1901-0033
A59CR3	1901-0033	2		DIODE-GEN PRP 180V 200MA DO-7	28480	1901-0033
A59L1	9011-1788	6	1	CHOKE-WIDE BAND ZMAX=680Ω @ 180 MHZ	02114	VK200 20/48
A59MP1	4040-0756	3	1	EXTR-PC BD WHT POLY .062-BD-THKNS	28480	4040-0756
A59MP2,3	1480-0073	6	2	PIN-ROLL .062-IN-DIA .25-IN-LG BE-CU	28480	1480-0073
A59MP4	4040-0753	0	1	EXTR-PC BD GRN POLY .062-BD-THKNS	28480	4040-0753
A59P1	1251-7469	3	1	CONN-POST TYPE .100-PIN-SPCG 110-CONT	28480	1251-7469
A59R1	0757-1094	9	1	RESISTOR 1.47K 1% .125W F TC=0 ± 100	24546	C4-1/8-T0-1471-F
A59R2	0757-0462	3	1	RESISTOR 75K 1% .125W F TC=0 ± 100	24546	C3-1/8-T0-7502-F
A59R3	0757-0199	3	1	RESISTOR 21.5K 1% .125W F TC=0 ± 100	24546	C4-1/8-T0-2152-F
A59R4	0698-3154	0	1	RESISTOR 4.22K 1% .125W F TC=0 ± 100	24546	C4-1/8-T0-4221-F
A59R5	0757-0442	9	5	RESISTOR 10K 1% .125W F TC=0 ± 100	24546	C4-1/8-T0-1002-F
A59R6	0698-3160	8	1	RESISTOR 31.6K 1% .125W F TC=0 ± 100	24546	C4-1/8-T0-3162-F
A59R7	0698-3446	3	3	RESISTOR 383 1% .125W F TC=0 ± 100	03292	C4-1/8-T0-383R-F
A59R8	0698-3446	3		RESISTOR 383 1% .125W F TC=0 ± 100	03292	C4-1/8-T0-383R-F
A59R9	0698-3446	3		RESISTOR 383 1% .125W F TC=0 ± 100	03292	C4-1/8-T0-383R-F
A59R10	0698-0083	8	2	RESISTOR 1.96K 1% .125W F TC=0 ± 100	24546	C4-1/8-T0-1961-F
A59R11	0757-0442	9		RESISTOR 10K 1% .125W F TC=0 ± 100	24546	C4-1/8-T0-1002-F
A59R12	0757-0442	9		RESISTOR 10K 1% .125W F TC=0 ± 100	24546	C4-1/8-T0-1002-F
A59R13				NOT ASSIGNED		
A59R14	0698-0083	8		RESISTOR 1.96K 1% .125W F TC=0 ± 100	24546	C4-1/8-T0-1961-F
A59R15-21				NOT ASSIGNED		
A59R22	0757-0442	9		RESISTOR 10K 1% .125W F TC=0 ± 100	24546	C4-1/8-T0-1002-F
A59R23-24				NOT ASSIGNED		
A59R25	0757-0442	9		RESISTOR 10K 1% .125W F TC=0 ± 100	24546	C4-1/8-T0-1002-F
A59R26-28				NOT ASSIGNED		
A59R29	0757-0422	5	3	RESISTOR 909 1% .125W F TC=0 ± 100	03292	CT4-1/8-T0-909R-F
A59R30	0757-0422	5		RESISTOR 909 1% .125W F TC=0 ± 100	03292	CT4-1/8-T0-909R-F
A59R31	0757-0422	5		RESISTOR 909 1% .125W F TC=0 ± 100	03292	CT4-1/8-T0-909R-F
A59R32				NOT ASSIGNED		
A59R33	0757-0438	3	1	RESISTOR 5.11K 1% .125W F TC=0 ± 100	03292	CT4-1/8-T0-5111-F
A59TP1	0360-0535	0	10	TERMINAL TEST POINT, PCB	00000	ORDER BY DESCRIPTION
A59TP2	0360-0535	0		TERMINAL TEST POINT, PCB	00000	ORDER BY DESCRIPTION
A59TP3	0360-0535	0		TERMINAL TEST POINT, PCB	00000	ORDER BY DESCRIPTION
A59TP4	0360-0535	0		TERMINAL TEST POINT, PCB	00000	ORDER BY DESCRIPTION
A59TP5	0360-0535	0		TERMINAL TEST POINT, PCB	00000	ORDER BY DESCRIPTION
A59TP6	0360-0535	0		TERMINAL TEST POINT, PCB	00000	ORDER BY DESCRIPTION
A59TP7	0360-0535	0		TERMINAL TEST POINT, PCB	00000	ORDER BY DESCRIPTION
A59TP8	0360-0535	0		TERMINAL TEST POINT, PCB	00000	ORDER BY DESCRIPTION
A59TP9	0360-0535	0		TERMINAL TEST POINT, PCB	00000	ORDER BY DESCRIPTION
A59TP10	0360-0535	0		TERMINAL TEST POINT, PCB	00000	ORDER BY DESCRIPTION
A59U1				NOT ASSIGNED		
A59U2	1820-0577	7	2	IC INV TTL HEX 1-INP	01295	SN7416N
A59U3	1820-1416	5	1	IC SCHMITT-TRIG TTL LS INV HEX 1-INP	01295	SN74LS14N
A59U4	1820-1440	5	2	IC LCH TTL LS QUAD	01295	SN74LS279N
A59U5	1820-1905	7	1	IC GATE TTL LS NOR DUAL 5-INP	07263	74LS260PC

A59 Digital Interface Component-Level Troubleshooting

Table A59-2. A59 Digital Interface Replaceable Parts

Reference Designation	HP Part Number	C D	Qty	Description	Mfr Code	Mfr Part Number
A59U6	1820-1297	0	1	IC GATE TTL LS EXCL-NOT QUAD 2-INP	01295	SN74LS266N
A59U7	1820-2024	3	1	IC DRVR TTL LS LINE DRVR OCTL	01295	SN74LS244N
A59U8				NOT ASSIGNED		
A59U9	1820-1196	8	3	IC FF TTL LS D-TYPE POS-EDGE-TRIG COM	01295	SN74LS174
A59U10	1820-1196	8		IC FF TTL LS D-TYPE POS-EDGE-TRIG COM	01295	SN74LS174N
A59U11	1820-1210	7	2	IC GATE TTL LS AND-OR-INV DUAL 2-INP	01295	SN74LS51N
A59U12	1820-1216	3	3	IC DCDR TTL LS 3-TO-8-LINE 3-INP	01295	SN74LS138N
A59U13	1826-0138	8	1	IC COMPARATOR GP QUAD 14-DIP-P PKG	01295	LM339N
A59U14-16				NOT ASSIGNED		
A59U17	1820-1196	8		IC FF TTL LS D-TYPE POS-EDGE-TRIG COM	01295	SN74LS174N
A59U18	1820-1917	1	1	IC BFR TTL LS LINE DRVR OCTL	01295	SN74LS240N
A59U19	1820-1216	3		IC DCDR TTL LS 3-TO-8-LINE 3-INP	01295	SN74LS138N
A59U20				NOT ASSIGNED		
A59U21				NOT ASSIGNED		
A59U22	1820-1440	5		IC LCH TTL LS QUAD	01295	SN74LS279N
A59U23	1820-1858	9	2	IC FF TTL LS D-TYPE OCTL	01295	SN74LS377N
A59U24	1820-1858	9		IC FF TTL LS D-TYPE OCTL	01295	SN74LS377N
A59U25	1820-1210	7		IC GATE TTL LS AND-OR-INV DUAL 2-INP	01295	SN74LS51N
A59U26	1820-1216	3		IC DCDR TTL LS 3-TO-8-LINE 3-INP	01295	SN74LS138N
A59U27	1810-0280	8	1	NETWORK-RES 10-SIP 10.0KΩ X 9	01121	210A103
A59W1	1460-1489	8	3	WIREFORM BE CU AG	28480	1460-1489
A59W2	1460-1489	8		WIREFORM BE CU AG	28480	1460-1489
A59W3	1460-1489	8		WIREFORM BE CU AG	28480	1460-1489

A60 Processor Circuit Description

ASSEMBLY PURPOSE

The A60 processor assembly performs all instrument data processing. This assembly consist of:

- A microprocessor
- Memory
- An HP-IB interface
- The necessary circuitry for:
 - Clock generation
 - Address and memory decoding
 - Buffering
 - Interrupt handling

The microprocessor interfaces directly with memory, which consists of:

- 64K words of Ultra Violet Erasable Programmable Read Only Memory (UVEPROM)
The instrument software program (firmware) is stored in this section of memory, with the default calibration data.
- 2K words of Electrically Erasable Programmable Read Only Memory (EEPROM)
Protected calibration data is stored here.
- 8K words of Random Access Memory (RAM)
Working calibration data and SAVE/RECALL register values are stored here. Battery backup provides power to RAM when AC power is disconnected. If the backup power fails, working calibration data and SAVE/RECALL information is lost. When AC power is restored, the EEPROM calibration data is loaded in RAM, and the front panel displays CALIBRATION RESTORED.

NOTE: 1 word = 2 bytes; 1 byte = 8 bits.

The microprocessor is controlled by the firmware stored in memory. With this program, the microprocessor can transfer data (I/O addressing) and internally process data it has accessed. All data transfers go through the microprocessor.

The A60 processor assembly communicates with the rest of the instrument by means of the internal address and data busses. External communication is through the HP-IB connection on the rear panel. The HP-IB interface circuitry provides the link between the internal instrument bus and the external HP-IB interface.

MEMORY (BLOCKS A, B, and C)

UVEPROM (block A) has 64K words of programmed firmware that contains the complete instrument operating program.

EEPROM (block B) has 2K words of electrically alterable memory that contains protected calibration data (calibration constants).

RAM (block C) has 8K words of volatile memory that is used for working calibration data and SAVE/RECALL registers. Block G provides battery backup for RAM if line power is disconnected.

TIMER/SELF TEST INDICATOR/DSA (BLOCK D)

This block contains a counter-timer and a parallel interface adapter for:

- RUN/STOP indication for the instrument microprocessor.
- Test output signals for the test LEDs.
- Interrupts with timer countdown.
- Control points for testing and for DSA:
 - TP1 Non-destructive RAM testing
 - TP2 — 5 DSA controls
 - TP6 Status line control for RAM testing

I/O DECODING AND CONTROL (BLOCK E)

The I/O decoder consists of two PLA (programmable logic array) devices that form a state machine for I/O bus control. Address and control lines develop the output control signal state equations (AND/OR/INVERSION).

The I/O decoder outputs provide control for the I/O data bus buffers (block N), the I/O address bus buffer (block P), and the HP-IB interface (block M).

SELF TEST (BLOCK F)

The self test registers interface the instrument data and address busses to the I/O data and address busses. Both the address and data lines are checked as follows:

- **Address.** An I/O bus transfer is initiated with the I/O address latched onto the address register. Using control lines, the instrument microprocessor monitors the address under test.
- **Data.** I/O data is latched into the buffers and checked by the microprocessor.

POWER SUPPLIES (BLOCK G)

The main instrument power supplies provide the inputs to the A60 assembly. The +22 VDC supply is the standby supply when the instrument is plugged in, and provides RAM voltage during standby and normal operation.

When the instrument is unplugged, the battery (BT1) provides power to maintain calibration constant information in RAM.

The +1.2 VDC supply provides comparator reference voltage for the A60 assembly POWER UP/ STOP circuitry.

Supply power from capacitors C3 and C5 allow the microprocessor to complete operations and set registers and memory if main instrument power is disconnected or lost.

MEMORY DECODING (BLOCK H)

The memory decoder is a PLA (programmable logic array) that uses address and control lines to create the PLA equations for proper memory address locations.

Output control lines are derived from the AND/OR/INVERSION combinations of the input lines. The memory decoding controls the UVEPROM, EEPROM, RAM, and I/O addressing, according to the memory map in Figure A60-1.

CLOCK (BLOCK I)

The crystal output (approximately 14.75 MHz) is shaped by an RC series circuit for waveshaping and RFI elimination, and divided-by-two by a flip-flop to provide the main output clock signals (LCLK and CLK).

The 7.4 MHz clock signals are again divided-by-two for the HP-IB clock signal (approximately 3.6 MHz).

INTERRUPT ENCODER (BLOCK J)

An 8-to-3 encoder provides three level-interrupt signals to the microprocessor. The least significant input is connected to ground, which maintains the encoder outputs high when no interrupts are pending.

PROCESSOR MEMORY MAP

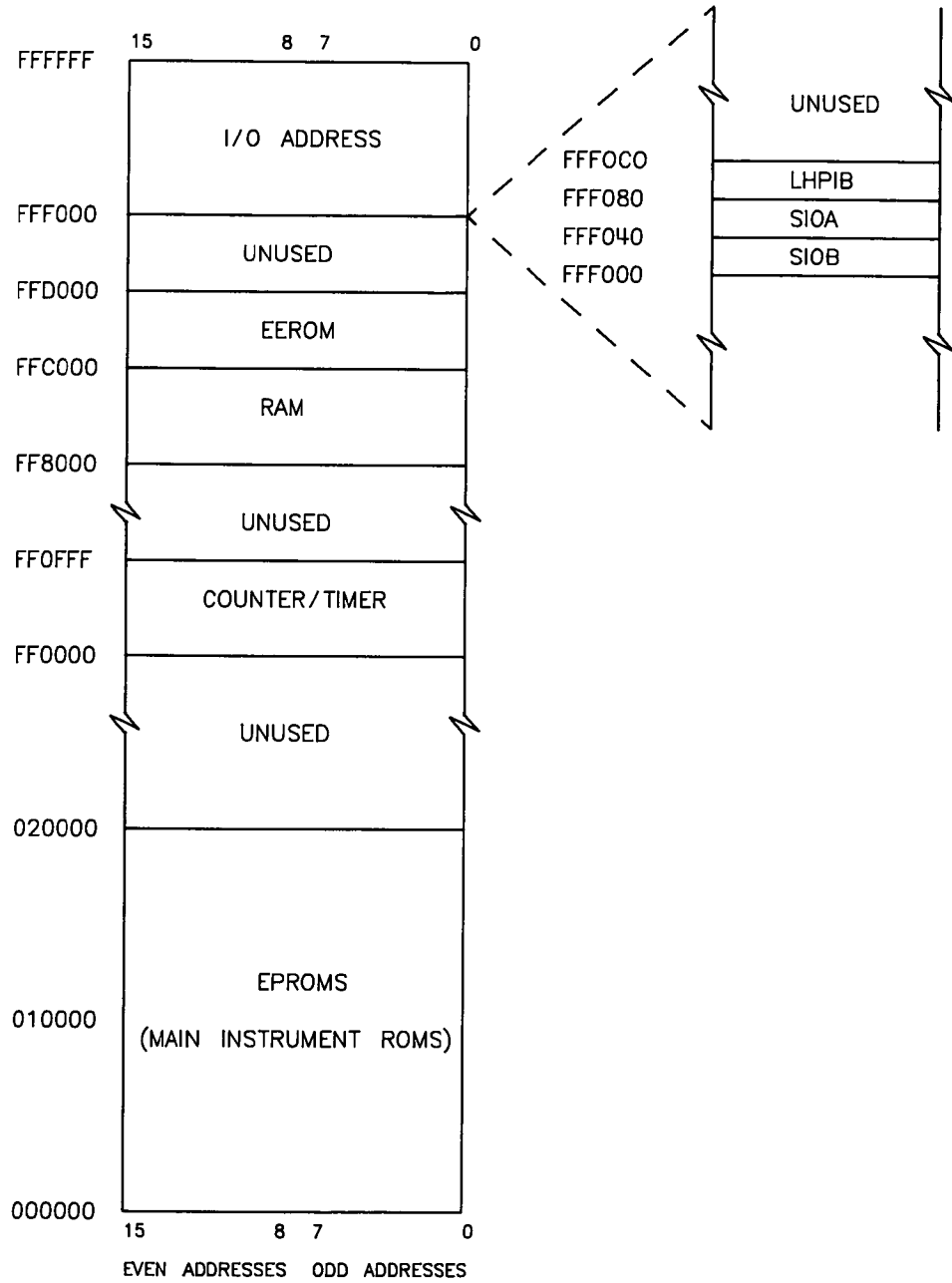

Figure A60-1. Microprocessor Memory Map

PROCESSOR (BLOCK K)

The microprocessor is a 16-bit Motorola 68000, with a 16-bit data bus and a 23-bit address bus. Instrument control is provided by the following lines:

- Interrupt control
- Bus control and arbitration
- Peripheral control
- Microprocessor status

The microprocessor data bus, pulled up to +5 VDC, is the main instrument bus for the transfer of data throughout the instrument.

The address bus uses only 17 of the available 23 lines. AD0 is internal to the microprocessor for byte (upper/lower) determination. The unused address lines are sign extended so as not to slow microprocessor operation. A18 is a control line for DSA troubleshooting.

The microprocessor status line outputs indicate the microprocessor state (user or supervisor), and the type of cycle. The lines are gated to the VPA input, and must be correct for the processor to function.

The microprocessor uses an automatic vectored interrupt system, with encoded interrupt requests from the interrupt encoder (block J). When an interrupt is active, the microprocessor jumps to the proper memory address for the service routine.

FREE RUN DSA (BLOCK L)

Free run DSA is a routine where the microprocessor completes a "no op" instruction and increments through its complete address sequence. This mode of operation is required for address bus troubleshooting.

HP-IB INTERFACE (BLOCK M)

The interface circuitry contains a VLSI HP-IB chip, and two bidirectional bus drivers to interface the main instrument to external devices and controllers.

The VLSI chip contains the necessary circuitry for all control signals and handshaking required for HP-IB control. The HP-IB clock signal is used for bus transfer timing, with the VLSI chip controlling the actual data transfer through the bidirectional latches.

HP-IB operations are interrupt driven, with the main instrument microprocessor servicing the request after it is received.

I/O DATA BUS BUFFERS (BLOCK N)

The I/O data bus buffers provide a bidirectional interface between the instrument data bus and the I/O data bus. Internal latches hold the data until it is needed by the microprocessor or by I/O devices.

When there is no activity on the I/O data bus, all lines are held low, to minimize noise.

Four control lines (shown in Table A60-1) control the I/O data bus buffer control logic.

Table A60-1. I/O Buffers Truth Table

Control Lines				Operation
DISDB	DB DAT CLK	SE LAB	DIR AB	
High	Low → High	X	X	Store data in A latches
Low	X	High	High	Store A data to B bus
Low	X	Low	Low	I/O bus read
Low	X	Low	High	I/O bus write

Figure A60-2 shows I/O bus write cycle and read cycle timing diagrams.

I/O BUS WRITE CYCLE TIMING

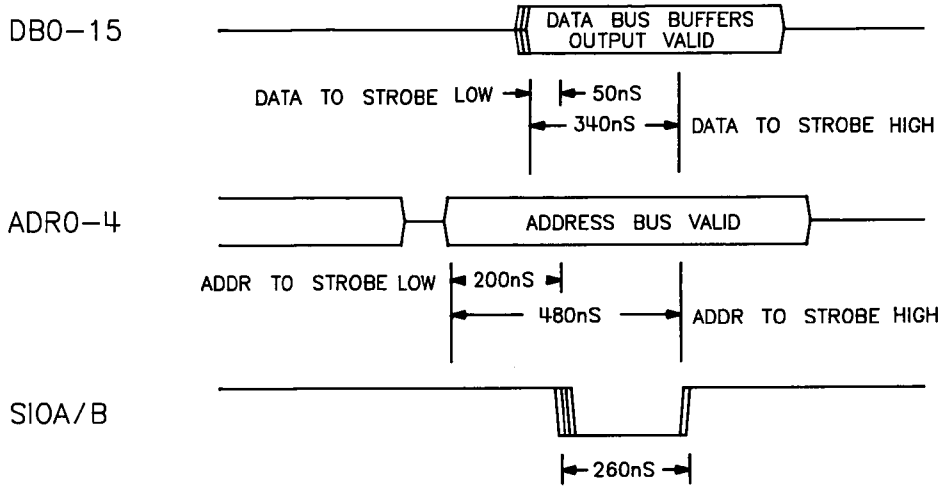

I/O BUS READ CYCLE TIMING

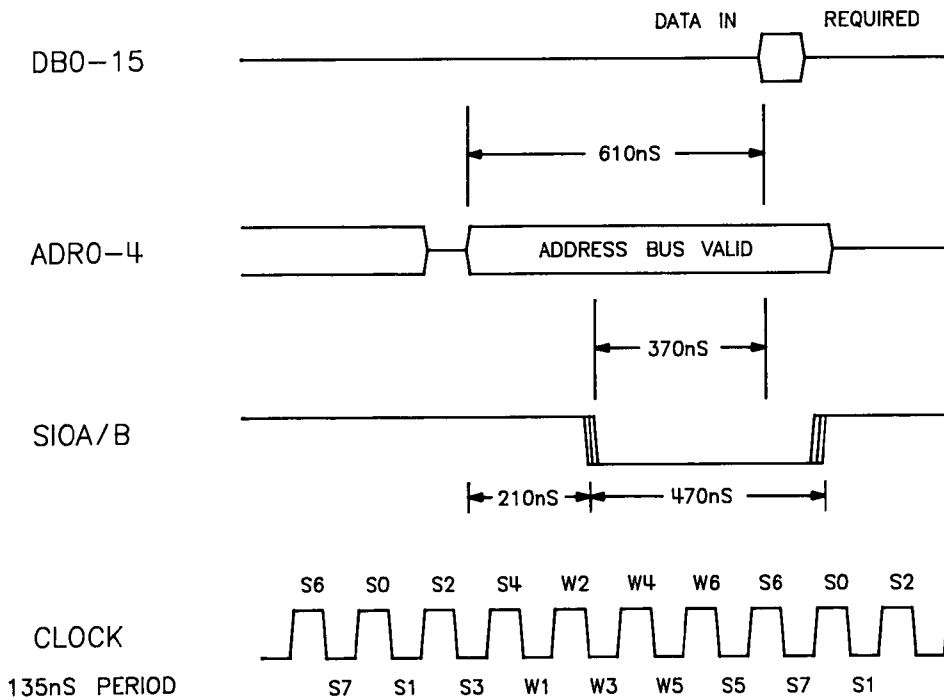

Figure A60-2. I/O Bus Write Cycle and Read Cycle Timing Diagrams

POWER UP/STOP (BLOCK O)

At power on, the HPUP control signal is high, which triggers the input comparator to output an active high. The comparator output biases a transistor and capacitor, providing the slight delay required by the microprocessor.

Output comparators provide the microprocessor and HP-IB reset signals (LRESET and LSTP), after the required delay.

Transistors Q2 and Q3 protect the RAM devices if instrument AC power or DC supply is lost.

I/O ADDRESS BUS (BLOCK P)

An address latch interfaces the instrument address bus with the I/O address bus. Five I/O address lines and two main control signals (SIOA and SIOB) form the I/O address bus.

A60 Processor Component-Level Troubleshooting

TYPES OF TROUBLESHOOTING

There are several types of troubleshooting for the A60 processor assembly:

- **Input Signal Verification.** This test checks several processor assembly input signals and should be performed prior to doing any in-depth troubleshooting.
- **Self Test.** Self test runs when you turn the instrument on or when you press **[INSTR PRESET]**. Two front panel LEDs (INSTR CHECK I and INSTR CHECK II) provide a visual indication of the self check results.
- **SHIFT M4.** When you initiate this diagnostic, you can check the operation of specific circuitry on the A60 processor assembly.
- **Destructive RAM Test.** This test exhaustively tests RAM and completely verifies EEPROM operation.
- **HP-IB Verification.** The A60 assembly HP-IB circuitry is contained in one block of circuitry on the schematic, to facilitate troubleshooting.

INPUT SIGNAL VERIFICATION

When to Use Input Signal Verification

Use input signal verification prior to in-depth troubleshooting of the A60 assembly. Verification consists of measuring all input signals to the A60 assembly, in addition to a few key signals that are required to run self test.

Equipment Required

A DVM and/or an oscilloscope.

Procedure

NOTE: The A60 processor is a static sensitive assembly. Work only at an anti-static work station.

1. Turn line power off. Place the A60 processor assembly on an extender.
2. Turn line power on.
3. Using A60TP7 or A60TP17 as ground, verify the voltages in Table A60-2.

A60 Processor Component-Level Troubleshooting

Table A60-2. Input Signal Voltages

Measurement Point	Voltage
A60TP11 (LSTP)	+5V*
A60TP21 (+5V)	+5V
A60TP22 (HRAMPUP)	+5V
A60TP23 (LRESET)	+5V
A60P1-33 (Vpp)	+4.5V
A60U38 Pin 23 (VRAM)	+5V
A60U1 Pin 8 (VREF)	+1.2V
+5PF (anode of A60CR1 or A60CR4)	+5V

* A microprocessor failure can cause LSTP to be low.

4. Verify the following waveforms:

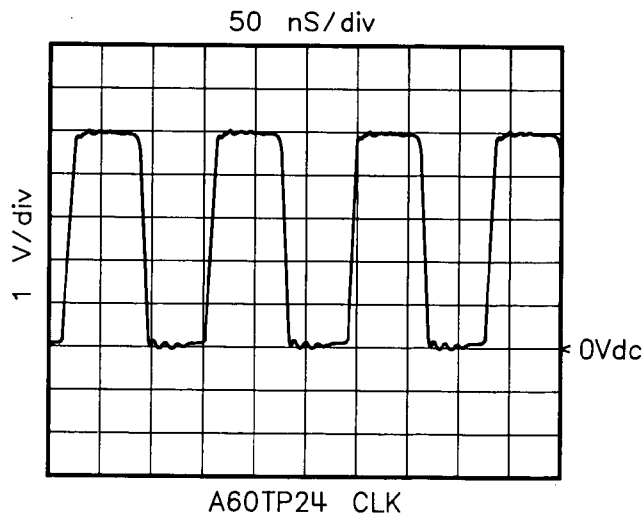
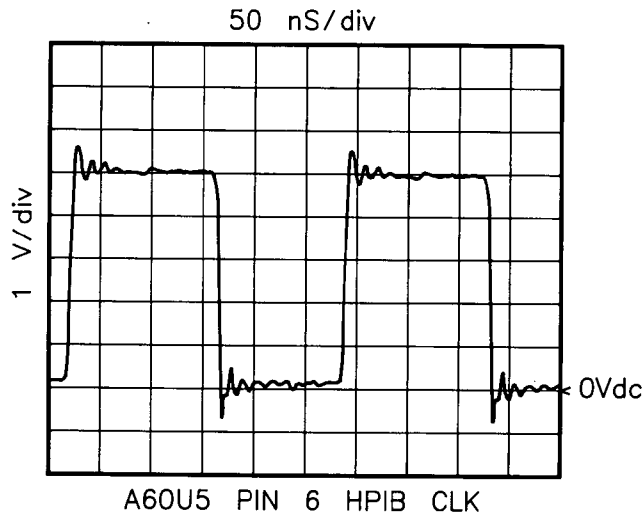

SELF TESTS

What are Self Tests

At power on and at instrument preset, self test performs diagnostic checks on some of the instrument circuitry. The tests performed are the SHIFT M4 tests 0 through 8, and 10 through 13 (described under **SHIFT M4**). If the destructive RAM test is activated, self test also performs SHIFT M4 tests number 7 and 8 (see **DESTRUCTIVE RAM TEST**).

Figure A60-3 shows the instrument self test flow chart.

How to Check the Results of Self Test

You can check the results of instrument self test in 3 ways:

- On the INSTR CHECK LEDs I and II
- Using the A60 Processor Self Test LEDs
- Using the diagnostic SHIFT M4

NOTE: The most accurate failure indication is given by the A60 processor self test LEDs. A failure can occur that invalidates the indication of the INSTR CHECK LEDs and SHIFT M4.

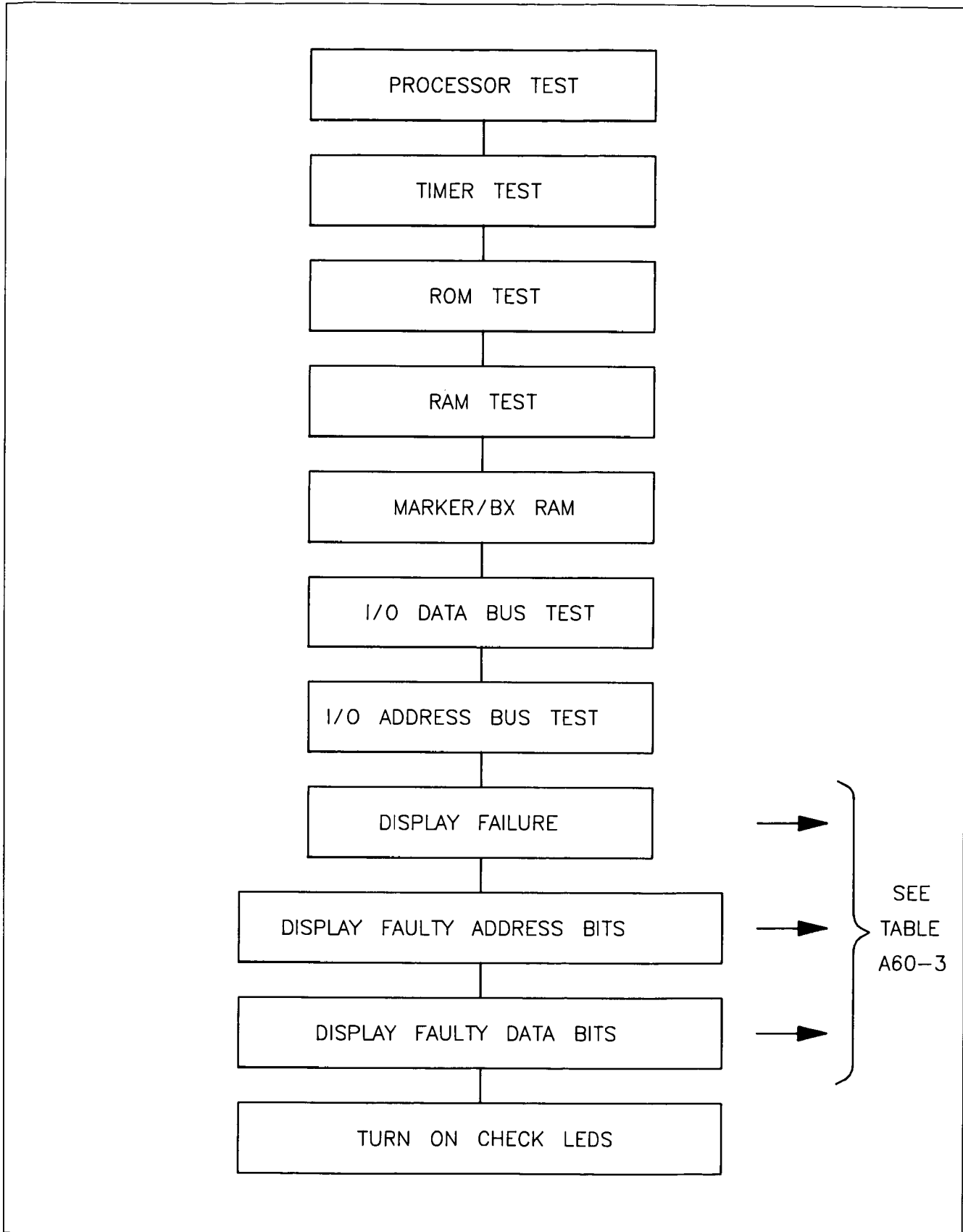

Figure A60-3. Self Test Flow Chart

Instrument Check LEDs I and II

The INSTR CHECK LEDs I and II are the easiest failure indicators to check because they are located on the front panel, adjacent to the [INSTR PRESET] key.

1. Switch on power or press [INSTR PRESET].

Both INSTR CHECK LEDs turn on.

LED I turns off when the processor, memory, and peripheral interface timer (on the A60 assembly) pass self test (SHIFT M4 tests 0 through 6, 10, and 11).

LED II turns off when the I/O address bus, I/O data bus, and marker RAM pass self test (SHIFT M4 tests 9, 12, and 13).

If no failure occurs, both LEDs are off after approximately 1 second. If either LED remains on, check the 16 LEDs on the A60 assembly. Remember that it is possible for a failure to occur that causes both INSTR CHECK LEDs to go off when they shouldn't.

A60 PROCESSOR SELF TEST LEDs

There are 16 self test LEDs at the top of the A60 assembly that turn on when you switch the power on or press [INSTR PRESET]. If there is no failure, all 16 LEDs light and approximately 1 second later, turn off.

1. If self test fails, cycle the line power or press [INSTR PRESET] and observe the processor self test LEDs.

All 16 LEDs turn on.

After 2 seconds:

A60DS15 and A60DS16 (the LEDs closest to the front panel) turn off.

A60DS1 through A60DS14 indicate the failure (see Table A60-3).

After 4 seconds:

A60DS9 through A60DS15 turn off and A60DS16 turns on.

A60DS1 through A60DS8 then indicate which I/O address bus line failed (see Table A60-2).

After 6 seconds:

A60DS1 through A60DS16 indicate which I/O data bus line failed (see Table A60-3).

Table A60-3. A60 Self test LEDs - Failure Indications

A60 Processor Self Test LEDs (Time After Power On or [INSTR PRESET])				
A60 Processor LED	First 2 Seconds		Second 2 Seconds	Afterward
	SHIFT M4 Test #	Test Name	I/O Address Bus Test	I/O Data Bus Test
DS1	0	PROCESSOR	ADR0	DB0
DS2	1	ROM U37	ADR1	DB1
DS3	2	ROM U36	ADR2	DB2
DS4	3	ROM U35	ADR3	DB3
DS5	4	ROM U34	ADR4	DB4
DS6	5	RAM U39	SIOA	DB5
DS7	6	RAM U38	SIOB	DB6
DS8	7	EEPROM U33	SIOA	DB7
DS9	8	EEPROM U32	OFF	DB8
DS10	9	MKR BX RAM	OFF	DB9
DS11	10	TMR LEDS U4	OFF	DB10
DS12	11	TMR U4	OFF	DB11
DS13	12	I/O ADRS	OFF	DB12
DS14	13	I/O DATA	OFF	DB13
DS15		OFF	OFF	DB14
DS16		OFF	ON	DB15

SHIFT M4

When to Use SHIFT M4

After you have determined the failure mode (using the processor self test LEDs and Table A60-3), you can use the SHIFT M4 diagnostic to further isolate the failure. This service diagnostic tests DACs and control circuitry in the instrument, and allows the results of the self test to be displayed in the front panel ENTRY DISPLAY.

What SHIFT M4 Does

SHIFT M4 does not perform exhaustive DAC tests, but provides an indication to direct your troubleshooting to a specific device or circuit path.

Table A60-4 lists all the tests performed when you press **[SHIFT][M4]**. As you can see, this service diagnostic tests more than just the A60 assembly. All of the tests are listed because only one test (0) is not dependent on the test results of one or more of the other tests.

NOTE: SHIFT M4 does not automatically run tests 7 and 8 (EEPROM 1 RD/WR and EEPROM 2 RD/WR) see **DESTRUCTIVE RAM TEST** for details.

The Interdependency of the SHIFT M4 Tests

Table A60-5 illustrates the interdependency of the SHIFT M4 tests. The vertical axis (Test Number) lists the tests, 0 through 31. The horizontal axis (Dependent On) lists the test numbers and indicates which test(s) must pass for a given test result to be valid. An **X** in a Dependent On column indicates that a given test is valid only if the test in that column also passes.

Example:

Test 11 is only valid if tests 0, 5, and 6 pass. If test 11 fails, verify that tests 0, 5, and 6 have passed **before** troubleshooting the circuitry exercised in test 11.

SHIFT M4 Test Procedure

1. Press **[SHIFT][M4]**.

While the tests are running, the ENTRY DISPLAY shows **DIAGNOSTIC TESTS IN PROGRESS**.

When the tests are through, the instrument displays **TEST:?FULL DIAGNOSTIC** and then displays **PASS** or **FAIL**. **PASS** indicates that all of the tests related to this diagnostic have passed. **FAIL** indicates that one or more of the tests failed.

2. If the display indicates **FAIL**, use the RPG or the step keys to move through the test results and determine which test(s) failed.

Table A60-4. Diagnostic SHIFT M4 Tests (1 of 2)

Number	Name	Description
0	PROCESSOR TST	Verifies the operation of the Processor (A60 Block E), the Free Run DSA (A60 Block F), A60U25A, A60U25D, the processor's data and address bus, and a portion of the UV-EROM (A60 Block A) and A60U29.
1	ROM 1 CKSUM	Verifies the operation (checksum) of A60U37.
2	ROM 2 CKSUM	Verifies the operation (checksum) of A60U36.
3	ROM 3 CKSUM	Verifies the operation (checksum) of A60U35.
4	ROM 4 CKSUM	Verifies the operation (checksum) of A60U34.
5	RAM 1 RD/WR	Verifies the operation (read/write) of A60U39 and a portion of A60U29.
6	RAM 2 RD/WR	Verifies the operation (read/write) of A60U38 and a portion of A60U29.
7	EEROM 1 RD/WR	Verifies the operation (read/write) of A60U33 and a portion of A69U29. Note that this test is only performed if A60TP1 RAM is grounded (initiates the Destructive RAM test).
8	EEROM 2 RD/WR	Verifies the operation (read/write) of A60U32 and a portion of A60U29. Note that this test is only performed if A60TP1 RAM is grounded (initiates the Destructive RAM test).
9	MKR RAM RD/WR	Verifies the operation (read/write) of the Address Register (A57 Block A), the Sweep Event Memory (A57 Block B), the Read/Write RAM Buffer (A57 Block C), and the Microprocessor Read/Write Strokes (A57 Block K).
10	PIT (LED Registers)	Verifies the operation of A60U4 and a portion of A60U29.
11	PIT RESPONDS	Verifies the operation of A60U4 and a portion of A60U29.
12	I/O ADDR BUS	Verifies the operation of the I/O address Bus (A60 Block K), A60U22, the I/O Address bus, and a portion of the I/O Decoding and Control (A60 Block J) and A60U29.
13	I/O DATA BUS	Verifies the operation of the I/O Data Bus Buffers (A60 Block P), A60U14, A60U16, the I/O Data Bus, and a portion of the I/O Decoding and Control (A60 Block J) and A60U29.
14	A-D CONVERTER	Verifies the operation of the ADC Control Latch (A27 Block L), the ADC Clock/Control (A27 Block M), the ADC Input Multiplexer (A27 Block N), the Test ADC (A27 Block O), the ADC Window Comparator (A27 Block P), the Conversion Complete Timer/SRQ Latch (A27 Block Q), and the Status Buffer (A27 Block R). The Address Decoding (A27 Block B) is partially verified.
15	LEVEL REF DAC	Verifies the operation of the ALC Reference Generator (A27 Block H) and a portion of the Address Decoding (A27 Block B). Monitors LVL (A27 Block H output) to determine the test results.
16	MAN SWP DAC	Verifies the operation of the Manual Sweep Dac (A57 Block G) and a portion of the Microprocessor And Read Write Strokes (A57 Block K). Monitors LVL SWP (A27 Block I output) to determine the test results.

Table A60-4. Diagnostic SHIFT M4 Tests (2 of 2)

Number	Name	Description
17	MARKER RAMP	Verifies the operation of the A58 Sweep Generator assembly. Monitors BVSWP (A58 Block O Output) to determine the test results.
18	RESET DAC	Verifies the operation of the A58 Sweep Generator assembly. This test specifically exercises the Reset DAC (A57 Block C) and monitors BVSWP (A58 Block O output) to determine the test results.
19	LEVEL SWP DAC	Verifies the operation of the Power Sweep Generator (A27 Block I) and a portion of the Address Decoding (A27 Block B). Monitors LVL SWP (A27 Block I output) to determine the test results.
20	BND CROSS DAC	Verifies the operation of the Sweep Comparator (A57 Block D) and a portion of A57U24 and A57U28. Monitors CMP (A57 Block I input) to determine the test results.
21	SWP WIDTH DAC	Verifies the operation of the A58 Sweep Generator assembly. This test specifically exercises the Sweep Width DAC (A58 Block M) and monitors BVSWP (A58 Block O output) to determine the test results.
22	SWP RANGE ATN	Verifies the operation of the A58 Sweep Generator assembly. This test specifically exercises the Sweep Width Register (A58 Block E) and monitors BVSWP (A58 Block O output) to determine the test results.
23	V/GHz CIRCUIT	Verifies the operation of the -0.25 V/GHz circuitry (A28 Block E) and a portion of the Programmable Scalar (A28 Block D) and the Digital Control (A28 Block I). Monitors $-.25$ V/GHz (A28 Block E output) to determine the test results.
24	V/GHz BND ATN	Verifies the operation of the Programmable Scalar (A28 Block D), A28U19 and a portion of A28U16. Monitors $-.25$ V/GHz (A28 Block E output) to determine the test results.
25	BRK PNT 1 DAC	Verifies the operation of the 9 GHz Breakpoint Slope Compensation (A27 Block D), the Compensation Summing Amplifier (A27 Block G), and a portion of the Address Decoding (A27 Block B). Monitors LVL COR (A27 Block G output) to determine the test results.
26	BRK PNT 2 DAC	Verifies the operation of the 20 GHz Breakpoint Slope Compensation (A27 Block C), the Compensation Summing Amplifier (A27 Block G), and a portion of the Address Decoding (A27 Block B). Monitors LVL COR (A27 Block G output) to determine the test results.
27	ATN SLOPE DAC	Verifies the operation of the Attenuator Slope Compensation (A27 Block E), the Compensation Summing Amplifier (A27 Block G), and a portion of the Address Decoding (A27 Block B). Monitors LVL COR (A27 Block G output) to determine the test results.
28	YO PRETUN DAC	Verifies the operation of the Pretune Register (A54 Block A), the Pretune DAC (A54 Block B), and the Summing Amplifier (A54 Block C). Monitors $-.25$ V/GHz (A28 Block E output) to determine the test results.
29	SWEETIME DAC	Verifies the operation of the A58 Sweep Generator assembly. This test specifically exercises the Sweep Time DAC (A58 Block G) and uses the A57 Marker Bandcross assembly and the PIT (A60U4) to determine the test results.
30	NOT USED	
31	A27 INSTALLED	Verifies that the A27 Level Control Assembly is installed.

Table A60-5. SHIFT M4 Test Interdependence

Test Number	Dependent On Test Number											
	0	5	6	9	11	12	13	14	15	17	20	31
0												
1	X											
2	X											
3	X											
4	X											
5	X											
6	X											
7	X	X	X									
8	X	X	X									
9	X	X	X			X	X					
10	X	X	X									
11	X	X	X									
12	X	X	X									
13	X	X	X									
14	X	X	X			X	X	X				
15	X	X	X			X	X	X				X
16	X	X	X			X	X	X	X			X
17	X	X	X			X	X	X	X			X
18	X	X	X			X	X	X	X			X
19	X	X	X			X	X	X	X			X
20	X	X	X			X	X	X				X
21	X	X	X			X	X	X	X			X
22	X	X	X			X	X	X	X			X
23	X	X	X			X	X	X	X			X
24	X	X	X			X	X	X	X			X
25	X	X	X			X	X	X	X			X
26	X	X	X			X	X	X	X			X
27	X	X	X			X	X	X	X			X
28	X	X	X			X	X	X	X			X
29	X	X	X	X	X	X	X	X	X	X	X	X
30												
31	X											

DESTRUCTIVE RAM TEST

**CAUTION**

This test totally erases the instrument state Save registers in random access memory (RAM). Use this test only if a failure occurs with the instrument state Save/Recall registers or if the calibration data is defaulted (CAL FAULT) or continually exhibits incorrect values.

Functions of the Destructive RAM Test

This test has two functions:

1. To exhaustively test RAM.
2. To completely verify EEPROM operation.

Because of the limited write lifetime of EEPROM, and because of the loss of information in RAM, this test is not automatically part of either the self test performed at power on (or instrument PRESET), or the diagnostics run using SHIFT M4 (tests 7 and 8).

Procedure

1. Connect a jumper between A60TP1 (RAM) and A60TP7 (GND).
2. Cycle the line power, or press **[INSTR PRESET]**.
3. Wait for the entire test to complete (4 to 5 minutes).
3. Remove the jumper between A60TP1 (RAM) and A60TP7 (GND).
4. Check the A60 processor self test LEDs for failure indications. Note that if a failure occurs in RAM, the EEPROMs are not tested. The EEPROM tests (7 and 8) require that the RAM tests (5 and 6) pass first.

How Calibration Data Can be Restored

RAM holds the working calibration data and the SAVE/RECALL register values. If calibration data and the register values are lost, protected calibration data stored in EEPROM loads into RAM and the instrument displays **CALIBRATION RESTORED**, when you turn the instrument on. The register values, however, can not be recovered.

HP-IB VERIFICATION

Block G contains the HB-IB circuitry on the A60 assembly. If the instrument fails the HP-IB verification procedure due to an A60 problem, troubleshoot this block.

BATTERY REPLACEMENT

What the Battery Does

The processor assembly battery (A60B1) provides backup power to RAM, which holds the working calibration data and the SAVE/RECALL register values.

How Calibration Data is Restored

If the battery is defective, or is replaced, the calibration data and the register values are lost. If RAM does lose its information, the next time you turn the instrument on, protected calibration data stored in EEPROM loads into RAM and the instrument displays **CALIBRATION RESTORED**. Note, however, that register values are not restored.

How Long Should the Battery Last

The battery provides at least two years of back up power, and has a shelf life exceeding 10 years. It is not rechargeable.

WARNING

Although the battery has a strong outer case, do not abuse it mechanically, electrically, or thermally. This battery contains lithium and thionyl chloride (SOCL₂) and can be a fire, explosion, and severe burn hazard if abused.

Lithium can burn or explode on contact with moisture.

Thionyl chloride is highly toxic. On contact with air, it partially breaks down into hydrochloric acid and sulfur dioxide fumes, which are toxic, extremely repulsive, strongly irritating, and corrosive to eyes, skin, lungs, and mucous membranes. If a person comes in contact with or breathes this material, CONTACT A POISON CONTROL CENTER OR DOCTOR IMMEDIATELY.

Do not try to charge this battery; it may rupture.

Do not attempt to open the battery, heat it above 212° F (100° C), expose its contents to water, or incinerate it.

Your local laws may require the disposal of thionyl chloride or lithium in a chemical waste disposal site. You can return the battery to: Hewlett-Packard, 1400 Fountaingrove Parkway, Santa Rosa, California 95401, Attention: Environmental Engineering Department.

Dead batteries have converted most of the lithium and thionyl chloride into not-toxic chemicals.

How to Replace the Battery



CAUTION

This assembly contains static sensitive components. Work at a bench equipped with an anti-static surface, and wear a grounding strap that provides a path to earth ground of between 1 and 2.5 M Ω . Always handle a printed circuit board by the edges; never touch the finger contacts.

Do not set the A60 assembly on bare metal; this can short out and cause damage to a good battery.

1. Turn the line switch off and disconnect the instrument power cord. Wait 3 minutes.
2. Remove the A60 processor assembly.
3. Remove the battery and dispose of it properly (see WARNING, above).
4. Check the new battery before installing it; place a 10K ohm resistor across the battery and measure the voltage across the resistor. The voltage should be at least 3.4V (typically 3.6V).
5. If the voltage is correct, install the new battery in the processor assembly.
6. Reinstall the processor assembly in the instrument. Reconnect the power cord, and turn the instrument on. The front panel ENTRY display reads **CALIBRATION RESTORED**.
7. Verify that TP26 (IBATT) is less than 3 mV. A larger voltage indicates excessive battery drain.
8. Replace the top cover.

A60 Processor Component-Level Troubleshooting

Table A60-6. A60 Processor P1 Pin I/O (1 of 3)

Pin	Mnemonic	Levels	Source	Destination
1 56	GND PLANE GND PLANE	0V 0V	INSTRUMENT GROUND INSTRUMENT GROUND	*L *L
2 57	REN DIO1	TTL (LOW TRUE) TTL	A62J7-10 D	D A62J7-1
3 58	IFC DIO2	TTL (LOW TRUE) TTL	A62J7-17 D	D A62J7-3
4 59	NDAC DIO3	TTL TTL	D D	A62J7-15 A62J7-5
5 60	NRFD DIO4	TTL TTL	D D	A62J7-13 A62J7-7
6 61	DAV DIO5	TTL TTL	D D	A62J7-11 A62J7-2
7 62	EOI DIO6	TTL TTL	D D	A62J7-9 A62J7-4
8 63	ATN DIO7	TTL TTL	D D	A62J7-21 A62J7-6
9 64	SRQ DIO8	TTL TTL	A62J7-19 D	D A62J7-8
10 65	LSTP	TTL (LOW TRUE)	XA59P1-65	D A62J1-43
11 66				
12 67				
13 68				
14 69	LIPS	TTL (LOW TRUE)	XA52P1-36/A62J1-19	*E
15 70	SIOA GND PLANE	TTL (LOW TRUE) 0V	*G INSTRUMENT GROUND	*J *L
16 71	SIOB GND PLANE	TTL (LOW TRUE) 0V	*G INSTRUMENT GROUND	*J *L
17 72	ADRO GND PLANE	TTL 0V	*G INSTRUMENT GROUND	*J *L
18 73	ADR2 ADR1	TTL TTL	*G *G	*J *J
19 74	ADR4 ADR3	TTL TTL	*G *G	*J *J

A single letter in the source or destination column refers to a function block on this assembly schematic.

An asterisk (*) denotes multiple sources or destinations; refer to the A62 motherboard wiring list for a complete representation of signal sources and destinations.

Table A60-6. A60 Processor P1 Pin I/O (2 of 3)

Pin	Mnemonic	Levels	Source	Destination
20 75	DB0 GND PLANE	TTL 0V	*J K I INSTRUMENT GROUND	*I K *L
21 76	DB2 DB1	TTL TTL	*I K *I K	*I K *I K
22 77	DB4 DB3	TTL TTL	*I K *I K	*I K *I K
23 78	DB6 DB5	TTL TTL	*I K *I K	*I K *I K
24 79	DB8 DB7	TTL TTL	*J K I *I K	*I K *I K
25 80	DB10 DB9	TTL TTL	*J K I *J K L	*I K *I K
26 81	DB12 DB11	TTL TTL	*J K I *J K I	*I K *I K
27 82	DB14 DB13	TTL TTL	*J K L *J K I	*I K *I K
28 83	DB15	TTL	*J K I	*I K
29 84				
39 85				
31 86				
32 87				
33 88				
34 89	5 MHZ CLK LSRQ	TTL TTL (LOW TRUE)	B *	C F XA59P1-34 *I
35 90	+20V +20V	+20V +20V	XA52P1-16, 40 XA52P1-16, 40	*NOT USED *NOT USED
36 91	+5.2V +12V	+5.2V +12V	XA52P1-17, 18, 41, 42 XA52P1-9, 33	*L *L
37 92	+5.2V +5.2V	+5.2V +5.2V	XA52P1-17, 18, 41, 42 XA52P1-17, 18, 41, 42	*L *L

A single letter in the source or destination column refers to a function block on this assembly schematic.

An asterisk (*) denotes multiple sources or destinations; refer to the A62 motherboard wiring list for a complete representation of signal sources and destinations.

A60 Processor Component-Level Troubleshooting

Table A60-6. A60 Processor P1 Pin I/O (3 of 3)

Pin	Mnemonic	Levels	Source	Destination
38 93	-15V -5.2V	-15V -5.2V	XA56P1-15, 30 XA53P1-18, 36	*NOT USED *L
39 94	-10V -10V	-10V -10V	XA53P1-12, 13, 31, 32 XA53P1-12, 13, 31, 32	*NOT USED *NOT USED
40 95	GND PLANE HPUP	0V TTL (HIGH TRUE)	INSTRUMENT GROUND XA52P1-46	*L *NOT USED
41 96	GND PLANE GND PLANE	0V 0V	INSTRUMENT GROUND INSTRUMENT GROUND	*L *L
42 97	GND PLANE GND PLANE	0V 0V	INSTRUMENT GROUND INSTRUMENT GROUND	*L *L
43 98	GND PLANE GND PLANE	0V 0V	INSTRUMENT GROUND INSTRUMENT GROUND	*L *L
44 99	GND PLANE GND PLANE	0V 0V	INSTRUMENT GROUND INSTRUMENT GROUND	*L *L
45 100	HSTM GND PLANE	TTL (HIGH TRUE) 0V	H INSTRUMENT GROUND	XA61P1-45 *L
46 101	LSOB LWRT	TTL (LOW TRUE) TTL (LOW TRUE)	H H	XA61P1-46 XA61P1-101
47 102	LIDA14 LIDA15	TTL (LOW TRUE) TTL (LOW TRUE)	 	XA61P1-47 XA61P1-102
48 103	LIDA12 LIDA13	TTL (LOW TRUE) TTL (LOW TRUE)	 	XA61P1-48 XA61P1-103
49 104	LIDA10 LIDA11	TTL (LOW TRUE) TTL (LOW TRUE)	 	XA61P1-49 XA61P1-104
50 105	LIDA8 LIDA9	TTL (LOW TRUE) TTL (LOW TRUE)	 	XA6P1-50 XA61P1-105
51 106	LIDA6 LIDA7	TTL (LOW TRUE) TTL (LOW TRUE)	 	XA61P1-51 XA61P1-106
52 107	LIDA4 LIDA5	TTL (LOW TRUE) TTL (LOW TRUE)	 	XA61P1-52 XA61P1-107
53 108	LIDA2 LIDA3	TTL (LOW TRUE) TTL (LOW TRUE)	 	XA61P1-53 XA6P1-108
54 109	LIDA0 LIDA1	TTL (LOW TRUE) TTL (LOW TRUE)	 	XA61P1-54 XA61P1-109
55 110	GND PLANE GND PLANE	0V 0V	INSTRUMENT GROUND INSTRUMENT GROUND	*L *L

A single letter in the source or destination column refers to a function block on this assembly schematic.

An asterisk (*) denotes multiple sources or destinations; refer to the A62 motherboard wiring list for a complete representation of signal sources and destinations.

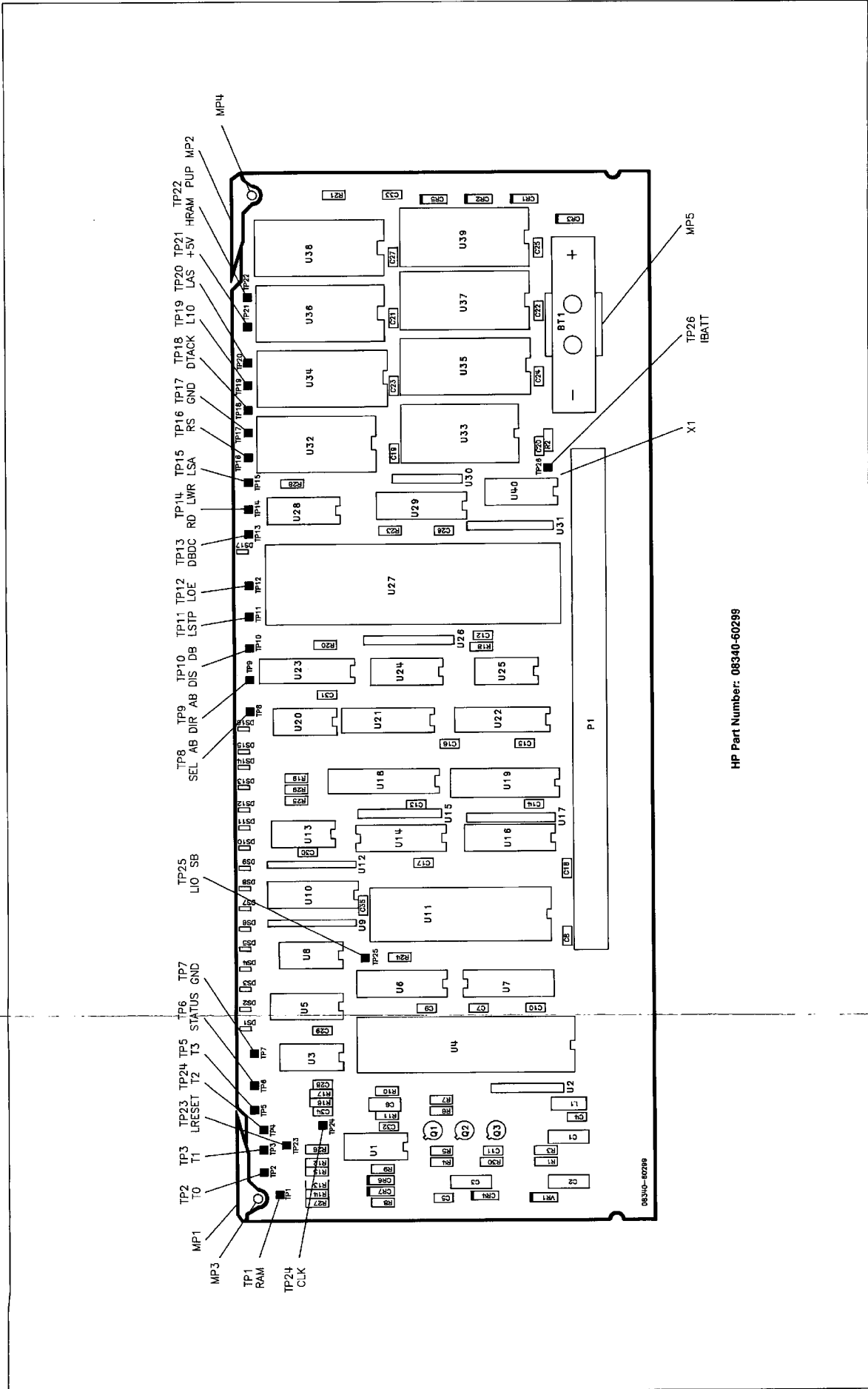

HP Part Number: 08340-60299

Figure A60-4. A60 Processor Component Location Diagram
A60-26 Controller

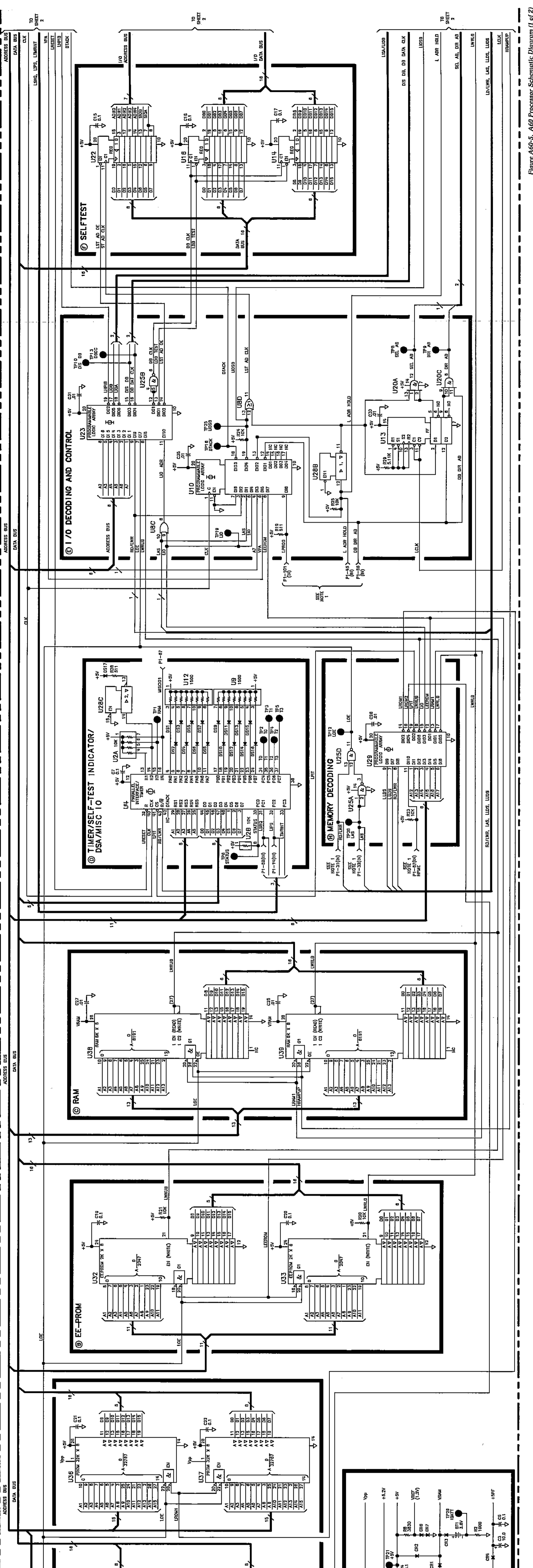

Figure A60-5. A60 Processor Schematic Diagram (1 of 2)
Controller A60-27/A60-28

A60 Processor Component-Level Troubleshooting

Table A60-7. A60 Processor Replaceable Parts

Reference Designation	HP Part Number	C D	Qty	Description	Mfr Code	Mfr Part Number
A60	08340-60299	8	1	PROCESSOR ASSEMBLY	28480	08340-60299
A60	08340-60331	9	1	PROCESSOR ASSEMBLY SERVICE KIT	28480	08340-60331
A60BT1	1420-0331	3	1	BATTERY 3.4V 1.75A-HR LITHIUM THIONYL	28480	1420-0331
A60C1	0180-0374	3	3	CAPACITOR-FXD 10UF ± 10% 20VDC TA	56289	150D106X9020B2
A60C2	0180-0374	3		CAPACITOR-FXD 10UF ± 10% 20VDC TA	56289	150D106X9020B2
A60C3	0180-0374	3		CAPACITOR-FXD 10UF ± 10% 20VDC TA	56289	150D106X9020B2
A60C4	0160-4835	7	19	CAPACITOR-FXD .1UF ± 10% 50VDC CER	28480	0160-4835
A60C5	0160-4835	7		CAPACITOR-FXD .1UF ± 10% 50VDC CER	28480	0160-4835
A60C6	0180-0291	3	1	CAPACITOR-FXD 1UF ± 10% 35VDC TA	56289	150D105X9035A2
A60C7	0160-4835	7		CAPACITOR-FXD .1UF ± 10% 50VDC CER	28480	0160-4835
A60C8	0160-4835	7		CAPACITOR-FXD .1UF ± 10% 50VDC CER	28480	0160-4835
A60C9	0160-4835	7		CAPACITOR-FXD .1UF ± 10% 50VDC CER	28480	0160-4835
A60C10	0160-4835	7		CAPACITOR-FXD .1UF ± 10% 50VDC CER	28480	0160-4835
A60C11	0160-4832	4	11	CAPACITOR-FXD .01UF ± 10% 100VDC CER	28480	0160-4832
A60C12	0160-4835	7		CAPACITOR-FXD .1UF ± 10% 50VDC CER	28480	0160-4835
A60C13	0160-4835	7		CAPACITOR-FXD .1UF ± 10% 50VDC CER	28480	0160-4835
A60C14	0160-4835	7		CAPACITOR-FXD .1UF ± 10% 50VDC CER	28480	0160-4835
A60C15	0160-4835	7		CAPACITOR-FXD .1UF ± 10% 50VDC CER	28480	0160-4835
A60C16	0160-4835	7		CAPACITOR-FXD .1UF ± 10% 50VDC CER	28480	0160-4835
A60C17	0160-4835	7		CAPACITOR-FXD .1UF ± 10% 50VDC CER	28480	0160-4835
A60C18	0160-4835	7		CAPACITOR-FXD .1UF ± 10% 50VDC CER	28480	0160-4835
A60C19	0160-4835	7		CAPACITOR-FXD .1UF ± 10% 50VDC CER	28480	0160-4835
A60C20	0160-4835	7		CAPACITOR-FXD .1UF ± 10% 50VDC CER	28480	0160-4835
A60C21	0160-4835	7		CAPACITOR-FXD .1UF ± 10% 50VDC CER	28480	0160-4835
A60C22	0160-4835	7		CAPACITOR-FXD .1UF ± 10% 50VDC CER	28480	0160-4835
A60C23	0160-4835	7		CAPACITOR-FXD .1UF ± 10% 50VDC CER	28480	0160-4835
A60C24	0160-4835	7		CAPACITOR-FXD .1UF ± 10% 50VDC CER	28480	0160-4835
A60C25	0160-4832	4		CAPACITOR-FXD .01UF ± 10% 100VDC CER	28480	0160-4832
A60C26	0160-4832	4		CAPACITOR-FXD .01UF ± 10% 100VDC CER	28480	0160-4832
A60C27	0160-4832	4		CAPACITOR-FXD .01UF ± 10% 100VDC CER	28480	0160-4832
A60C28	0160-4832	4		CAPACITOR-FXD .01UF ± 10% 100VDC CER	28480	0160-4832
A60C29	0160-4832	4		CAPACITOR-FXD .01UF ± 10% 100VDC CER	28480	0160-4832
A60C30	0160-4832	4		CAPACITOR-FXD .01UF ± 10% 100VDC CER	28480	0160-4832
A60C31	0160-4832	4		CAPACITOR-FXD .01UF ± 10% 100VDC CER	28480	0160-4832
A60C32	0160-4832	4		CAPACITOR-FXD .01UF ± 10% 100VDC CER	28480	0160-4832
A60C33	0160-4832	4		CAPACITOR-FXD .01UF ± 10% 100VDC CER	28480	0160-4832
A60C34	0160-4801	7	1	CAPACITOR-FXD 100PF ± 5% 100VDC CER	28480	0160-4801
A60C35	0160-4832	4		CAPACITOR-FXD .01UF ± 10% 100VDC CER	28480	0160-4832
A60CR1	1901-0376	6	2	DIODE-GEN PRP 35V 50MA DO-35	28480	1901-0376
A60CR2	1901-0376	6		DIODE-GEN PRP 35V 50MA DO-35	28480	1901-0376
A60CR3	1901-0518	8	1	DIODE-SM SIG SCHOTTKY	28480	1901-0518
A60CR4	1901-0050	3	2	DIODE-SWITCHING 80V 200MA 2NS DO-35	28480	1901-0050
A60CR5	1901-0050	3		DIODE-SWITCHING 80V 200MA 2NS DO-35	28480	1901-0050
A60CR6	1901-1098	1	2	DIODE-SWITCHING 50V 200MA 4NS	02682	1N4150
A60CR7	1901-1098	1		DIODE-SWITCHING 50V 200MA 4NS	02682	1N4150
A60DS1	1990-1149	0	16	LED-LAMP IF=7MA-MAX BVR=5V	28480	1990-1149
A60DS2	1990-1149	0		LED-LAMP IF=7MA-MAX BVR=5V	28480	1990-1149
A60DS3	1990-1149	0		LED-LAMP IF=7MA-MAX BVR=5V	28480	1990-1149
A60DS4	1990-1149	0		LED-LAMP IF=7MA-MAX BVR=5V	28480	1990-1149
A60DS5	1990-1149	0		LED-LAMP IF=7MA-MAX BVR=5V	28480	1990-1149
A60DS6	1990-1149	0		LED-LAMP IF=7MA-MAX BVR=5V	28480	1990-1149
A60DS0	1990-1149	0		LED-LAMP IF=7MA-MAX BVR=5V	28480	1990-1149
A60DS8	1990-1149	0		LED-LAMP IF=7MA-MAX BVR=5V	28480	1990-1149
A60DS9	1990-1149	0		LED-LAMP IF=7MA-MAX BVR=5V	28480	1990-1149
A60DS10	1990-1149	0		LED-LAMP IF=7MA-MAX BVR=5V	28480	1990-1149
A60DS11	1990-1149	0		LED-LAMP IF=7MA-MAX BVR=5V	28480	1990-1149
A60DS12	1990-1149	0		LED-LAMP IF=7MA-MAX BVR=5V	28480	1990-1149
A60DS13	1990-1149	0		LED-LAMP IF=7MA-MAX BVR=5V	28480	1990-1149
A60DS14	1990-1149	0		LED-LAMP IF=7MA-MAX BVR=5V	28480	1990-1149
A60DS15	1990-1149	0		LED-LAMP IF=7MA-MAX BVR=5V	28480	1990-1149
A60DS16	1990-1149	0		LED-LAMP IF=7MA-MAX BVR=5V	28480	1990-1149
A60DS17	1990-1148	9	1	LED-LAMP LUM-INT=1MCD IF=20MA-MAX BVR=5V	28480	1990-1148
A60L1	9100-1788	6	1	CHOKE-WIDE BAND ZMAX=680 OHM@ 180 MHZ	02114	VK200 20/48
A60MP1	4040-0754	1	1	EXTR PC BD BLU	28480	4040-0754
A60MP2	4040-0748	3	1	EXTR PC BD BLK	28480	4040-0748
A60MP3,4	1480-0073	6	2	PIN-ROLL .062-IN-DIA .25-IN-LG BE-CU	28480	1480-0073
A60MP5	1400-1267	4	1	CLIP BTRY AA	28480	1400-1267
A60P1	1251-7469	3	1	CONN-POST TYPE .100-PIN-SPCG 110-CONT	28480	1251-7469
A60Q1	1853-0281	9	2	TRANSISTOR PNP 2N2907A SI TO-18 PD=400MW	04713	2N2907A
A60Q2	1854-0477	7	1	TRANSISTOR NPN 2N2222A SI TO-18 PD=500MW	04713	2N2222A
A60Q3	1853-0281	9		TRANSISTOR PNP 2N2907A SI TO-18 PD=400MW	04713	2N2907A

A60 Processor Component-Level Troubleshooting

Table A60-7. A60 Processor Replaceable Parts

Reference Designation	HP Part Number	C D	Qty	Description	Mfr Code	Mfr Part Number
A60R1	0757-0873	0	1	RESISTOR 1.62K 1% .5W F TC=0±100	28480	0757-0873
A60R2	0757-0280	3	2	RESISTOR 1K 1% .125W F TC=0±100	24546	C4-1/8-T0-1001-F
A60R3	0757-0442	9	10	RESISTOR 10K 1% .125W F TC=0±100	24546	C4-1/8-T0-1002-F
A60R4	0698-3157	3	2	RESISTOR 19.6K 1% .125W F TC=0±100	24546	C4-1/8-T0-1962-F
A60R5	0757-0442	9		RESISTOR 10K 1% .125W F TC=0±100	24546	C4-1/8-T0-1002-F
A60R6	0757-0290	5	1	RESISTOR 6.19K 1% .125W F TC=0±100	19701	MF4C1/8-T0-6191-F
A60R7	0698-3152	8	1	RESISTOR 3.48K 1% .125W F TC=0±100	24546	C4-1/8-T0-3481-F
A60R8	0698-3153	9	1	RESISTOR 3.83K 1% .125W F TC=0±100	24546	C4-1/8-T0-3831-F
A60R9	0698-3260	9	3	RESISTOR 464K 1% .125W F TC=0±100	28480	0698-3260
A60R10	0757-0280	3		RESISTOR 1K 1% .125W F TC=0±100	24546	C4-1/8-T0-1001-F
A60R11	0757-0442	9		RESISTOR 10K 1% .125W F TC=0±100	24546	C4-1/8-T0-1002-F
A60R12	0757-0442	9		RESISTOR 10K 1% .125W F TC=0±100	24546	C4-1/8-T0-1002-F
A60R13	0757-0442	9		RESISTOR 10K 1% .125W F TC=0±100	24546	C4-1/8-T0-1002-F
A60R14	0698-3260	9		RESISTOR 464K 1% .125W F TC=0±100	28480	0698-3260
A60R15	0698-3260	9		RESISTOR 464K 1% .125W F TC=0±100	28480	0698-3260
A60R16	0757-0401	0	1	RESISTOR 100 1% .125W F TC=0±100	24546	C4-1/8-T0-101-F
A60R17	0757-0438	3	3	RESISTOR 5.11K 1% .125W F TC=0±100	24546	C4-1/8-T0-5111-F
A60R18	0757-0438	3		RESISTOR 5.11K 1% .125W F TC=0±100	24546	C4-1/8-T0-5111-F
A60R19	0757-0416	7	2	RESISTOR 511 1% .125W F TC=0±100	24546	C4-1/8-T0-5111-F
A60R20	0757-0442	9		RESISTOR 10K 1% .125W F TC=0±100	24546	C4-1/8-T0-1002-F
A60R21	0757-0442	9		RESISTOR 10K 1% .125W F TC=0±100	24546	C4-1/8-T0-1002-F
A60R22				NOT ASSIGNED		
A60R23	0757-0442	9		RESISTOR 10K 1% .125W F TC=0±100	24546	C4-1/8-T0-1002-F
A60R24	0757-0442	9		RESISTOR 10K 1% .125W F TC=0±100	24546	C4-1/8-T0-1002-F
A60R25	0757-0442	9		RESISTOR 10K 1% .125W F TC=0±100	24546	C4-1/8-T0-1002-F
A60R26	0698-3155	1	2	RESISTOR 4.64K 1% .125W F TC=0±100	24546	C4-1/8-T0-4641-F
A60R27	0698-3155	1		RESISTOR 4.64K 1% .125W F TC=0±100	24546	C4-1/8-T0-4641-F
A60R28	0757-0416	7		RESISTOR 511 1% .125W F TC=0±100	24546	C4-1/8-T0-5111-F
A60R29	0757-0438	3		RESISTOR 5.11K 1% .125W F TC=0±100	24546	C4-1/8-T0-5111-F
A60R30	0698-3157	3		RESISTOR 19.6K 1% .125W F TC=0±100	24546	C4-1/8-T0-1962-F
A60TP1-TP26	0360-0535	0	26	TERMINAL TEST POINT PCB	00000	ORDER BY DESCRIPTION
A60U1	1826-0759	9	1	IC COMPARATOR GP QUAD 14-DIP-C PKG	04713	LM339J
A60U2	1810-0206	8	1	NETWORK-RES 8-SIP10.0K OHM X 7	01121	208A103
A60U3	1813-0196	1	1	XTAL-CLOCK-OSCILLATOR 14.7456-MHZ	28480	1813-0196
A60U4	1820-3449	8	1	IC-PARALLEL INTERFACE/TIMER/8MHZ/MC68000	28480	1820-3449
A60U5	1820-3172	4	1	IC FF CMOS/74HC J-K BAR POS-EDGE-TRIG	28480	1820-3172
A60U6	1820-3513	7	1	IC TRANSCEIVER TTL S INSTR-BUS IEEE-488	27014	BS75161AN
A60U7	1820-3431	8	1	IC TRANSCEIVER TTL S INSTR-BUS IEEE-488	27014	BS75160AN
A60U8	1820-3401	2	1	IC BFR TTL ALS OR QUAD 2-INP	28480	1820-3401
A60U9	1810-0276	2	2	NETWORK-RES 10-SIP1.5K OHM X 9	01121	210A152
A60U10	08340-80005	6	1	IO DECODER	28480	08340-80005
A60U11	1820-2548	6	1	IC GENERAL PURPOSE INTERFACE BUS ADAPTER	28480	1820-2548
A60U12	1810-0276	2		NETWORK-RES 10-SIP1.5K OHM X 9	01121	210A152
A60U13	1820-1112	8	1	IC FF TTL LS D-TYPE POS-EDGE-TRIG	01295	SN74LS74AN
A60U14	1820-1997	7	3	IC FF TTL LS D-TYPE POS-EDGE-TRIG PRL-IN	01295	SN74LS374N
A60U15	1810-0279	5	4	NETWORK-RES 10-SIP4.7K OHM X 9	01121	210A472
A60U16	1820-1997	7		IC FF TTL LS D-TYPE POS-EDGE-TRIG PRL-IN	01295	SN74LS374N
A60U17	1810-0279	5		NETWORK-RES 10-SIP4.7K OHM X 9	01121	210A472
A60U18	1820-2675	0	2	IC RCVR TTL LS BUS OCTL	01295	SN74LS646N
A60U19	1820-2675	0		IC RCVR TTL LS BUS OCTL	01295	SN74LS646N
A60U20	1820-1203	8	1	IC GATE TTL LS AND TPL 3-INP	01295	SN74LS11N
A60U21	1820-2102	8	1	IC LCH TTL LS D-TYPE OCTL	01295	SN74LS373N
A60U22	1820-1997	7		IC FF TTL LS D-TYPE POS-EDGE-TRIG PRL-IN	01295	SN74LS374N
A60U23	08340-80007	8	1	DECODER	28480	08340-80007
A60U24	1820-1851	2	1	IC ENCDR TTL LS	01295	SN74LS148N
A60U25	1820-2656	7	1	IC GATE TTL ALS NAND QUAD 2-INP	01295	SN74ALS00N
A60U26	1810-0279	5		NETWORK-RES 10-SIP4.7K OHM X 9	01121	210A472
A60U27	1820-4570	8	1	IC -MPU; CLK FREQ=8MHZ, INSTRUCTION	28480	1820-4570
A60U28	1820-1492	7	1	IC BFR TTL LS INV HEX 1-INP	01698	SN74LS368AN
A60U29	08340-80006	7	1	MEMORY DECODER	28480	08340-80006
A60U30	1810-0205	7	1	NETWORK-RES 8-SIP4.7K OHM X 7	01121	208A472
A60U31	1810-0279	5		NETWORK-RES 10-SIP4.7K OHM X 9	01121	210A472
A60U32	1818-4227	7	2	IC EPROM 2KX8	28480	1818-4227
A60U33	1818-4227	7		IC EPROM 2KX8	28480	1818-4227
A60U34-A60737	08340-60323	9	1	PROGRAMMED UVEPROM SERVICE KIT (Contains 4 UVEPROMS, 4 sockets, and instructions) UVEPROMS not separately replaceable	28480	08340-60323

A60 Processor Component-Level Troubleshooting

Table A60-7. A60 Processor Replaceable Parts

Reference Designation	HP Part Number	C D	Qty	Description	Mfr Code	Mfr Part Number
A60U38	1818-3183	2	2	IC CMOS 65536 (64K) STAT RAM 150-NS 3-S	28480	1818-3183
A60U39	1818-3183	2		IC CMOS 65536 (64K) STAT RAM 150-NS 3-S	28480	1818-3183
A60U40	1251-4787	2	1	SHUNT-DIP 8-POSITION	28480	1251-4787
A60VR1	1902-3107	9	1	DIODE-ZNR 5.76V 2% DO-35 PD=.4W	28480	1902-3107
A60X1	1200-0607	0	1	SOCKET-IC 16-CONT DIP DIP-SLDR	28480	1200-0607

Front Panel/Rear Panel Component-Level Service G

CONTENTS

A1 ALPHA DISPLAY

CIRCUIT DESCRIPTION	A1-1
Assembly Purpose	A1-1
Dot Matrix Display	A1-1
TROUBLESHOOTING	A1-3
How to Troubleshoot the Alpha Display	A1-3

A2 DISPLAY DRIVER

CIRCUIT DESCRIPTION	A2-1
Assembly Purpose	A2-1
Numeric Segment Drivers (Block A)	A2-1
Numeric Displays (Block B, C, D)	A2-2
Light Emitting Diode (LED) Annunciators (Block E)	A2-2
Level Shifters (Block F)	A2-2
Shift Register/Numeric Digit Driver (Block G)	A2-2
Control Data Latch (Block H)	A2-2
Alpha Column Drivers (Block I)	A2-3
TROUBLESHOOTING	A2-4
All Numeric Displays are Off	A2-4
One or More Numeric Segments are Always or Never On	A2-4
Neither the Segment Drivers nor the Digit Drivers are Faulty	A2-4
Led Annunciators (Block E)	A2-5
Level Shifters (Block F)	A2-5
How to Check the Shift Register/Numeric Digit Driver (Block G)	A2-5
How to Check the Control Data Latch (Block H)	A2-6
How to Check the Alpha Column Drivers (Block I)	A2-6
A62J1 Pin I/O	A2-7
A1 Alpha Display Component Location Diagram	A2-8
A2 Display Driver Component Location Diagram	A2-10
A1 Alpha Display and A2 Display Driver Schematic Diagram	A2-11
A1/A2 Replaceable Parts	A2-13

A3 DISPLAY PROCESSOR

CIRCUIT DESCRIPTION	A3-1
Assembly Purpose	A3-1
Preset Circuitry (Block A)	A3-1
Instrument Bus Interface (Block B)	A3-1
Display Supply (Block C)	A3-2
Display Processor (Block D)	A3-3
Annunciator Latch/Driver (Block E)	A3-3
DSA Connector (Block F)	A3-3
Alpha Display Shift Register (Block G)	A3-4
Power Supplies (Block H)	A3-4

CONTENTS (Cont'd)

TRUBLESHOOTING	A3-5
How to Check the Preset Circuitry (Block A)	A3-5
If all the Annunciators Stay on After [Instr Preset]	A3-5
If the Front Panel Enters Display Self Test Mode at Power On	A3-6
If the Display Remains Blank or has Incorrect Messages	A3-6
How to Troubleshoot the Display Supply (Block C)	A3-7
How to Troubleshoot the Display Processor Section (Block D)	A3-8
How to Troubleshoot the Annunciator Latch/Driver (Block E)	A3-9
If the Entry Display is Blank or if All Dots are On	A3-10
Signature Analysis	A3-10
DSA Using the Display Memory Routine	A3-11
A3 Display Processor Component Location Diagram	A3-14
A3 Display Processor Schematic Diagram	A3-15
A3 Display Processor Replaceable Parts	A3-17

A5 KEYBOARD AND A7 LOWER KEYBOARD

CIRCUIT DESCRIPTION	A5-1
Assembly Purpose	A5-1
Annunciators (Block A)	A5-1
Main Keyboard and Lower Keyboard (Block B)	A5-1
TRUBLESHOOTING	A5-2
If an Annunciator is not Working Properly	A5-2
If a Key is not Working Properly	A5-2
A5 Keyboard Component Location Diagram	A5-4
A7 Lower Keyboard, Component Location Diagram	A5-6
A5 Keyboard and A7 Lower Keyboard Schematic Diagram	A5-7
A5 Keyboard Replaceable Parts	A5-9
A7 Lower Keyboard Assembly	A5-11

A6 KEYBOARD INTERFACE

CIRCUIT DESCRIPTION	A6-1
Assembly Purpose	A6-1
Keyboard Encoder/Data Buffer (Block A)	A6-1
Key Up Timer (Debounce) (Block B)	A6-2
Key Down Timer (Block C)	A6-2
SRQ Buffer (Block I)	A6-3
Repeat Function Circuits (Block D)	A6-4
RPG Counters Data Buffers (Block G)	A6-4
RPG Count Window Timer (Block H)	A6-4
Annunciator Latches (Block E)	A6-5
Address Decoder (Block F)	A6-5
Power Switch and Standby LED	A6-5

CONTENTS (Cont'd)

TROUBLESHOOTING	A6-6
How to Check the Keyboard Encoder/Data Buffer (Block A)	A6-6
How to Troubleshoot L Stepup (Block A)	A6-7
How to Check the Key Up Timer (Block B)	A6-7
How to Check the Key Down Timer (Block C)	A6-8
How to Check the Repeat Function Circuits (Block D)	A6-9
How to Check the Annunciator Latches (Block E)	A6-10
How to Check the Address Decoder (Block F)	A6-11
How to Check the RPG Counters/Data Buffers (Block G)	A6-12
How to Check the RPG Count Window Timer (Block H)	A6-13
How to Check the Service Request Buffer (Block I)	A6-13
How to Check the Instrument Preset Buffer (Block J)	A6-13
A6 Keyboard Interface Signature Analysis	A6-14
A6 Keyboard Interface Component Location Diagram	A6-18
A6 Keyboard Interface Schematic Diagram	A6-19
A6 Keyboard Interface Replaceable Parts	A6-21

REAR PANEL COMPONENT-LEVEL INFORMATION

Rear Panel Replaceable Parts	G-3
------------------------------------	-----

A1 Alpha Display Circuit Description

ASSEMBLY PURPOSE

The A1 alpha display assembly provides the physical mounting for the seven 4-character dot matrix display elements. The assembly is mounted on the front panel bezel, and interfaces to the A2 display driver assembly via a multi-pin connector.

DOT MATRIX DISPLAY

An integrated 5X7 dot matrix display, consisting of seven, 4-character devices (for a total of 28 characters), displays alphanumeric information.

How the 4-Character Devices Work

Figure A1-1 illustrates one 4-character device. Each character is made up of 35 LEDs (5 columns, 7 rows each). For each character, the 5 LEDs in each row are common to a single row driver. For all 28 characters, the 7 LEDs in each column (1 through 5) are common to a single column driver (i.e. column 1 in all 28 characters is driven by the same column driver).

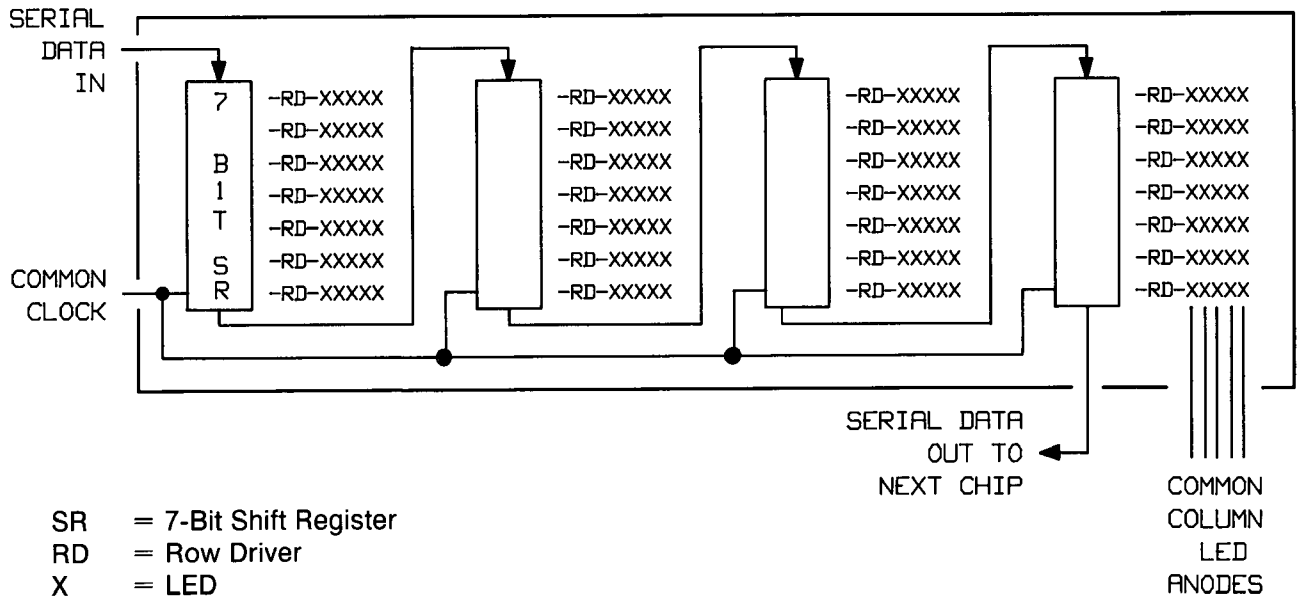

Figure A1-1. Alpha Display 4-Character Device

How the Microprocessor Displays Information

When something is to be displayed, the display processor reads the last character position from RAM and determines which column is required. It then looks up the bit pattern for the 7 LEDs in that column and outputs the 7 bits to the appropriate shift register. The shift register outputs the 7 bits to the displays and the LEDs light. Because the 5 LEDs in each row have a common row driver, if a bit for that particular row is a 1, the LED cathodes in that row are pulled low. The appropriate LED turns on, however, because that column line is pulled high. Then the display processor reads the next-to-last character and repeats the above sequence until all 196 bits (7 rows by 28 characters) are shifted into the displays. The sequence is repeated for each of the five columns at a rate of approximately 80 times per second (the LEDs light for approximately 2.5 ms), providing a flicker-free display.

Where the Alpha Display Shift Clock Comes From

The alpha display shift clock is generated and controlled on the A3 display processor assembly.

How the Alpha Display Dissipates Heat

Because the alpha displays dissipate considerable power, they require a substantial heat sink. For this reason, the display devices are soldered into the printed circuit board, and the board is attached directly to the anodized aluminum front panel bezel assembly with screws. On the printed circuit board, all pins to the devices have as much copper connected to them as possible to conduct the heat into the copper of the board and then into the bezel. Use heat sink compound between the alpha display printed circuit board and the bezel to ensure a low thermal resistance.



DO NOT use silicone based thermal compound. Silicone based oil migrates passed element sockets, switch contacts, or printed circuit board edge connectors, raising contact resistance, or electrically isolating the contacts. Silicone based thermal compounds disperse into the air, depositing themselves anywhere in the instrument. Heat increases the rate of dispersion.

A1 Alpha Display Component-Level Troubleshooting

HOW TO TROUBLESHOOT THE ALPHA DISPLAY

1. Turn the instrument off and remove the A1, A2 and A3 assemblies from the display casting.
2. Plug the A1 assembly directly into the A2 assembly, and connect the ribbon cable from the motherboard. Do not let the A1 alpha display short out against the A2 Display Driver. Turn the instrument on.
3. If the alpha display works correctly when removed from the casting, suspect a shorted anodized insulator. If so, clean the casting and the printed circuit board, checking for sharp protrusions or foreign particles. Install a new insulator using a non-silicone base thermal compound.
4. If some of the characters are working and some are not, either a signal trace is open or one of the integrated displays is faulty. On the display device that is not working, probe CS1 through CS5, ALPHA CLK, and DATA IN. If the signals appear at the device pins, replace the display. If the DATA IN signal does not appear at the display (pin 12), either the display you are checking or the previous display is at fault.

A2 Display Driver Circuit Description

ASSEMBLY PURPOSE

The A2 display driver assembly contains the 7-segment displays and the instrument annunciators, and it provides an interface with the A1 alpha display assembly.

NUMERIC SEGMENT DRIVERS (BLOCK A)

How the Segments are Arranged

Each numeric digit is a combination of seven segments and a decimal point. There are eight segment drivers common to all digits plus one digit driver for each of the 31 digits. The anodes of the same segment in each numeric digit are connected in parallel to a segment driver; the cathodes of all eight segments within a digit are connected in parallel to a digit driver.

How the Display Processor Displays Numbers

To display numbers in all display digits, the display processor starts at the first digit, clearing the segment driver latch and turning on the digit driver for that digit (block G). The display processor then determines the character to be displayed in the digit and sets the appropriate bits on the segment driver latch.

Once the latch bits are set, the appropriate segment drivers supply current through the segment and out the digit driver. The segment drivers are on for a few tenths of milliseconds, and are turned off at the end of this display time when the shift register/digit driver shifts to drive the second digit. The second digit LED segments do not turn on until the processor determines the character to be displayed and turns on the appropriate segment drivers.

This process is repeated for all 31 digits, and then the processor starts with the first digit again, at a rate of about 80 times per second (the displays light for approximately 2.5 ms).

The Segment Current Source

Two transistors and two resistors form a segment current source. When the segment driver latch input goes high, the base bias resistor provides base current to the first transistor, which turns on and conducts current from the display supply, through its emitter resistor. The current increases until the voltage drop across the resistor equals the V_{be} drop of the second transistor, which begins to conduct, removing some of the base drive current from the first transistor.

An equilibrium is reached, with the second transistor conducting just enough current to remove the excess base current supplied to the first transistor. This type of current source is fairly immune to display supply voltage variations.

When the segment driver latch output goes low, it sinks all the current provided by the base bias resistor away from the base of the first transistor, turning off the current source.

Each of the eight segment current sources provides approximately 37 mA to each particular segment.

NUMERIC DISPLAYS (BLOCKS B, C, D)

The numeric displays consist of two 15 digit and one 5 digit monolithic 7-segment displays (A matched set provides equal illumination). In the instrument, only 13 of the 15 digits are used in each of the larger displays.

LIGHT EMITTING DIODE (LED) ANNUNCIATORS (BLOCK E)

Each annunciator is connected in series with a current limiting resistor to +12 volts. The resistor values are selected to make the apparent brightness to the eye the same on all annunciators.

LEVEL SHIFTERS (BLOCK F)

To meet the input voltage requirements of the power shift registers, level shifters must be used to translate the TTL levels to that required by these ICs.

When the input to the clock level shifter (CLK) is high, current is supplied to the base of the transistor through biasing components, turning the device on. When the transistor turns on, it pulls one end of the collector resistor down to approximately $-5V$. When the input to the clock level shifter is low, the base of the transistor is allowed to be pulled down to $-5.2V$, turning the device off and allowing the internal pull ups of the power shift register to pull the output high.

SHIFT REGISTER/NUMERIC DIGIT DRIVER (BLOCK G)

The numeric digit drivers are power shift registers whose outputs are capable of sinking 250 mA. When the start line (LVL STRT, etc) is pulsed high, all outputs of the shift register go high. After the start pulse, the first low going clock pulse applied to the clock line causes the first output of the register to go low. Each successive pulse on the clock line shifts this low output to the next output line and the previous line goes high. The low output shifts through each output line and finally is shifted out of the shift register at which time all outputs are again high. The outputs of the power shift registers are each connected to all segment cathodes of one digit thus when the output goes low it turns on all of the segments in that digit whose segment drivers are activated. The power shift registers have non-standard logic levels for the clock and start inputs. The clock input low level is $-2.2V$ and has a pull up inside the device so it can be driven from an open collector transistor. The start input has a high level of $+0.5V$ and a low level of $-0.8V$.

CONTROL DATA LATCH (BLOCK H)

The control data latch is an open collector addressable latch. The address inputs and the data input are connected to the display processor I/O port P10 through P13. The clock line is connected to the LE signal so each LE cycle the latch will be updated with the current information contained on the I/O port lines. Outputs go to the numeric display start pulse level translators and to the alpha display column drivers.

ALPHA COLUMN DRIVERS (BLOCK I)

The alpha column drivers are formed by column driver transistors and biasing resistors. When it is time for the processor to turn on one of the alpha columns, the processor pulls one of the column control lines in the control data latch low, which pulls the base of one of the column driver transistors low. This turns on the transistor, which pulls the column line up to the display supply voltage level, controlling the A1 alpha display indicators.

A2 Display Driver Component-Level Troubleshooting

ALL NUMERIC DISPLAYS ARE OFF

NOTE: If you press [SHIFT] [CONT], the displays turn off.

If all of the segments of all numeric displays are off, first check the display supply. Troubleshoot the shift register/numeric digit driver (block G), level shifters (block F), and numeric segment drivers (block A).

How to Check the U9 Control Signals

1. Press [SHIFT] [FREE RUN] to run the front panel display diagnostics. Set up the oscilloscope for 50 μ s/Div.
2. Probe CLR (U9 pin 15) with the oscilloscope. You should find low-going TTL pulses which are 10 to 50 μ s wide. If this signal is low all the time then all numeric displays remain off. If CLR is not correct, troubleshoot the display processor (A3 block D) or replace A2U9.
3. Probe LE (U9 pin 14) with the oscilloscope. Set the oscilloscope to 1 μ s/Div. You should find low going TTL pulses which are 0.36 μ s wide with a period of 1.36 μ s. If this signal does not appear, troubleshoot the display processor (A3 block D).
4. Probe the remaining inputs to U9 (pins 1, 2, 3, and 13). If any of these lines do not have TTL activity, or have incorrect voltage levels, troubleshoot the display processor (A3 block D).

ONE OR MORE NUMERIC DISPLAY SEGMENTS IS ALWAYS OR NEVER ON

If one or more of the numeric display's segments is always on or is never on, the problem most likely lies with the segment current source, or a bad shift register.

How to Check a Segment's Current Source

1. With an oscilloscope, probe the appropriate U9 output for the affected segment. Set the oscilloscope to 0.5 ms/Div. You should find various patterns of 0.3 ms wide, high-going pulses that are limited in amplitude to approximately 3 to 3.5V.
2. If the signal at the output of U9 is approximately correct, and the segment is always **on**, either the transistor connected to the display supply is shorted, or a trace from the current sources to the numeric displays is open or shorted.
3. If the signal at the output of U9 is approximately correct, and the segment is always **off**, the transistor connected to the display supply is open, the current limiting transistor is shorted, or a trace from the current sources to the numeric displays is open or shorted.

NEITHER THE SEGMENT DRIVERS NOR THE DIGIT DRIVERS ARE FAULTY

If you have determined that neither the segment drivers (block A) nor the digit drivers (block G) are faulty, replace the numeric display set. Because this display set is matched for intensity, either replace the entire set or use a segment driver of the same intensity.

LED ANNUNCIATORS (BLOCK E)

One or More Annunciators is Incorrectly On or Off

1. If one or more annunciator is incorrectly on or off, verify that the appropriate input (J11 or J13) is approximately 0.2V if the associated annunciator should be on, and 6.5 to 9V if the annunciator should be off.
2. If one or several annunciators are off when they should be on, and the input(s) from J11 and/or J13 is/are correct, check the +12V at the annunciator(s)
3. If +12V is not at the annunciator, look for an open trace along the top edge of the board or troubleshoot the A3 assembly. If +12V is present, replace the annunciator.

Annunciators are All Off When They Should Be On

1. If all of the annunciators are off, check the +12V supply or troubleshoot the annunciator latch on the A3 assembly.

LEVEL SHIFTERS (BLOCK F)

1. With the oscilloscope, check TP3 (NUM CLK). Set the oscilloscope to 1 μ s/Div. You should see 3 μ s wide, high-going, 3V pulses. If not, troubleshoot the display processor (A3 block D).
2. If the NUM CLK signal is greater than 3.5V, check the signal at the base of Q6. You should find 3 μ s wide pulses that are 0.6 to 0.8 volts high. If there are no pulses at the base of Q6, VR4 is open. If the pulses at the base of Q6 are higher than 0.8V, the base of Q6 is open.
3. Probe CLK with the oscilloscope. You should find 3 μ s wide, low-going pulses that go between -3 volts and at least +1.8V. If CLK stays at -3V, Q6 is shorted. If CLK stays near 5V, Q6 is open, or R7 is open.
4. To check the STRT level shifter circuits, probe the appropriate signal (LVL START, F1 START, or F2 START) at the cathode of VR1, VR2 or VR3. You should find 3 μ s wide, high-going pulses with levels from 0.7V to approximately 4 volts. If no signal appears, troubleshoot the control data latch (block H).
5. If one of these signals is greater than 4 volts, probe the associated test point (TP4, TP5, or TP7). You should find approximately \pm 1.5V levels. If the signal at the test point stays at -1.5 V, the zener diode is probably open. If this signal never goes negative, the zener may be shorted. Also, an input to one of the numeric digit drivers may be shorted.

HOW TO CHECK THE SHIFT REGISTER/NUMERIC DIGIT DRIVER (BLOCK G)

1. Check for +5.2V at U4, U5, and U8 pin 9.
2. Check for approximately 4.4 to 4.6 volts at U4 or U5 pin 10 and U8 pin 10. If this voltage is not present, replace CR1 or CR2 as appropriate.
3. Check the CLK signal at pin 9 of U4, U5, or U8. You should find 3 μ s wide, low-going pulses that go between -3V and at least +1.8V. If these pulses are not present, troubleshoot the level shifters (block F).

4. Check the STRT signal of the suspected driver at pin 8 of U4, U5, or U8. You should find 3 μ s wide, high-going pulses that go between approximately +1.5V and -1.5V. If these pulses are not present, troubleshoot the level shifters (block F).
5. Using small clip leads, connect a 1 k Ω resistor between the scope probe and +5V. Set the oscilloscope to 0.1 ms/Div and check the digit driver outputs (U4, U5 or U8). You should see 400 μ s wide, low-going pulses that go between +5V and approximately +0.5V. If these pulses do not appear, or if the low level is above +0.8V, replace the driver.

HOW TO CHECK THE CONTROL DATA LATCH (BLOCK H)

1. With an oscilloscope, check the P10 through P13 signals (U3 pins 1, 2, 3, and 13). Set the oscilloscope 0.5 ms/Div. If you find TTL activity, proceed with step 3.
2. Check LE (U3 pin 14). Set the oscilloscope to 1 μ s/Div. You should find 0.4 μ s wide, low-going pulses, with a period of 1.4 μ s.
3. On the three STRT lines you should find 3 μ s wide, high-going pulses. If any of these signals are not present, replace U3.
4. Check the COL1 through COL5 signals (U3 pins 4, 5, 6, 7, and 11). Set the oscilloscope to 0.5 ms/Div. You should find signals that go between 0.5V and 4V. If not, replace U3.

HOW TO CHECK THE ALPHA COLUMN DRIVERS (BLOCK I)

1. With an oscilloscope, check CS1 through CS5 at the collector of Q1 through Q5. Set the oscilloscope to 0.5 ms/Div. You should find approximately 1 ms wide, high-going pulses of varying amplitudes (at least 2V). If these signals are present, but one or more alpha display column is not lighting, check for opens to the A1 assembly, or troubleshoot the A1 alpha display.
2. If CS1, CS2, CS3, CS4, or CS5 remain high, connect a 1 k Ω resistor between your probe and ground using small clip leads and check that signal again. If the signal now appears, there is probably an open trace between the transistor and the alpha display devices.
3. If the signal remains high after performing step 2, either the associated transistor is shorted, or the input to this block is low all the time. Check the appropriate COL1 through COL5 signal at U3. If the signal appears at this point, the drive transistor may be shorted. If no signal appears at U3, troubleshoot the control data latch (block H).
4. If CS1, CS2, CS3, CS4, or CS5 remain low, check the appropriate COL1 through COL5 signal at U3. If a signal appears at the output of U3 but the output of the associated driver transistor (Q1 through Q5) remains low, a trace is open, one of the resistors in U2 is open, or the drive transistor is open. If no signal appears at U3, troubleshoot the control data latch (block H).

Table A2-1. A62J1 Pin I/O

A62J1 Pin	Mnemonic	A62W1P1	A62W1P2	Levels
1 2	GND PLANE +12V	PIN 1 PIN 2	PIN 1 PIN 2	0V +12V
3 4	DB0 DB1	PIN 3 PIN 4	PIN 3 PIN 4	TTL TTL
5 6	DB2 DB3	PIN 5 PIN 6	PIN 5 PIN 6	TTL TTL
7 8	DB4 DB5	PIN 7 PIN 8	PIN 7 PIN 8	TTL TTL
9 10	DB6 DB7	PIN 9 PIN 10	PIN 9 PIN 10	TTL TTL
11 12	DB8 DB9	PIN 11 PIN 12	PIN 11 TTL	TTL
13 14	DB10 DB11	PIN 13 PIN 14	PIN 13 PIN 14	TTL TTL
15 16	DB12 DB13	PIN 15 PIN 16	PIN 15 PIN 16	TTL TTL
17 18	DB14 DB15	PIN 17 PIN 18	PIN 17 PIN 18	TTL TTL
19 20	LIPS LSBY	PIN 19 NOT USED	PIN 19 PIN 20	TTL (LOW TRUE) 0V TO +22V
21 22	GND PLANE HPUP	NOT USED NOT USED	PIN 21 NOT USED	0V TTL (HIGH TRUE)
23 24	ADR0 ADR1	PIN 23 PIN 24	PIN 23 PIN 24	TTL TTL
25 26	ADR2 ADR3	PIN 25 PIN 26	PIN 25 PIN 26	TTL TTL
27 28	ADR4 LSTEPUP	PIN 27 NOT USED	PIN 27 PIN 28	TTL TTL (LOW TRUE)
29 30	GND PLANE +22V	PIN 29 NOT USED	PIN 29 PIN 30	0V +22V
31 32	+5.2V +5.2V	PIN 31 PIN 32	PIN 31 PIN 32	+5.2V +5.2V
33 34	+5.2V +5.2V	PIN 33 PIN 34	PIN 33 PIN 34	+5.2V +5.2V
35 36	+5.2V +5.2V	PIN 35 PIN 36	PIN 35 PIN 36	+5.2V +5.2V
37 38	+5.2V GND PLANE	NOT USED NOT USED	PIN 37 PLIN 38	+5.2V 0V
39 40	GND PLANE GND PLANE	PIN 39 NOT USED	PIN 39 PIN 40	0V 0V
41 42	GND PLANE -5.2V	NOT USED PIN 42	PIN 41 PIN 42	0V -5.2V
43 44	LSTP LSPLD	NOT USED NOT USED	NOT USED PIN 44	TTL (LOW TRUE) TTL
45 46	LSRQ GND PLANE	NOT USED NOT USED	PIN 45 PIN 46	TTL (LOW TRUE) 0V
47 48	SI0B GND PLANE	NOT USED PIN 48	PIN 47 PIN 48	TTL (LOW TRUE) 0V
49 50	ISOA GND PLANE	PIN 49 PIN 50	NOT USED PIN 50	TTL (LOW TRUE) 0V

Note: Refer to A62 motherboard wiring list for signal source and destination information.

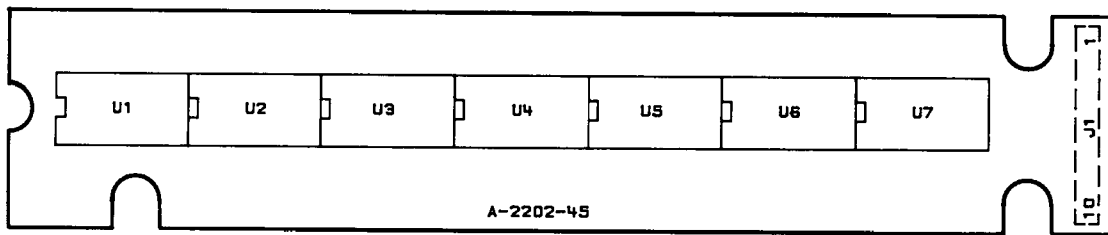

HP Part Number: 08340-60007

Figure A2-1. A1 Alpha Display Component Location Diagram

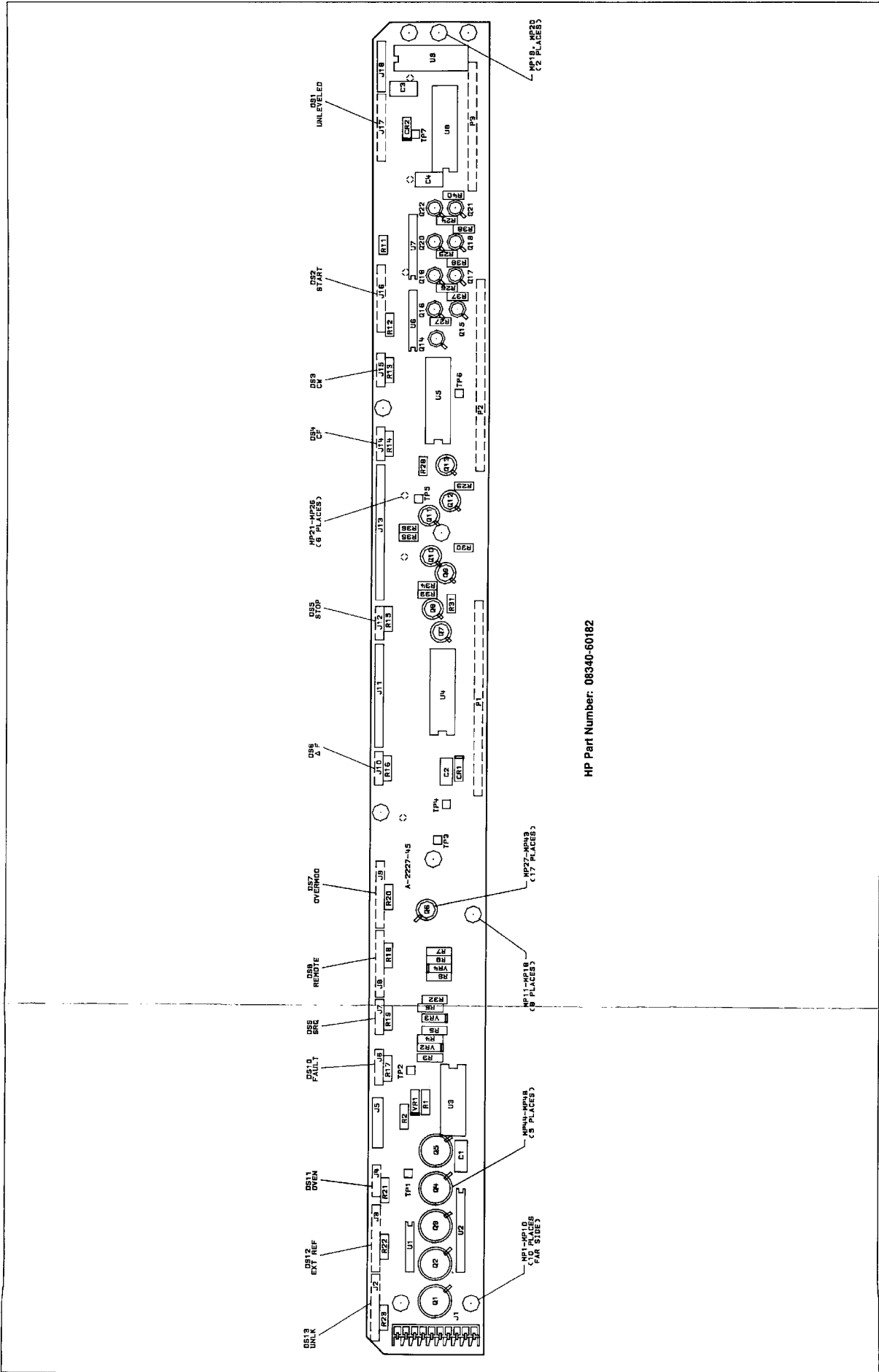

HP Part Number: 06340-60182

Figure A2-2. A2 Display Driver. Component Location Diagram
A2-10 Front/Rear Panel

- NOTES
1. ALL VOLTAGE LEVELS ARE WITH RESPECT TO THE COMMON GROUND POINT.
 2. ALL VOLTAGE LEVELS ARE WITH RESPECT TO THE COMMON GROUND POINT.
 3. ALL VOLTAGE LEVELS ARE WITH RESPECT TO THE COMMON GROUND POINT.
 4. ALL VOLTAGE LEVELS ARE WITH RESPECT TO THE COMMON GROUND POINT.

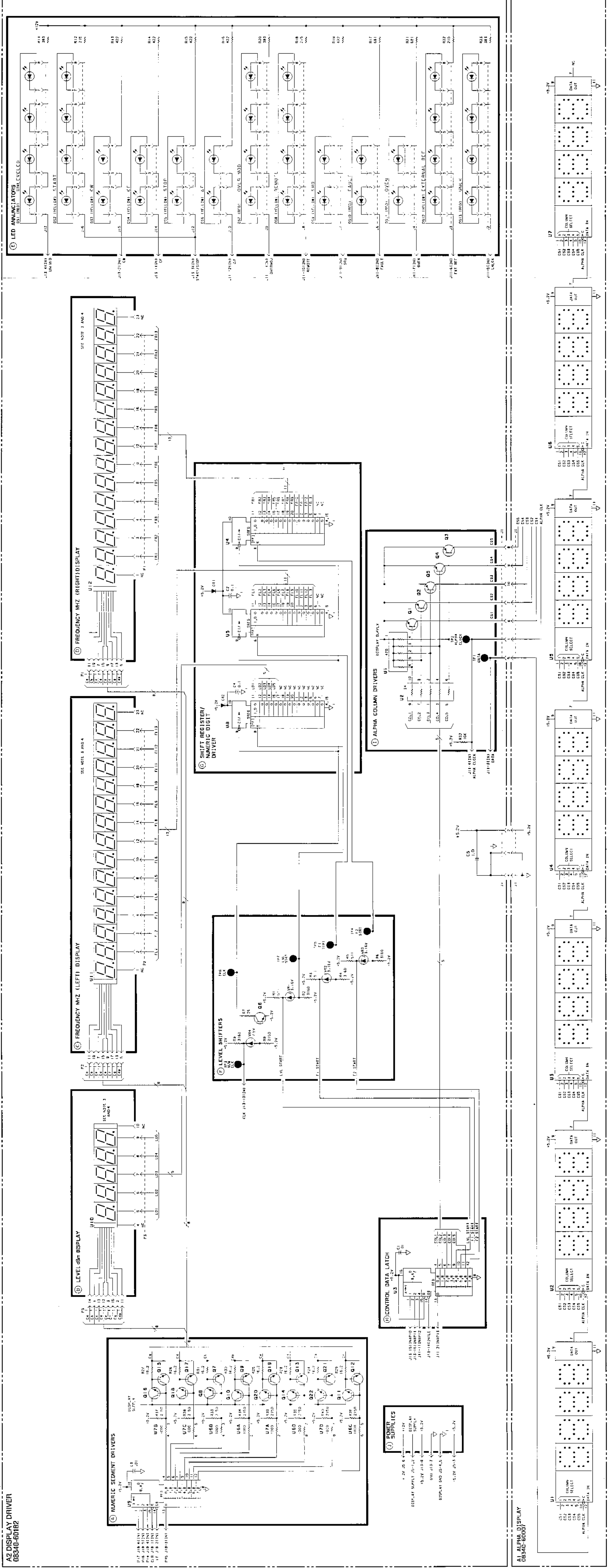

Figure A2-3. A1 Alpha Display and A2 Display Driver, Schematic Diagram Front/Rear Panel A2-I/A2-I2

A2 Display Driver Component-Level Troubleshooting

Table A2-2. A1/A2 Replaceable Parts

Reference Designation	HP Part Number	C D	Qty	Description	Mfr Code	Mfr Part Number
A1	08340-60007	6	1	ALPHA DISPLAY ASSEMBLY	28480	08340-60007
				NOTE: A1J1 must be cut to length before replacement.		
A1J1	1251-6798	9	1	CONNECTOR PC 36-CONT M	03206	65647-136
A1U1-7	1990-0919	0		DISPLAY ANNUNCIATOR SET MATCHED FOR LUMINOUS INTENSITY	28480	1990-0919
A1U1-7	1990-0553	8	7	DISPLAY ANNUNCIATOR .15-IN-HIGH	01542	QDSP-2049, CAT C
A2	08340-60182	8	1	DISPLAY DRIVER ASSEMBLY	28480	08340-60182
A2C1	0160-2055	9	2	CAPACITOR-FXD .01UF +80-20% 100VDC CER	28480	0160-2055
A2C2	0160-4084	8	2	CAPACITOR-FXD .1UF ±20% 50VDC CER	28480	0160-4084
A2C3	0160-2055	9		CAPACITOR-FXD .01UF +80-20% 100VDC CER	28480	0160-2055
A2C4	0160-4084	8		CAPACITOR-FXD .1UF ±20% 50VDC CER	28480	0160-4084
A2C5	0160-4535	4	1	CAPACITOR-FXD 1UF ±10% 50VDC CER	28480	0160-4535
A2CR1	1901-0033	2	2	DIODE-GEN PRP 180V 200MA DO-7	28480	1901-0033
A2CR2	1901-0033	2		DIODE-GEN PRP 180V 200MA DO-7	28480	1901-0033
A2DS1	1990-0699	3	3	L.E.D. (RED) 7 MCD	01542	1LM1-2350
A2DS2-6/8/9/12	1990-0887	1		L.E.D. SET MATCHED FOR LUMINOUS INTENSITY	28480	1990-0887
A2DS2	1990-0700	7	3	L.E.D. (YELLOW) 5 MCD	01542	1LM1-2450
A2DS3	1990-0697	1	5	L.E.D. (YELLOW) 2 MCD	01542	1LM1-2400
A2DS4	1990-0697	1		L.E.D. (YELLOW) 2 MCD	01542	1LM1-2400
A2DS5	1990-0697	1		L.E.D. (YELLOW) 2 MCD	01542	1LM1-2400
A2DS6	1990-0697	1		L.E.D. (YELLOW) 2 MCD	01542	1LM1-2400
A2DS7	1990-0699	3		L.E.D. (RED) 7 MCD	01542	1LM1-2350
A2DS8	1990-0700	7		L.E.D. (YELLOW) 5 MCD	01542	1LM1-2450
A2DS9	1990-0697	1		L.E.D. (YELLOW) 2 MCD	01542	1LM1-2400
A2DS10	1990-0696	0	2	LED-LIGHT BAR MODULE LUM-INT=3MCD	01542	1LM1-2300
A2DS11	1990-0696	0		LED-LIGHT BAR MODULE LUM-INT=3MCD	01542	1LM1-2300
A2DS12	1990-0700	7		L.E.D. (YELLOW) 5 MCD	01542	1LM1-2450
A2DS13	1990-0699	3		L.E.D. (RED) 7 MCD	01542	1LM1-2350
A2J1	1251-6063	1	1	CONNECTOR-PC 10 FEMALE IR	28480	1251-6063
A2J2	1200-0940	4	6	SOCKET-STRP 8-CONT DIP-SLDR	28480	1200-0940
A2J3	1200-0940	4		SOCKET-STRP 8-CONT DIP-SLDR	28480	1200-0940
A2J4	1200-0575	1	7	SOCKET-STRP 4-CONT DIP-SLDR	28480	1200-0575
A2J5	1251-6787	6	3	SOCKET-STRIP 6 CONTACT	28480	1251-6787
A2J6	1200-0575	1		SOCKET-STRP 4-CONT DIP-SLDR	28480	1200-0575
A2J7	1200-0575	1		SOCKET-STRP 4-CONT DIP-SLDR	28480	1200-0575
A2J8	1200-0940	4		SOCKET-STRP 8-CONT DIP-SLDR	28480	1200-0940
A2J9	1200-0940	4		SOCKET-STRP 8-CONT DIP-SLDR	28480	1200-0940
A2J10	1200-0575	1		SOCKET-STRP 4-CONT DIP-SLDR	28480	1200-0575
A2J11	1251-6787	6		SOCKET-STRIP 6 CONTACT	28480	1251-6787
A2J12	1200-0575	1		SOCKET-STRP 4-CONT DIP-SLDR	28480	1200-0575
A2J13	1251-6788	7	1	SOCKET-STRIP 16 CONTACT	28480	1251-6788
A2J14	1200-0575	1		SOCKET-STRP 4-CONT DIP-SLDR	28480	1200-0575
A2J15	1200-0575	1		SOCKET-STRP 4-CONT DIP-SLDR	28480	1200-0575
A2J16	1200-0940	4		SOCKET-STRP 8-CONT DIP-SLDR	28480	1200-0940
A2J17	1200-0940	4		SOCKET-STRP 8-CONT DIP-SLDR	28480	1200-0940
A2J18	1251-6787	6		SOCKET-STRIP 6 CONTACT	28480	1251-6787
A2MP1	08340-20060	7	10	STANDOFF PRIM	28480	08340-20060
A2MP2	08340-20060	7		STANDOFF PRIM	28480	08340-20060
A2MP3	08340-20060	7		STANDOFF PRIM	28480	08340-20060
A2MP4	08340-20060	7		STANDOFF PRIM	28480	08340-20060
A2MP5	08340-20060	7		STANDOFF PRIM	28480	08340-20060
A2MP6	08340-20060	7		STANDOFF PRIM	28480	08340-20060
A2MP7	08340-20060	7		STANDOFF PRIM	28480	08340-20060
A2MP8	08340-20060	7		STANDOFF PRIM	28480	08340-20060
A2MP9	08340-20060	7		STANDOFF PRIM	28480	08340-20060
A2MP10	08340-20060	7		STANDOFF PRIM	28480	08340-20060
A2MP11	08340-20061	8	8	STANDOFF-SEC	28480	08340-20061
A2MP12	08340-20061	8		STANDOFF-SEC	28480	08340-20061
A2MP13	08340-20061	8		STANDOFF-SEC	28480	08340-20061
A2MP14	08340-20061	8		STANDOFF-SEC	28480	08340-20061
A2MP15	08340-20061	8		STANDOFF-SEC	28480	08340-20061
A2MP16	08340-20061	8		STANDOFF-SEC	28480	08340-20061
A2MP17	08340-20061	8		STANDOFF-SEC	28480	08340-20061
A2MP18	08340-20061	8		STANDOFF-SEC	28480	08340-20061
A2MP19	08340-20063	0	2	STANDOFF-SHORT	28480	08340-20063
A2MP20	08340-20063	0		STANDOFF-SHORT	28480	08340-20063

A2 Display Driver Component-Level Troubleshooting

Table A2-2. A1/A2 Replaceable Parts

Reference Designation	HP Part Number	C D	Qty	Description	Mfr Code	Mfr Part Number	
A2MP21	08340-20066	3	6	SPACER POST	28480	08340-20066	
A2MP22	08340-20066	3		SPACER POST	28480	08340-20066	
A2MP23	08340-20066	3		SPACER POST	28480	08340-20066	
A2MP24	08340-20066	3		SPACER POST	28480	08340-20066	
A2MP25	08340-20066	3		SPACER POST	28480	08340-20066	
A2MP26	08340-20066	3		SPACER POST	28480	08340-20066	
A2MP27-43	1200-0172	4	17	INSULATOR-XSTR DAP-GL	28480	1200-0172	
A2MP44	1200-0173	5		5	INSULATOR-XSTR DAP-GL	28480	1200-0173
A2MP45	1200-0173	5			INSULATOR-XSTR DAP-GL	28480	1200-0173
A2MP46	1200-0173	5			INSULATOR-XSTR DAP-GL	28480	1200-0173
A2MP47	1200-0173	5			INSULATOR-XSTR DAP-GL	28480	1200-0173
A2MP48	1200-0173	5			INSULATOR-XSTR DAP-GL	28480	1200-0173
NOTE: A2P1 and 2 must be cut to length before replacement.							
A2P1	1200-0681	0	1	SOCKET-STRP 20-CONT DIP-SLDR	28480	1200-0681	
A2P2	1200-0681	0		SOCKET-STRP 20-CONT DIP-SLDR	28480	1200-0681	
A2P3	1251-6786	5		CONNECTOR-SINGLE CONTACT .02	28480	1251-6786	
A2Q1	1853-0442	4	5	TRANSISTOR PNP 2N3867 SI TO-5 PD=1W	04713	2N3867	
A2Q2	1853-0442	4		TRANSISTOR PNP 2N3867 SI TO-5 PD=1W	04713	2N3867	
A2Q3	1853-0442	4		TRANSISTOR PNP 2N3867 SI TO-5 PD=1W	04713	2N3867	
A2Q4	1853-0442	4		TRANSISTOR PNP 2N3867 SI TO-5 PD=1W	04713	2N3867	
A2Q5	1853-0442	4		TRANSISTOR PNP 2N3867 SI TO-5 PD=1W	04713	2N3867	
A2Q6	1854-0477	7	17	TRANSISTOR NPN 2N2222A SI TO-18 PD=500MW	04713	2N2222A	
A2Q7	1854-0477	7		TRANSISTOR NPN 2N2222A SI TO-18 PD=500MW	04713	2N2222A	
A2Q8	1854-0477	7		TRANSISTOR NPN 2N2222A SI TO-18 PD=500MW	04713	2N2222A	
A2Q9	1854-0477	7		TRANSISTOR NPN 2N2222A SI TO-18 PD=500MW	04713	2N2222A	
A2Q10	1854-0477	7		TRANSISTOR NPN 2N2222A SI TO-18 PD=500MW	04713	2N2222A	
A2Q11	1854-0477	7		TRANSISTOR NPN 2N2222A SI TO-18 PD=500MW	04713	2N2222A	
A2Q12	1854-0477	7		TRANSISTOR NPN 2N2222A SI TO-18 PD=500MW	04713	2N2222A	
A2Q13	1854-0477	7		TRANSISTOR NPN 2N2222A SI TO-18 PD=500MW	04713	2N2222A	
A2Q14	1854-0477	7		TRANSISTOR NPN 2N2222A SI TO-18 PD=500MW	04713	2N2222A	
A2Q15	1854-0477	7		TRANSISTOR NPN 2N2222A SI TO-18 PD=500MW	04713	2N2222A	
A2Q16	1854-0477	7	TRANSISTOR NPN 2N2222A SI TO-18 PD=500MW	04713	2N2222A		
A2Q17	1854-0477	7	TRANSISTOR NPN 2N2222A SI TO-18 PD=500MW	04713	2N2222A		
A2Q18	1854-0477	7	TRANSISTOR NPN 2N2222A SI TO-18 PD=500MW	04713	2N2222A		
A2Q19	1854-0477	7	TRANSISTOR NPN 2N2222A SI TO-18 PD=500MW	04713	2N2222A		
A2Q20	1854-0477	7	TRANSISTOR NPN 2N2222A SI TO-18 PD=500MW	04713	2N2222A		
A2Q21	1854-0477	7	TRANSISTOR NPN 2N2222A SI TO-18 PD=500MW	04713	2N2222A		
A2Q22	1854-0477	7	TRANSISTOR NPN 2N2222A SI TO-18 PD=500MW	04713	2N2222A		
A2R1	0757-0416	7	3	RESISTOR 511 1% .125W F TC=0±100	24546	C4-1/8-T0-511R-F	
A2R2	0757-0279	0		4	RESISTOR 3.16K 1% .125W F TC=0±100	24546	C4-1/8-T0-3161-F
A2R3	0757-0416	7			RESISTOR 511 1% .125W F TC=0±100	24546	C4-1/8-T0-511R-F
A2R4	0757-0279	0			RESISTOR 3.16K 1% .125W F TC=0±100	24546	C4-1/8-T0-3161-F
A2R5	0757-0416	7			RESISTOR 511 1% .125W F TC=0±100	24546	C4-1/8-T0-511R-F
A2R6	0757-0279	0	RESISTOR 3.16K 1% .125W F TC=0±100	24546	C4-1/8-T0-3161-F		
A2R7	0698-3132	4	1	RESISTOR 261 1% .125W F TC=0±100	24546	C4-1/8-T0-2610-F	
A2R8	0698-0084	9		1	RESISTOR 2.15K 1% .125W F TC=0±100	24546	C4-1/8-T0-2151-F
A2R9	0757-0279	0			RESISTOR 3.16K 1% .125W F TC=0±100	24546	C4-1/8-T0-3161-F
A2R10					NOT ASSIGNED		
A2R11	0698-3446	3			3	RESISTOR 383 1% .125W F TC=0±100	24546
A2R12	0698-3441	8	3	RESISTOR 215 1% .125W F TC=0±100	24546	C4-1/8-T0-215R-F	
A2R13	0698-3447	4		5	RESISTOR 422 1% .125W F TC=0±100	24546	C4-1/8-T0-422R-F
A2R14	0698-3447	4			RESISTOR 422 1% .125W F TC=0±100	24546	C4-1/8-T0-422R-F
A2R15	0698-3447	4			RESISTOR 422 1% .125W F TC=0±100	24546	C4-1/8-T0-422R-F
A2R16	0698-3447	4			RESISTOR 422 1% .125W F TC=0±100	24546	C4-1/8-T0-422R-F
A2R17	0757-0419	0	2	RESISTOR 681 1% .125W F TC=0±100	24546	C4-1/8-T0-681R-F	
A2R18	0698-3441	8		RESISTOR 215 1% .125W F TC=0±100	24546	C4-1/8-T0-215R-F	
A2R19	0698-3447	4		RESISTOR 422 1% .125W F TC=0±100	24546	C4-1/8-T0-422R-F	
A2R20	0698-3446	3		RESISTOR 383 1% .125W F TC=0±100	24546	C4-1/8-T0-383R-F	
A2R21	0757-0419	0		RESISTOR 681 1% .125W F TC=0±100	24546	C4-1/8-T0-681R-F	
A2R22	0698-3441	8		RESISTOR 215 1% .125W F TC=0±100	24546	C4-1/8-T0-215R-F	
A2R23	0698-3446	3		RESISTOR 383 1% .125W F TC=0±100	24546	C4-1/8-T0-383R-F	
A2R24	0698-7193	5		8	RESISTOR 16.2 1% .05W F TC=0±100	24546	C3-1/8-T0-16R2-F
A2R25	0698-7193	5	RESISTOR 16.2 1% .05W F TC=0±100		24546	C3-1/8-T0-16R2-F	
A2R26	0698-7193	5	RESISTOR 16.2 1% .05W F TC=0±100		24546	C3-1/8-T0-16R2-F	
A2R27	0698-7193	5	RESISTOR 16.2 1% .05W F TC=0±100		24546	C3-1/8-T0-16R2-F	
A2R28	0698-7193	5	RESISTOR 16.2 1% .05W F TC=0±100		24546	C3-1/8-T0-16R2-F	
A2R29	0698-7193	5	RESISTOR 16.2 1% .05W F TC=0±100	24546	C3-1/8-T0-16R2-F		
A2R30	0698-7193	5	RESISTOR 16.2 1% .05W F TC=0±100	24546	C3-1/8-T0-16R2-F		

A2 Display Driver Component-Level Troubleshooting

Table A2-2. A1/A2 Replaceable Parts

Reference Designation	HP Part Number	C D	Qty	Description	Mfr Code	Mfr Part Number
A2R31	0698-7193	5		RESISTOR 16.2 1% .05W F TC=0±100	24546	C3-1/8-TO-16R2-F
A2R32	0698-3274	5	1	RESISTOR 10K 1% .125W F TC=0±25	28480	0698-3274
A2R33	0698-7244	7	8	RESISTOR 2.15K 1% .05W F TC=0±100	24546	C3-1/8-TO-2151-F
A2R34	0698-7244	7		RESISTOR 2.15K 1% .05W F TC=0±100	24546	C3-1/8-TO-2151-F
A2R35	0698-7244	7		RESISTOR 2.15K 1% .05W F TC=0±100	24546	C3-1/8-TO-2151-F
A2R36	0698-7244	7		RESISTOR 2.15K 1% .05W F TC=0±100	24546	C3-1/8-TO-2151-F
A2R37	0698-7244	7		RESISTOR 2.15K 1% .05W F TC=0±100	24546	C3-1/8-TO-2151-F
A2R38	0698-7244	7		RESISTOR 2.15K 1% .05W F TC=0±100	24546	C3-1/8-TO-2151-F
A2R39	0698-7244	7		RESISTOR 2.15K 1% .05W F TC=0±100	24546	C3-1/8-TO-2151-F
A2R40	0698-7244	7		RESISTOR 2.15K 1% .05W F TC=0±100	24546	C3-1/8-TO-2151-F
A2TP1	0360-2050	8	7	TERMINAL TEST POINT PCB	28480	0360-2050
A2TP2	0360-2050	8		TERMINAL TEST POINT PCB	28480	0360-2050
A2TP3	0360-2050	8		TERMINAL TEST POINT PCB	28480	0360-2050
A2TP4	0360-2050	8		TERMINAL TEST POINT PCB	28480	0360-2050
A2TP5	0360-2050	8		TERMINAL TEST POINT PCB	28480	0360-2050
A2TP6	0360-2050	8		TERMINAL TEST POINT PCB	28480	0360-2050
A2TP7	0360-2050	8		TERMINAL TEST POINT PCB	28480	0360-2050
A2U1	1810-0364	9	1	NETWORK-RES 6-SIP470.0 OHM X	5	01121206A471
A2U2	1810-0340	1	1	NETWORK-RES 10-SIP24.0 OHM X	5	01121210B240
A2U3	1820-2266	5	1	IC DRVR TTL 18324 NE590F		
A2U4	1820-1226	5	3	IC SHF-RGTR TTL ASYNCHRO SERIAL-IN	28480	1820-1226
A2U5	1820-1226	5	3	IC SHF-RGTR TTL ASYNCHRO SERIAL-IN	28480	1820-1226
A2U6	1810-0374	1	2	NETWORK-RES 8-SIP1.0K OHM X	4	01121208B102
A2U7	1810-0374	1		NETWORK-RES 8-SIP1.0K OHM X	4	01121208B102
A2U8	1820-1226	5		IC SHF-RGTR TTL ASYNCHRO SERIAL-IN	28480	1820-1226
A2U9	1820-1729	3	1	IC LCH TTL LS COM CLEAR 8-BIT	01295	SN74LS259N
A2U10/11/12	08340-60017	3	3	DISPLAY SET MATCHED FOR LUMINOUS INTENSITY	28480	08340-60017
A2VR1	1902-3036	3	3	DIODE-ZNR 3.16V 5% DO-7 PD=.4W TC=-.064%	28480	1902-3036
A2VR2	1902-3036	3		DIODE-ZNR 3.16V 5% DO-7 PD=.4W TC=-.064%	28480	1902-3036
A2VR3	1902-3036	3		DIODE-ZNR 3.16V 5% DO-7 PD=.4W TC=-.064%	28480	1902-3036
A2VR4	1902-0064	1	1	DIODE-ZNR 7.5V 5% DO-35 PD=.4W TC=+.05%	28480	1902-0064

A3 Display Processor Circuit Description

ASSEMBLY PURPOSE

The A3 display processor assembly provides the communication link for interfacing the main instrument microprocessor to the instrument displays. The instrument microprocessor sends display data to the A3 display processor via the instrument data and address busses. The A3 display processor stores the data in internal RAM (random access memory), and processes the data into the necessary control signals to display the information. The display processor has 2K of internal ROM (read only memory) that contains the program for display control.

The A3 display processor assembly outputs control signals to the A2 display driver assembly for the power/frequency 7-segment displays, the entry display 5X7 dot matrix displays, and the instrument LED annunciators.

PRESET CIRCUITRY (BLOCK A)

The preset circuitry:

- Allows the instrument preset signal to clear the annunciator LEDs (all on) and to reset the display processor.
- Allows either the instrument preset signal or the display processor to clear the numeric display segment driver data latch (all off).

Low Instrument Preset Signal (LIPS) and Clear (CLR)

The LIPS signal comes into a schmitt trigger buffer, is inverted twice and appears at the output of the second schmitt trigger buffer with its polarity unchanged. This buffered LIPS signal directly resets the annunciator latches (block E), and the display processor (block D). This active low signal is combined with an active low signal from the display processor I/O port P25 (block D), and the result is inverted to produce the active low clear that is sent to the numeric segment drivers (A2, block A).

INSTRUMENT BUS INTERFACE (BLOCK B)

The instrument bus interface consists of a 3-to-8 line decoder, an eight-bit latch, and an RS flip-flop.

3-to-8 Decoder

The 3-to-8 decoder decodes the address information from the instrument address bus and the SIOA signal, and generates I/O strobe LEN 5 or LEN 7. LEN 5 latches annunciator control bits (block E) off the instrument data bus. LEN 7 is both the interrupt strobe to the display processor, and the clock to the eight-bit D-latch, which latches the data sent to the display processor via the instrument data bus.

Eight-Bit Latch

The eight-bit latch connects the two asynchronous buses. The outputs of this latch are connected to the display assembly's internal data/address bus. When the display processor is ready to accept the data stored in the input latch, the processor read line goes low, enabling the latch, which outputs onto the display data bus.

Service Request Latch

The service request latch consists of two NAND gates connected as a set/reset flip-flop. One input is connected to the input decoder. The other input is connected to the display processor read line, which is high until data from the input latch is read. In this state, the set/reset flip-flop output is high until an input changes.

When the instrument microprocessor sends an interrupt to the display, the interrupt line (LEN7) first goes low, and then goes high. When this line goes low, it forces one input of the request latch to go low, and its output to go low. The flip-flop is then stable in this state. Because the flip-flop output is connected to the display processor interrupt line, when it goes low, the processor starts an interrupt sequence.

During the interrupt service routine, the display processor sets the read line low, which is connected to an input of the request flip-flop, and to the eight-bit data bus latch. When this happens, the request flip-flop output goes high.

DISPLAY SUPPLY (BLOCK C)

The entry and numeric displays can require as much as 2 amps of current, but the average current required is much less. Current peaks or transients caused by strobing the displays can cause spurs on the instrument's RF output.

Constant Current Source

A constant current source connected to the instrument +5.2V supply provides a constant load for the instrument supplies. The output of this current source, along with a large amount of stored energy (output capacitors), is connected to the LED current source circuits. The current source provides slightly more than the average amount of current required by the LEDs, and the capacitors provide the additional current required during peak demands.

How the Current Source is Adjusted

The average current demand of the displays changes as more or less segments or characters are turned on. To keep the current source in regulation during both high and low average current demands, the current source is adjustable. The voltage is sensed at the energy storage capacitors through sense resistor R11, and as this voltage goes down, the voltage at the integrator output goes up. This causes an increase in the current to the display supply. The current source does not track the output voltage or respond to variations caused by strobing segments and columns, but responds only to slow variations in the average voltage at the display supply.

When the current source is supplying a large amount of current and the requirement goes down, it tries to continue supplying the large current. The voltage at the output rises until it cannot go any higher, and then the current source goes out of regulation. This causes a current transient on the main supply to the display. VR1 and R6 sink this excess current until the integrating feedback has time to reduce the average output current.

DISPLAY PROCESSOR (BLOCK D)

The display processor is an 8049 microprocessor that contains 128 bytes of random access memory (RAM), and 2K bytes of read only memory (ROM). The ROM contains all of the microcoded program that controls the display processor. This microcomputer contains an eight-bit down counter that uses a prescaled address latch enable (ALE) signal for its input clock. I/O consists of two 8-bit parallel ports that can be either input or output ports, and an 8-bit bi-directional processor bus.

The display uses the 128 bytes of RAM for internal registers, storage (characters displayed in the numeric and alpha displays), and a first-in-first-out register (FIFO).

How the Instrument Microprocessor Sends Information to the Display Processor

The instrument processor sends information to the display processor via the bidirectional instrument data bus, but the display processor cannot send data back to the instrument processor. The instrument processor outputs command or data information to the display interface latch. The display processor immediately takes the information in the interface latch and places it on the bottom of the FIFO. Commands and data contained on the FIFO are executed sequentially when the display processor is not refreshing the numeric and entry displays. This provides the minimum response time to interrupts from the instrument processor, and a flicker free display.

Clock Circuit

The oscillator circuit consists of a 10.92 MHz crystal connected to the display processor internal oscillator circuit. The internal oscillator circuitry provides a latch enable signal (LE) for the two control latches on the A2 assembly.

ANNUNCIATOR LATCH/DRIVER (BLOCK E)

When the annunciator strobe (LEN5) goes low and then high, the information on the instrument data bus is latched into the annunciator data latches, whose outputs drive the annunciator LEDs.

DSA CONNECTOR (BLOCK F)

Start, Stop, Clock and Ground are arranged in the same order as they appear on the HP 5005A signature analyzer pod. To enable the DSA function, short the ground (TP6) and DSA enable line (TP5) on the connector together, and **momentarily** force the LIPS line low by pressing instrument preset or by shorting LIPS to ground on the display.

ALPHA DISPLAY SHIFT REGISTER (BLOCK G)

How Information is Sent to the Alphanumeric Displays

The alpha displays (on the A1 assembly) require row information in serial form. The alpha display shift register parallel inputs are connected to the display data/address bus. When the display processor writes, the write line (block D) goes low and forces the parallel load line (LWRITE) low. At that time, the data on the data bus is loaded into the shift register. This information is then shifted serially to the alphanumeric integrated displays.

Alpha Display Clock Control

The alpha display clock synchronizes the transfer of serial data from the alpha display shift register into the serial shift registers contained within the alpha display integrated circuits.

POWER SUPPLIES (BLOCK H)

This circuitry filters out conducted transients caused by the display processor, TTL circuitry, and other display circuitry.

A3 Display Processor Component-Level Troubleshooting

HOW TO CHECK THE PRESET CIRCUITRY (BLOCK A)

1. Check LRESET (TP12) voltage. This should be a TTL high. Now press **[INSTR PRESET]** on the front panel; LRESET should go low. If LRESET is correct, proceed to step 3.
2. Probe LIPS at A3U9B pin 5. LIPS should also be high normally and should go low when you press **[INSTR PRESET]**.
3. Probe CLR at A3U9C pin 8 or A3P1-1. Set the oscilloscope to 0.2 ms/div and 1 V/Div. The CLR signal should be a continuous series of low pulses approximately 1 ms wide and 4 ms apart. Press **[INSTR PRESET]** and CLR should go low and remain low until you release the key. If both LRESET and CLR are correct, the preset circuitry is performing correctly.
4. Disconnect the display processor assembly (A3) from the display driver assembly (A2) and repeat step 3. If CLR is now correct, suspect a shorted trace or a shorted input to A2U9 on the A2 display driver assembly.
5. Check U9D pin 13 for pulses from the display processor (these are the same pulses as in step 3).

IF ALL THE ANNUNCIATORS STAY ON AFTER [INSTR PRESET]

If all annunciators remain lit at power up (similar to holding **[INSTR PRESET]** in), the instrument processor may not be running.

Check the Load Strobe

1. If the annunciators all stay on after **[INSTR PRESET]**, the load strobe (LEN5) from A3U10 may be bad (block B). Use direct I/O addressing to manually generate the strobe:

Press **[SHIFT] [GHz] [15] [Hz]**
[SHIFT] [MHz] [0] [Hz]
[SHIFT] [kHz]

2. With an oscilloscope, check LEN5 (A3U10 pin 10) while rotating the front panel knob. Set the oscilloscope to 0.2 us/div and 2V/div. Rotate the front panel knob to cause a series of writes to the annunciator's address. The oscilloscope should display low going pulses, approximately 300 ns wide. You can also use a logic probe to detect these pulses. If the pulses are present, troubleshoot the annunciator latch/driver (block E).
3. Probe SIOA (A3U10 pin 4) while rotating the front panel knob. You should again find 300 to 400 ns wide, low going pulses. If SIOA is pulsing, go to step 5.
4. Probe SIOA on the motherboard end of the ribbon cable. If SIOA is pulsing, replace the ribbon cable. If SIOA isn't pulsing, troubleshoot the A60 processor assembly.
5. Check each of the address bits (A0 through A4 A3U10 pins 5, 2, 3, 6, and 1) for bus activity while the instrument sweeps. The lack of activity on any one of these address bits indicates that a wire is probably open in the front panel ribbon cable.

IF THE FRONT PANEL ENTERS DISPLAY SELF TEST MODE AT POWER ON

1. If the Front Panel enters the display self test mode when power is turned on, and the main instrument processor is working, the display processor is probably not receiving interrupts. The interrupt strobe (LEN7) from A3U10 (block B) may be bad. To check this, use direct I/O addressing to manually generate the strobe:

Press **[SHIFT] [GHz] [15] [Hz]**
[SHIFT] [MHz] [2] [Hz]
[SHIFT] [kHz]

2. With an oscilloscope, check A3U10 pin 7 (LEN 7) while rotating the front panel knob. Set the oscilloscope to 0.2 us/div and 2V/div. Rotate the front panel knob to cause a series of writes to the display's address. The oscilloscope should display low going pulses, approximately 300 ns wide. You can also use a logic probe to detect pulses at this location. If the pulses are present, proceed to step 6.
3. Probe SIOA (A3U10 pin 4) while rotating the front panel knob. Again, you should find 300 to 400 ns wide, low going pulses. If SIOA is pulsing, proceed to step 5.
4. Probe SIOA on the Motherboard end of the ribbon cable. If SIOA is pulsing, replace the ribbon cable. If SIOA isn't pulsing, troubleshoot the A60 processor assembly.
5. Check each of the address bits (A0 through A4 A3U10 pins 5, 2, 3, 6, and 1) for bus activity while the instrument sweeps. The lack of activity on any one of these address bits indicates that a wire is probably open in the front panel ribbon cable.
6. Probe LIRQ (A3U3 pin 6). You should see low going pulses, between 10 and 25 us wide each time the display is addressed (LEN7 pulsed). This time varies due to differences in the response time of the display processor to interrupts from the instrument processor. If pulses are present at LIRQ, the service request latch is operating properly.
7. If LIRQ never goes low, check for low going pulses at A3U3 pin 4 each time you write to the display. If there are no pulses, replace A3U3.
8. Check the level of LREAD signal (A3U3 pin 5). LREAD is high normally, and goes low for 700 ns each time the display processor accepts an interrupt request.
9. If LREAD stays low, it prevents LIRQ from going low. check along the READ signal trace for a short.

IF THE DISPLAY REMAINS BLANK OR HAS INCORRECT MESSAGES

If the display remains BLANK or has garbled messages and numbers, one or more of the data bits may not be getting to the display processor. To check this, you can use digital signature analysis (DSA), or you can use the following manual procedure:

1. Set up the instrument to write to the display using direct I/O addressing:

Press **[SHIFT] [GHz] [15] [Hz]**
[SHIFT] [MHz] [2] [Hz].

2. Turn the instrument power switch to the STANDBY position.

3. Connect the following:

LRESET (TP12)	to	GROUND (TP10)
EA (TP8)	to	+12V (TP14)
READ (TP9)	to	GROUND (TP6)

4. Turn the instrument power switch to the ON position.
5. Write a 0 to the display interface latch:
Press **[SHIFT] [kHz] [0] [Hz]**.
6. Check that the interface latch outputs are low.
7. Write all 1's to the display interface latch:
Press **[2] [5] [5] [Hz]**.
8. Check each output for a high level.
9. If any of the outputs are not high or low when they should be, check the ribbon cable for opens. If there are no shorts in the cable, replace A3U6.

HOW TO TROUBLESHOOT THE DISPLAY SUPPLY (BLOCK C)

If the +5.2V power supply is correct, but the display supply is not, troubleshoot the display supply as follows:

If the Display Supply Voltage is <3V

If the display supply voltage is below approximately 3V, neither the numeric displays nor the entry display will light up with the proper intensity. If the display supply is below approximately 2V, all of the LEDs will be off.

1. Measure U11 pin 3. The voltage should be 4V. Measure U11 pin 5 (block C). The voltage should be 4.3V. If the voltage at these pins is incorrect, troubleshoot the 5V supply.
2. Measure the output of U11B (pin 7). Normally, this voltage is approximately 3.3V. If this output is approximately 0.1 to 0.2V, either Q1 or Q2 is probably open. Check the Q1 and Q2 base-emitter voltage to help determine which is at fault. If this output is near 5V, either CR2 is shorted, or U11 is bad.
3. Measure the voltage at U11B pin 5. This voltage should be approximately 4.3 volts (one diode drop below the supply). If it is greater than 4.3V, CR1 is shorted, R8 is open, or the input to the U11A (pin 5) is damaged.
4. Measure the voltage at U11A pin 3. It should be approximately 4V. If it is not, measure the voltage between U11A pin 2 and pin 3. If this voltage is not 0V, either R11 is open or U11 is bad. If this voltage is 0V, R12 or R13 is bad, causing the current source operating point to be incorrect.

If the Display Supply Voltage is $>4.2V$

- If the Display supply average voltage is greater than approximately 4.2V, the current source is not regulating.
- If the display supply voltage is above about 4.4V, VR1 is probably open.

Either of the above conditions causes excessive current fluctuations on the +5.2V supply that are conducted and radiated to sensitive circuits inside the instrument.

1. Measure U11 pin 3. The voltage should be 4V. Measure U11 pin 5 (block C). The voltage should be 4.3V. If the voltage at these pins is incorrect, troubleshoot the 5V supply.
2. Check the collector to emitter voltage of Q1. If this voltage is less than about 0.15V, Q1 is probably shorted or overdriven.
3. Check the collector to emitter voltage of Q2. This voltage should be approximately 3.6V. If it is less than about 0.08V, Q2 is probably shorted. If Vce is 0.1 to 3.5V, Q2 is over-driven by U11B.
4. To determine if U11A is operating correctly measure the voltage at U11A pin 3 and pin 1. These voltages should be approximately the same, and should be 3.9 to 4.0V. If the voltage at pin 3 is not near 4.0V, either R12, R13, or U11 is bad. If the voltage at pin 3 is about 4.0V but the output (pin 1) is not, a trace is shorted, U11A is bad, or the feedback path is open.
5. If the output of U11A is correct, measure the voltage at U11B pin 5. This voltage should be 4.2 to 4.3 volts. If it is near ground, CR1 is probably open.
6. If all measurements up to this point are correct, but the display supply is still saturated, replace U11.

HOW TO TROUBLESHOOT THE DISPLAY PROCESSOR SECTION (BLOCK D)

If you suspect the display processor is bad, first determine if all inputs to the processor are correct.

1. On an oscilloscope, verify the following voltages:

U1 pin 40	+5V
LRESET (U1 pin 4)	High
LIRQ (U1 pin 6)	High
EA (U1 pin 7)	Low
U1 pins 5 and 25	High

2. Check both sides of the crystal (Y1) with the oscilloscope set to 50 ns/Div. You should find a 10.92 MHz, 4V signal on both sides. If the signal is present, go to step 6.
3. Check both C1 and C2 to see if either is shorted.
4. If C1 and C2 are not shorted, replace Y1.
5. With an oscilloscope, check U1 pin 11 (LTE). Set the oscilloscope to 1 us/Div. This signal should have a period of approximately 1.4 us, and be low for 1 μ s. If LTE is present, go to step 7.

6. If LTE is not present, verify that the trace for LTE is not shorted. If LTE is not shorted, replace U1.
7. Check U3C pin 8 (LE) with the oscilloscope set to 1 us/div. You should find an inverted version of LTE. Press [INSTR PRESET]; LE should go high.

How to Check the Remaining Processor Outputs

If all other signals are correct, the remaining outputs from the processor are best checked using digital signal analysis (see SIGNATURE ANALYSIS, following HOW TO TROUBLESHOOT THE ANNUNCIATOR LATCH/DRIVER). You can also use the internal DSA routine below to exercise all of the processor outputs in a predictable manner and look at the outputs with an oscilloscope.

NOTE: If any of the following signals are not present, or are not the correct amplitude (at least 4V except for CLK), troubleshoot the block that the signal is connected to, or replace A3U1, as appropriate.

1. Connect TP5 (DSA EN) to TP4 (GND).
2. To start the DSA mode, turn the power switch to STANDBY and then to ON.
3. Set the oscilloscope to 1 us/Div and trigger off of the appropriate edge of the signal.
4. Check U1 pins 12 through 19 (D0 through D7). You should find low going TTL Level pulses that are 1 to 2 μ s wide.
5. Check U1 pins 27 through 34 (P10 through P17). You should find high going TTL pulses that are 3 to 4 μ s wide.
6. Check U1 pins 36 and 38 (P25 and P27). You should find high going TTL pulses that are 3 to 5 μ s wide.
7. Check U1 pin 37 (CLK). You should find high (1.6V) going pulses that are 3 to 4 μ s wide. This signal is clamped to 1.6V by the A2 assembly level shifters.
8. Check U1 pin 35 (START). Set the oscilloscope to 10 ms/Div. You should find a signal that is high for approximately 12 ms, and low for approximately 21 ms.

HOW TO TROUBLESHOOT THE ANNUNCIATOR LATCH/DRIVER (BLOCK E)

NOTE: If all the annunciators stay on after instrument preset but the rest of the display and the keyboard are correct, first troubleshoot the PRESET CIRCUITRY (block A) and then the INSTRUMENT BUS INTERFACE (block B).

NOTE: You can partially troubleshoot the annunciator latch/driver using DSA (see SIGNATURE ANALYSIS, following this procedure).

If One or More Annunciators is Incorrectly On or Off

1. If one or more annunciator is incorrectly on or off, verify that the appropriate outputs of U5 and U7 are low if the associated annunciator is on, and high if the annunciator is off.

2. Verify that the associated output of U4 or U8 is in the correct state (see NOTE below). The output of U4 or U8 should be approximately 0.2V if the annunciator is on, and 6.5 to 9V if the annunciator is off. If the outputs are correct, the annunciator latch/driver is operating correctly.

NOTE: Because the outputs of U4 and U8 are open collector outputs, an open trace, open series resistor, or open annunciator allows the output of U4 or U8 to stay low. If you suspect one of the above faults, attach a 1K ohm resistor between your probe and the +5 V supply. If the driver is working correctly, the levels will be 0.1 or 5V.

IF THE ENTRY DISPLAY IS BLANK OR IF ALL DOTS ARE ON

1. If the ENTRY display is blank, or if all dots are on, the alpha display shift register may not be working properly. To run the front panel display diagnostics, press **[SHIFT] [FREE RUN]**. Set an oscilloscope to display TTL levels at 2 μ s/Div.
2. With the oscilloscope, check P4-4 (ALPHA CLOCK, block G). You should find a series of seven 0.3 to 0.4 μ s wide, low going pulses. If these pulses are present, proceed to step 5.
3. Check U3D pin 11 for the pulses described in step 2. If there is no signal at U3D pin 11, check U3D pin 13 (LTE) for a continuous series of high going pulses 0.36 μ s wide with a period of 1.36 μ s. If no signal appears, troubleshoot the display processor (block D).
4. If LTE is correct at U3D pin 13, check U3D pin 12 (CLK CTL). You should find approximately 10 μ s wide, high going pulses that are used to gate on the clock pulses to the alpha displays. If no signal appears, troubleshoot the display processor (block D). If both LTE and CLK CTL are correct, replace U3.
5. Check U2 pin 1. You should find approximately 0.8 μ s wide, low going TTL pulses. If there are no pulses, troubleshoot the display processor (block D).
6. Check U2 pin 9 (DATA). You should find TTL activity in bursts of seven that correspond in time with the seven clock pulses at P4-4. If this activity is present, the alpha display shift register is working.

SIGNATURE ANALYSIS

The Digital Signal Analysis Options

Option 1 – Freerun DSA

You can force the display processor to repetitively count through its entire address space, and use a signature analyzer to determine if the correct signatures appear on D0 through D7, A8 through A10, and +5VF.

Option 2 – DSA Using the Display Memory Routine

You can enable the DSA mode to use the DSA routine in the display processor memory, and use a signature analyzer to determine if the correct signatures appear on D0 through D7, A8 through A10, the parallel I/O ports, and many other signal lines. This routine does not check the annunciator latches or drivers, the instrument bus interface latches, or any of the signals on the display driver assembly that have non-TTL levels.

Freerun DSA

When you select the freerun DSA mode, you force the display processor to do all instruction fetches from external memory. Because there is no external memory, and because D0 through D7 are pulled up, the front panel processor fetches FF hexadecimal instruction operating codes. After executing this instruction, the display processor increments its program counter and does an instruction fetch from the next location. In this way, the display processor repetitively counts through its entire memory space.

- To enable the freerun DSA mode, connect TP8 (EA) to TP7 (+5.2V).
- Connect the signature analyzer as follows:

START and STOP	U1 pin 23
Trigger	Falling edge
CLOCK	U3 pin 8
Trigger	Leading edge
- Check the signatures listed below:

Mnemonic	J1 Pin #	Signature
D0 D1	11 10	H62U C21A
D2 D3	9 8	HA07 H0AA
D4 D5	7 6	P030 4442
D6 D7	5 4	4U2A 0772
A8 A9	1 2	9635 1734
A10 +5.2VF	3 17	8P54 7A70

DSA USING THE DISPLAY MEMORY ROUTINE

- Connect TP5 (DSA EN) to TP6 (GND)

2. Connect the signature analyzer as follows:

START TP1
 Trigger Falling edge
 STOP TP2
 Trigger Leading edge
 CLOCK TP3
 Trigger Rising edge
 GND TP4

Under these conditions, the +5.2V signature should be H9U2, indicating that all processor instructions are being executed correctly, the ROM checksum is correct, and that the internal RAM is good.

3. Change the signature analyzer as follows:

START trigger Leading edge
 STOP trigger Falling edge

4. Check the signatures listed below:

Mnemonic	U1 Pin #	Signature
D0 D1	12 13	CPAC 20U1
D2 D3	14 15	5P21 8F24
D4 D5	16 17	FP86 023P
D6 D7	18 19	185F H576
P10 P11	27 28	C606 06F6
P12 P13	29 30	5868 39C4
P14 P15	31 32	H2A6 5FC3

Mnemonic	U3D Pin #	Signature
ALPHA CLOCK	11	F81C

Mnemonic	U9C Pin #	Signature
CLR	11 8	7551 CH4A

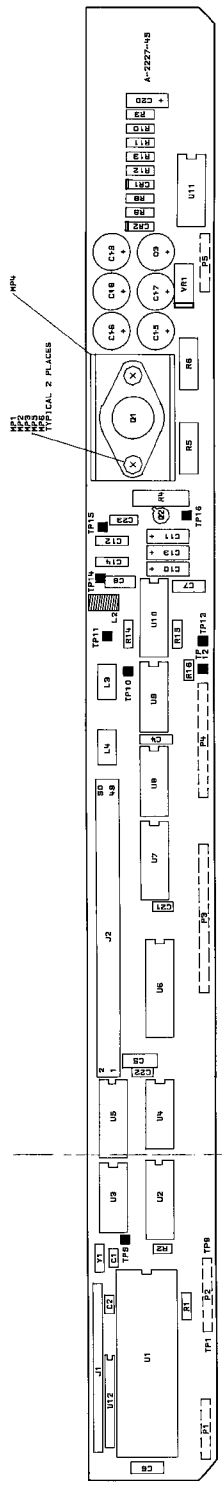

HP part Number: 06340-60008

Figure A3-1. A3 Display Processor: Component Location Diagram
A3-14 Front/Rear Panel

**A3 DISPLAY PROCESSOR
08340-60008**

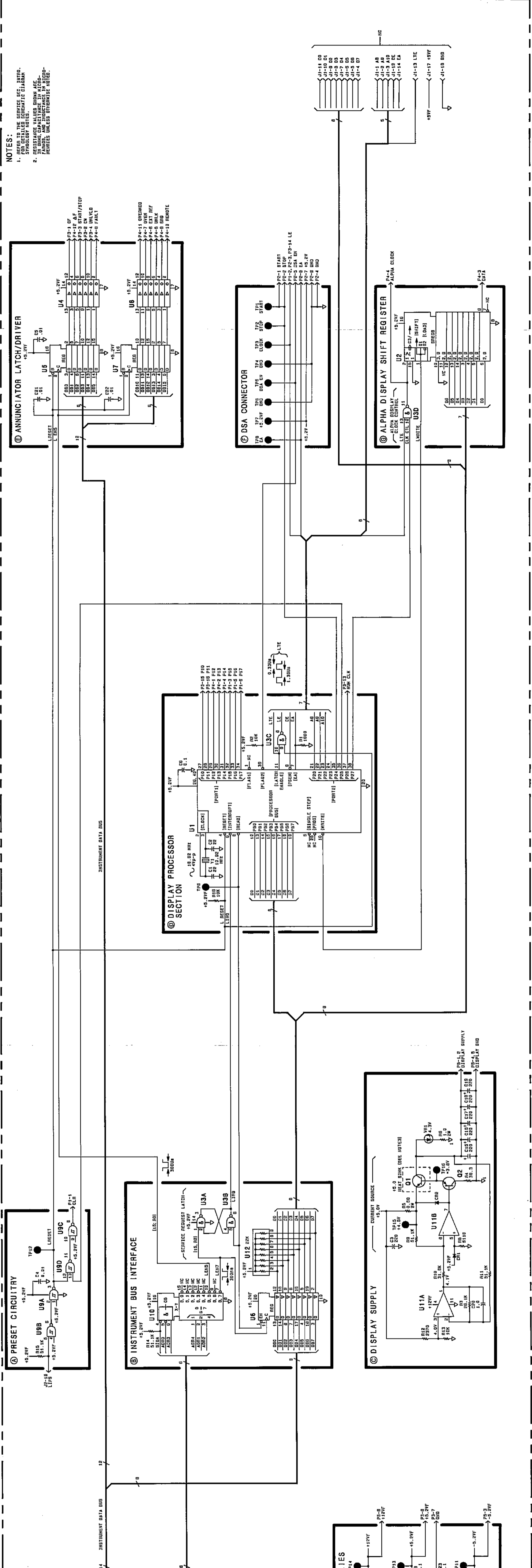

NOTES:
 1. REFER TO THE SERVICE SEC. INTRO. FOR THE LOCATION OF THE SCHEMATIC DIAGRAM.
 2. RESISTANCE VALUES SHOWN ARE THE OHMS CAPACITANCE IN MICRO-FARMS, AND DIMENSIONS IN INCHES, UNLESS OTHERWISE NOTED.

Figure A3-2. A3 Display Processor, Schematic Diagram
 Front/Rear Panel A3-15/A3-16

A3 Display Processor Component-Level Troubleshooting

Table A3-1. A3 Display Processor Replaceable Parts

Reference Designation	HP Part Number	C D	Qty	Description	Mfr Code	Mfr Part Number
A3	08340-60008	7	1	DISPLAY PROCESSOR ASSEMBLY	28480	08340-60008
A3C1	0160-3875	3	2	CAPACITOR-FXD 22PF ± 5% 200VDC CER 0 ± 30	28480	0160-3875
A3C2	0160-3875	3	2	CAPACITOR-FXD 22PF ± 5% 200VDC CER 0 ± 30	28480	0160-3875
A3C3	0180-0552	9	1	CAPACITOR-FXD 220UF ± 20% 10VDC TA	28480	0180-0552
A3C4	0160-2055	9	3	CAPACITOR-FXD .01UF + 80-20% 100VDC CER	28480	0160-2055
A3C5	0160-2055	9	3	CAPACITOR-FXD .01UF + 80-20% 100VDC CER	28480	0160-2055
A3C6	0160-4841	5	1	CAPACITOR-FXD .1UF + 80 - 20% 50VDC CER	28480	0160-4841
A3C7	0160-2055	9	1	CAPACITOR-FXD .01UF + 80-20% 100VDC CER	28480	0160-2055
A3C8	0160-4084	8	4	CAPACITOR-FXD .1UF ± 20% 50VDC CER	28480	0160-4084
A3C9				NOT ASSIGNED		
A3C10	0180-0228	6	2	CAPACITOR-FXD 22UF ± 10% 15VDC TA	56289	150D226X9015B2
A3C11	0180-0116	1	1	CAPACITOR-FXD 6.8UF ± 10% 35VDC TA	56289	150D685X9035B2
A3C12	0160-4084	8	1	CAPACITOR-FXD .1UF ± 20% 50VDC CER	28480	0160-4084
A3C13	0180-0228	6	1	CAPACITOR-FXD 22UF ± 10% 15VDC TA	56289	150D226X9015B2
A3C14	0160-4084	8	1	CAPACITOR-FXD .1UF ± 20% 50VDC CER	28480	0160-4084
A3C15	0180-3240	8	5	CAPACITOR-AL 220 UF 10VDC	28480	0180-3240
A3C16	0180-3240	8	1	CAPACITOR-AL 220 UF 10VDC	28480	0180-3240
A3C17	0180-3240	8	1	CAPACITOR-AL 220 UF 10VDC	28480	0180-3240
A3C18	0180-3240	8	1	CAPACITOR-AL 220 UF 10VDC	28480	0180-3240
A3C19	0180-3240	8	1	CAPACITOR-AL 220 UF 10VDC	28480	0180-3240
A3C20	0180-0291	3	1	CAPACITOR-FXD 1UF ± 10% 35VDC TA	56289	150D105X9035A2
A3C21	0160-3879	7	2	CAPACITOR-FXD .01UF ± 20% 100VDC CER	28480	0160-3879
A3C22	0160-3879	7	2	CAPACITOR-FXD .01UF ± 20% 100VDC CER	28480	0160-3879
A3C23	0160-4084	8	1	CAPACITOR-FXD .1UF ± 20% 50VDC CER	28480	0160-4084
A3CR1	1901-0033	2	2	DIODE-GEN PRP 180V 200MA DO-7	28480	1901-0033
A3CR2	1901-0033	2	2	DIODE-GEN PRP 180V 200MA DO-7	28480	1901-0033
A3J1	1251-6787	6	1	SOCKET STRIP-6 CONTACT	28480	1251-6787
A3J2	1251-5746	5	1	CONNECTOR 50-PIN M POST TYPE	28480	1251-5746
A3L1				NOT ASSIGNED		
A3L2	08340-80001	2	1	COIL-TOROID	28480	08340-80001
A3L3	9100-1788	6	2	CHOKE-WIDE BAND ZMAX=680 OHM½ 180 MHZ 02114	VK200	20/48
A3L4	9100-1788	6	2	CHOKE-WIDE BAND ZMAX=680 OHM½ 180 MHZ 02114	VK200	20/48
A3MP1	0340-1143	6	1	INSULATOR-XSTR ALUMINUM	28480	0340-1143
A3MP2	0590-0526	6	1	INSERT-NB 4-40	28480	0590-0526
A3MP3				NOT ASSIGNED		
A3MP4	1205-0085	8	1	HEAT SINK TO-66-CS	28480	1205-0085
A3MP5	2200-0105	4	2	SCREW-MACH 4-40 .312-IN-LG PAN-HD-POZI	00000	ORDER BY DESCRIPTION
A3MP6	2200-0105	4	2	SCREW-MACH 4-40 .312-IN-LG PAN-HD-POZI	00000	ORDER BY DESCRIPTION
				NOTE: A3P1-5 must be cut to length before replacement.		
A3P1	1251-6798	9	5	CONNECTOR-PC 36 MALE IR	28480	1251-6798
A3P2	1251-6798	9	5	CONNECTOR-PC 36 MALE IR	28480	1251-6798
A3P3	1251-6798	9	5	CONNECTOR-PC 36 MALE IR	28480	1251-6798
A3P4	1251-6798	9	5	CONNECTOR-PC 36 MALE IR	28480	1251-6798
A3P5	1251-6798	9	5	CONNECTOR-PC 36 MALE IR	28480	1251-6798
A3Q1	1853-0413	9	1	TRANSISTOR PNP 2N6049 SI TO-66 PD=75W	28480	1853-0413
A3Q2	1853-0281	9	1	TRANSISTOR PNP 2N2907A SI TO-18 PD=400MW	04713	2N2907A
A3R1	0757-0280	3	1	RESISTOR 1K 1% .125W F TC=0 ± 100	24546	C4-1/8-T0-1001-F
A3R2	0698-7260	7	2	RESISTOR 10K 1% .05W F TC=0 ± 100	24546	C3-1/8-T0-1002-F
A3R3	0698-3159	5	1	RESISTOR 26.1K 1% .125W F TC=0 ± 100	24546	C4-1/8-T0-2612-F
A3R4	0698-3396	2	1	RESISTOR 38.3 1% .5W F TC=0 ± 100	28480	0698-3396
A3R5	0811-1553	1	1	RESISTOR .68 5% 2W PW TC=0 ± 800	75042	BWH2-11/16-J
A3R6	0811-1666	7	1	RESISTOR 1 5% 2W PW TC=0 ± 800	75042	BWH2-1R0-J
A3R7				NOT ASSIGNED		
A3R8	0757-0438	3	1	RESISTOR 5.11K 1% .125W F TC=0 ± 100	24546	C4-1/8-T0-5111-F
A3R9	0757-0458	7	4	RESISTOR 51.1K 1% .125W F TC=0 ± 100	24546	C4-1/8-T0-5112-F
A3R10	0698-3160	8	1	RESISTOR 31.6K 1% .125W F TC=0 ± 100	24546	C4-1/8-T0-3162-F
A3R11	0757-0458	7	1	RESISTOR 51.1K 1% .125W F TC=0 ± 100	24546	C4-1/8-T0-5112-F
A3R12	0698-3150	6	1	RESISTOR 2.37K 1% .125W F TC=0 ± 100	24546	C4-1/8-T0-2371-F
A3R13	0757-0442	9	1	RESISTOR 10K 1% .125W F TC=0 ± 100	24546	C4-1/8-T0-1002-F
A3R14	0757-0458	7	1	RESISTOR 51.1K 1% .125W F TC=0 ± 100	24546	C4-1/8-T0-5112-F
A3R15	0757-0458	7	1	RESISTOR 51.1K 1% .125W F TC=0 ± 100	24546	C4-1/8-T0-5112-F
A3R16	0698-7260	7	1	RESISTOR 10K 1% .05W F TC=0 ± 100	24546	C3-1/8-T0-1002-F
A3TP1-8				NOT ASSIGNED		
A3TP9	0360-2050	8	8	TERMINAL TEST POINT, PCB	28480	0360-2050
A3TP10	0360-2050	8	8	TERMINAL TEST POINT, PCB	28480	0360-2050
A3TP11	0360-2050	8	8	TERMINAL TEST POINT, PCB	28480	0360-2050
A3TP12	0360-2050	8	8	TERMINAL TEST POINT, PCB	28480	0360-2050

A3 Display Processor Component-Level Troubleshooting

Table A3-1. A3 Display Processor Replaceable Parts

Reference Designation	HP Part Number	C D	Qty	Description	Mfr Code	Mfr Part Number
A3TP13	0360-2050	8		TERMINAL TEST POINT, PCB	28480	0360-2050
A3TP14	0360-2050	8		TERMINAL TEST POINT, PCB	28480	0360-2050
A3TP15	0360-2050	8		TERMINAL TEST POINT, PCB	28480	0360-2050
A3TP16	0360-2050	8		TERMINAL TEST POINT, PCB	28480	0360-2050
A3U1	1820-2865	0	1	IC-8-BIT MICROCOMPUTER; 11MHZ OPERATION	28480	1820-2865
A3U2	1820-1975	1	1	IC SHF-RGTR TTL LS NEG-EDGE-TRIG PRL-IN	01295	SN74LS165N
A3U3	1820-1287	8	1	IC BFR TTL LS NAND QUAD 2-INP	01295	SN74LS37N
A3U4	1820-0668	7	2	IC BFR TTL NON-INV HEX 1-INP	01295	SN7407N
A3U5	1820-1196	8	2	IC FF TTL LS D-TYPE POS-EDGE-TRIG COM	01295	SN74LS174N
A3U6	1820-1997	7	1	IC FF TTL LS D-TYPE POS-EDGE-TRIG PRL-IN	01295	SN74LS374N
A3U7	1820-1196	8		IC FF TTL LS D-TYPE POS-EDGE-TRIG COM	01295	SN74LS174N
A3U8	1820-0668	7		IC BFR TTL NON-INV HEX 1-INP	01295	SN7407N
A3U9	1820-1425	6	1	IC SCHMITT-TRIG TTL LS NAND QUAD 2-INP	01295	SN74LS132N
A3U10	1820-1216	3	1	IC DCDR TTL LS 3-TO-8-LINE 3-INP	01295	SN74LS138N
A3U11	1826-0161	7	1	IC OP AMP GP QUAD 14-DIP-P PKG	04713	MLM324P
A3U12	1810-0398	9	1	NETWORK-RES 10-SIP22.0K OHM X 9	11236	750-101-R22K
A3VR1	1902-1359	9	1	DIODE-ZNR 4.3V 2% PD=5W IR=10UA	28480	1902-1359
A3Y1	0410-1295	8	1	CRYSTAL-10.92 MHZ	28480	0410-1295

A5 Keyboard and A7 Lower Keyboard Circuit Description

ASSEMBLY PURPOSE

The A5 keyboard and the A7 lower keyboard assemblies provide the mechanical mounting for all instrument key assemblies. The key annunciators are also located on these assemblies. The keyboard assemblies communicate with the instrument microprocessor via the A6 keyboard interface assembly.

Because both the A5 keyboard assembly and the A7 lower keyboard assembly operate the same way, they are covered together in the following circuit description.

ANNUNCIATORS (BLOCK A)

Annunciator LEDs are controlled from the keyboard interface assembly. Latches ground the cathode, allowing current to flow from the +5.2V supply.

MAIN KEYBOARD AND LOWER KEYBOARD (BLOCK B)

The two keyboards contain a total of 58 keys that have a multi-finger contact structure. Each key shorts one column line and one row line to digital ground. When you press a key, the column and row signals are encoded by the keyboard interface. There is no general pattern followed for encoding columns and rows.

A5 Keyboard and A7 Lower Keyboard Component-Level Troubleshooting

IF AN ANNUNCIATOR IS NOT WORKING PROPERLY

1. If one of the front panel LEDs stays on all the time, troubleshoot the annunciator latches (A6, block E).
2. If one of the front panel LEDs never comes on, even when you press [INSTR PRESET], the cause is probably a bad LED.

To determine if the output of a latch is correct, check the output of A6U6, A6U7, A6U16, or A6U17, and press and hold [INSTR PRESET]. The voltage should be approximately 0.4V at all outputs.

If the voltage is correct, replace the appropriate LED. If not, troubleshoot the annunciator latches (A6, block E).

IF A KEY IS NOT WORKING PROPERLY

1. Determine the ROW number and the COLUMN number of the key that is not working correctly. Check the appropriate ROW and then the appropriate COLUMN at A6U1 or A6U10. Each signal should go low (0V) when the key is pressed.
2. If the row or column signal stays high, check for an open connector between the A5 or A7 keyboard and the A6 keyboard interface assembly. If there is no open trace or connector, replace the key.
3. If the row or column signal stays low, measure the resistance of this signal line to ground.
 - If the resistance is 1Ω or less, either the signal trace is shorted to ground, or the key is broken and is shorting the trace to ground.
 - If the resistance is greater than 1Ω , the associated input to A6U1 or A6U10 is probably shorted. Replace A6U1 or A6U10, as required.

A5 Keyboard and A7 Lower Keyboard Component-Level Troubleshooting

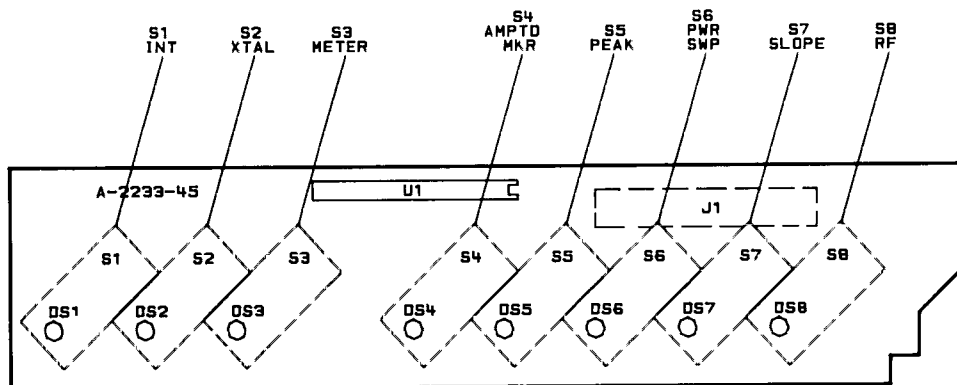

HP Part Number: 08340-60012

Figure A5-2. A7 Lower Keyboard Component Location Diagram

- NOTES:**
1. REFER TO THE SERVICE BEE INT-19.
 2. SCHEMATIC DIAGRAM NOTES.
 3. RESERVE FOR FUTURE USE.

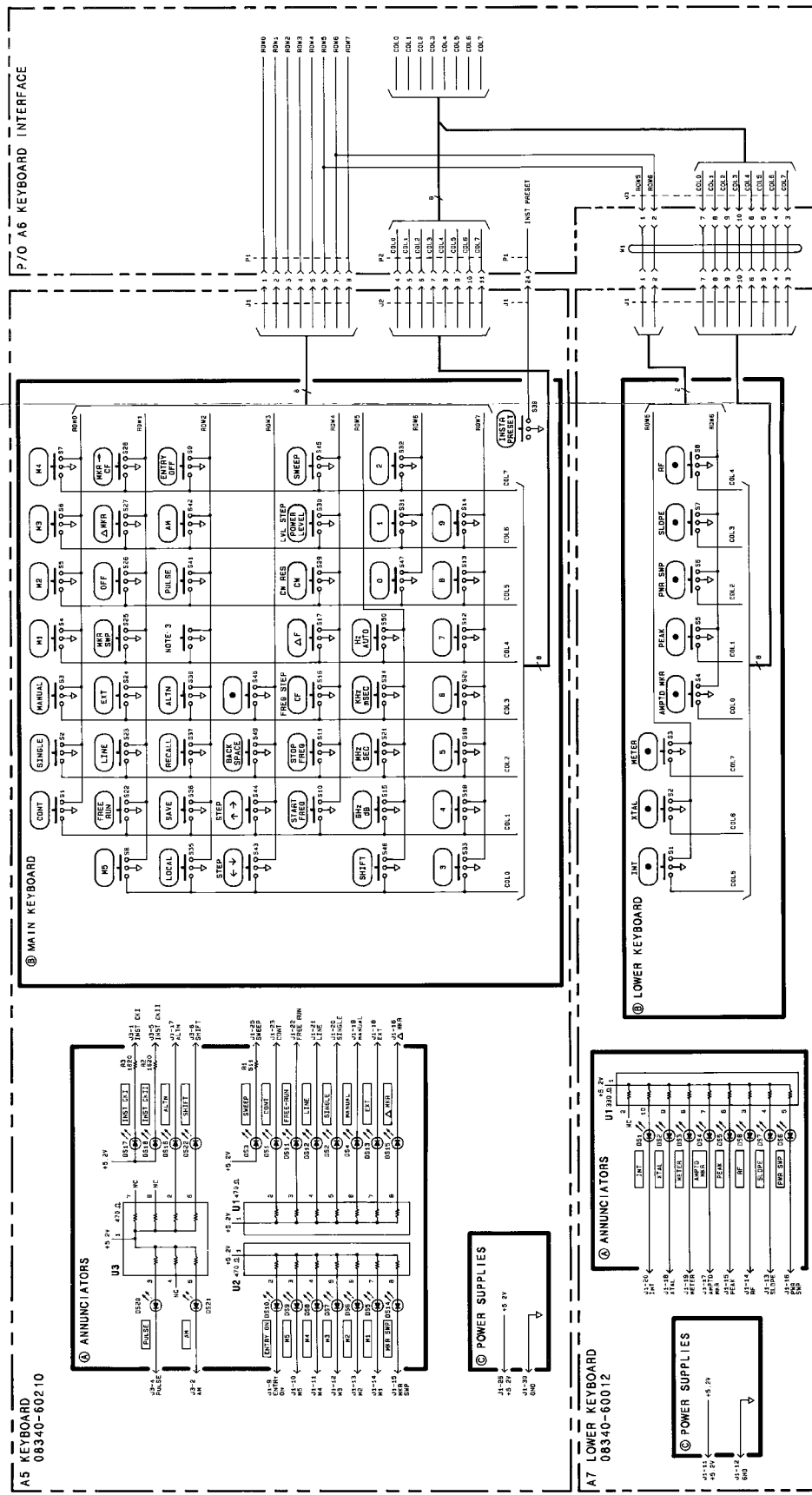

Figure A5-5. A5 Keyboard and A7 Lower Keyboard, Schematic Diagram
Front/Rear Panel

A5 Keyboard and A7 Lower Keyboard Component-Level Troubleshooting

Table A5-1. A5 Keyboard Replaceable Parts

Reference Designation	HP Part Number	C D	Qty	Description	Mfr Code	Mfr Part Number
A5	08340-60210	3	1	KEYBOARD	28480	08340-60210
A5DS1	1990-0858	6	18	L E D (YELLOW) 150 UCD	28480	1990-0858
A5DS2	1990-0858	6		L E D (YELLOW) 150 UCD	28480	1990-0858
A5DS3	1990-0857	5	1	L E D (GREEN) 150 UCD	28480	1990-0857
A5DS4	1990-0858	6		L E D (YELLOW) 150 UCD	28480	1990-0858
A5DS5	1990-0858	6		L E D (YELLOW) 150 UCD	28480	1990-0858
A5DS6	1990-0858	6		L E D (YELLOW) 150 UCD	28480	1990-0858
A5DS7	1990-0858	6		L E D (YELLOW) 150 UCD	28480	1990-0858
A5DS8	1990-0858	6		L E D (YELLOW) 150 UCD	28480	1990-0858
A5DS9	1990-0858	6		L E D (YELLOW) 150 UCD	28480	1990-0858
A5DS10	1990-0858	6		L E D (YELLOW) 150 UCD	28480	1990-0858
A5DS11	1990-0858	6		L E D (YELLOW) 150 UCD	28480	1990-0858
A5DS12	1990-0858	6		L E D (YELLOW) 150 UCD	28480	1990-0858
A5DS13	1990-0858	6		L E D (YELLOW) 150 UCD	28480	1990-0858
A5DS14	1990-0858	6		L E D (YELLOW) 150 UCD	28480	1990-0858
A5DS15	1990-0858	6		L E D (YELLOW) 150 UCD	28480	1990-0858
A5DS16	1990-0858	6		L E D (YELLOW) 150 UCD	28480	1990-0858
A5DS17	1990-0856	4	2	L E D (RED) 150 UCD	28480	1990-0856
A5DS18	1990-0856	4		L E D (RED) 150 UCD	28480	1990-0856
A5DS19	1990-0858	6		L E D (YELLOW) 150 UCD	28480	1990-0858
A5DS20	1990-0858	6		L E D (YELLOW) 150 UCD	28480	1990-0858
A5DS21	1990-0858	6		L E D (YELLOW) 150 UCD	28480	1990-0858
A5DS22	1990-0858	6		L E D (YELLOW) 150 UCD	28480	1990-0858
A5J1	1251-6799	0	1	CONNECTOR HEADER 36 MIR	28480	1251-6799
A5J2	1251-6787	6	2	SOCKET STRIP-6 CONTACT	28480	1251-6787
A5J3	1251-6787	6		SOCKET STRIP-6 CONTACT	28480	1251-6787
A5MP1	0590-0526	6	1	THREADED INSERT-NUT 4-40, 065-IN-LG SST	28480	0590-0526
A5MP2	5041-2732	2	1	KEY CAP "CONT"	28480	5041-2732
A5MP3	5041-2735	5	1	KEY CAP "FREE RUN"	28480	5041-2735
A5MP4	5041-2738	8	1	KEY CAP "LOCAL"	28480	5041-2738
A5MP5	5041-2733	3	1	KEY CAP "SINGLE"	28480	5041-2733
A5MP6	5041-2736	6	1	KEY CAP "LINE"	28480	5041-2736
A5MP7	5041-2739	9	1	KEY CAP "SAVE"	28480	5041-2739
A5MP8	5041-2734	4	1	KEY CAP "MANUAL"	28480	5041-2734
A5MP9	5041-2737	7	1	KEY CAP "EXT"	28480	5041-2737
A5MP10	5041-2731	1	1	KEY CAP "ALT"	28480	5041-2731
A5MP11	5041-2740	2	1	KEY CAP "RECALL"	28480	5041-2740
A5MP12	5041-2712	8	1	KEY CAP "M1"	28480	5041-2712
A5MP13	5041-2713	9	1	KEY CAP "M2"	28480	5041-2713
A5MP14	5041-2725	3	1	KEY CAP "MKR SWP"	28480	5041-2725
A5MP15	5041-0720	4	1	KEY CAP "INST PREST"	28480	5041-0720
A5MP16	5041-2714	0	1	KEY CAP "M3"	28480	5041-2714
A5MP17	5041-0692	9	1	KEY CAP "OFF"	28480	5041-0692
A5MP18	5041-2715	1	1	KEY CAP "M4"	28480	5041-2715
A5MP19	5041-2718	4	1	KEY CAP "MKR DELTA"	28480	5041-2718
A5MP20	5041-2729	7	1	KEY CAP "PULSE"	28480	5041-2729
A5MP21	5041-2716	2	1	KEY CAP "M5"	28480	5041-2716
A5MP22	5041-2726	4	1	KEY CAP "MKR TO CF"	28480	5041-2726
A5MP23	5041-2748	0	1	KEY CAP "AM"	28480	5041-2748
A5MP24	5041-2748	0	1	KEY CAP "ENTRY OFF"	28480	5041-2748
A5MP25	5041-2748	0	2	KEY CAP "ARROW DOWN"	28480	5041-2747
A5MP26	5041-2748	0		KEY CAP "ARROW UP"	28480	5041-2747
A5MP27	5041-2719	5	1	KEY CAP "START FREQ"	28480	5041-2719
A5MP28	5041-2721	9	1	KEY CAP "CF"	28480	5041-2721
A5MP29	5041-2724	2	1	KEY CAP "CW"	28480	5041-2724
A5MP30	5041-2727	5	1	KEY CAP "SWEEP TIME"	28480	5041-2727
A5MP30	5041-2727	5	1	KEY CAP "SWEEP TIME"	28480	5041-2727
A5MP31	5041-2720	8	1	KEY CAP "STOP FREQ"	28480	5041-2720
A5MP32	5041-2722	0	1	KEY CAP "DELTA FREQ"	28480	5041-2722
A5MP33	5041-2723	1	1	KEY CAP "PWR LVL"	28480	5041-2723
A5MP34	5041-2745	7	1	KEY CAP "SHIFT"	28480	5041-2745
A5MP35	5041-0643	0	1	KEY CAP "7"	28480	5041-0643
A5MP36	5041-0640	7	1	KEY CAP "4"	28480	5041-0640
A5MP37	5041-0637	2	1	KEY CAP "1"	28480	5041-0637
A5MP38	5041-0646	3	1	KEY CAP "0"	28480	5041-0646
A5MP39	5041-0644	1	1	KEY CAP "8"	28480	5041-0644
A5MP40	5041-0641	8	1	KEY CAP "5"	28480	5041-0641
A5MP41	5041-0638	3	1	KEY CAP "2"	28480	5041-0638
A5MP42	5041-0647	4	1	KEY CAP "DECIMAL"	28480	5041-0647
A5MP43	5041-0645	2	1	KEY CAP "9"	28480	5041-0645
A5MP44	5041-2747	9	1	KEY CAP "6"	28480	5041-2747
A5MP45	5041-0639	4	1	KEY CAP "3"	28480	5041-0639

A5 Keyboard and A7 Lower Keyboard Component-Level Troubleshooting

Table A5-1. A5 Keyboard Replaceable Parts

Reference Designation	HP Part Number	C D	Qty	Description	Mfr Code	Mfr Part Number
A5MP46	5041-2747	9	1	KEY CAP "BACK SPACE"	28480	5041-2748
A5MP47	5041-2741	3	1	KEY CAP "GHZ/DBM"	28480	5041-2741
A5MP48	5041-2742	4	1	KEY CAP "MHZ/SEC"	28480	5041-2742
A5MP49	5041-2743	5	1	KEY CAP "KHZ/MSEC"	28480	5041-2743
A5MP50	5041-2744	6	1	KEY CAP "HZ AUTO"	28480	5041-2744
A5MP51	5040-8858	3	21	LED STDF STRP, 2 PER	28480	5040-8858
A5MP52	5041-2730	0	1	KEY CAP "FM"	28480	5041-2730
A5R1	0757-0416	7	1	RESISTOR 511 1% 125W F TC=0±100	24546	C4-1/8-T0-511R-F
A5R2	0757-0428	1	2	RESISTOR 1 62K 1% 125W F TC=0±100	24546	C4-1/8-T0-1621-F
A5R3	0757-0428	1	1	RESISTOR 1 62K 1% 125W F TC=0±100	24546	C4-1/8-T0-1621-F
A5S1-50	5060-9436	7	50	PUSHBUTTON SWITCH P.C. MOUNT	28480	5060-9436
A5U1	1810-0203	5	3	NETWORK-RES 8-SIP 470 0 OHM x 7	01121	208A471
A5U2	1810-0203	5		NETWORK-RES 8-SIP 470 0 OHM x 7	01121	208A471
A5U3	1810-0203	5		NETWORK-RES 8-SIP 470 0 OHM x 7	01121	208A471

A5 Keyboard and A7 Lower Keyboard Component-Level Troubleshooting

Table A5-2. A7 Lower Keyboard Replaceable Parts

Reference Designation	HP Part Number	C D	Qty	Description	Mfr Code	Mfr Part Number
A7	08340-60012	3	1	LOWER KEYBOARD ASSEMBLY	28480	08340-60012
A7DS1	1990-0670	0	8	LED (YELLOW) 1 MCD	28480	1990-0670
A7DS2	1990-0670	0		LED (YELLOW) 1 MCD	28480	1990-0670
A7DS3	1990-0670	0		LED (YELLOW) 1 MCD	28480	1990-0670
A7DS4	1990-0670	0		LED (YELLOW) 1 MCD	28480	1990-0670
A7DS5	1990-0670	0		LED (YELLOW) 1 MCD	28480	1990-0670
A7DS6	1990-0670	0		LED (YELLOW) 1 MCD	28480	1990-0670
A7DS7	1990-0670	0		LED (YELLOW) 1 MCD	28480	1990-0670
A7DS8	1990-0670	0		LED (YELLOW) 1 MCD	28480	1990-0670
A7J1	1251-4634	8		CONNECTOR HEADER 20 M2R	28480	1251-4634
A7MP1	5041-0318	6	8	KEY CAP-QUARTER LT PIPE	28480	5041-0318
A7S1	5060-9436	7	8	PUSHBUTTON SWITCH P C MOUNT	28480	5060-9436
A7S2	5060-9436	7		PUSHBUTTON SWITCH P C MOUNT	28480	5060-9436
A7S3	5060-9436	7		PUSHBUTTON SWITCH P C MOUNT	28480	5060-9436
A7S4	5060-9436	7		PUSHBUTTON SWITCH P C MOUNT	28480	5060-9436
A7S5	5060-9436	7		PUSHBUTTON SWITCH P C MOUNT	28480	5060-9436
A7S6	5060-9436	7		PUSHBUTTON SWITCH P C MOUNT	28480	5060-9436
A7S7	5060-9436	7		PUSHBUTTON SWITCH P C MOUNT	28480	5060-9436
A7S8	5060-9436	7		PUSHBUTTON SWITCH P C MOUNT	28480	5060-9436
A7U1	1810-0272	8	1	NETWORK-RES 10-SIP330 0 OHM X	9	01121210A331

A6 Keyboard Interface Circuit Description

ASSEMBLY PURPOSE

The A6 keyboard interface assembly provides the communications link between the instrument microprocessor, the front panel rotary pulse generator (RPG), and A5 and A7 keyboards. The interface contains all data buffers, annunciator latches, and interrupt circuitry to monitor the front panel keyboards and annunciators. RPG control circuitry (counters/timers) and the instrument preset circuitry are also located on the A6 assembly

KEYBOARD ENCODER/DATA BUFFER (BLOCK A)

Two 8-to-3-line priority encoders encode the keyboard row and column information. When you press a key, that key grounds one row line and one column line. The row and column is encoded and presented in active low binary form at the encoder outputs. This information is immediately available at the inputs of the inverting output buffer, which converts the six bits to active-high signals.

Keyboard encoders U10 and U1:

Column or Row Selected	Encoder Output		
	Pin 9	Pin 7	Pin 6
0	1	1	1
1	0	1	1
2	1	0	1
3	0	0	1
4	1	1	0
5	0	1	0
6	1	0	0
7	0	0	0
	LSB		MSB

If you simultaneously press more than one key, the priority encoders only encode the lowest column and row number.

The main instrument microprocessor can disable the encoders with a latched control bit. This control line locks out the keyboard.

If the encoders are not disabled, pressing any key generates a service request (LSRQ) to the instrument processor. The processor then outputs the encoder address and reads the encoded key information.

KEY UP TIMER (DEBOUNCE) (BLOCK B)

Refer to Figure A6-1.

The key released timing function prevents key bounce from causing multiple keydown interrupts to the microprocessor by disabling the key down circuitry as soon as a valid key down is detected, and not re-enabling it until all keys have been up continuously for 50 ms.

When you press a key, the REPEAT DISABLE signal goes high if the KEYBOARD LOCKOUT signal is low. The REPEAT DISABLE signal is inverted twice and combined with the timing one-shot output that goes high for 50 ms after the positive transition of the LOW KEY DOWN signal. The output causes the reset line of a flip-flop to go high, enabling the flip-flop. The key down SRQ line is connected to the clock line, and when a valid key down is detected, the flip-flop is set. The output goes directly to the enable of the key down one-shot (block C), which prevents detecting any further key closures until this enable goes high.

When the key is released the active LOW KEY DOWN line goes high, firing the one-shot for 50 ms, which continues to disable the key down circuitry until it has timed out.

At the end of 100 ms, the one-shot output goes low, causing the key down disable flip-flop to be cleared, which re-enables the key down flip-flop (block C).

KEY DOWN TIMER (BLOCK C)

Refer to Figure A6-1.

The active low keydown signal fires a one-shot set for approximately 20 ms pulses. The output goes low for 20 ms, and on its rising edge it clocks a flip-flop whose input is connected to the active-low keydown signal. If a key is still down at this time, the flip-flop resets indicating that a valid key stroke has been detected. When a valid key stroke is detected, the flip-flop output goes high, producing HI KEY DN SRQ (high key down service request).

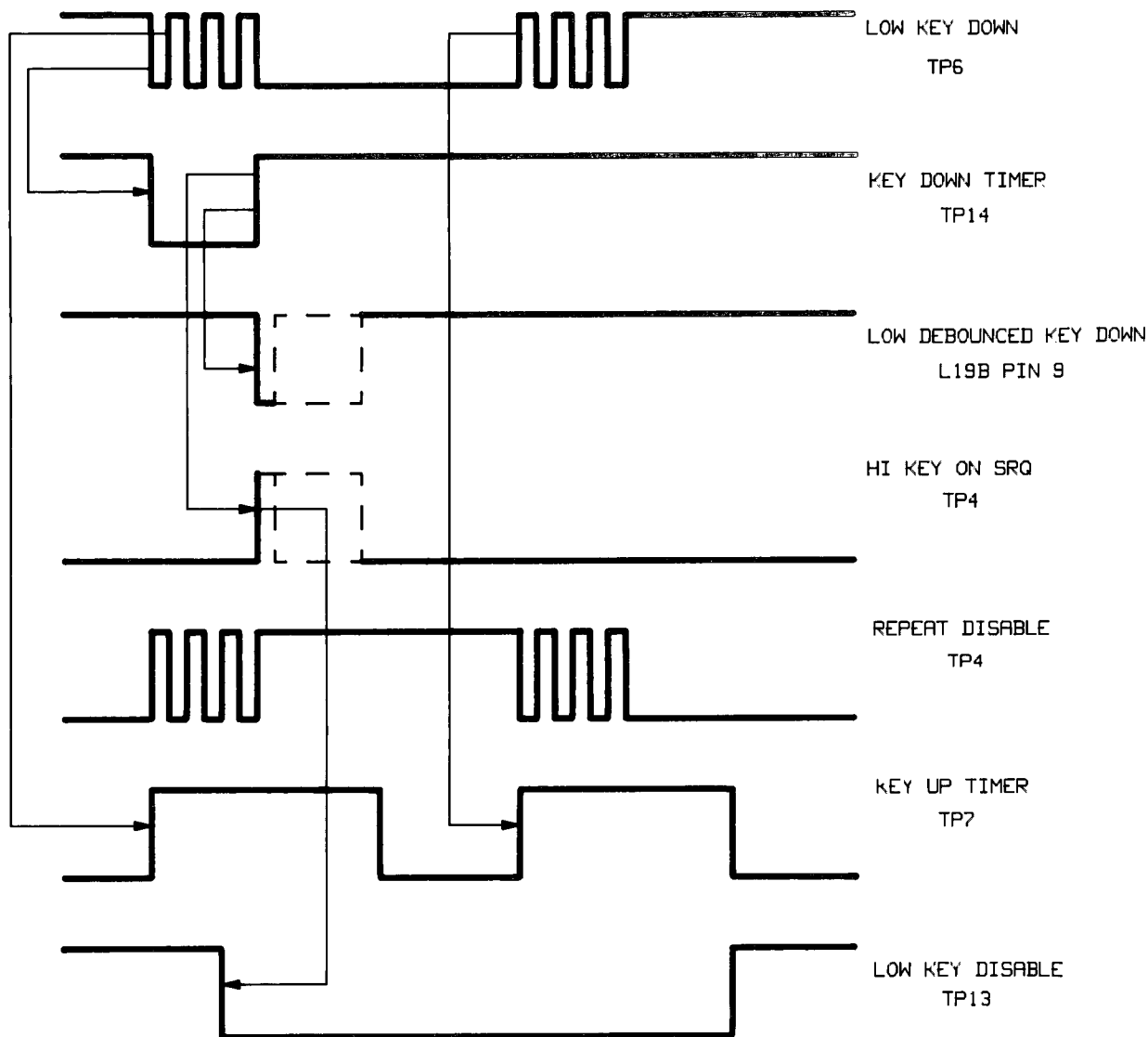

Figure A6-1. Key Up/Down Timing

SRQ BUFFER (BLOCK I)

The HI KEY DN SRQ signal is combined with the active-high RPG SRQ signal to generate LSRQ to the instrument microprocessor.

The HI KEY DN SRQ signal is also present at the keyboard buffer, which contains the encoded key information. When this bit is read by the microprocessor during a LSRQ service routine, it indicates that a key generated the service request.

After reading the encoded information, the microprocessor strobes the address decoder (block F), indicating that key information has been read and preparing the key down timer circuitry for the next keyboard input

REPEAT FUNCTION CIRCUITS (BLOCK D)

The repeat key function consists of two timing circuits. The first is a 500 ms timer, triggered by the output of the key down flip-flop (block C) when a valid key down is detected. After 500 ms, the rising edge of the output of this one-shot clocks a flip-flop. The flip-flop input is connected to the active low KEY DOWN line from the encoders (block A). If a key is still down 500 ms after it is detected, the flip-flop is reset, activating the repeat function. The output of this flip-flop goes high releasing the reset of the second timer and allows it to generate high going pulses at a 5 Hz rate.

The second timer generates an output that goes through an inverter and becomes LOW REPEAT for the key down flip-flop.

RPG COUNTERS DATA BUFFERS (BLOCK G)

When you rotate the front panel knob, the rotary pulse generator (RPG) generates two pulses that are 90 degrees out of phase with each other.

Two 4-bit up/down counters count up or down, depending on the direction you turn the RPG. The two signals from the RPG are connected to the up/down input and to the clock input of each counter. If the clock line goes high while the up/down line is low, the counters count down. If you turn the RPG in the opposite direction, the up/down line is high when the clock line goes high, and the counters count up. When the counter counts down below 0, the output is reset to all ones and counted down again.

The outputs of the up/down counters are always present at the inputs to the non-inverting bus driver from which the instrument processor reads the present count.

The microprocessor clears the up/down counters after it reads the information, to ready them for the next count period.

RPG COUNT WINDOW TIMER (BLOCK H)

The clock line from the RPG that goes to the up/down counters is connected to the clock of a 70 ms one-shot. The first pulse on the RPG clock line fires the one-shot. At the end of 70 ms, the one-shot output clocks a flip-flop. If the RPG is enabled, the input to this flip-flop is low, and the output goes high, causing the LSRQ (block I) line to go low, indicating a service request to the microprocessor. The output also goes to the input of the inverting output buffer in block A. The output of the buffer is read by the microprocessor during the service request routine. A low on this line indicates that the RPG needs microprocessor service.

The RPG SRQ line also goes to the disable count input of the up/down counters in block G, disabling any further counting until the processor services the RPG service request.

After the microprocessor reads the information from the up/down counters, it generates a reset strobe that sets the RPG SRQ flip-flop, clears the up/down counters, and prepares the entire circuit for another cycle.

ANNUNCIATOR LATCHES (BLOCK E)

Four 8-bit latches store LED and control information. Twenty-nine bits control the various front panel LEDs. KEYBOARD LOCKOUT is the lockout for the rest of the keyboard, and prevents any keyboard entries.

The ENTRY ON signal turns on the enabled LED, and enables the RPG SRQ flip-flop in block H. The green SWEEP LED is driven by an inverter controlled by a NAND gate, which forces the LED on when LIPS (low instrument preset) or LSPLD (low sweep LED control) is low.

ADDRESS DECODER (BLOCK F)

The address decoder decodes four strobes from the five address lines and the I/O strobe (SIOB). Outputs clock the annunciator latches in block E, reset the key down and RPG service request circuitry, and act as a read strobe that enables the coded key information, the RPG count information, and the two bits that indicate which circuit requested service onto the bus to be read by the micro-processor.

POWER SWITCH AND STANDBY LED

During standby operation, the power switch grounds the LSBY line, activating the fan relay and signaling the power supplies to turn off.

NOTE: When the fan relay is on, the fan is off.

A6 Keyboard Interface Component-Level Troubleshooting

HOW TO CHECK THE KEYBOARD ENCODER/DATA BUFFER (BLOCK A)

1. Check KEYBOARD LOCKOUT (U1 pin 5). This signal should be low, unless the instrument is in REMOTE mode. If it is high, troubleshoot the annunciator latches (block E).
2. Check LOW KEY DOWN (U10 pin 14). This signal should be high, and go low when a key is pressed. If this signal is correct, go to step 6.
3. If LOW KEY DOWN stays high when a key is pressed, check U10 pin 5 (the enable signal). This signal should also be high and go low when a key is pressed. If the enable signal is correct, go to step 5.

NOTE: If COL 1 or ROW 3 functions incorrectly in step 4 or 5, L STEPUP may be the cause. Troubleshoot L STEPUP before you troubleshoot the keyboard.

4. If the enable signal is not correct, either U1 is bad or the appropriate input to U1 is not being pulled low by the key row. Check the appropriate key row input to U1. This signal should be high and go low each time the associated key is pressed.
 - If the key row functions correctly, replace U1.
 - If the key row does not function correctly, troubleshoot the keyboard (A 5 and A7 Block B).
5. If U10 pin 5 functions correctly, either U10 is bad or the appropriate input to U10 is not being pulled low by the key column. Check the appropriate key column input to U10. This signal should be high and go low each time the associated key is pressed.
 - If the key column functions correctly, replace U10.
 - If the key column does not function correctly, troubleshoot the keyboard (A5 and A7 block B).
6. If all the rest of the A6 assembly circuitry is functioning correctly, but a keystroke or RPG number is not communicated to the instrument, the buffer (U11) may not be functioning correctly. With an oscilloscope, check LEN 7 at U11 pin 1 or 19. Set the oscilloscope to 0.1 μ s/Div. You should find 300 to 400 ns wide, low going pulses each time you press a key, or repetitive pulses if you hold a key down. If not, troubleshoot the address decoder (block F).
7. Using LEN 7 to trigger the oscilloscope, check the outputs of U11 during the output enable pulse. You should find:

• Pin 18	Low if a key is pressed
• Pin 3	Low if the front panel knob is rotated
• Pins 5, 7, 9, 12, 14, and 16	High or Low depending on the key code of the key pressed (see schematic)
8. If one or more output is not correct, check the corresponding input. Because U11 is an inverting buffer you should find the inverted version of the signals described in step 7.
 - If the levels are correct at the input, replace U11.
 - If the signals are not correct, troubleshoot the device(s) from which the incorrect signal(s) come(s).

HOW TO TROUBLESHOOT L STEPUP (BLOCK A)

1. Check the cathode of CR2 or CR3. L STEPUP should be high and only go low when pin 22 on the rear panel 8410 interface connector is grounded. If this signal is high and stays high when the input is shorted to ground, check the front panel ribbon cable and rear panel cable assembly for an open wire. If L STEPUP is low all the time, go to step 3.
2. With the diodes installed, check the voltage at the anode of each diode both with L STEPUP open and with L STEPUP shorted to ground. The anodes should be at approximately 5V when L STEPUP is open and at approximately 0.4V when L STEPUP is shorted to ground. If the voltage at either anode is 0.2V or less when L STEPUP is grounded, that diode is probably shorted. If the voltage at either anode remains at 5V when L STEPUP is grounded, that diode is open.
3. If L STEPUP stays low, lift the cathodes of CR2 and CR3 and check the signal L STEPUP with an ohmmeter to determine if there is a short to ground. If L STEPUP is not shorted to ground, check CR2 and CR3 as described in step 2.
4. Check U10 pin 3 (COL 1) and pin 1 (ROW 3) for a high when no key is pressed. If either signal is low, either the COL or ROW line is shorted, or the encoder (U1 or U10) input is shorted.

HOW TO CHECK THE KEY UP TIMER (BLOCK B)

1. Check KEYBOARD LOCKOUT. This signal should be low unless the instrument is in REMOTE mode. If this signal is not correct, troubleshoot the annunciator latches (block E).
2. With an oscilloscope, check LOW KEY DOWN. Set the oscilloscope to 100 ms/Div. This signal should go low each time a key is pressed, and remain low until the key is released. If this signal is not correct, troubleshoot the keyboard encoder/data buffer (block A).
3. Connect the trigger of the oscilloscope to TP6 (LOW KEY DOWN) and trigger on the rising edge. Set the oscilloscope to 10 ms/div and check TP7 (the output of the key up timer). You should find a high going pulse, 45 to 55 ms wide, each time a key is **released**.
 - If not, replace U9B.
 - If the duration of this pulse is not correct, check/replace R7 or C24.
4. Check TP13 (LOW KEY DISABLE). This signal should go low when HI KEY DN SRQ goes high, and should remain low for 45 to 55 ms after LOW KEY DOWN goes high. If LOW KEY DISABLE is correct, go to step 10.
5. Check U4A pin 1. This signal should go high when a key is pressed, and should remain high for 45 to 55 ms after the key is released. If the signal at U4A pin 1 is **not** correct, go to step 8.
6. Check TP3 (HI KEY DN SRQ). Set the oscilloscope to trigger on the low going edge of TP6 (LOW KEY DOWN). You should find a 100 us to 20 ms wide, high going pulse that occurs 15 to 25 ms after the low going edge of LOW KEY DOWN. If HI KEY DN SRQ is not correct, troubleshoot the key down timer (block C).
7. If HI KEY DN SRQ is correct, check U4A pins 2 and 4 to make sure they are pulled high by R11. If these inputs are also correct, replace U4.

8. Check TP4 (U14D pin 12). Set the oscilloscope to 100 ns/Div, and trigger on the high going edge of LOW KEY DOWN. This signal should remain high for a minimum of 100 ns after a key is **released**. If it is low all the time, either U8 or U14 is bad.
9. If the signal at TP4 says high, check U14B pin 4 (REPEAT DISABLE). REPEAT DISABLE should be an inverted version of LOW KEY DOWN. If it is not, replace U14. If it is correct, either U8 is bad or C23 is shorted.
10. If LOW KEY DISABLE is correct, probe U4A pin 5 (REPEAT RESET) This signal should go high when HI KEY DN SRQ goes high, and remain high for 45 to 55 ms after LOW KEY DOWN goes high
11. If REPEAT RESET is not correct, either the output of U4A is bad or the input to U9A pin 3 is bad Lift U4A pin 5, recheck for the correct signal at U4A pin 5, and replace the appropriate part.

HOW TO CHECK THE KEY DOWN TIMER (BLOCK C)

1. Check U8C pin 5 (KEYBOARD LOCKOUT). This signal should be low unless the instrument is in REMOTE mode. If not, troubleshoot the annunciator latches (block E).
2. Check the output of U8C pin 6. This signal should be an inverted version of KEYBOARD LOCKOUT. If not, replace U8.
3. Check U20 pin 10 (LOW KEY DISABLE) This signal should go low when HI KEY DN SRQ goes high, and should remain low for 45 to 55 ms after LOW KEY DOWN goes high. If not, troubleshoot the key up timer (block B).
4. Check LOW KEY DOWN. Set the oscilloscope to 100 ms/Div. This signal should go low each time a key is pressed and remain low until the key is released. If not, troubleshoot the keyboard encoder/data buffer (block A).
5. Connect the trigger of the oscilloscope to TP6 (LOW KEY DOWN) and trigger on the falling edge. Set the oscilloscope to 10 ms/Div and check TP14 (the output of the key down timer). You should find a 15 to 25 ms wide, low going pulse each time a key is pressed. If not, replace U20B. If the pulse is there, but the duration is not correct, check/replace R5 or C17.
6. Check HI KEY DN SRQ. Each time a key is pressed you should find a 100 us to 20 ms wide, high going pulse that starts at the same time that the output of the key down timer (TP14) goes high. If HI KEY DN SRQ is correct, go to step 10.
7. Check TP12 (LOW REPEAT). This signal should remain high unless a key is held down for longer than approximately one-half second. If not, troubleshoot the repeat function circuits (block D).
8. Check U19B pin 10 (LEN 6) Set the oscilloscope to 0.2 us/Div. You should find a low going, 300 to 400 ns wide pulse each time a key is pressed (this signal may be difficult to find unless you use a storage scope. Refer to HOW TO CHECK THE ADDRESS DECODER for further information). If the signal is not present, troubleshoot the address decoder (block F).
9. If LEN 6 is correct, either the output of U19B (pin 8) is bad or one of the three destinations of HI KEY DN SRQ is bad (U11 Block A, U4 Block B, U19 Block C, or U3 Block I). Determine and replace the defective part.
10. If HI KEY DN SRQ is correct, check U19B pin 9 (LOW DEBOUNCED KEY DOWN). You should find low going, 15 to 25 ms wide pulses that start when the signal at TP14 goes high.

11. If LOW DEBOUNCED KEY DOWN is not correct, either the output of U19B is bad or U9A pin 1 (Block D) input is bad.

HOW TO CHECK THE REPEAT FUNCTION CIRCUITS (BLOCK D)

1. With an oscilloscope, check U9A pin 3 (REPEAT RESET). Set the oscilloscope to 20 ms/Div and trigger off the LOW going edge of LOW KEY DOWN (TP6). REPEAT RESET should go high 15 to 25 ms after LOW KEY DOWN goes low, and should remain high for 45 to 55 ms after LOW KEY DOWN goes high. If not, troubleshoot the key up timer (block C).
2. Check U9 pin 1 (LOW DEBOUNCED KEY DOWN). This signal should go low 15 to 25 ms after LOW KEY DOWN goes low, and remain low 100 us to 20 ms (depending on how quickly the micro-processor services the HI KEY DN SRQ). If this not, troubleshoot the key down timer (block C).
3. Check U4 pin 10 (REPEAT DISABLE) This signal should go high when a key is pressed and go low as soon as the key is released. If not, troubleshoot the key up timer (block B)
4. Check TP9 (U9A pin 4). Set the oscilloscope to 100 ms/Div and trigger on the high going edge of HI KEY DN SRQ (A6TP3). Press any key and hold it down. This signal should go low for approximately 400 ms, and then go high for approximately 100 ms. If there is no signal, replace U9. If signal is present, but the duration is not correct, check/replace R3 or C7.
5. Check TP5 (U4 pin 8). Press any key and hold it down. TP5 should be low and remain low for approximately 400 ms. It should then go high and remain high until the key is released. If the signal at TP5 is correct, go to step 7.
6. Lift U4B pin 8 and check at the pin for the signal described in step 5. If this signal is now correct, check for shorts along the trace. If there are no shorts, replace U5. If the signal is not correct after you replace U5, replace U4.
7. Check U5 pin 3. Set the oscilloscope to 50 ms/Div and select rising edge triggering. When you press and hold a key you should find a high going pulse every 100 ms. If this signal is correct, go to step 9.
8. If the signal at U5 pin 3 goes high (when U5 Pin 4 goes high) and remains high until the key is released, C8 is shorted. If the signal is a square wave, CR1 is probably open.
9. Adjust the oscilloscope to 20 us/Div. Verify that the high going pulses are approximately 20 us wide. If the 20 us wide, high going pulses are spaced very close together (< 100 ms), CR1 is probably shorted.
10. If the signal at U5 pin 3 is correct, check TP12 (LOW REPEAT) Set the oscilloscope to 50 ms/Div and triggering on the low going edge of this signal. You should find an inverted version of the signal at U5 pin 3.

HOW TO CHECK THE ANNUNCIATOR LATCHES (BLOCK E)

1. Check U6 pin 1 (ANNUNCIATOR RESET). This signal should be high, and go low when you press [INSTR PRESET]. If not, troubleshoot the instrument preset buffer (block J).
2. Check U6 pin 11 (LEN 5). Set the oscilloscope to 200 ns/Div and trigger on the low going edge of this pulse. You should find a low going, 300 to 400 ns wide pulse each time you press a key that has a LED associated with it. If not, troubleshoot the address decoder (block F).

If One Or More Front Panel LEDs Never Light

1. Perform steps 1, 2, and 3 at the beginning of the HOW TO CHECK ANNUNCIATOR LATCHES.
2. Check the voltage at the appropriate output of the annunciator latches (U6, U7, U16, or U17). When you press [INSTR PRESET], the voltage at all of the outputs should be low (approximately 0.4V). If the appropriate output is low, but the LED is off, replace the LED.

If One Or More Annunciator Latch Outputs are Not Correct

1. Perform steps 1, 2, and 3 at the beginning of HOW TO CHECK ANNUNCIATOR LATCHES.
2. If one or more of the outputs from the annunciator latches (U6, U7, U16, and U17) is not correct, connect A60TP13 (LSTS) to ground to enable the instrument digital signal analysis.
3. To verify that a suspected latch output is not working, set the oscilloscope to 100 us/Div and check that output. If the output is working, you should find TTL activity (< 0.4V for low and > 3.5V for high).
4. Check the appropriate data bus input for this section of the latch. Set the oscilloscope to 10 us/Div and triggering on the low going edge of this signal. You should find a series of low going pulses, 2 to 4 us wide. The low level should be very near 0V and the high level should be very near +5V. If the signal is correct, proceed to step 6.
5. Check the same data bus line at the motherboard end of the front panel ribbon cable. If the signal appears correctly at the motherboard, repair or replace the ribbon cable. If no signal appears at the motherboard, refer to the A60 processor troubleshooting.
6. For control signals, troubleshoot the following:

Bad Signal	Troubleshoot
ENTRY ON (U6 pin 19)	RPG Count Window Timer (block H)
KEYBOARD LOCKOUT (U6 pin 2)	Key Up Timer (block B) Keyboard Encoder/Data Buffer (block A) Key Down Timer (block C)
INSTR PRESET LOCKOUT (U16 pin 2)	Instrument Preset Buffer (block J)

If the Front Panel SWEEP LED Does Not Operate Correctly

1. With the instrument sweeping, check U2D pin 13 (LSPLD). Set the oscilloscope to approximately the same ms/Div as the sweep time of the synthesizer. You should find both high and low TTL levels, with the low level corresponding to when the sweep LED should be on. If LSPLD is correct, proceed to step 4.
2. Measure LSPLD at the motherboard end of the ribbon cable. If the signal is present at the motherboard, replace the ribbon cable.
3. If no signal appears at the motherboard, disconnect the 50 pin ribbon cable from the keyboard interface assembly and recheck for this signal. If there still is no signal at the motherboard, check for this signal on the A58 sweep generator. If the signal is present, check for shorts along the signal path on the A6 assembly. If there are no shorts, replace U2.
4. Check U2D pin 11. You should find an inverted version of LSPLD. If not, check for shorts along the signal path. If there are no shorts, replace U2.
5. Check the signal at U2 pin 8. It should be the same as LSPLD. If the signal at U2 pin 8 is correct, but the SWEEP LED is not flashing, replace the green SWEEP LED. If the signal at U2 pin 8 is not correct, check for shorts along the signal path. If there are no shorts, replace U2.

HOW TO CHECK THE ADDRESS DECODER (BLOCK F)

1. Measure the voltage between U15 pin 8 (GND) and chassis ground. If this voltage is not 0V, repair/replace the front panel ribbon cable.
2. Ground A60TP13 to place the instrument into the DSA mode. Check U15 pins 1 through 6 (A0 through A4 and SIOB). Set the oscilloscope to 2 us/Div and triggering on the low going edge. You should find bus activity (both high and low levels) on every line. If the signals are present, go to step 5.
3. At the motherboard end of the ribbon cable, measure the signal(s) not present in step 2. If a signal is present at the motherboard, replace the ribbon cable.
4. If no signal appears at the motherboard, disconnect the 50 pin ribbon cable from the A6 assembly and recheck for the signal. If there is still no signal at the motherboard, troubleshoot the signal on the A60 processor assembly. If the signal is present, check for shorts along the signal path on the A6 assembly. If there are no shorts, replace U15.
5. If all of the inputs to U15 are correct, check U15 pins 7, 9, 10, and 11 (LEN 4 through LEN7). Set the oscilloscope to 200 ns/Div. You should find 200 to 400 ns wide, low going pulses. If LEN 4 through LEN 7 are correct, the address decoder is operating properly.

HOW TO CHECK THE RPG COUNTERS/DATA BUFFERS (BLOCK G)

1. Check TP1 (CLK). Set the oscilloscope to 10 ms/Div. You should find a repetitive TTL signal when you rotate the front panel knob. If the signal is present, proceed to step 3
2. Remove the 902 (white/black/red) wire from the RPG connector and check CLK right at the wire. If the signal is not present, replace the RPG. If the signal is present, C25 may be shorted. If not, replace U8.
3. Check the U8E pin 10. The inverted version of CLK should be present. If the signal is correct, proceed to step 5.
4. If the signal is not present at U8E pin 10, either U8 is bad or one of the inputs driven by this signal is preventing the signal from changing
5. Check TP2 (UP/DOWN). Set the oscilloscope to 10 ms/div. You should find a repetitive TTL signal when the RPG is rotated. If the signal is present, proceed to step 7.
6. Remove the 901 (white/black/brown) wire from the RPG connector and check the signal at the wire. If the signal is not present, replace the RPG. If the signal is present, C26 may be shorted. If not, replace U8.
7. Check the U8E pin 12. The inverted version of UP/DOWN should be present. If the signal is correct, proceed to step 9.
8. If the signal is not present at U8E pin 12, either U8 is bad or one of the inputs driven by this signal is preventing the signal from changing
9. Check U13 or U18 pin 8 (LEN 6) and U 12 pin 1 or 19 (LEN 7). Set the oscilloscope to 200 ns/Div and trigger on the low going edge. You should find 200 to 400 ns wide, low going pulses each time you rotate the RPG. If not, troubleshoot the address decoder (block F)
10. Check U13 or U18 pin 7 (HI RPG SRQ). Set the oscilloscope to 20 ms/division. HI RPG SRQ should be low, and go high for 100 us to 20 ms each time you rotate the front panel knob. If not, troubleshoot the RPG count window timer (block H).
11. Check the U13 and U18 pins 13 through 16 and pin 19. Set the oscilloscope to 20 ms/Div and trigger on the high going edge. Each time you rotate the front panel knob (very slowly counter clockwise) you should find a series of pulses on these pins. If not, either U13 or U18 is bad or, the input to the bus buffer (U12) is bad.
12. Check U12 pins 3, 5, 7, 9, 12, 14, 16, and 18. Set the oscilloscope to 200 ns/Div and trigger on the low going edge of LEN7 (U12 pin 1 or 19). Rotate the front panel knob slowly in both directions and verify that both high and low levels are present at each output of U12 during the first 200 to 400 ns after the trigger. If not, replace U12.
13. If all of the outputs are correct, but you still suspect that the microprocessor is not getting the data, verify that these signals are getting through the front panel ribbon cable by checking at the motherboard Set the oscilloscope as in step 12. Note that if one of these data lines is open, several front panel LEDs will also be incorrect.

HOW TO CHECK THE RPG COUNT WINDOW TIMER (BLOCK H)

1. Check U13 or U18 pin 8 (LEN 6) and U12 pin 1 or 19 (LEN 7). Set the oscilloscope to 200 ns/Div and trigger on the low going edge. You should find 200 to 400 ns wide, low going pulses each time you rotate the front panel knob. If not, troubleshoot the address decoder (block F).
2. Check U19A pin 2 (ENTRY ON). This signal should be low when an active function is displayed in the entry display. Press **[START FREQ]**; the signal should go low. If not, troubleshoot the annunciator latches (block E).
3. Check U20 pin 2 (CLK). Set the oscilloscope to 10 ms/Div. You should find a repetitive TTL signal when you rotate the front panel knob. If not, troubleshoot the RPG counters/data buffer (block G).
4. Connect the trigger of the oscilloscope to TP1 (CLK) and trigger on the falling edge. Check TP15 (the output of the RPG count window timer). You should find a low going pulse 65 to 75 ms wide each time you rotate the front panel knob. If not, replace U20. If the duration of this pulse is not correct, check/replace R6 or C22.
5. Check U19A pin 6 (HI RPG SRQ). Each time you rotate the front panel knob, you should find a 100 us to 20 ms wide, high going pulse that goes high when TP15 goes high.

HOW TO CHECK THE SERVICE REQUEST BUFFER (BLOCK I)

1. Check U3A pin 1 (LSRQ). Set the oscilloscope 100 us/Div and trigger on the low going edge. Press **[CW]** and rotate the front panel knob. You should find a 100 us wide, low going pulse each time you rotate the RPG. If so, proceed to step 4.
2. Check TP8 (HI RPG SRQ). Set the oscilloscope to trigger on the high going edge. Each time you rotate the front panel knob, you should find a 100 us wide, high going pulse. If so, replace U3.
3. Press any key; You should find a 100 us wide, low going pulse on U3A pin 1 (LSRQ) when the key is pressed.
4. If LSRQ is not correct, check TP3 (HI KEY DN SRQ). Set the oscilloscope to trigger on the high going edge. Each time you press a key, you should see a 100 us wide high going pulse. If so, replace U3.
5. If TP3 is not correct, the problem can be either U3, or the low down timer (block C).

HOW TO CHECK THE INSTRUMENT PRESET BUFFER (BLOCK J)

1. Check U3D pin 12 (INSTR PR LOCKOUT). This signal should be low unless the instrument is in REMOTE mode. If this signal is high, troubleshoot the annunciator latches (block E).
2. Check U3D pin 11 (INSTR PRESET). This signal should be high and go low when you press **[INSTR PRESET]**. If this signal is correct, proceed to step 6.
3. If INSTR PRESET stays high, check for an open circuit on both the A5 and the A6 assemblies. You can manually ground this signal at A6P1 pin 24 to verify that the signal at U3D pin 11 goes low at the same time. This cuts the problem in half.

4. If INSTR PRESET is low, disconnect the A6 assembly from the A5 keyboard. If INSTR PRESET is now correct, remove the INSTR PRESET key switch from the A5 keyboard and check for shorts. If no shorts exist, replace the key switch.
5. If INSTR PRESET is correct, check U3D pin 13. The signal at this pin should be low, and go high when INSTR PRESET goes low. If not, check for shorts along the trace. If there are no shorts, replace U3.
6. Check U3C pin 10 (LIPS) LIPS should be high and go low when you press **[INSTR PRESET]**. If LIPS is correct, go to step 9.
7. If LIPS is always low, disconnect the front panel ribbon cable from the A6 assembly and check LIPS on the motherboard. If LIPS is still low, troubleshoot the A52 assembly or the A60 assembly.
8. If LIPS is correct, the problem can be U3, a short along the signal trace, or U8.
9. Check U8A pin 2. This signal should be low and go high when you press **[INSTR PRESET]**. If so, go to step 10.
11. If the signal at U8 pin 2 is correct, check U2 pin 3 (ANNUNCIATOR RESET). This signal should be high and go low when you press **[INSTR PRESET]**.

A6 KEYBOARD INTERFACE SIGNATURE ANALYSIS

A limited amount of digital signature analysis (DSA) is available on the keyboard interface. All of the latched LED bits and control Bits, as well as the strobes, can be tested for correct operation by using the main instrument DSA routine below, and a signature analyzer.

1. Ground the A60TP13. Turn the instrument to STANDBY and then on.
2. Connect Signature Analyzer as follows:

START	A60TP3
Trigger	Rising edge
STOP	A60TP4
Trigger	Rising edge
CLOCK	A60TP25
Trigger	Rising edge
GRND	Chassis ground or ground pin.

A6 Keyboard Interface Component-Level Troubleshooting

3. Check the following signatures.

Mnemonic	A6J3 Pin #	Signature
DB0 DB1	3 4	H186 CFPH
DB2 DB3	5 6	H077 0942
DB4 DB5	7 8	CC29 63CP
DB6 DB7	9 10	F77H 2757
DB8 DB9	11 12	P702 67A8
DB10 DB11	13 14	FU51 9PA2
DB12 DB13	15 16	3H44 37FH
DB14 DB15	17 18	CF15 H186
ADR0 ADR1	23 24	AUCU U154
ADR2 ADR3	25 26	012F 8U24
ADR4 SIOB	27 47	7UUF 3704

Mnemonic	A6U15 Pin #	Signature
LEN 4	11	P769
LEN 5	10	U034
LEN 6	9	FAFP

A6 Keyboard Interface Component-Level Troubleshooting

Mnemonic	A6U6 Pin #	Signature
MKR SWP M1	12 9	8H01 2156
M2 M3	15 6	79U9 F8A6
M4 M5	16 5	AA19 H973
ENTRY ON KEYBOARD LOCKOUT	19 2	AP4U 7C63

Mnemonic	A6U7 Pin #	Signature
ALTN EXT	19 2	FH92 A070
SINGLE MAN	16 5	5F49 C892
FREE LINE	15 6	7124 F5C5
CONT DELTA MRKR	12 9	C03U 5C2A

Mnemonic	A6U16 Pin #	Signature
PEAK XTAL	12 9	CC23 0UFP
AMPTD MRKR PWR SWP	15 6	6614 C5A1
INT RF	16 5	12FC 10PH
EXT INST PR LOCKOUT	19 2	H7A5 20CH

A6 Keyboard Interface Component-Level Troubleshooting

Mnemonic	A6U17 Pin #	Signature
AM SLOPE	19 2	38U3 086U
PULSE INST CK I	16 5	P6A0 FH41
INST CK II FM	15 6	9A82 CAU3
SHIFT	12 9	0F6P 6155

A6 Keyboard Interface Component-Level Troubleshooting

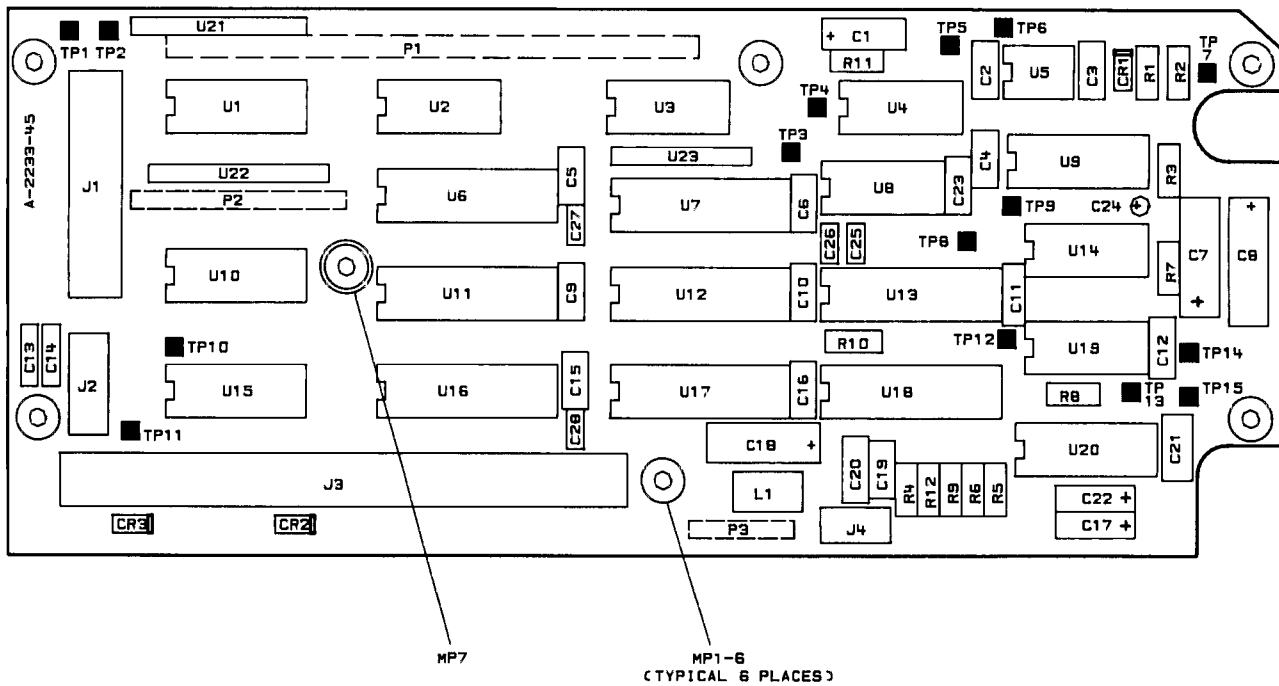

HP Part Number: 08340-60235

Figure A6-2. A6 Keyboard Interface Component Location Diagram

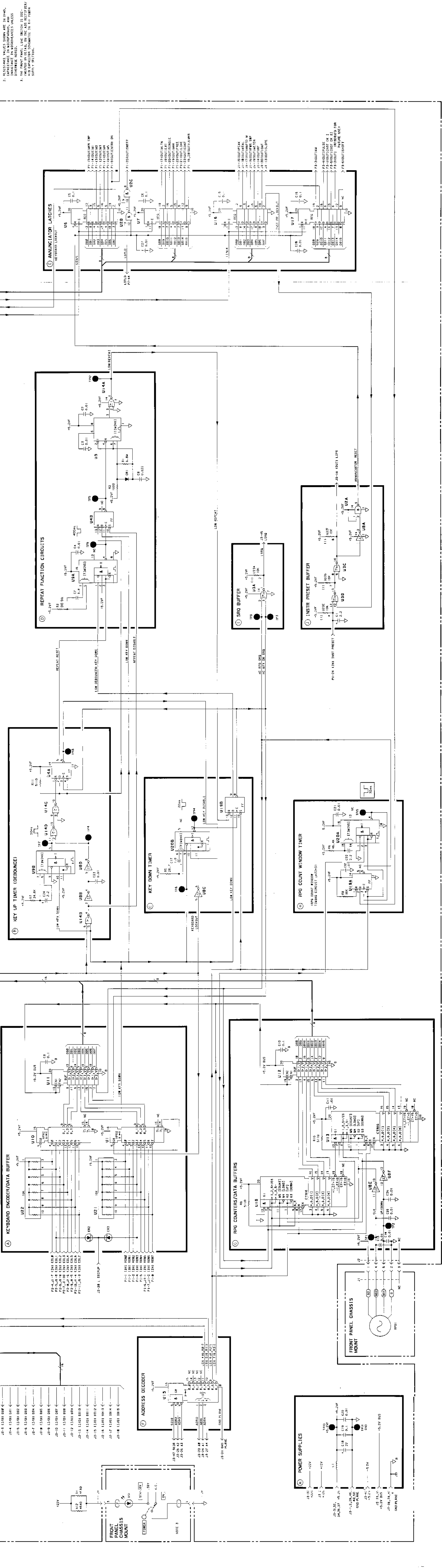

Figure A6-3. A6 Keyboard Interface Schematic Diagram
 Front/Rear Panel A6-19/A6-20

- NOTES:
1. REFER TO THE SERVICE BEEZ ZIMRO FOR THE MECHANICAL SYMBOLS.
 2. RESISTANCE VALUES SHOWN ARE IN OHMS, CAPACITANCE IN MICROFARADS, AND DIMENSIONS UNLESS OTHERWISE NOTED.
 3. THE FRONT PANEL LINE SWITCH IS IDENTIFIED IN DETAIL ON THE ASSEMBLY SUPPLY SECTION.

A6 Keyboard Interface Component-Level Troubleshooting

Table A6-1. A6 Keyboard Interface Replaceable Parts

Reference Designation	HP Part Number	C D	Qty	Description	Mfr Code	Mfr Part Number
A6	08340-60235	2	1	KEYBOARD INTERFACE	28480	08340-60235
A6C1	0180-0197	8	2	CAPACITOR-FXD 2.2UF ± 10% 20VDC TA	56289	150D225X9020A2
A6C2	0160-2055	9	10	CAPACITOR-FXD 01UF + 80-20% 100VDC CER	28480	0160-2055
A6C3	0160-2055	9		CAPACITOR-FXD 01UF + 80-20% 100VDC CER	28480	0160-2055
A6C4	0160-2055	9		CAPACITOR-FXD 01UF + 80-20% 100VDC CER	28480	0160-2055
A6C5	0160-4084	8	7	CAPACITOR-FXD 1UF ± 20% 50VDC CER	28480	0160-4084
A6C6	0160-4084	8		CAPACITOR-FXD 1UF ± 20% 50VDC CER	28480	0160-4084
A6C7	0180-0116	1	1	CAPACITOR-FXD 6.8UF ± 10% 35VDC TA	56289	150D685X9035B2
A6C8	0160-0162	5	1	CAPACITOR-FXD 022UF ± 10% 200VDC POLYE	28480	0160-0162
A6C9	0160-4084	8		CAPACITOR-FXD 1UF ± 20% 50VDC CER	28480	0160-4084
A6C10	0160-4084	8		CAPACITOR-FXD 1UF ± 20% 50VDC CER	28480	0160-4084
A6C11	0160-2055	9		CAPACITOR-FXD 01UF + 80-20% 100VDC CER	28480	0160-2055
A6C12	0160-2055	9		CAPACITOR-FXD 01UF + 80-20% 100VDC CER	28480	0160-2055
A6C13	0160-2055	9		CAPACITOR-FXD 01UF + 80-20% 100VDC CER	28480	0160-2055
A6C14	0160-2055	9		CAPACITOR-FXD 01UF + 80-20% 100VDC CER	28480	0160-2055
A6C15	0160-4084	8		CAPACITOR-FXD 1UF ± 20% 50VDC CER	28480	0160-4084
A6C16	0160-4084	8		CAPACITOR-FXD 1UF ± 20% 50VDC CER	28480	0160-4084
A6C17	0180-0291	3	1	CAPACITOR-FXD 1UF ± 10% 35VDC TA	56289	150D105X9035A2
A6C18	0180-0228	6	1	CAPACITOR-FXD 22UF ± 10% 15VDC TA	56289	150D226X9015B2
A6C19	0160-4084	8		CAPACITOR-FXD 1UF ± 20% 50VDC CER	28480	0160-4084
A6C20	0160-2055	9		CAPACITOR-FXD 01UF + 80-20% 100VDC CER	28480	0160-2055
A6C21	0160-2055	9		CAPACITOR-FXD 01UF + 80-20% 100VDC CER	28480	0160-2055
A6C22	0180-0197	8		CAPACITOR-FXD 2.2UF ± 10% 20VDC TA	56289	150D225X9020A2
A6C23	0160-2055	9		CAPACITOR-FXD 01UF + 80-20% 100VDC CER	28480	0160-2055
A6C24	0180-2731	0	1	CAPACITOR-FXD 2.2UF ± 10% 20VDC TA	28480	0180-2731
A6C25	0160-3879	7	4	CAPACITOR-FXD 01UF ± 20% 100VDC CER	28480	0160-3879
A6C26	0160-3879	7		CAPACITOR-FXD 01UF ± 20% 100VDC CER	28480	0160-3879
A6C27	0160-3879	7		CAPACITOR-FXD 01UF ± 20% 100VDC CER	28480	0160-3879
A6C28	0160-3879	7		CAPACITOR-FXD 01UF ± 20% 100VDC CER	28480	0160-3879
A6CR1	1901-0050	3	1	DIODE-SWITCHING 80V 200MA 2NS DO-35	28480	1901-0050
A6CR2	1901-0518	8	2	DIODE-SM SIG SCHOTTKY	28480	1901-0518
A6CR3	1901-0518	8		DIODE-SM SIG SCHOTTKY	28480	1901-0518
A6J1	1251-4634	8	2	CONNECTOR HEADER 20 M2R	28480	1251-4634
A6J2	1251-6868	4	1	CONNECTOR HEADER 5 M IR	28480	1251-6868
A6J3	1251-5746	5	1	CONNECTOR HEADER 50 M2R	28480	1251-5746
A6J4	1251-6793	4	1	CONNECTOR HEADER 3 M IR	28480	1251-6793
A6L1	9100-1788	6	1	CHOKER-WIDE BAND ZMAX=680 OHM@ 180 MHZ	02114	VK200 20/48
A6MP1	0380-0043	7	6	SPACER-RVT-ON 375-IN-LG 14-IN-ID	28480	0380-0043
A6MP2	0380-0043	7		SPACER-RVT-ON 375-IN-LG 14-IN-ID	28480	0380-0043
A6MP3	0380-0043	7		SPACER-RVT-ON 375-IN-LG 14-IN-ID	28480	0380-0043
A6MP4	0380-0043	7		SPACER-RVT-ON 375-IN-LG 14-IN-ID	28480	0380-0043
A6MP5	0380-0043	7		SPACER-RVT-ON 375-IN-LG 14-IN-ID	28480	0380-0043
A6MP6	0380-0043	7		SPACER-RVT-ON 375-IN-LG 14-IN-ID	28480	0380-0043
A6MP7	0380-0111	0	1	STANDOFF-RVT-ON 25-IN-LG 6-32THD	00000	ORDER BY DESCRIPTION
A6P1	1251-6787	6	5	SOCKET STRIP 6 CONTACT	28480	1251-6787
A6P2	1251-6799	0	2	CONNECTOR HEADER 36 M IR	28480	1251-6799
A6P3	1251-6799	0		CONNECTOR HEADER 36 M IR	28480	1251-6799
A6R1	0683-6855	3	1	RESISTOR 6.8M 5% .25W FC TC=-900/+1100	01121	CB6855
A6R2	0757-0280	3	1	RESISTOR 1K 1% .125W F TC=0±100	24546	C4-1/8-T0-1001-F
A6R3	0757-0464	5	1	RESISTOR 90.9K 1% .125W F TC=0±100	03292	C4-1/8-T0-9092-F
A6R4	0698-3155	1	2	RESISTOR 4.64K 1% .125W F TC=0±100	24546	C4-1/8-T0-4641-F
A6R5	0698-3449	6	1	RESISTOR 28.7K 1% .125W F TC=0±100	24546	C4-1/8-T0-2872-F
A6R6	0698-3162	0	1	RESISTOR 46.4K 1% .125W F TC=0±100	24546	C4-1/8-T0-4642-F
A6R7	0757-0123	3	1	RESISTOR 34.8K 1% .125W F TC=0±100	28480	0757-0123
A6R8	0757-0442	9	1	RESISTOR 10K 1% .125W F TC=0±100	24546	C4-1/8-T0-1002-F
A6R9	0757-0438	3	3	RESISTOR 5.11K 1% .125W F TC=0±100	24546	C4-1/8-T0-5111-F
A6R10	0757-0438	3		RESISTOR 5.11K 1% .125W F TC=0±100	24546	C4-1/8-T0-5111-F
A6R11	0757-0438	3		RESISTOR 5.11K 1% .125W F TC=0±100	24546	C4-1/8-T0-5111-F
A6R12	0698-3155	1		RESISTOR 4.64K 1% .125W F TC=0±100	24546	C4-1/8-T0-4641-F
A6TP1	0360-0535	0	15	TERMINAL TEST POINT PCB	00000	ORDER BY DESCRIPTION
A6TP2	0360-0535	0		TERMINAL TEST POINT PCB	00000	ORDER BY DESCRIPTION
A6TP3	0360-0535	0		TERMINAL TEST POINT PCB	00000	ORDER BY DESCRIPTION
A6TP4	0360-0535	0		TERMINAL TEST POINT PCB	00000	ORDER BY DESCRIPTION
A6TP5	0360-0535	0		TERMINAL TEST POINT PCB	00000	ORDER BY DESCRIPTION
A6TP6	0360-0535	0		TERMINAL TEST POINT PCB	00000	ORDER BY DESCRIPTION
A6TP7	0360-0535	0		TERMINAL TEST POINT PCB	00000	ORDER BY DESCRIPTION
A6TP8	0360-0535	0		TERMINAL TEST POINT PCB	00000	ORDER BY DESCRIPTION
A6TP9	0360-0535	0		TERMINAL TEST POINT PCB	00000	ORDER BY DESCRIPTION
A6TP10	0360-0535	0		TERMINAL TEST POINT PCB	00000	ORDER BY DESCRIPTION

A6 Keyboard Interface Component-Level Troubleshooting

Table A6-1. A6 Keyboard Interface Replaceable Parts

Reference Designation	HP Part Number	C	D	Qty	Description	Mfr Code	Mfr Part Number
A6TP11	0360-0535	0			TERMINAL TEST POINT PCB	00000	ORDER BY DESCRIPTION
A6TP12	0360-0535	0			TERMINAL TEST POINT PCB	00000	ORDER BY DESCRIPTION
A6TP13	0360-0535	0			TERMINAL TEST POINT PCB	00000	ORDER BY DESCRIPTION
A6TP14	0360-0535	0			TERMINAL TEST POINT PCB	00000	ORDER BY DESCRIPTION
A6TP15	0360-0535	0			TERMINAL TEST POINT PCB	00000	ORDER BY DESCRIPTION
A6U1	1820-1851	2		2	IC ENCDR TTL LS	01295	SN74LS148N
A6U2	1820-1197	9		1	IC GATE TTL LS NAND QUAD 2-INP	01295	SN74LS00N
A6U3	1820-1272	1		1	IC BFR TTL LS NOR QUAD 2-INP	01295	SN74LS33N
A6U4	1820-1112	8		2	IC FF TTL LS D-TYPE POS-EDGE-TRIG	01295	SN74LS74AN
A6U5	1826-0180	0		1	IC TIMER TTL MONO/ASTBL	01295	NE555P
A6U6	1820-1730	6		4	IC FF TTL LS D-TYPE POS-EDGE-TRIG COM	01295	SN74LS273N
A6U7	1820-1730	6			IC FF TTL LS D-TYPE POS-EDGE-TRIG COM	01295	SN74LS273N
A6U8	1820-1416	5		1	IC SCHMITT-TRIG TTL LS INV HEX 1-INP	01295	SN74LS14N
A6U9	1820-1437	0		1	IC MV TTL LS MONOSTBL DUAL	01698	SN74LS221N
A6U10	1820-1851	2			IC ENCDR TTL LS	01295	SN74LS148N
A6U11	1820-1917	1		1	IC BFR TTL LS LINE DRVR OCTL	01295	SN74LS240N
A6U12	1820-2024	3		1	IC DRVR TTL LS LINE DRVR OCTL	01295	SN74LS244N
A6U13	1820-2270	1		2	IC CNTR TTL LS BIN UP/DOWN SYNCHRO	34335	AM25LS2569DC
A6U14	1820-1144	6		1	IC GATE TTL LS NOR QUAD 2-INP	01295	SN74LS02N
A6U15	1820-1216	3		1	IC DCDR TTL LS 3-TO-8-LINE 3-INP	01295	SN74LS138N
A6U16	1820-1730	6			IC FF TTL LS D-TYPE POS-EDGE-TRIG COM	01295	SN74LS273N
A6U17	1820-1730	6			IC FF TTL LS D-TYPE POS-EDGE-TRIG COM	01295	SN74LS273N
A6U18	1820-2270	1			IC CNTR TTL LS BIN UP/DOWN SYNCHRO	34335	AM25LS2569DC
A6U19	1820-1112	8			IC FF TTL LS D-TYPE POS-EDGE-TRIG	01295	SN74LS74AN
A6U20	1820-1437	0		1	IC MV TTL LS MONOSTBL DUAL	01295	SN74LS221N
A6U21	1810-0280	8		2	NETWORK-RES 10-SIP10 0K OHM X 9	01121	210A103
A6U22	1810-0280	8			NETWORK-RES 10-SIP10 0K OHM X 9	01121	210A103
A6U23	1810-0206	8		1	NETWORK-RES 8-SIP10 0K OHM X 7	01121	208A103

Rear Panel Component-Level Information

Figure G-1 and Table G-1 provide a list of rear panel replaceable parts.

Rear Panel Component-Level Information

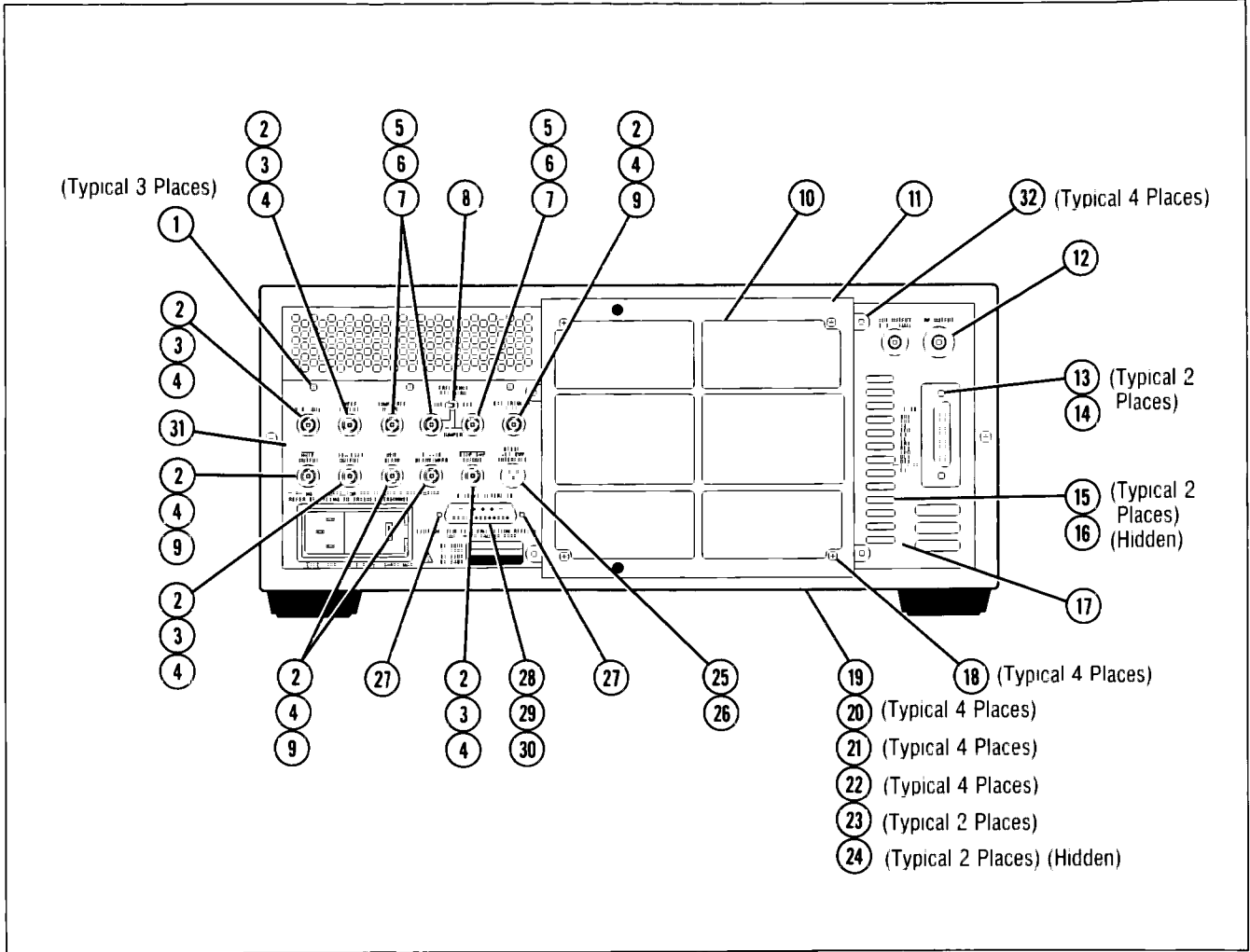

Figure G-1. Rear Panel Replaceable Parts

Rear Panel Component-Level Information

Table G-1. Rear Panel Replaceable Parts

Reference Designation	HP Part Number	C D	Qty	Description	Mfr Code	Mfr Part Number
				REAR PANEL		
1	2200-0105	4	99	SCREW-MACH 4-40 312-IN-LG PAN-HD-POZI	00000	ORDER BY DESCRIPTION
2	1250-0083	1	8	CONNECTOR-RF BNC FEM SGL-HOLE-FR 50-OHM	28480	1250-0083
3	0360-1632	0	4	TERMINAL-SLDR LUG LK-MTG FOR-#3/8-SCR	28480	0360-1632
4	2950-0001	8	8	NUT-HEX-B=-DBL-CHAM 3/8-32-THD 094-IN-THK	00000	ORDER BY DESCRIPTION
5	1250-0102	5	3	CONNECTOR-RF BNC FEM SGL-HOLE-FR 50-OHM	28480	1250-0102
6	2190-0068	5	3	WASHER-LK INTL T 1/2 IN 505-IN-ID	28480	2190-0068
7	2950-0054	1	3	NUT-HEX-DBL-CHAM 1/2-28-THD 125-IN-THK	00000	ORDER BY DESCRIPTION
8	3101-0163	5	1	SWITCH KIT	28480	3101-0163
9	2190-0016	3	4	WASHER-LK INTL T 3/8 IN 377-IN-ID	28480	2190-0016
10	08340-00018	3	1	FAN FILTER	28480	08340-00018
11	08340-00017	2	1	GRILL AIR	28480	08340-00017
12	6960-0009	1	1	HOLE PLUG 531-D-HOLE	28480	6960-0009
13	0380-0644	4	2	STANDOFF-HEX 400-IN-LG 6-32 THD	28480	0380-0644
14	2420-0002	6	2	NUT-HEX-DBL-CHAM 6-32-THD 109-IN-THK	28480	2420-0002
15	2360-0115	4	41	SCREW-MACH 6-32 312-IN-LG PAN-HD-POZI	00000	ORDER BY DESCRIPTION
16	08340-00056	9	1	DEFLECTOR-AIR	28480	08340-00056
17	08340-00011	6	1	PANEL-REAR (AUX OUTPUT)	28480	08340-00011
18	2360-0119	8	10	SCREW-MACH 6-32 438-IN-LG PAN-HD-POZI	00000	ORDER BY DESCRIPTION
19	08340-00016	1	1	BASE PLATE-FAN	28480	08340-00016
20	1520-0230	3	4	SHOCK MOUNT	28480	1520-0230
21	85660-20092	4	4	SNUBBER SHOCK MOUNT	28480	85660-20092
22	2360-0196	1	4	SCREW-MACH 6-32 375-IN-LG 100 DEG	28480	2360-0196
23	2190-0009	4	2	WASHER-LK INT T NO 8 168-IN-ID	28480	2190-0009
24	2510-0051	6	2	SCREW-MACH 8-32 625-IN-LG PAN-HD-POZI	28480	2510-0051
25	1251-6781	0	1	CONNECTOR RECEPTACLE 3 MALE CONTACT	28480	1251-6781
26	2190-0104	0	1	WASHER-LK INTL T 7/16 IN 439-IN-ID	28480	2190-0104
27	1251-2943	7	2	CONNECTOR-RACK & PANEL LOCK	28480	1251-2942
28	1251-0064	0	1	CONNECTOR 25-PIN F D SERIES	28480	1251-0064
29	1251-3653	9	26	CONNECTOR CONTACT FEMALE 025	28480	1251-3653
30	1251-7374	9	1	CONNECTOR HOUSING-28 FEMALE 2R	28480	1251-7374
31	08340-00010	5	1	REAR PANEL	28480	08340-00010
32	2360-0115	4		SCREW-MACH 6-32 312-IN-LG PAN-HD-POZI	00000	ORDER BY DESCRIPTION

RF Section Component-Level Service H

CONTENTS

A20 RF SECTION FILTER

CIRCUIT DESCRIPTION	A20-1
Assembly Purpose	A20-1
The Two Parts of the Filter	A20-1
A62J19 to A20J1 Pin I/O	A20-2
A20 RF Section Filter Component Location Diagram	A20-4
A20 RF Section Filter Schematic Diagram	A20-5
A20 RF Section Filter Replaceable Parts	A20-7

A21 PULSE MODULATOR

CIRCUIT DESCRIPTION	A21-1
Assembly Purpose	A21-1
Input Buffer and Control Logic (Block A)	A21-1
Slow Rise Time Pulse Driver (Block B)	A21-1
Modulator Driver (Block C)	A21-2
Integrator Timing (Block D)	A21-2
ADC Timing (Block E)	A21-2
Sample/Hold Timing (Block F)	A21-3
A21 Pulse Modulator Driver P1 Pin I/O	A21-4
A21 Pulse Modulator Component Location Diagram	A21-6
A21 Pulse Modulator Schematic Diagram	A21-7
A21 Pulse Modulator Replaceable Parts	A21-9

A24 ATTENUATOR DRIVER/STEP RECOVER DIODE (SRD) BIAS

CIRCUIT DESCRIPTION	A24-1
Assembly Purpose	A24-1
Frequency Ramp Generator (Block A)	A24-1
Modulator Voltage Clamp (Block B)	A24-1
Band Decoder (Block C)	A24-2
SRD Bias Adjustments (Block D)	A24-2
Exponential Generator (Block E)	A24-2
SRD Bias Amplifier (Block F)	A24-2
Pin Diode Bias (Block G)	A24-3
Read Status Output Buffer (Block H)	A24-3
Attenuator Control Latch (Block I)	A24-3
Attenuator Coil Drivers (Block J)	A24-3
Switched YIG-Tuned Multiplier (SYTM) Heater Control (Block K)	A24-4
Power Supply (Block L)	A24-4
A24 Attenuator Driver/SRD Bias P1 Pin I/O	A24-5
A24 Attenuator Driver/SRD Bias Component Location Diagram	A24-6
A24 Attenuator Driver/SRD Bias Schematic Diagram	A24-7
A24 Attenuator Driver/SRD Bias Replaceable Parts	A24-9

CONTENTS (Cont'd)

A25 ALC DETECTOR

CIRCUIT DESCRIPTION	A25-1
Assembly Purpose	A25-1
Internal Detector Log Converter (Block A)	A25-1
X5 Amplifier (Block B)	A25-2
Sample/Hold (Block C)	A25-2
Level Meter Amplifier (Block D)	A25-2
System Leveling Relay Driver (Block E)	A25-2
Function Switches and External Detector Frequency Compensation (Block F)	A25-3
Level Reference Temperature Compensation (Block G)	A25-3
External Log Converter (Block H)	A25-4
Power Supply (Block I)	A25-4
A25 ALC Detector Pin I/O	A25-5
A25 ALC Detector Component Location Diagram	A25-8
A25 ALC Detector Schematic Diagram	A25-9
A25 ALC Detector Replaceable Parts	A25-11

A26 LINEAR MODULATOR

CIRCUIT DESCRIPTION	A26-1
Assembly Purpose	A26-1
AM Log Converter (Block A)	A26-1
ALC Loop Integrator (Block B)	A26-1
Overmodulation/Unleveled Detectors (Block C)	A26-2
ALC Modulator Switch (Block D)	A26-2
ALC Loop Function Switch Drivers (Block E)	A26-3
Band Switch Drivers (Block F)	A26-3
ALC Modulator Driver (Block G)	A26-3
Power Supply (Block H)	A26-3
A26 Linear Modulator Pin I/O	A26-5
A26 Linear Modulator Component Location Diagram	A26-8
A26 Linear Modulator Schematic Diagram	A26-9
A26 Linear Modulator Replaceable Parts	A26-11

A27 LEVEL CONTROL

CIRCUIT DESCRIPTION	A27-1
Assembly Purpose	A27-1
Band Switch Control (Block A)	A27-1
Address Decoding (Block B)	A27-1
20 GHz Breakpoint Slope Compensation (Block C)	A27-1
9 GHz Breakpoint Slope Compensation (Block D)	A27-1
Attenuator Slope Compensation (Block E)	A27-2
Compensation Summing Amplifier (Block F)	A27-2
Cable Slope Compensation (Block G)	A27-2
ALC Reference Generator (Block H)	A27-2
Power Sweep Generator (Block I)	A27-3
Reference Level Summing Amplifier (Block J)	A27-3
Fail Test LED (Block K)	A27-3
ADC Control Latch (Block L)	A27-3

CONTENTS (Cont'd)

A27 LEVEL CONTROL (CONT'D)

ADC Clock/Control (Block M)	A27-3
ADC Input Multiplexer (Block N)	A27-4
Test ADC (Block O)	A27-4
ADC Window Comparator (Block P)	A27-5
Conversion Complete Timer/SRQ Latch (Block Q)	A27-5
Status Buffer (Block R)	A27-6
Power Supplies (Block S)	A27-6
A27 Control P1 Pin I/O	A27-8
A27 Level Control Component Location Diagram	A27-10
A27 Level Control Schematic Diagram	A27-11
A27 Level Control Replaceable Parts	A27-15

A28 SYTM DRIVER

CIRCUIT DESCRIPTION	A28-1
Assembly Purpose	A28-1
Offset Compensation (Block A)	A28-1
Delay Compensation (Block B)	A28-2
Slope Compensation (Block C)	A28-2
Compensation Summing Amplifier (Block D)	A28-2
Voltage Reference (Block E)	A28-3
Power Supplies (Block F)	A28-3
Programmable Scalar (Block G)	A28-3
-0.25V/GHz (Block H)	A28-3
Digital Control (Block I)	A28-4
+1.0/+0.5 V/GHz (Block J)	A28-4
Current Driver (Block K)	A28-5
Kick Pulse (Block L)	A28-5
A28 SYTM Driver P1 Pin I/O	A28-6
A28 SYTM Driver Component Location Diagram	A28-8
A28 SYTM Driver Schematic Diagram	A28-9
A28 SYTM Driver Replaceable Parts	A28-13

A20 RF Section Filter Circuit Description

ASSEMBLY PURPOSE

The A20 RF section filter provides:

- Filtered power supplies to the low band power amplifier
- Filtered power supplies to the high band power amplifier
- Low band power amplifier control switch

THE TWO PARTS OF THE FILTER

The A20 RF section filter consists of two major sections:

- The power amplifier supply filters
- The low band amplifier switch

The Power Amplifier Supply Filters

When operating at full power, the high band amplifier requires a substantial amount of current from the +5.2V and -10V power supplies. During pulsed operation, the input signal to the power amplifier is turned off and on at the input pulse rate, which causes large current surges in the supply lines. If the supply lines were unfiltered, the voltages would fluctuate at the input pulse rate. Voltage line fluctuations could affect the YO phase lock circuitry and the main YO coil driver circuitry, causing FM sidebands (at the pulse frequency) on the output carrier. The sidebands would not be noticeable in the (pulsed) RF output, but would be apparent (50 to 60 dBc) in the rear panel YO AUX output. To minimize voltage fluctuations, the +5.2V and the -10V supplies to the high band amplifier each have a two-stage LC filter, and the +20V supply to the low band amplifier is filtered through a single stage filter.

Low Band Amplifier Switch

To reduce any low band noise feedthrough at the RF output, the low band amplifier switch turns off the -10V supply to the low band amplifier when the instrument is not operating in low band. The switch is digitally controlled by the A27 level control assembly, through two common emitter control transistors.

A20 RF Section Filter Component-Level Troubleshooting

Table A20-1. A62J19 to A20J1 Pin I/O

A62J19 Pin	Mnemonic	A62W31P2 Pin	A62W31P3 Pin	A16A1J1 Pin	A20J1 Pin	Levels
1	GND PLANE	1	1	1	1	0V
2	+20V	2	NOT USED	NOT USED	2	+20V
3	+5.2V	3	3	3	3	+5.2V
4	-5.2V	4	4	4	4	-5.2V
5	-10V	5	NOT USED	NOT USED	5	-10V
6	-40V/-40V SENSE (-)	6	NOT USED	NOT USED	6	-40V
7	LHET	7	NOT USED	NOT USED	7	TTL (LOW TRUE)
8	LHET	8	NOT USED	NOT USED	8	TTL (LOW TRUE)
9	GND PLANE	9	9	9	9	0V
10	+20V	10	NOT USED	NOT USED	10	+20V
11	+5.2V	11	11	11	11	+5.2V
12	-5.2V	12	12	12	12	-5.2V
13	-10V	13	NOT USED	NOT USED	13	-10V
14	-25V/GHZ	NOT USED	NOT USED	NOT USED	NOT USED	
15	LHIBND	NOT USED	15	15	NOT USED	
16	HULH	16	NOT USED	NOT USED	16	TTL (HIGH TRUE)

Note. Refer to RF Section Schematic Diagram and A62 motherboard wiring list for signal source and destination information.

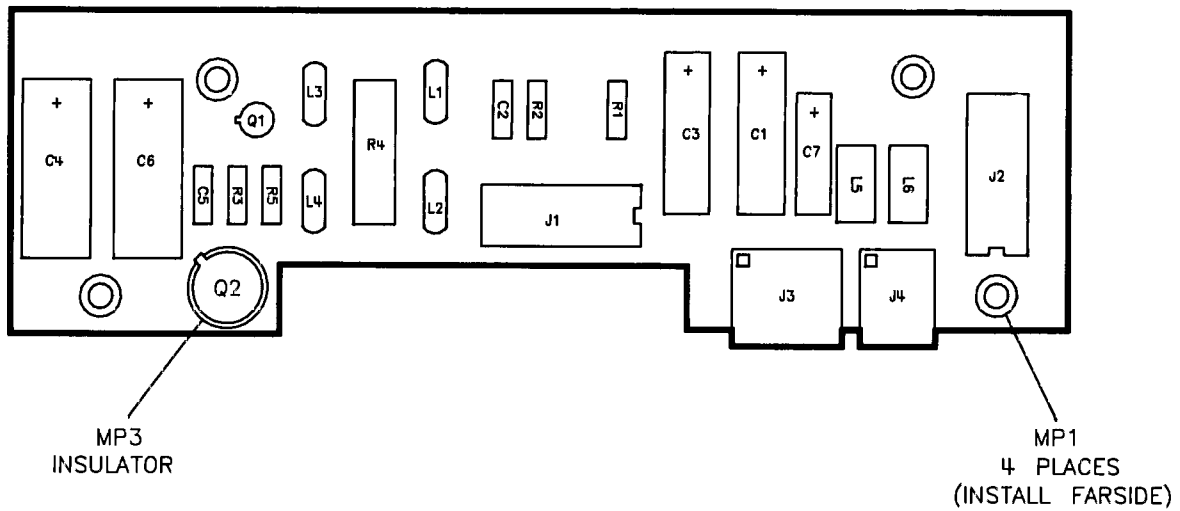

HP Part Number: 08340-60261

Figure A20-1. A20 RF Section Filter Component Location Diagram

NOTES:

1. RESISTANCE VALUES ARE IN OHMS, CAPACITANCE IN MICROFARADS, AND INDUCTANCE IN MICROHENRIES UNLESS OTHERWISE NOTED.

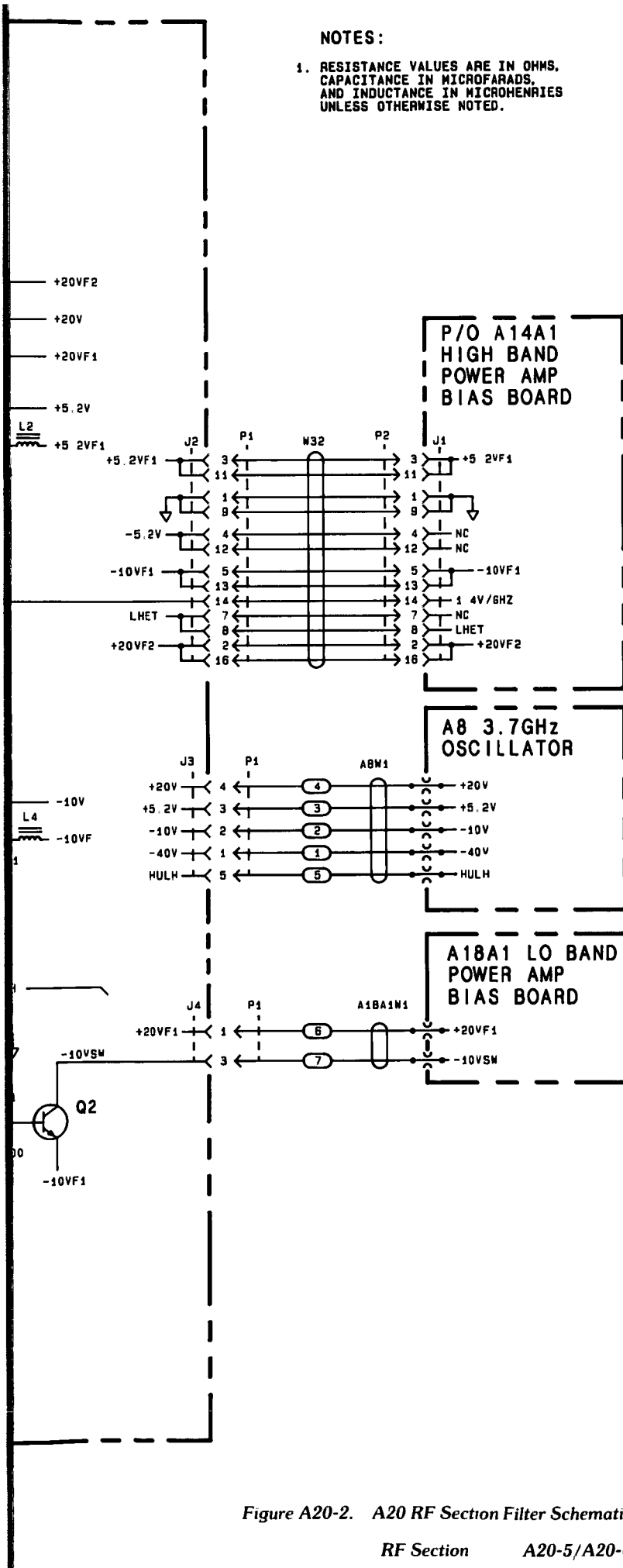

Figure A20-2. A20 RF Section Filter Schematic
RF Section A20-5/A20-6

A20 RF Section Filter Component-Level Troubleshooting

Table A20-2. A20 RF Section Filter Replaceable Parts

Reference Designation	HP Part Number	C D	Qty	Description	Mfr Code	Mfr Part Number
A20	08340-60261	4	1	RF SECTION FILTER ASSEMBLY	28480	08340-60261
A20C1	0180-2614	8	2	CAPACITOR-FXD 100UF ± 10% 30VDC TA	56289	150D107X9030S2
A20C2	0160-4835	7	2	CAPACITOR-FXD 1UF ± 10% 50VDC CER	28480	0160-4835
A20C3	0180-2614	8	2	CAPACITOR-FXD 100UF ± 10% 30VDC TA	56289	150D107X9030S2
A20C4	0180-0094	4	2	CAPACITOR-FXD 100UF ± 75-10% 25VDC AL	56289	30D107G025DD2
A20C5	0160-4835	7	2	CAPACITOR-FXD 1UF ± 10% 50VDC CER	28480	0160-4835
A20C6	0180-0094	4	2	CAPACITOR-FXD 100UF ± 75-10% 25VDC AL	56289	30D107G025DD2
A20C7	0180-0116	1	1	CAPACITOR-FXD 6 8UF ± 10% 35VDC TA	56289	150D685X9035B2
A20J1	1200-0482	9	2	SOCKET-IC 16-CONT DIP-SLDR	28480	1200-0482
A20J2	1200-0482	9	2	SOCKET-IC 16-CONT DIP-SLDR	28480	1200-0482
A20J3	1251-6794	5	1	CONNECTOR HEADER 5 M IR	28480	1251-6794
A20J4	1251-6795	6	1	CONNECTOR HEADER 3 M IR	28480	1251-6795
A20L1	08340-80001	2	4	COIL-TOROID	28480	08340-80001
A20L2	08340-80001	2	4	COIL-TOROID	28480	08340-80001
A20L3	08340-80001	2	4	COIL-TOROID	28480	08340-80001
A20L4	08340-80001	2	4	COIL-TOROID	28480	08340-80001
A20L5	9100-0539	3	2	INDUCTOR 10 μH	28480	9100-0539
A20L6	9100-0539	3	2	INDUCTOR 10 μH	28480	9100-0539
A20MP1	0380-0773	0	4	SPACER-RVT-ON 5-IN-LG 152-IN-ID	00000	ORDER BY DESCRIPTION
A20Q1	1853-0281	9	1	TRANSISTOR PNP 2N2907A SI TO-18 PD=400MW	04713	2N2907A
A20Q2	1854-0361	8	1	TRANSISTOR NPN 2N4239 SI TO-5 PD=6W	04713	2N4239
A20R1	0757-0442	9	1	RESISTOR 10K 1% 125W F TC=0 ± 100	24546	C4-1/8-T0-1002-F
A20R2	0757-1094	9	1	RESISTOR 1 47k 1% 125W F TC=0 ± 100	24546	C4-1/8-T0-1471-F
A20R3	0757-0290	5	1	RESISTOR 6 19k 1% 125W F TC=0 ± 100	19701	MF4C1/8-T0-6191-F
A20R4	0757-1090	5	1	RESISTOR 261 1% 5W F TC=0 ± 100	28480	0757-1090
A20R5	0757-0280	3	1	RESISTOR 1K 1% 125W F TC=0 ± 100	24546	C4-1/8-T0-1001-F

A21 Pulse Modulator Circuit Description

ASSEMBLY PURPOSE

The A21 pulse modulator assembly controls the synthesizer pulse modulation functions. The main control signal is the front panel BNC, PULSE MODULATION INPUT. The pulse modulator drives the PIN switch RF modulators in the A9 (low band) or A16 (high band) microcircuits.

Timing circuits send control signals to key elements of the ALC loop to coordinate the leveling function with the pulse modulation.

INPUT BUFFER AND CONTROL LOGIC (BLOCK A)

PULSE MODULATION (TTL compatible) is buffered as it enters this block. Two control lines gate the pulse input.

- HPLSEN (high pulse enable) gates the buffered pulses.
- HRFON (high RF on) overrides the pulse input, turning the RF off.

An eight-bit latch provides control lines and decoding signals for the rise time pulse driver and modulator driver circuitry. Control lines are also provided for the A25 ALC detector assembly.

Input Impedance

Input resistor R5 establishes the input impedance. If necessary, change the resistor value to 51 1Ω to provide a 50 Ω impedance. If you do this, however, be aware that an open-circuit input is no longer pulled high. This means that if pulse modulation is activated with an open-circuit input, the RF turns off.

Bias Sample/Hold Timing

This signal controls the sample/hold gate on the A22 assembly (applicable on the HP 8340A Option H02 only). It is adjusted to close the gate (sample) when the RF pulse is on and open the gate (hold) when the RF is off. The signal keeps the SRD bias constant when the RF is off.

SLOW RISE TIME PULSE DRIVER (BLOCK B)

Fast rise time pulse modulation produces a broad spectrum of harmonics that can result in measurement errors. To minimize harmonics, a pulse modulation mode is available that provides pulses of approximately 2 μs rise and fall times.

When you activate the slow pulse mode ([SHIFT] [PULSE]), the input pulse is routed through block B to driver circuitry in the modulator driver (all pulses are routed to block C, but only slow pulse signals are routed through block B). The slow rise time driver amplifier, controls the driver circuitry. Wave shaping of the control signal provides a slow transition through the modulator turn-on region. To assure that the RF output has reached the proper level, the sample/hold timing is delayed until the pulse has risen.

Low and high band symmetry adjustments independently adjust the output for symmetrical RF pulse outputs.

MODULATOR DRIVER (BLOCK C)

The modulator driver provides the current and voltage bias for the RF pulse modulators. A differential current switch controls the bias for two transistor drivers. When the input (LPLSON) is high (RF off), the PIN diode modulator is biased on, turning the RF off. When the input is low, the PIN diode modulator is back-biased, turning the RF on.

Transistor driver output capacitors provide AC coupling for the transition current spikes from the modulators back to the A21 assembly

Two FETs form an output multiplexer for low or high band modulator selection. Digital input signals (BAND0 and HIBAND) determine the modulator selection. Input control line LHET (block A) controls these digital lines.

INTEGRATOR TIMING (BLOCK D)

Block D controls the timing used to gate the ALC loop integrator input (A26). This ensures that the integrator responds to RF power level error signals only when the detected RF level is on and stable.

When the input (LOL) goes low (RF on), the output of the NAND gate is forced high. The low-pass filter following the NAND gate delays the transition by 1 μ s. When the output goes high, the integrator is enabled. When the input goes high (RF off), the NAND gate output goes low to put the integrator circuits on hold.

When the input (LOL) goes low, it triggers timers that output low pulses to the output NAND gate. This determines the minimum time the output is high for each RF pulse. The pulse time period depends on the ALC loop bandwidth and is controlled by timing control signals from the control logic (block A). Internal leveling sample time is 1 or 10 μ s, depending on the bandwidth. External leveling sample time is 0.2 μ s.

ADC TIMING (BLOCK E)

The ADC timing lets the A27 assembly monitor the detected power level when either the RF is on, or up to 1.8 ms after the RF is turned off. This prevents the POWER dBm display from showing an invalid power level if the RF is turned off for over 1.8 ms (ALC sample/hold droop).

When the input is low (RF on), the output is forced high to enable the clock control circuitry on the A27 assembly. When the input goes high, the one-shot timer outputs a 1.8 ms low pulse, holding the clock control enabled. If the RF does not turn on again within 1.8 ms, the timer output goes high, forcing the output to disable the clock control.

SAMPLE/HOLD TIMING (BLOCK F)

Block F controls the timing of the sample/hold gate in detector circuits on the A25 assembly during pulse modulation. The key timing element is C19. The time delay constant is independent and adjustable for both RF on and RF off. The voltage on C19 is detected by a schmitt trigger whose square wave output is delayed by the pulse from the control logic section.

ON DELAY adjustments (for both system and internal leveling) adjust the discharge time, and OFF DELAY adjusts the charging time of C19.

If C19 is not fully discharged before the timing input goes high, the rising edge briefly turns on a discharge transistor circuit to fully discharge C19. This ensures that the OFF DELAY is independent of the pulse width.

A21 Pulse Modulator Component-Level Troubleshooting

A21 Pin I/O

Pin	Mnemonic	Levels	Source	Destination
1 19	HADCEN BIAS S/H PULSE	TTL (HIGH TRUE) TTL	D A	XA27P1-8 XA22P1-8
2 20	LMODHLD	TTL	E	XA26P1-1
3 21	DET S/H + DET S/H -	+4.5V/+3.5V +3.5V/+4.5V	F F	XA25P1-2 XA25P1-24
4 22 5 23	+20V +20V +5.2V +5.2V	+20V +20V +5.2V +5.2V	XA52P1-16, 40 XA52P1-16, 40 XA52P1-17, 18, 41, 42 XA52P1-17, 18, 41, 42	*G *G *G *G
6 24	HLBW	TTL (HIGH TRUE)	XA26P1-33	XA26P1-33
7 25	-10V -10V	-10V -10V	XA53P1-12, 13, 31, 32 XA53P1-12, 13, 31, 32	*G *G
8 26	GND GND	0V 0V	A62 STAR GND A62 STAR GND	*G *G
9 27	HPLSEN HRFON	TTL (HIGH TRUE) TTL (HIGH TRUE)	XA26P1-2 XA57P1-105	*A *A C
10 28				
11 29	LHET	TTL (LOW TRUE)	XA27P1-20	*C
12 30				
13 31				
14 32				
15 33				
16 34	LOPMOD DRV	CURRENT SOURCE	C	A62J10-SMC CENTER
17 35	PLS IN RTN PMOD RTN	0V PV	* B	*A *A
18 36	PLS IN HIPMOD DRV	TTL CURRENT TO PIN DIODE	A62J26-SMC CENTER C	A A62J25-SMC CENTER

A single letter in the source or destination column refers to a function block on this assembly schematic.

An asterisk (*) denotes multiple sources or destinations; refer to the A62 motherboard wiring list for a complete representation of signal sources and destinations.

A21 Pulse Modulator Component-Level Troubleshooting

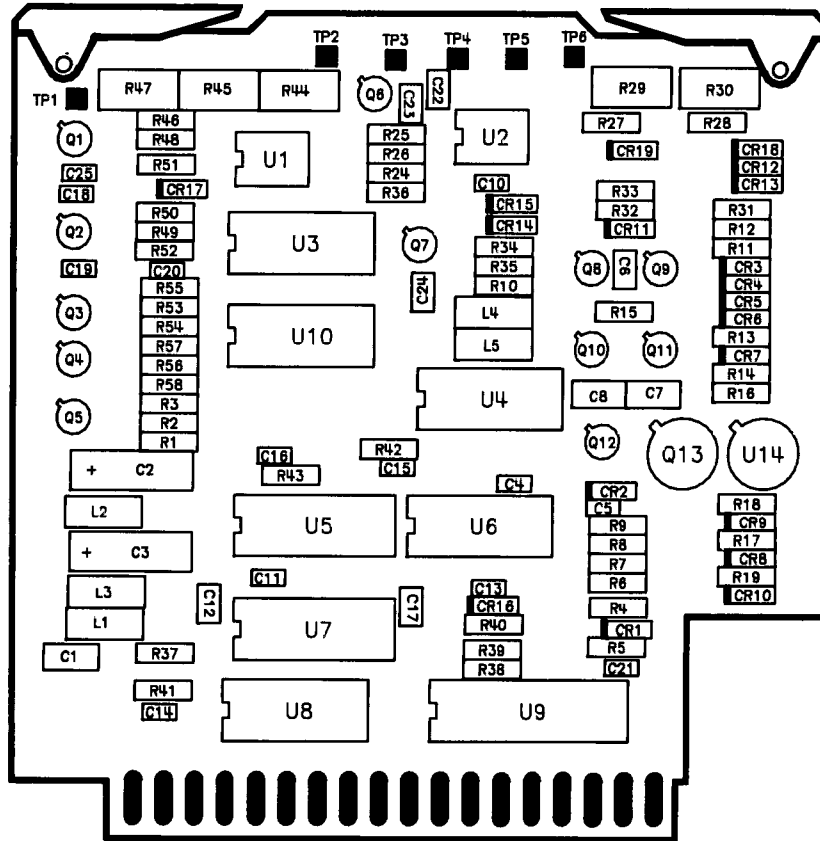

HP Part Number: 08340-60290

Figure A21-1. A21 Pulse Modulator Component Location Diagram

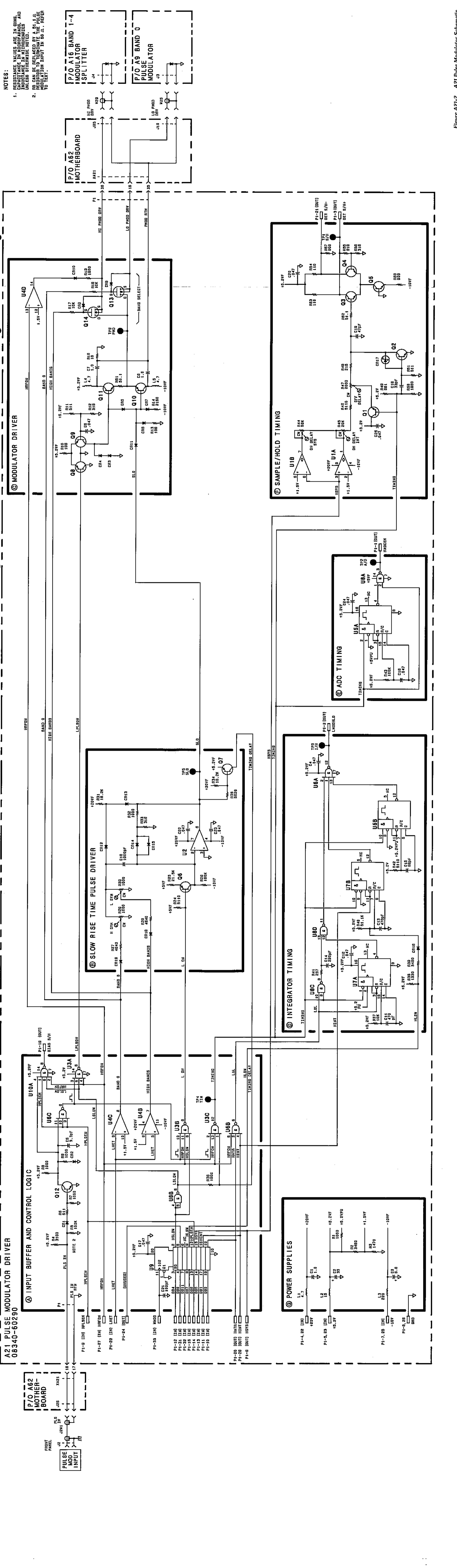

NOTES:

- RESISTANCE VALUES ARE IN OHMS, CAPACITANCE IN MICROFARADS, AND INDUCTANCE IN MICROHENRIES, UNLESS OTHERWISE NOTED.
- RES CAN BE REPLACED BY A 1/2 WATT MODULATION INPUT IN 50 Ω, REFER TO TEXT.

Figure A21-2. A21 Pulse Modulator Schematic
RF Section A21-7/A21-8

A21 Pulse Modulator Component-Level Troubleshooting

Table A21-2. A21 Pulse Modulator Replaceable Parts

Reference Designation	HP Part Number	C D	Qty	Description	Mfr Code	Mfr Part Number
A21	08340-60290	9	1	PULSE MODULATOR DRIVER	28480	08340-60290
A21C1	0160-4535	4	3	CAPACITOR-FXD 1UF ± 5% 50VDC CER	28480	0160-4535
A21C2	0180-0229	7	1	CAPACITOR-FXD 33UF ± 20% 10VDC TA	28480	0180-0229
A21C3	0180-0116	1	1	CAPACITOR-FXD 6 8UF ± 20% 35VDC TA	28480	0180-0116
A21C4	0160-0575	4	10	CAPACITOR-FXD 047UF ± 20% 50VDC CER	28480	0160-0575
A21C5	0160-4797	0	1	CAPACITOR-FXD 3 3PF ± 20% 100VDC CER	28480	0160-4797
A21C6	0160-0575	4		CAPACITOR-FXD 047UF ± 20% 50VDC CER	28480	0160-0575
A21C7	0160-4535	4		CAPACITOR-FXD 1UF ± 5% 50VDC CER	28480	0160-4535
A21C8	0160-4535	4		CAPACITOR-FXD 1UF ± 5% 50VDC CER	28480	0160-4535
A21C9				NOT ASSIGNED		
A21C10	0160-4822	2	1	CAPACITOR-FXD 1000PF ± 5% 100VDC CER	28480	0160-4822
A21C11	0160-4808	4	2	CAPACITOR-FXD 470PF ± 5% 100VDC CER	28480	0160-4808
A21C12	0160-0575	4		CAPACITOR-FXD 047UF ± 20% 50VDC CER	28480	0160-0575
A21C13	0160-4808	4		CAPACITOR-FXD 470PF ± 5% 100VDC CER	28480	0160-4808
A21C14	0160-4812	0	1	CAPACITOR-FXD 220PF ± 5% 100VDC CER	28480	0160-4812
A21C15	0160-4803	9	1	CAPACITOR-FXD 68PF ± 5% 100VDC CER	28480	0160-4803
A21C16	0160-0575	4		CAPACITOR-FXD 047UF ± 20% 50VDC CER	28480	0160-0575
A21C17	0160-0575	4		CAPACITOR-FXD 047UF ± 20% 50VDC CER	28480	0160-0575
A21C18	0160-4807	3	1	CAPACITOR-FXD 33PF 5% 100V CER	28480	0160-4807
A21C19	0160-4805	1	1	CAPACITOR-FXD 47PF 5% 100V CER	28480	0160-4805
A21C20	0160-0575	4		CAPACITOR-FXD 047UF ± 20% 50VDC CER	28480	0160-0575
A21C21	0160-4801	7	1	CAPACITOR-FXD 047UF 20% 50V CER	28480	0160-4801
A21C22	0160-0575	4		CAPACITOR-FXD 047UF ± 20% 50VDC CER	28480	0160-0575
A21C23	0160-0575	4		CAPACITOR-FXD 047UF ± 20% 50VDC CER	28480	0160-0575
A21C24	0160-0575	4		CAPACITOR-FXD 047UF ± 20% 50VDC CER	28480	0160-0575
A21C25	0160-0575	4		CAPACITOR-FXD 047UF ± 20% 50VDC CER	28480	0160-0575
A21CR1	1901-0050	3	9	DIODE-SWITCHING 80V 200MA 2NS DO-35	28480	1901-0050
A21CR2	1901-0050	3		DIODE-SWITCHING 80V 200MA 2NS DO-35	28480	1901-0050
A21CR3	1901-0050	3		DIODE-SWITCHING 80V 200MA 2NS DO-35	28480	1901-0050
A21CR4	1901-0050	3		DIODE-SWITCHING 80V 200MA 2NS DO-35	28480	1901-0050
A21CR5	1901-0050	3		DIODE-SWITCHING 80V 200MA 2NS DO-35	28480	1901-0050
A21CR6	1901-0050	3		DIODE-SWITCHING 80V 200MA 2NS DO-35	28480	1901-0050
A21CR7	1901-0050	3		DIODE-SWITCHING 80V 200MA 2NS DO-35	28480	1901-0050
A21CR8	1901-0050	3		DIODE-SWITCHING 80V 200MA 2NS DO-35	28480	1901-0050
A21CR9	1901-0050	3		DIODE-SWITCHING 80V 200MA 2NS DO-35	28480	1901-0050
A21CR10	1901-0050	3		DIODE-SWITCHING 80V 200MA 2NS DO-35	28480	1901-0050
A21CR11	1901-0050	3		DIODE-SWITCHING 80V 200MA 2NS DO-35	28480	1901-0050
A21CR12	1901-0050	3		DIODE-SWITCHING 80V 200MA 2NS DO-35	28480	1901-0050
A21CR13	1901-0050	3		DIODE-SWITCHING 80V 200MA 2NS DO-35	28480	1901-0050
A21CR14	1901-0050	3		DIODE-SWITCHING 80V 200MA 2NS DO-35	28480	1901-0050
A21CR15	1901-0050	3		DIODE-SWITCHING 80V 200MA 2NS DO-35	28480	1901-0050
A21CR16	1901-0050	3		DIODE-SWITCHING 80V 200MA 2NS DO-35	28480	1901-0050
A21CR17	1901-0539	3	1	DIODE-SM SIG SCHOTTKY	28480	1901-0539
A21CR18	1901-0050	3		DIODE-SWITCHING 80V 200MA 2NS DO-35	28480	1901-0050
A21CR19	1901-0050	3		DIODE-SWITCHING 80V 200MA 2NS DO-35	28480	1901-0050
A21L1	9100-3562	8	3	COIL-4 7 UH 5%	28480	9100-3562
A21L2	9100-3912	2	1	INDUCTOR RF-CH-MLD 220UH 5% 166DX 385LG	28480	9140-0129
A21L3	9140-0129	1	1	INDUCTOR RF-CH-MLD 220UH 5% 166DX 385LG	28480	9140-0129
A21L4	9100-3562	8		COIL-4 7 UH 5%	28480	9100-3562
A21L5	9100-3562	8		COIL-4 7 UH 5%	28480	9100-3562
A21MP1	4040-0750	7	1	EXTR-PC BD RED POLYC 062-BD-THKNS	28480	4040-0750
A21MP2	4040-0749	4	1	EXTR-PC BD BRN POLYC 062-BD-THKNS	28480	4040-0749
A21MP3, 4	1480-0073	6	2	PIN-ROLL 062-IN-DIA 25-IN-LG BE-CU	28480	1480-0073
A21Q1	1854-0809	9	7	TRANSISTOR NPN 2N2369A SI TO-18 PD=360MW	28480	1854-0809
A21Q2	1854-0809	9		TRANSISTOR NPN 2N2369A SI TO-18 PD=360MW	28480	1854-0809
A21Q3	1854-0809	9		TRANSISTOR NPN 2N2369A SI TO-18 PD=360MW	28480	1854-0809
A21Q4	1854-0809	9		TRANSISTOR NPN 2N2369A SI TO-18 PD=360MW	28480	1854-0809
A21Q5	1854-0809	9		TRANSISTOR NPN 2N2369A SI TO-18 PD=360MW	28480	1854-0809
A21Q6	1853-0405	9	3	TRANSISTOR PNP 2N4209A SI TO-18 PD=360MW	28480	1854-0405
A21Q7	1853-0405	9		TRANSISTOR PNP 2N4209A SI TO-18 PD=360MW	28480	1854-0405
A21Q8	1853-0018	0	2	TRANSISTOR PNP SI 2N4260	28480	1853-0018
A21Q9	1853-0018	0		TRANSISTOR PNP SI 2N4260	28480	1853-0018
A21Q10	1853-0405	9		TRANSISTOR PNP 2N4209A SI TO-18 PD=360MW	28480	1854-0405
A21Q11	1854-0809	9		TRANSISTOR NPN 2N2369A SI TO-18 PD=360MW	28480	1854-0809
A21Q12	1854-0809	9		TRANSISTOR NPN 2N2369A SI TO-18 PD=360MW	28480	1854-0809
A21Q13	1855-0251	7	2	TRANSISTOR NPN 2N6659	28480	1855-0251
A21Q14	1855-0251	7		TRANSISTOR NPN 2N6659	28480	1855-0251
A21R1	0757-0280	3	6	RESISTOR 1K 1% 125W F TC=0±100	24546	C4-1/8-T0-1001-F
A21R2	0698-3152	8	2	RESISTOR 3 48K 1% 125W F TC=0±100	24546	C4-1/8-T0-3481-F
A21R3	0757-1094	9	1	RESISTOR 1 47K 1% 125W F TC=0±100	24546	C4-1/8-T0-1471-F
A21R4	0757-0279	0	1	RESISTOR 3 16K 1% 125W F TC=0±100	24546	C4-1/8-T0-3161-F
A21R5	0757-0465	6	3	RESISTOR 100K 1% 125W F TC=0±100	24546	C4-1/8-T0-1003-F

A21 Pulse Modulator Component-Level Troubleshooting

Table A21-2. A21 Pulse Modulator Replaceable Parts

Reference Designation	HP Part Number	C D	Qty	Description	Mfr Code	Mfr Part Number
A21R6	0575-0416	7	3	RESISTOR 511 1% 125W F TC=0±100	24546	C4-1/8-T0-511R-F
A21R7	0757-0280	3		RESISTOR 1K 1% 125W F TC=0±100	24546	C4-1/8-T0-1001-F
A21R8	0757-0280	3		RESISTOR 1K 1% 125W F TC=0±100	24546	C4-1/8-T0-1001-F
A21R9	0757-0280	3		RESISTOR 1K 1% 125W F TC=0±100	24546	C4-1/8-T0-1001-F
A21R10	0698-3440	7	2	RESISTOR 196 1% 125W F TC=0±100	24546	C4-1/8-T0-196R-F
A21R11	0575-0416	7		RESISTOR 511 1% 125W F TC=0±100	24546	C4-1/8-T0-511R-F
A21R12	0698-3444	4	3	RESISTOR 316 1% 125W F TC=0±100	24546	C4-1/8-T0-316R-F
A21R13	0698-3440	7		RESISTOR 196 1% 125W F TC=0±100	24546	C4-1/8-T0-196R-F
A21R14	0698-0084	9	1	RESISTOR 215K 1% 125W F TC=0±100	24546	C4-1/8-T0-2151-F
A21R15	0757-0394	0	2	RESISTOR 51 1K 1% 125W F TC=0±100	24546	C4-1/8-T0-51R1-F
A21R16	0757-0346	2	1	RESISTOR 10 1% 125W F TC=0±100	24546	C4-1/8-T0-10R0-F
A21R17	0757-0442	9	3	RESISTOR 10K 1% 125W F TC=0±100	24546	C4-1/8-T0-1002-F
A21R18	0757-0442	9		RESISTOR 10K 1% 125W F TC=0±100	24546	C4-1/8-T0-1002-F
A21R19	0698-0083	8	2	RESISTOR 196K 1% 125W F TC=0±100	24546	C4-1/8-T0-1961-F
A21R20				NOT ASSIGNED		
A21R21				NOT ASSIGNED		
A21R22				NOT ASSIGNED		
A21R23				NOT ASSIGNED		
A21R24	0757-0438	3	3	RESISTOR 5 11K 1% 125W F TC=0±100	24546	C4-1/8-T0-5111-F
A21R25	0757-0199	3	1	RESISTOR 21 5K 1% 125W F TC=0±100	24546	C4-1/8-T0-2152-F
A21R26	0757-0465	6		RESISTOR 100K 1% 125W F TC=0±100	24546	C4-1/8-T0-1003-F
A21R27	0698-3155	5	2	RESISTOR 4 64K 1% 125W F TC=0±100	24546	C4-1/8-T0-4641-F
A21R28	0698-3155	5		RESISTOR 4 64K 1% 125W F TC=0±100	24546	C4-1/8-T0-4641-F
A21R29	2100-3352	7	2	RESISTOR-TRMR 1K 10% C SIDE-ADJ 1-TRN	28480	2100-3352
A21R30	2100-3352	7		RESISTOR-TRMR 1K 10% C SIDE-ADJ 1-TRN	28480	2100-3352
A21R31	0757-0447	4	2	RESISTOR 11 2K 1% 125W F TC=0±100	24546	C4-1/8-T0-1622-F
A21R32	0757-0280	3		RESISTOR 1K 1% 125W F TC=0±100	24546	C4-1/8-T0-1001-F
A21R33	0698-3444	4		RESISTOR 316 1% 125W F TC=0±100	24546	C4-1/8-T0-316R-F
A21R34	0757-0447	4		RESISTOR 11 2K 1% 125W F TC=0±100	24546	C4-1/8-T0-1622-F
A21R35	0757-0200	7	1	RESISTOR 5 62K 1% 125W F TC=0±100	14546	C4-1/8-T0-5621-F
A21R36	0757-0280	3		RESISTOR 1K 1% 125W F TC=0±100	24546	C4-1/8-T0-1001-F
A21R37	0757-0442	9		RESISTOR 10K 1% 125W F TC=0±100	24546	C4-1/8-T0-1002-F
A21R38	0757-0317	7	1	RESISTOR 1 33K 1% 125W F TC=0±100	24546	C4-1/8-T0-1331-F
A21R39	0698-3152	8		RESISTOR 3 48K 1% 125W F TC=0±100	24546	C4-1/8-T0-3481-F
A21R40	0757-0458	8	1	RESISTOR 51 1K 1% 125W F TC=0±100	24546	C4-1/8-T0-5112-F
A21R41	0698-3442	7	1	RESISTOR 237 1% 125W F TC=0±100	24546	C4-1/8-T0-237R-F
A21R42	0757-0438	3		RESISTOR 5 11K 1% 125W F TC=0±100	24546	C4-1/8-T0-5111-F
A21R43	0757-0465	6		RESISTOR 100K 1% 125W F TC=0±100	24546	C4-1/8-T0-1003-F
A21R44	2100-3354	9	1	RESISTOR-TRMR 50K 10% C SIDE-ADJ 1-TRN	28480	2100-3354
A21R45	2100-3353	8	1	RESISTOR-TRMR 20K 10% C SIDE-ADJ 1-TRN	28480	2100-3353
A21R46	0757-0438	3		RESISTOR 5 11K 1% 125W F TC=0±100	24546	C4-1/8-T0-5111-F
A21R47	2100-3273	1	1	RESISTOR-TRMR 2K 10% C SIDE-ADJ 1-TRN	28480	2100-3273
A21R48	0698-3441	8	1	RESISTOR 215 1% 125W F TC=0±100	24546	C4-1/8-T0-215R-F
A21R49	0757-0419	0	1	RESISTOR 681 1% 125W F TC=0±100	24546	C4-1/8-T0-681R-F
A21R50	0698-0083	8		RESISTOR 196K 1% 125W F TC=0±100	24546	C4-1/8-T0-1961-F
A21R51	0575-0416	7		RESISTOR 511 1% 125W F TC=0±100	24546	C4-1/8-T0-511R-F
A21R52	0757-0394	0		RESISTOR 51 1K 1% 125W F TC=0±100	24546	C4-1/8-T0-51R1-F
A21R53	0757-0402	1	2	RESISTOR 110 1% 125W F TC=0±100	24546	C4-1/8-T0-110R-F
A21R54	0757-0402	1		RESISTOR 110 1% 125W F TC=0±100	24546	C4-1/8-T0-110R-F
A21R55	0757-0418	9	1	RESISTOR 619 1% 125W F TC=0±100	24546	C4-1/8-T0-619R-F
A21R56	0698-3444	4		RESISTOR 316 1% 125W F TC=0±100	24546	C4-1/8-T0-316R-F
A21R57	0757-0422	5	2	RESISTOR 909 1% 125W F TC=0±100	24546	C4-1/8-T0-909R-F
A21R58	0757-0422	5		RESISTOR 909 1% 125W F TC=0±100	24546	C4-1/8-T0-909R-F
A21TP1	0360-0535	0	6	TERMINAL TEST POINT PCB	00000	ORDER BY DESCRIPTION
A21TP2	0360-0535	0		TERMINAL TEST POINT PCB	00000	ORDER BY DESCRIPTION
A21TP3	0360-0535	0		TERMINAL TEST POINT PCB	00000	ORDER BY DESCRIPTION
A21TP4	0360-0535	0		TERMINAL TEST POINT PCB	00000	ORDER BY DESCRIPTION
A21TP5	0360-0535	0		TERMINAL TEST POINT PCB	00000	ORDER BY DESCRIPTION
A21TP6	0360-0535	0		TERMINAL TEST POINT PCB	00000	ORDER BY DESCRIPTION
A21U1	1826-1229	0	1	IC V RGLTR-FXD-POS 4 8/5 2V TO-202 PKG	27014	LM78M05CP
A21U2	1826-1049	2	1	IC OP AMP PRCN 8-DIP-C PKG	28480	1826-1049
A21U3	1820-2775	1	2	IC GATE TTL ALS NAND TPL 3-INP	01295	SN71546N
A21U4	1826-0161	7	1	IC OP AMP GP QUD 14-DIP-P PKG	04713	MLM324P
A21U5	1820-1423	4	2	IC MV TTL LS MONOSTBL RETRIG DUAL	01295	SN74LS123N
A21U6	1820-2775	1		IC GATE TTL ALS NAND TPL 3-INP	01295	SN71546N
A21U7	1820-1423	4		IC MV TTL LS MONOSTBL RETRIG DUAL	01295	SN74LS123N
A21U8	1820-2656	7	1	IC GATE TTL ALS NAND QUAD 2-INP	01295	SN71338N
A21U9	1820-1858	9	1	IC FF TTL LS D-TYPE OCTL	01295	SN58490N
A21U10	1820-2774	0	1	IC GATE TTL ALS NAND TPL 3-INP	01295	SN74ALS20

A24 Attenuator Driver/Step Recovery Diode (SRD) Bias Circuit Description

ASSEMBLY PURPOSE

The A24 assembly has three functions that relate to the SYTM assembly.

- Step Recovery Diode (SRD) Bias

The SYTM conversion efficiency in the higher multiplication bands is related to the DC bias voltage on the step recovery diode. To maintain optimum SRD bias, the bias voltage is generated as a function of both frequency and power level. The bias variation due to frequency is derived from a voltage proportional to the YO frequency on the A28 SYTM driver assembly. Power level corrections are referenced to a modulator voltage on the A26 linear modulator assembly.

- Pin Switch Control

In low band, the RF input passes unattenuated through the SYTM. In the high bands, the low band RF input is grounded to prevent any low band feedthrough. The low band RF input is grounded through a PIN diode switch in the SYTM; the diode bias control is on the A24 assembly.

- SYTM Temperature Control

Because the SYTM passband varies directly with temperature variations, the SYTM requires temperature control. SYTM temperature is held constant by a thermistor located inside the SYTM, and heater drive circuitry located on the A24 assembly.

FREQUENCY RAMP GENERATOR (BLOCK A)

The frequency ramp generator provides two frequency-tracking ramp voltages for the frequency-dependent element of the SRD bias circuits.

The A28 SYTM driver assembly generates a 1.4 V/GHz signal as an input to the frequency ramp generator. This ramp is inverted and amplified with an offset to produce a descending ramp. The ramp is inverted and offset again to produce an ascending ramp.

MODULATOR VOLTAGE CLAMP (BLOCK B)

The two ramps generated in the frequency ramp generator are attenuated through variable resistors, and summed to form a new ramp, a voltage dependent on frequency and RF power level.

Optimum SRD bias depends heavily on the RF power level to the SYTM (switched YIG-tuned multiplier). SRD BIAS CONT from the A26 linear modulator assembly supplies a power level voltage for the SRD bias adjustments. If the ALC (automatic leveling control) loop goes unleveled, the SRD BIAS CONT line moves abruptly positive, and no longer represents the RF power level. The ramp offsets are adjusted so that when SRD BIAS CONT jumps positive, the base-emitter junctions of the output transistors in block D are reverse-biased, breaking the connection between SRD BIAS CONT and the SRD bias output signal.

BAND DECODER (BLOCK C)

The band decoder provides control signals based on the frequency band in use. HLB0, HLB1, and HLB2, encoded with the current frequency band, are decoded by the 3-to-8 decoder into five distinct control lines.

- Three control lines to comparators for SRD bias on/off FET control.
- Two control lines for the SRD bias amplifier for proper bias level selection.

The Proper Bias for the Current Frequency Band

The comparator outputs for the SRD bias amplifier select:

- Reverse-bias in band 0.
- Forward-bias in band 1.
- The frequency and power-dependent bias in bands 2 and above.

SRD BIAS ADJUSTMENTS (BLOCK D)

In band 1 and above, adjustments provide the frequency and power-dependent bias controls for the SRD bias amplifier.

Three identical circuits, each with three adjustments, produce a synthesized control signal. Only one circuit is selected at a time, through the output on/off FETs, by the band decoding circuitry, depending on the band in use. In each section, two adjustments sum the frequency ramp generator outputs, which are proportional to frequency. The third adjustment subtracts current proportional to the RF power level from the modulator voltage clamp.

EXPONENTIAL GENERATOR (BLOCK E)

The exponential generator shapes the current generated by the SRD bias adjustments circuitry to produce an exponentially shaped voltage output.

SRD BIAS AMPLIFIER (BLOCK F)

The SRD bias amplifier converts the exponential output to a voltage that is fed to the SRD in the SYTM. The MIN adjustment determines the minimum bias voltage (approximately $-0.5V$) for very low power levels. The band decoding inputs control frequency band bias levels.

In band 0, the L0 line is pulled low, forcing the voltage at the output to approximately $+7V$, attenuating the high band output.

In band 1, the L1 line is pulled low, forward biasing the SRD, allowing the fundamental frequency to pass through the SYTM, and minimizing harmonics.

In bands 2 and above, the frequency and power level dependent inputs from exponential bias shaping are used to bias the SRD.

PIN DIODE BIAS (BLOCK G)

When low band is selected, the SYTM PIN diode is reverse-biased, allowing the low band signal to pass through the coupling loop to the SYTM output. When you select high bands, the SYTM PIN diode is turned on, grounding one side of the coupling loop attenuating the low band RF signal and preventing low band feedthrough.

READ STATUS OUTPUT BUFFER (BLOCK H)

Two status lines in the RF section can communicate information to the instrument microprocessor. The output buffer is a six-bit tri-state device.

ATTENUATOR CONTROL LATCH (BLOCK I)

Control latch data-bits 10 through 13 are latched from the instrument data bus on the rising edge of the WLEVEL strobe (10,R1:). Each latched data bit controls one of four attenuator sections. The non-inverting output of U15 activates the driver that removes the attenuator card and inserts the through card for that section. The inverting output of U15 activates the driver that removes the through card and inserts the attenuator card for that section.

ATTENUATOR COIL DRIVERS (BLOCK J)

Attenuator Cards and Through Cards

The A63 attenuator contains four attenuator cards (10, 20, 30, and 30 dB), and four through cards. In each section, latching solenoids switch-in an attenuator card or a through card, depending on the total attenuation required.

Solenoid Coil and Number of Solenoids

Once the actuator reaches full travel, the solenoid coil opens contacts internal to the attenuator. Each coil draws 300 ma for approximately 8 ms, until the internal contacts open the coil circuit. Because each attenuator card requires two solenoids, there are a total of eight separate coils that must be driven at various times, depending on the section switched and whether a through card or an attenuator card is inserted

Coil Drivers and their Protection

The coil drivers, positive-AND drivers, drive the 5V coils of the attenuator. The diode array provides the coil drivers protection from inductive kick-back from the coils.

Filtered Power Source

Because of the large peak current required by the attenuator and drivers, a separately filtered power source is used to prevent current transients from disturbing other functions on this assembly.

SWITCHED YIG-TUNED MULTIPLIER (SYTM) HEATER CONTROL (BLOCK K)

A heater (resistor) and a thermistor inside the A13 SYTM assembly provide control functions to maintain a constant temperature. The thermistor provides a voltage that changes as the temperature changes. This voltage (SYTMTHRM) goes to the A24 assembly SYTM heater control where it is compared to a reference voltage and amplified

As the temperature inside the A13 SYTM rises, the thermistor resistance decreases, causing the SYTMTHRM voltage to increase. When the SYTMTHRM voltage increases, the output voltage of the non-inverting op-amp increases, decreasing the current provided to the A13 SYTM heater, consequently decreasing the temperature.

When the temperature inside the SYTM decreases, the opposite happens, increasing the temperature. This maintains the SYTM temperature at approximately 85°C.

POWER SUPPLY (BLOCK L)

An LC filter circuit on each power supply line reduces any transients due to the attenuator coils or digital signals.

Table A24-1. A24 Attenuator Driver/SRD Bias P1 Pin I/O

Pin	Mnemonic	Levels	Source	Destination
1 19	+20V SYTMHTR	+20V 0 TO +20V	XA5201-16, 40 K	*L A62J18 PIN 8
2 20	SYTMTHRM HLB0	APPROX. -5V TTL (HIGH TRUE)	A62J18-9 XA27P1-46	K *C
3 21	+5.2V HLB1	+5.2V TTL (HIGH TRUE)	XA52P1-17, 18, 41, 42 XA27P1-16	*L *C
4 22	STAT10 HLB2	TTL (LOW TRUE) TTL (HIGH TRUE)	XA23P1-22 XA27P1-47	H *C
5 23	-10V RSTAT	-10V TTL (LOW TRUE)	XA53P1-12, 13, 31, 32 XA27P1-45	*L *H
6 24	1.4V/GHZ PIN BIAS	1.4V/GHZ -4V TO +12V	XA28P1-7 G	*A A62J18 PIN 10
7 25	ATN COIL + SRD BIAS	+5V -10V THRU 2K TO +5V	L F	A62J20 PIN 6 A62J18 PIN 2
8 26	GND GND PLANE	0V 0V	A62 STAR GND INSTRUMENT GND	*L *L
9 27	ATNTH4 ATNAT4	OPEN COLLECTOR OPEN COLLECTOR	J J	A62J20 PIN 4 A62J20 PIN 20
10 28	ATNTH3 ATNAT3	OPEN COLLECTOR OPEN COLLECTOR	J J	A62J20 PIN 11 A62J20 PIN 5
11 29	ATNTH2 ATNAT2	OPEN COLLECTOR OPEN COLLECTOR	J J	A62J20 PIN 3 A62J20 PIN 9
12 30	ATNTH1 ATNAT1	OPEN COLLECTOR OPEN COLLECTOR	J J	A62J20 PIN 13 A62J20 PIN 2
13 31	SRD BIAS CONT HENDKICK	0 TO -5V (LEVELED) TTL (HIGH TRUE)	XA26P1-18 XA28P1-18	B H
14 32	DB9 DB11	TTL TTL	*H *H	* *I
15 33	DB10 WLEVEL	TTL TTL (LOW TRUE)	*H XA27P1-12	*I I
16 34	DB12 DB13	TTL TTL	*H *H	*I *I
17 35	SYTM GND	0V	A62J18-13, 14, 15	*L
18 36	RGND	0V	STAR GND POINT	*L

A single letter in the source or destination column refers to a function block on this assembly schematic.

An asterisk (*) denotes multiple sources or destinations; refer to the A62 motherboard wiring list for a complete representation of signal sources and destinations

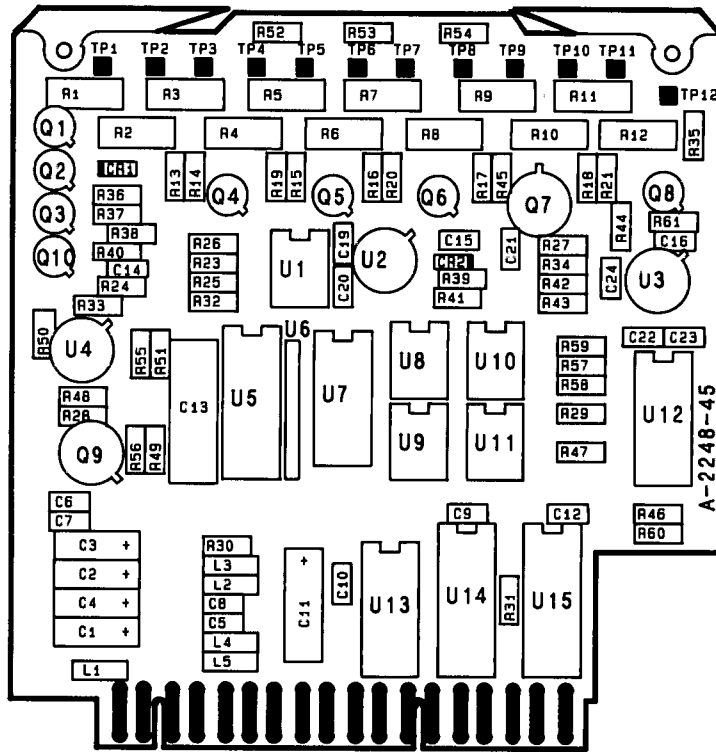

HP Part Number: 08340-60158

Figure A24-1. A24 Attenuator Driver/SRD Bias Component Location Diagram

A24 ATTENUATOR DRIVER AND SRD BIAS
OB340-6018B

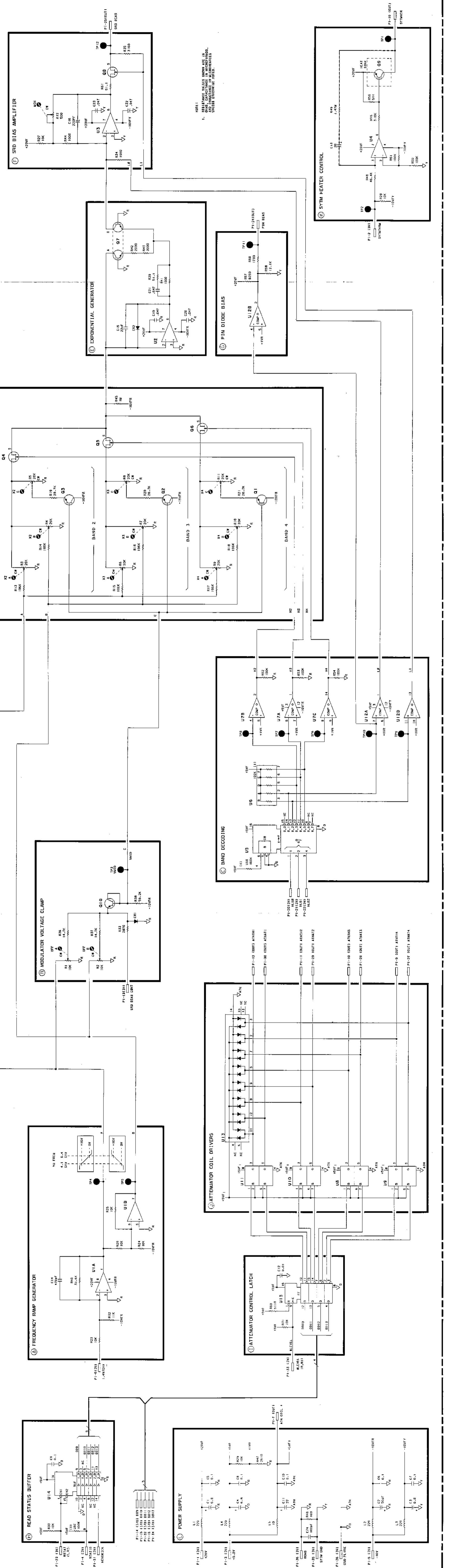

Figure A24-2. A24 Attenuator Driver/SRD Bias Schematic RF Section A24-7/A24-8

A24 Attenuator Driver/Step Recovery Diode (SRD) Bias Component-Level Troubleshooting

Table A24-2. A24 Attenuator Driver/SRD Bias Replaceable Parts

Reference Designation	HP Part Number	C D	Qty	Description	Mfr Code	Mfr Part Number
A24	08340-60158	8	1	ATTENUATOR DRIVER/SRD BIAS ASSEMBLY	28480	08340-60158
A24C1	0180-0116	1	4	CAPACITOR-FXD 6.8UF ± 10% 35VDC TA	56289	150D685X9035B2
A24C2	0180-0116	1		CAPACITOR-FXD 6.8UF ± 10% 35VDC TA	56289	150D685X9035B2
A24C3	0180-0116	1		CAPACITOR-FXD 6.8UF ± 10% 35VDC TA	56289	150D685X9035B2
A24C4	0180-0116	1		CAPACITOR-FXD 6.8UF ± 10% 35VDC TA	56289	150D685X9035B2
A24C5	0160-4835	7	6	CAPACITOR-FXD 1UF ± 10% 50VDC CER	28480	0160-4835
A24C6	0160-4835	7		CAPACITOR-FXD 1UF ± 10% 50VDC CER	28480	0160-4835
A24C7	0160-4835	7		CAPACITOR-FXD 1UF ± 10% 50VDC CER	28480	0160-4835
A24C8	0160-4835	7		CAPACITOR-FXD 1UF ± 10% 50VDC CER	28480	0160-4835
A24C9	0160-4835	7		CAPACITOR-FXD 1UF ± 10% 50VDC CER	28480	0160-4835
A24C10	0160-4835	7		CAPACITOR-FXD 1UF ± 10% 50VDC CER	28480	0160-4835
A24C11	0180-0228	6	1	CAPACITOR-FXD 22UF ± 10% 15VDC TA	56289	150D226X9015B2
A24C12	0160-4832	4	1	CAPACITOR-FXD 01UF ± 10% 100VDC CER	28480	0160-4832
A24C13	0180-0049	9	1	CAPACITOR-FXD 20UF +75-10% 50VDC AL	56289	30D206G050CC2
A24C14	0160-3335	0	1	CAPACITOR-FXD 470PF ± 10% 100VDC CER	28480	0160-3335
A24C15	0160-4787	8	1	CAPACITOR-FXD 22PF ± 5% 100VDC CER 0 ± 30	28480	0160-4787
A24C16	0160-4812	0	1	CAPACITOR-FXD 220PF ± 5% 100VDC CER	28480	0160-4812
A24C17	18			NOT ASSIGNED		
A24C19	0160-0575	4	5	CAPACITOR-FXD 047UF ± 20% 50VDC CER	28480	0160-0575
A24C20	0160-0575	4		CAPACITOR-FXD 047UF ± 20% 50VDC CER	28480	0160-0575
A24C21	0160-0575	4		CAPACITOR-FXD 047UF ± 20% 50VDC CER	28480	0160-0575
A24C22	0160-0575	4		CAPACITOR-FXD 047UF ± 20% 50VDC CER	28480	0160-0575
A24C23	0160-0575	4		CAPACITOR-FXD 047UF ± 20% 50VDC CER	28480	0160-0575
A24C24	0160-4389	6		CAPACITOR-FXD 100PF ± 5PF 100VDC CER	28480	0160-4389
A24CR1	1901-0539	3	1	DIODE-SM SIG SCHOTTKY 20V	28480	1901-0539
A24CR2	1901-0050	3		DIODE-SWITCHING 80V 200MA 2NS DO-35	28480	1901-0050
A24L1	9140-0129	1	4	INDUCTOR RF-CH-MLD 220UH 5% 166DX 385LG	28480	9140-0129
A24L2	9140-0129	1		INDUCTOR RF-CH-MLD 220UH 5% 166DX 385LG	28480	9140-0129
A24L3	9140-0129	1		INDUCTOR RF-CH-MLD 220UH 5% 166DX 385LG	28480	9140-0129
A24L4	9140-0129	1		INDUCTOR RF-CH-MLD 220UH 5% 166DX 385LG	28480	9140-0129
A24L5	9100-0539	3	1	INDUCTOR (MISC ITEM)	28480	9100-0539
A24MP1				NOT ASSIGNED		
A24MP2	4040-0750	7	1	EXTR-PC BD RED POLY C 062-BD-THKNS	28480	4040-0750
A24MP3	4040-0752	9	1	EXTR-PC BD YEL POLY C 062-BD-THKNS	28480	4040-0752
A24MP4	1480-0073	6	2	PIN-ROLL 062-IN-DIA 25-IN-LG BE-CU	28480	1480-0073
A24MP5, 6				NOT ASSIGNED		
A24MP7	1205-0033	6	1	HEAT SINK TO-5/TO-39-CS	28480	1205-0033
A24Q1	1853-0281	9	4	TRANSISTOR PNP 2N2907A SI TO-18 PD=400MW	04713	2N2907A
A24Q2	1853-0281	9		TRANSISTOR PNP 2N2907A SI TO-18 PD=400MW	04713	2N2907A
A24Q3	1853-0281	9		TRANSISTOR PNP 2N2907A SI TO-18 PD=400MW	04713	2N2907A
A24Q4	1855-0386	9	3	TRANSISTOR J-FET 2N4392 N-CHAN D-MODE	04713	2N4392
A24Q5	1855-0386	9		TRANSISTOR J-FET 2N4392 N-CHAN D-MODE	04713	2N4392
A24Q6	1855-0386	9		TRANSISTOR J-FET 2N4392 N-CHAN D-MODE	04713	2N4392
A24Q7	1854-0475	5	1	TRANSISTOR DUAL NPN PD=750MW	28480	1854-0475
A24Q8	1855-0420	2	1	TRANSISTOR J-FET 2N4391 N-CHAN D-MODE	01295	2N4391
A24Q9	1853-0213	4	1	TRANSISTOR PNP SI TO-39 PD=1W FT=100MHZ	28480	1853-0213
A24Q10	1853-0281	9		TRANSISTOR PNP 2N2907A SI TO-18 PD=400MW	28480	1853-0281
A24R1	2100-3274	2	2	RESISTOR-TRMR 10K 10% C SIDE-ADJ 1-TRN	28480	2100-3274
A24R2	2100-3274	2		RESISTOR-TRMR 10K 10% C SIDE-ADJ 1-TRN	28480	2100-3274
A24R3	2100-3353	8	9	RESISTOR-TRMR 20K 10% C SIDE-ADJ 1-TRN	28480	2100-3353
A24R4	2100-3353	8		RESISTOR-TRMR 20K 10% C SIDE-ADJ 1-TRN	28480	2100-3353
A24R5	2100-3353	8		RESISTOR-TRMR 20K 10% C SIDE-ADJ 1-TRN	28480	2100-3353
A24R6	2100-3353	8		RESISTOR-TRMR 20K 10% C SIDE-ADJ 1-TRN	28480	2100-3353
A24R7	2100-3353	8		RESISTOR-TRMR 20K 10% C SIDE-ADJ 1-TRN	28480	2100-3353
A24R8	2100-3353	8		RESISTOR-TRMR 20K 10% C SIDE-ADJ 1-TRN	28480	2100-3353
A24R9	2100-3353	8		RESISTOR-TRMR 20K 10% C SIDE-ADJ 1-TRN	28480	2100-3353
A24R10	2100-3353	8		RESISTOR-TRMR 20K 10% C SIDE-ADJ 1-TRN	28480	2100-3353
A24R11	2100-3353	8		RESISTOR-TRMR 20K 10% C SIDE-ADJ 1-TRN	28480	2100-3353
A24R12	2100-3351	6	1	RESISTOR-TRMR 500 10% C SIDE-ADJ 1-TRN	28480	2100-3351
A24R13	0698-3453	2	6	RESISTOR 196K 1% 125W F TC=0 ± 100	24546	C4-1/8-T0-1963-F
A24R14	0698-3453	2		RESISTOR 196K 1% 125W F TC=0 ± 100	24546	C4-1/8-T0-1963-F
A24R15	0698-3453	2		RESISTOR 196K 1% 125W F TC=0 ± 100	24546	C4-1/8-T0-1963-F
A24R16	0698-3453	2		RESISTOR 196K 1% 125W F TC=0 ± 100	24546	C4-1/8-T0-1963-F
A24R17	0698-3453	2		RESISTOR 196K 1% 125W F TC=0 ± 100	24546	C4-1/8-T0-1963-F
A24R18	0698-3453	2		RESISTOR 196K 1% 125W F TC=0 ± 100	24546	C4-1/8-T0-1963-F
A24R19	0698-3449	6	3	RESISTOR 28.7K 1% 125W F TC=0 ± 100	24546	C4-1/8-T0-2872-F
A24R20	0698-3449	6		RESISTOR 28.7K 1% 125W F TC=0 ± 100	24546	C4-1/8-T0-2872-F

A24 Attenuator Driver/Step Recovery Diode (SRD) Bias Component-Level Troubleshooting

Table A24-2. A24 Attenuator Driver/SRD Bias Replaceable Parts

Reference Designation	HP Part Number	C D	Qty	Description	Mfr Code	Mfr Part Number
A24R21	0698-3449	6		RESISTOR 28 7k 1% 125W F TC=0±100	24546	C4-1/8-T0-2872-F
A24R22				NOT ASSIGNED		
A24R23	0757-0442	9	9	RESISTOR 10k 1% 125W F TC=0±100	24546	C4-1/8-T0-1002-F
A24R24	0757-0442	9		RESISTOR 10k 1% 125W F TC=0±100	24546	C4-1/8-T0-1002-F
A24R25	0757-0442	9		RESISTOR 10k 1% 125W F TC=0±100	24546	C4-1/8-T0-1002-F
A24R26	0757-0442	9		RESISTOR 10k 1% 125W F TC=0±100	24546	C4-1/8-T0-1002-F
A24R27	0757-0442	9		RESISTOR 10k 1% 125W F TC=0±100	24546	C4-1/8-T0-1002-F
A24R28	0757-0442	9		RESISTOR 10k 1% 125W F TC=0±100	24546	C4-1/8-T0-1002-F
A24R29	0757-0442	9		RESISTOR 10k 1% 125W F TC=0±100	24546	C4-1/8-T0-1002-F
A24R30	0757-0442	9		RESISTOR 10k 1% 125W F TC=0±100	24546	C4-1/8-T0-1002-F
A24R31	0757-0442	9		RESISTOR 10k 1% 125W F TC=0±100	24546	C4-1/8-T0-1002-F
A24R32	0757-0443	0	1	RESISTOR 11k 1% 125W F TC=0±100	24546	C4-1/8-T0-1102-F
A24R33	0698-3151	7	1	RESISTOR 2 87k 1% 125W F TC=0±100	24546	C4-1/8-T0-2871-F
A24R34	0698-0083	8	2	RESISTOR 1 96k 1% 125W F TC=0±100	24546	C4-1/8-T0-1961-F
A24R35	0698-0083	8		RESISTOR 1 96k 1% 125W F TC=0±100	24546	C4-1/8-T0-1961-F
A24R36	0698-3156	2	2	RESISTOR 14 7k 1% 125W F TC=0±100	24546	C4-1/8-T0-1472-F
A24R37	0698-3156	2		RESISTOR 14 7k 1% 125W F TC=0±100	24546	C4-1/8-T0-1472-F
A24R38	0698-7278	7	1	RESISTOR 56 2k 1% 05W F TC=0±100	28480	0698-7278
A24R39	0757-0394	0	1	RESISTOR 51 1 1% 125W F TC=0±100	24546	C4-1/8-T0-51R1-F
A24R40	0698-3160	8	1	RESISTOR 31 6k 1% 125W F TC=0±100	24546	C4-1/8-T0-3162-F
A24R41	0757-0280	3	2	RESISTOR 1k 1% 125W F TC=0±100	24546	C4-1/8-T0-1001-F
A24R42	0698-6624	5	1	RESISTOR 2k 1% 125W F TC=0±25	28480	0698-6624
A24R43	0811-3575	1	1	RESISTOR-3k OHM 2% 12W	28480	0811-3575
A24R44	0757-0280	3		RESISTOR 1k 1% 125W F TC=0±100	24546	C4-1/8-T0-1001-F
A24R45	0698-8827	4	1	RESISTOR 1M 1% 125W F TC=0±100	28480	0698-8827
A24R46	0757-0401	0	1	RESISTOR 100 1% 125W F TC=0±100	24546	C4-1/8-T0-101-F
A24R47	0698-0085	0	1	RESISTOR 2 61k 1% 125W F TC=0±100	24546	C4-1/8-T0-2611-F
A24R48	0698-3162	0	1	RESISTOR 46 4k 1% 125W F TC=0±100	24546	C4-1/8-T0-4642-F
A24R49	0699-0068	1	1	RESISTOR-1 47 MEGOHM 1% 12W	28480	0699-0068
A24R50	0757-0465	6	5	RESISTOR 100k 1% 125W F TC=0±100	24546	C4-1/8-T0-1003-F
A24R51	0757-0465	6		RESISTOR 100k 1% 125W F TC=0±100	24546	C4-1/8-T0-1003-F
A24R52	0757-0465	6		RESISTOR 100k 1% 125W F TC=0±100	24546	C4-1/8-T0-1003-F
A24R53	0757-0465	6		RESISTOR 100k 1% 125W F TC=0±100	24546	C4-1/8-T0-1003-F
A24R54	0757-0465	6		RESISTOR 100k 1% 125W F TC=0±100	24546	C4-1/8-T0-1003-F
A24R55	0757-0279	0	1	RESISTOR 3 16k 1% 125W F TC=0±100	24546	C4-1/8-T0-3161-F
A24R56	0757-0416	7	1	RESISTOR 511 1% 125W F TC=0±100	24546	C4-1/8-T0-5110-F
A24R57	0757-0441	8	1	RESISTOR 8 25k 1% 125W F TC=0±100	24546	C4-1/8-T0-8251-F
A24R58	0757-0444	1	1	RESISTOR 12 1k 1% 125W F TC=0±100	24546	C4-1/8-T0-1212-F
A24R59	0757-0278	9	1	RESISTOR 1 78k 1% 125W F TC=0±100	24546	C4-1/8-T0-1781-F
A24R60	0757-0438	3	1	RESISTOR 5 11k 1% 125W F TC=0±100	24546	C4-1/8-T0-5111-F
A24R61	0698-7205	0	1	RESISTOR 51 1 1% 125W F TC=0±100	24546	C4-1/8-T0-51R1-F
A24TP1	0360-0535	0	12	TERMINAL TEST POINT PCB	00000	ORDER BY DESCRIPTION
A24TP2	0360-0535	0		TERMINAL TEST POINT PCB	00000	ORDER BY DESCRIPTION
A24TP3	0360-0535	0		TERMINAL TEST POINT PCB	00000	ORDER BY DESCRIPTION
A24TP4	0360-0535	0		TERMINAL TEST POINT PCB	00000	ORDER BY DESCRIPTION
A24TP5	0360-0535	0		TERMINAL TEST POINT PCB	00000	ORDER BY DESCRIPTION
A24TP6	0360-0535	0		TERMINAL TEST POINT PCB	00000	ORDER BY DESCRIPTION
A24TP7	0360-0535	0		TERMINAL TEST POINT PCB	00000	ORDER BY DESCRIPTION
A24TP8	0360-0535	0		TERMINAL TEST POINT PCB	00000	ORDER BY DESCRIPTION
A24TP9	0360-0535	0		TERMINAL TEST POINT PCB	00000	ORDER BY DESCRIPTION
A24TP10	0360-0535	0		TERMINAL TEST POINT PCB	00000	ORDER BY DESCRIPTION
A24TP11	0360-0535	0		TERMINAL TEST POINT PCB	00000	ORDER BY DESCRIPTION
A24TP12	0360-0535	0		TERMINAL TEST POINT PCB	00000	ORDER BY DESCRIPTION
A24U1	1826-0785	1	1	IC OP AMP LOW-BIAS-H-IMPED DUAL 8-DIP-C	01295	TL072ACJG
A24U2	1826-0828	3	2	IC-15G M1 OP AMP	06665	OP-15GJ
A24U3	1826-0828	3		IC-15G M1 OP AMP	06665	OP-15GJ
A24U4	1826-1349	5	1	IC OP AMP TO-99 PKG	28480	1826-1349
A24U5	1820-1216	3	1	IC DCDR TTL LS 3-TO-8-LINE 3-INP	01295	SN74LS138N
A24U6	1810-0395	6	1	NETWORK-RES 8-SIP47 0k OHM X 7	11236	750-81-R47K
A24U7	1826-0138	8	2	IC COMPARATOR GP QUAD 14-DIP-P PKG	01295	LM339N
A24U8	1820-0535	7	4	IC DRVR TTL AND DUAL 2-INP	01295	SN75451BP
A24U9	1820-0535	7		IC DRVR TTL AND DUAL 2-INP	01295	SN75451BP
A24U10	1820-0535	7		IC DRVR TTL AND DUAL 2-INP	01295	SN75451BP
A24U11	1820-0535	7		IC DRVR TTL AND DUAL 2-INP	01295	SN75451BP
A24U12	1826-0138	8		IC COMPARATOR GP QUAD 14-DIP-P PKG	01295	LM339N
A24U13	1906-0074	1	1	DIODE-ARRAY 50V 400MA	28480	1906-0074
A24U14	1820-1491	6	1	IC BFR TTL LS NON-INV HEX 1-INP	01295	SN74LS367AN
A24U15	1820-1195	7	1	IC FF TTL LS D-TYPE POS-EDGE-TRIG COM	01295	SN74LS175N

A25 ALC Detector Circuit Description

ASSEMBLY PURPOSE

The A25 ALC detector assembly processes the voltage from either internal or external detectors, producing an output voltage proportional to the RF power level. The output voltage is compared to a reference level voltage on the A26 linear modulator assembly, and the resulting error drives the RF modulators, controlling the RF leveling loop.

INTERNAL DETECTOR LOG CONVERTER (BLOCK A)

The internal dual-slope log converter receives the detected RF voltage and outputs a signal proportional to the RF power level in dBm

Band Detector Selection

Internal low or high band crystal detector inputs are selected by the input control FETs. Comparator outputs are controlled by the LHET input, determining which detector input is selected. The low and high band offset adjustments provide the small voltage offsets required to adjust for low RF power levels due to detector non-linearities.

DC and AC Amplifiers

An operational amplifier and a transistor form a low-drift, high-gain DC amplifier that provides the DC current drive for the log amplifier. Discrete FET and bipolar transistors form a high-speed differential ac amplifier that improves the log amplifier high frequency response. The output summing amplifier sums the log amplifier current drive DC and ac components.

Log Amplifier

Two matched pair bipolar devices form the dual slope log amplifier. The dual slope amplifier tracks the detector characteristics in the square-law region and doubles the gain when the detectors operate in the linear region, providing an output voltage proportional to the RF power level over a wide range of power levels.

The logger bias circuitry provides the current source for the log amplifier. Transistors provide the adjustable bias currents, and control comparators turn on the bias for low or high band operation. Low and high band adjustments are provided for low band or high bands. A thermistor mounted internal to the A12 low band splitter/detector provides thermal compensation for the bias circuitry.

Output Clamp

Clamp transistors clamp the log amplifier negative excursions when pulse modulation turns the RF power off. The clamp voltage is approximately $-0.12V$, but varies with different power levels.

X5 AMPLIFIER (BLOCK B)

A discrete differential amplifier, with a gain of five, buffers the log converter's high impedance output. In addition, the LVLCOR (level correction) signal from the A27 level control assembly is summed with the detected voltage.

SAMPLE/HOLD (BLOCK C)

The sample/hold circuit stores the detected RF level when the RF power is off during pulse modulation. A FET switch, controlled by the A21 pulse modulator assembly through transistor drivers, provides the control for the sampling capacitor. During the hold stage, the small loss of charge from the sampling capacitor is compensated for by a small compensation capacitor. An adjustment provides control of the compensation level.

LEVEL METER AMPLIFIER (BLOCK D)

The level meter amplifier buffers and filters the sample/hold voltage. The voltage gain is approximately seven, with a low-pass filter cutoff frequency of 5 Hz. For thermal stability, temperature sensitive resistors track the logger gain drift. The output buffer provides an output proportional to the RF power level, and is used by the instrument microprocessor to display the output power level.

SYSTEM LEVELING RELAY DRIVER (BLOCK E)

System leveling provides calibrated external leveling compatible with the HP 83550 series millimeter-wave source modules, which have internal detectors, log amplifiers, and thermal compensation

When in the system leveling mode, the HSYS control signal, through FET drivers, selects the external detector input for the ALC sample and hold circuitry through the system leveling relay. The external detector input allows the sample/hold circuitry to monitor an external input. The POWER dBm display shows the external input power level, **not** the instrument power output

NOTE: For impedance matching in the system leveling mode, the external detector input is terminated in a 50 Ω resistor.

Power meter leveling and external crystal leveling modes are controlled by the HMTR and HINT control lines in the function switches and external detector circuitry (block F). When either power meter or external crystal leveling is selected, the EX DET input is routed through the external detector log converter (block H).

NOTE: Because the HP 83550 series source modules have internal log amplifiers, system leveling mode diverts the EXT DET input to the sample/hold circuitry.

FUNCTION SWITCHES AND EXTERNAL DETECTOR FREQUENCY COMPENSATION (BLOCK F)

The external detector log converter output is buffered, with a DC voltage gain of approximately 10. Open collector drivers and FET switches select the internal or external detectors to be used on the A26 linear modulator assembly. See Table A25-1 for a function select truth table for the FET switches.

Table A25-1. Function Select Truth Table

Leveling Mode		Q27	Q28	Q29
Internal		ON	OFF	OFF
External	Crystal Detector	OFF	ON	OFF
	Power Meter	OFF	ON	ON
Unleveled (Shift Meter) (Shift Internal) (Shift RF)		OFF	OFF	OFF

Table A25-2. HMTR and HINT Functions

HMTR	HINT	
	Low = 0	High = 1
High = 1	External Power Leveling	"Open-Loop"
Low = 0	External Crystal Leveling	Internal Leveling

LEVEL REFERENCE TEMPERATURE COMPENSATION (BLOCK G)

The reference voltage changes with temperature to compensate for gain drift in the log converters. The temperature compensated reference voltage output (TCREF) is summed (on the A26 linear modulator assembly) with the AM and marker inputs, and compared to the output of the A25 ALC detector assembly. In the system leveling mode, the temperature sensitive network is disconnected, and resistors are connected that have a temperature coefficient of zero.

EXTERNAL LOG CONVERTER (BLOCK H)

Monitoring the RF power level externally through the external leveling input, the external detector log converter provides the logging function similar to the log converter in block A. An absolute value converter lets you use either a positive or a negative detector, with adjustments for voltage offsets to make the currents seen by the log amplifier the same.

The log amplifier is configured as a single-slope converter, with its negative output clamped at 0.3V. An adjustment provides log amplifier balancing at low output levels.

NOTE: When you use an external detector, the sample/hold is not effective during pulse modulation. Also, the front panel power dBm display continues to display the internally detected power level (instrument output power), rather than the externally detected power level.

POWER SUPPLY (BLOCK I)

LC filtering removes noise from the +20V and -10V supply lines. Additional RC filtering keeps the +20V and -10V extra clean for use in the internal logger. The +1.5V supply is the reference voltage for the comparators.

A25 ALC Detector Circuit Description

Table A25-3. A25 ALC Detector Pin I/O

Pin	Mnemonic	Levels	Source	Destination
1 23				
2 24	DET S/H + DET S/H -	+4.5/+3.5V +3.5/+4.5V	XA21P1-3 XA21P1-21	C C
3 25	HPLSEN	TTL (HIGH TRUE)	XA26P1-2	*NOT USED
4 26	THERM 1 THERM 2	-1V TO -8V -10V	A62J34-3 A62J34-1	A A
5 27	+20V +20V	+20V +20V	XA52P1-16, 40 XA52P1-16, 40	*H *H
6 28	+5.2V +5.2V	+5.2V +5.2V	XA52P1-17, 18, 41, 42 XA52P1-17, 18, 41, 42	*NOT USED *NOT USED
7 29	-10V -10V	-10V -10V	XA53P1-12, 13, 31, 32 XA53P1-12, 13, 31, 32	*H *H
8 30				
9 31	GND GND	0V 0V	A62 STAR GND A62 STAR GND	* *
10 32	GND DETOUT	0V -30mV/dB, 0V = 0dBm	A62 STAR GND F	* XA26P1-10
11 33	DETLVL	-200mV/dB, 0V = 0dBm	D	XA27P1-29
12 34	RGND RGND	0V 0V	STAR GND POINT STAR GND POINT	*H *H
13 35	LVLREF TCREF	0.2V/dB, 0V = 0dBm -200mV/dB, 0V = 0dBm	XA27P1-30 G	G XA26P1-12
14 36	LVLCOR HMTR	+1.25dB/VOLT, 0V = 0dB TTL (HIGH TRUE)	B XA26P1-13	XA27P1-62 A F
15 37	LHET	TTL (LOW TRUE)	XA27P1-20	*A
16 38				
17 39	LDETBW	TTL (LOW TRUE)	XA26P1-9	*NOT USED
18 40				
19 41				
20 42	HINT	TTL (HIGH TRUE)	XA26P1-42	F
21 43	EXDETR	0V	*	E
22 44	EXDET	0.5mV - 2V	A26J16 SMC CENTER	E

A single letter in the source or destination column refers to a function block on this assembly schematic.

An asterisk (*) denotes multiple sources or destinations; refer to the A62 motherboard wiring list for a complete representation of signal sources and destinations.

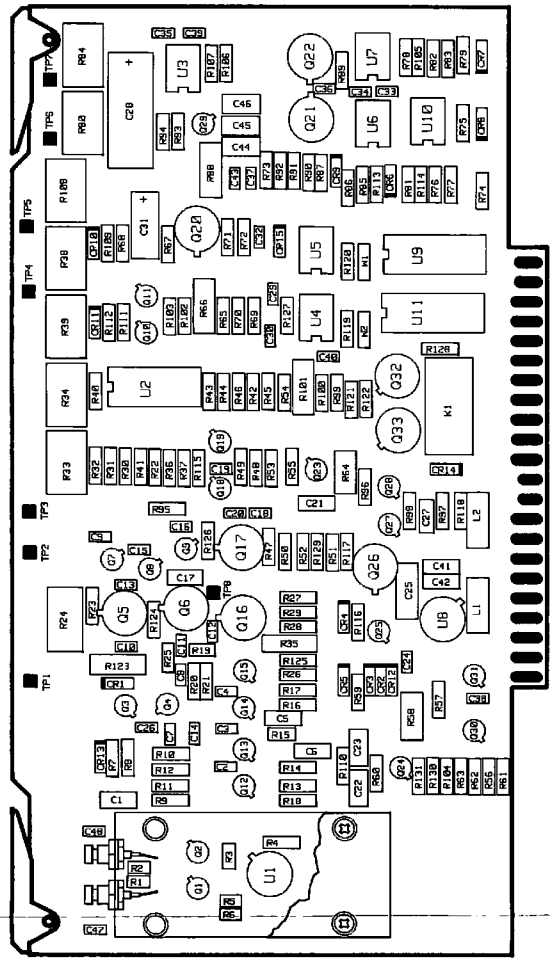

HP Part Number: 08340-60263

Figure A25-1. A25 ALC Detector Component Location Diagram

A25 ALC DETECTOR
08340-60263

RESISTANCE VALUES SHOWN ARE IN OHMS UNLESS OTHERWISE NOTED.
RESISTANCE VALUES SHOWN ARE IN OHMS UNLESS OTHERWISE NOTED.
RESISTANCE VALUES SHOWN ARE IN OHMS UNLESS OTHERWISE NOTED.

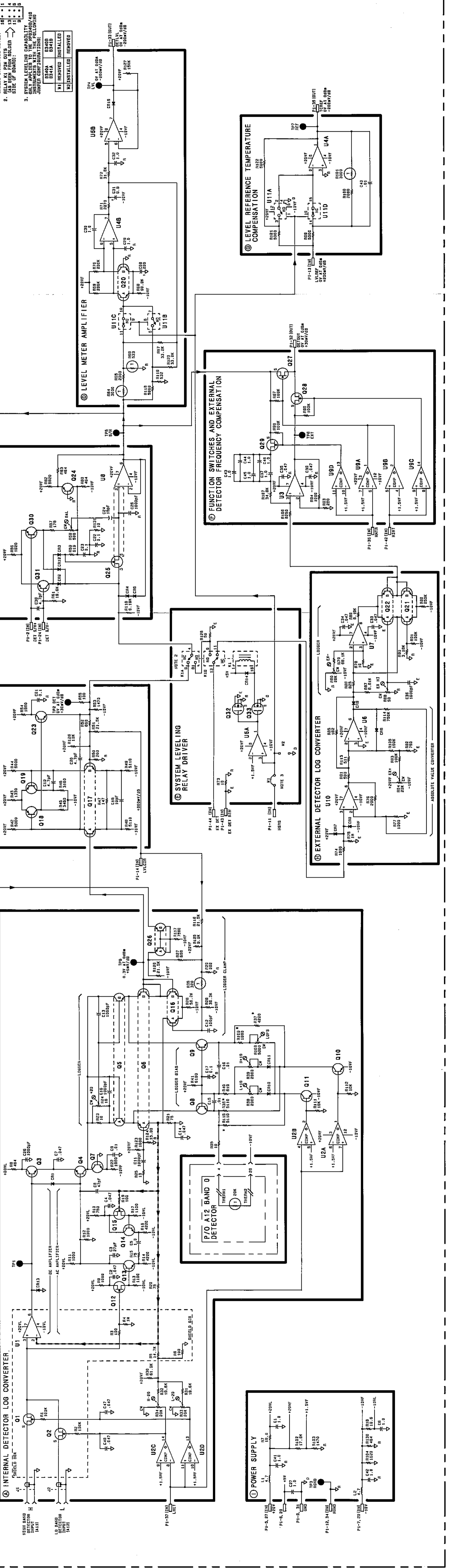

- NOTES:
- RESISTANCE VALUES SHOWN ARE IN OHMS UNLESS OTHERWISE NOTED.
 - RELAY K1 PIN OUTS (AS SHOWN FROM SOLDIER SIDE OF BOARD):

RELAY PIN	FUNCTION	STATUS
1	COMMON	REMOVED
2	NO. 1	REMOVED
3	NO. 2	REMOVED
4	NO. 3	REMOVED
5	NO. 4	REMOVED
6	NO. 5	REMOVED
7	NO. 6	REMOVED
8	NO. 7	REMOVED
9	NO. 8	REMOVED
10	NO. 9	REMOVED
11	NO. 10	REMOVED
12	NO. 11	REMOVED
13	NO. 12	REMOVED
14	NO. 13	REMOVED
15	NO. 14	REMOVED
16	NO. 15	REMOVED
17	NO. 16	REMOVED
18	NO. 17	REMOVED
19	NO. 18	REMOVED
20	NO. 19	REMOVED
21	NO. 20	REMOVED
22	NO. 21	REMOVED
23	NO. 22	REMOVED
24	NO. 23	REMOVED
25	NO. 24	REMOVED
26	NO. 25	REMOVED
27	NO. 26	REMOVED
28	NO. 27	REMOVED
29	NO. 28	REMOVED
30	NO. 29	REMOVED
31	NO. 30	REMOVED
32	NO. 31	REMOVED
33	NO. 32	REMOVED
34	NO. 33	REMOVED
35	NO. 34	REMOVED
36	NO. 35	REMOVED
37	NO. 36	REMOVED
38	NO. 37	REMOVED
39	NO. 38	REMOVED
40	NO. 39	REMOVED
41	NO. 40	REMOVED
42	NO. 41	REMOVED
43	NO. 42	REMOVED
44	NO. 43	REMOVED
45	NO. 44	REMOVED
46	NO. 45	REMOVED
47	NO. 46	REMOVED
48	NO. 47	REMOVED
49	NO. 48	REMOVED
50	NO. 49	REMOVED
51	NO. 50	REMOVED
52	NO. 51	REMOVED
53	NO. 52	REMOVED
54	NO. 53	REMOVED
55	NO. 54	REMOVED
56	NO. 55	REMOVED
57	NO. 56	REMOVED
58	NO. 57	REMOVED
59	NO. 58	REMOVED
60	NO. 59	REMOVED
61	NO. 60	REMOVED
62	NO. 61	REMOVED
63	NO. 62	REMOVED
64	NO. 63	REMOVED
65	NO. 64	REMOVED
66	NO. 65	REMOVED
67	NO. 66	REMOVED
68	NO. 67	REMOVED
69	NO. 68	REMOVED
70	NO. 69	REMOVED
71	NO. 70	REMOVED
72	NO. 71	REMOVED
73	NO. 72	REMOVED
74	NO. 73	REMOVED
75	NO. 74	REMOVED
76	NO. 75	REMOVED
77	NO. 76	REMOVED
78	NO. 77	REMOVED
79	NO. 78	REMOVED
80	NO. 79	REMOVED
81	NO. 80	REMOVED
82	NO. 81	REMOVED
83	NO. 82	REMOVED
84	NO. 83	REMOVED
85	NO. 84	REMOVED
86	NO. 85	REMOVED
87	NO. 86	REMOVED
88	NO. 87	REMOVED
89	NO. 88	REMOVED
90	NO. 89	REMOVED
91	NO. 90	REMOVED
92	NO. 91	REMOVED
93	NO. 92	REMOVED
94	NO. 93	REMOVED
95	NO. 94	REMOVED
96	NO. 95	REMOVED
97	NO. 96	REMOVED
98	NO. 97	REMOVED
99	NO. 98	REMOVED
100	NO. 99	REMOVED

- SYSTEM LEVELING CAPABILITY ONLY APPLIED TO THE UP8340B/A10 INSTRUMENTS WITH THE FOLLOWING JUMPER CONFIGURATIONS:

JUMPER	STATUS
J1	REMOVED
J2	REMOVED
J3	REMOVED
J4	REMOVED
J5	REMOVED
J6	REMOVED
J7	REMOVED
J8	REMOVED
J9	REMOVED
J10	REMOVED
J11	REMOVED
J12	REMOVED
J13	REMOVED
J14	REMOVED
J15	REMOVED
J16	REMOVED
J17	REMOVED
J18	REMOVED
J19	REMOVED
J20	REMOVED
J21	REMOVED
J22	REMOVED
J23	REMOVED
J24	REMOVED
J25	REMOVED
J26	REMOVED
J27	REMOVED
J28	REMOVED
J29	REMOVED
J30	REMOVED
J31	REMOVED
J32	REMOVED
J33	REMOVED
J34	REMOVED
J35	REMOVED
J36	REMOVED
J37	REMOVED
J38	REMOVED
J39	REMOVED
J40	REMOVED
J41	REMOVED
J42	REMOVED
J43	REMOVED
J44	REMOVED
J45	REMOVED
J46	REMOVED
J47	REMOVED
J48	REMOVED
J49	REMOVED
J50	REMOVED
J51	REMOVED
J52	REMOVED
J53	REMOVED
J54	REMOVED
J55	REMOVED
J56	REMOVED
J57	REMOVED
J58	REMOVED
J59	REMOVED
J60	REMOVED
J61	REMOVED
J62	REMOVED
J63	REMOVED
J64	REMOVED
J65	REMOVED
J66	REMOVED
J67	REMOVED
J68	REMOVED
J69	REMOVED
J70	REMOVED
J71	REMOVED
J72	REMOVED
J73	REMOVED
J74	REMOVED
J75	REMOVED
J76	REMOVED
J77	REMOVED
J78	REMOVED
J79	REMOVED
J80	REMOVED
J81	REMOVED
J82	REMOVED
J83	REMOVED
J84	REMOVED
J85	REMOVED
J86	REMOVED
J87	REMOVED
J88	REMOVED
J89	REMOVED
J90	REMOVED
J91	REMOVED
J92	REMOVED
J93	REMOVED
J94	REMOVED
J95	REMOVED
J96	REMOVED
J97	REMOVED
J98	REMOVED
J99	REMOVED
J100	REMOVED

Figure A25-2. A25 ALC Detector Schematic A25-9/A25-10 RF Section

A25 ALC Detector Circuit Description

Table A25-4. A25 ALC Detector Replaceable Parts

Reference Designation	HP Part Number	C D	Qty	Description	Mfr Code	Mfr Part Number
A25	08340-60263	6	1	ALC DETECTOR ASSEMBLY	28480	08340-60263
A25C1	0160-4535	4	14	CAPACITOR-FXD 1UF ±10% 50VDC CER	28480	0160-4535
A25C2	0160-0575	4	10	CAPACITOR-FXD 047UF ±20% 50VDC CER	28480	0160-0575
A25C3	0160-4493	3	1	CAPACITOR-FXD 27PF ±5% 200VDC CER 0±30	28480	0160-4493
A25C4	0160-0575	4		CAPACITOR-FXD 047UF ±20% 50VDC CER	28480	0160-0575
A25C5	0160-4535	4		CAPACITOR-FXD 1UF ±10% 50VDC CER	28480	0160-4535
A25C6	0160-4535	4		CAPACITOR-FXD 1UF ±10% 50VDC CER	28480	0160-4535
A25C7	0160-0575	4		CAPACITOR-FXD 047UF ±20% 50VDC CER	28480	0160-0575
A25C8	0160-4387	4	1	CAPACITOR-FXD 47PF ±5% 200VDC CER 0±30	28480	0160-4387
A25C9	0160-3879	7	4	CAPACITOR-FXD 01UF ±20% 100VDC CER	28480	0160-3879
A25C10	0160-3878	6	5	CAPACITOR-FXD 1000PF ±20% 100VDC CER	28480	0160-3878
A25C11	0160-3878	6		CAPACITOR-FXD 1000PF ±20% 100VDC CER	28480	0160-3878
A25C12	0160-4389	6	1	CAPACITOR-FXD 100PF ±5PF 200VDC CER	28480	0160-4389
A25C13	0160-3878	6		CAPACITOR-FXD 1000PF ±20% 100VDC CER	28480	0160-3878
A25C14	0160-0575	4		CAPACITOR-FXD 047UF ±20% 50VDC CER	28480	0160-0575
A25C15	0160-3879	7		CAPACITOR-FXD 01UF ±20% 100VDC CER	28480	0160-3879
A25C16	0160-3879	7		CAPACITOR-FXD 01UF ±20% 100VDC CER	28480	0160-3879
A25C17	0160-4084	8	4	CAPACITOR-FXD 1UF ±20% 50VDC CER	28480	0160-4084
A25C18	0160-3874	2	1	CAPACITOR-FXD 10PF ±5PF 200VDC CER	28480	0160-3874
A25C19	0160-3873	1	3	CAPACITOR-FXD 4 7PF ±5PF 200VDC CER	28480	0160-3873
A25C20	0160-3873	1		CAPACITOR-FXD 4 7PF ±5PF 200VDC CER	28480	0160-3873
A25C21	0160-4084	8		CAPACITOR-FXD 1UF ±20% 50VDC CER	28480	0160-4084
A25C22	0160-4084	8		CAPACITOR-FXD 1UF ±20% 50VDC CER	28480	0160-4084
A25C23	0160-4084	8		CAPACITOR-FXD 1UF ±20% 50VDC CER	28480	0160-4084
A25C24	0160-4789	0	1	CAPACITOR-FXD 15PF ±5% 100VDC CER 0±30	28480	0160-4789
A25C25	0160-0153	4	1	CAPACITOR-FXD 1000PF ±10% 200VDC POLYE	28480	0160-0153
A25C26	0160-3878	6		CAPACITOR-FXD 1000PF ±20% 100VDC CER	28480	0160-3878
A25C27	0160-4535	4		CAPACITOR-FXD 1UF ±10% 50VDC CER	28480	0160-4535
A25C28	0180-2208	6	1	CAPACITOR-FXD 220UF ±10% 10VDC TA	56289	150D227X9010S2
A25C29	0160-4535	4		CAPACITOR-FXD 1UF ±10% 50VDC CER	28480	0160-4535
A25C30	0160-4535	4		CAPACITOR-FXD 1UF ±10% 50VDC CER	28480	0160-4535
A25C31	0180-0116	1	1	CAPACITOR-FXD 6.8UF ±10% 35VDC TA	56289	150D685X9035B2
A25C32	0160-4535	4		CAPACITOR-FXD 1UF ±10% 50VDC CER	28480	0160-4535
A25C33	0160-0575	4		CAPACITOR-FXD 047UF ±20% 50VDC CER	28480	0160-0575
A25C34	0160-0575	4		CAPACITOR-FXD 047UF ±20% 50VDC CER	28480	0160-0575
A25C35	0160-0575	4		CAPACITOR-FXD 047UF ±20% 50VDC CER	28480	0160-0575
A25C36	0160-3878	6		CAPACITOR-FXD 1000PF ±20% 100VDC CER	28480	0160-3878
A25C37	0160-4535	4		CAPACITOR-FXD 1UF ±10% 50VDC CER	28480	0160-4535
A25C38	0160-3873	1		CAPACITOR-FXD 4 7PF ±5PF 200VDC CER	28480	0160-3873
A25C39	0160-0575	4		CAPACITOR-FXD 047UF ±20% 50VDC CER	28480	0160-0575
A25C40	0160-3879	7		CAPACITOR-FXD 01UF ±20% 100VDC CER	28480	0160-3879
A25C41	0160-4535	4		CAPACITOR-FXD 1UF ±10% 50VDC CER	28480	0160-4535
A25C42	0160-4535	4		CAPACITOR-FXD 1UF ±10% 50VDC CER	28480	0160-4535
A25C43	0160-4535	4		CAPACITOR-FXD 1UF ±10% 50VDC CER	28480	0160-4535
A25C44	0160-4535	4		CAPACITOR-FXD 1UF ±10% 50VDC CER	28480	0160-4535
A25C45	0160-4535	4		CAPACITOR-FXD 1UF ±10% 50VDC CER	28480	0160-4535
A25C46	0160-4535	4		CAPACITOR-FXD 1UF ±10% 50VDC CER	28480	0160-4535
A25C47	0160-0575	4		CAPACITOR-FXD 047UF ±20% 50VDC CER	28480	0160-0575
A25C48	0160-0575	4		CAPACITOR-FXD 047UF ±20% 50VDC CER	28480	0160-0575
A25CR1	1901-0539	3	4	DIODE-SM SIG SCHOTTKY	28480	1901-0539
A25CR2	1901-0539	3		DIODE-SM SIG SCHOTTKY	28480	1901-0539
A25CR3	1901-0539	3		DIODE-SM SIG SCHOTTKY	28480	1901-0539
A25CR4	1901-0050	3	2	DIODE-SWITCHING 80V 200MA 2NS DO-35	28480	1901-0050
A25CR5	1901-0050	3		DIODE-SWITCHING 80V 200MA 2NS DO-35	28480	1901-0050
A25CR6	1901-0376	6	4	DIODE-GEN PRP 35V 50MA DO-35	28480	1901-0376
A25CR7	1901-0376	6		DIODE-GEN PRP 35V 50MA DO-35	28480	1901-0376
A25CR8	1901-0376	6		DIODE-GEN PRP 35V 50MA DO-35	28480	1901-0376
A25CR9	1901-0376	6		DIODE-GEN PRP 35V 50MA DO-35	28480	1901-0376
A25CR10	1901-0033	2	5	DIODE-GEN PRP 180V 200MA DO-7	28480	1901-0033
A25CR11	1901-0033	2		DIODE-GEN PRP 180V 200MA DO-7	28480	1901-0033
A25CR12	1901-0539	3		DIODE-SM SIG SCHOTTKY	28480	1901-0539
A25CR13	1901-0033	2		DIODE-GEN PRP 180V 200MA DO-7	28480	1901-0033
A25CR14	1901-0033	2		DIODE-GEN PRP 180V 200MA DO-7	28480	1901-0033
A25CR15	1901-0033	2		DIODE-GEN PRP 180V 200MA DO-7	28480	1901-0033
A25J1	1250-0691	7	2	CONNECTOR-RF SMB M SGL-HOLE-FR 50-OHM	28480	1250-0691
A25J2	1250-0691	7		CONNECTOR-RF SMB M SGL-HOLE-FR 50-OHM	28480	1250-0691
A25K1	0490-1409	4	1	RELAY 2C 5VDC-COIL 2A 250VAC	28480	0490-1409
A25L1	9100-3562	8	2	INDUCTOR RF-CH-MLD 4 7UH 5% 166DX 385LG	28480	9100-3562
A25L2	9100-3562	8		INDUCTOR RF-CH-MLD 4 7UH 5% 166DX 385LG	28480	9100-3562

A25 ALC Detector Circuit Description

Table A25-4. A25 ALC Detector Replaceable Parts

Reference Designation	HP Part Number	C D	Qty	Description	Mfr Code	Mfr Part Number
A25MP1	4040-0750	7	1	EXTR-PC BD RED POLYC 062-BD-THKNS	28480	4040-0750
A25MP2	4040-0753	0	1	EXTR-PC BD GRN POLYC 062-BD-THKNS	28480	4040-0753
A25MP3	1480-0073	6	2	PIN-ROLL 082-IN-DIA 25-IN-LG BE-CU	28480	1480-0073
A25MP4	08340-20184	6	1	COMPT FILTER	28480	08340-20184
A25MP5	08340-00054	7	1	COVER-FILTER	28480	08340-00054
A25MP6	0624-0227	7	8	SCREW-TPG 4-40 25-IN-LG PAN-HD-POZI STL	00000	ORDER BY DESCRIPTION
A25MP7-9				NOT ASSIGNED		
A25MP10	2190-0124	4	2	WASHER-LK INTL T NO 10 195-IN-ID	28480	2190-0124
A25MP11	2950-0078	9	2	NUT-HEX-DBL-CHAM 10-32-THD 067-IN-THK	28480	2950-0078
A25Q1	1855-0276	6	2	TRANSISTOR J-FET 2N4416A N-CHAN D-MODE	01295	2N4416A
A25Q2	1855-0276	6	2	TRANSISTOR J-FET 2N4416A N-CHAN D-MODE	01295	2N4416A
A25Q3	1854-0477	7	3	TRANSISTOR NPN 2N2222A SI TO-18 PD=500MW	04713	2N2222A
A25Q4	1853-0405	9	3	TRANSISTOR PNP SI PD=300MW FT=850MHZ	04713	2N4209
A25Q5	1854-0295	7	2	TRANSISTOR-DUAL NPN PD=400MW	28480	1854-0295
A25Q6	1853-0075	9	1	TRANSISTOR-DUAL PNP PD=400MW	28480	1853-0075
A25Q7	1854-0345	8	4	TRANSISTOR NPN 2N5179 SI TO-72 PD=200MW	04713	2N5179
A25Q8	1854-0345	8	4	TRANSISTOR NPN 2N5179 SI TO-72 PD=200MW	04713	2N5179
A25Q9	1854-0345	8	4	TRANSISTOR NPN 2N5179 SI TO-72 PD=200MW	04713	2N5179
A25Q10	1854-0477	7	2	TRANSISTOR NPN 2N2222A SI TO-18 PD=500MW	04713	2N2222A
A25Q11	1854-0477	7	2	TRANSISTOR NPN 2N2222A SI TO-18 PD=500MW	04713	2N2222A
A25Q12	1855-0235	7	2	TRANSISTOR J-FET N-CHAN D-MODE TO-52 SI	28480	1855-0235
A25Q13	1854-0546	1	2	TRANSISTOR NPN SI TO-72 PD=200MW	28480	1854-0546
A25Q14	1854-0546	1	2	TRANSISTOR NPN SI TO-72 PD=200MW	28480	1854-0546
A25Q15	1855-0235	7	2	TRANSISTOR J-FET N-CHAN D-MODE TO-52 SI	28480	1855-0235
A25Q16	1854-0295	7	2	TRANSISTOR-DUAL NPN PD=400MW	28480	1854-0295
A25Q17	1854-0475	5	2	TRANSISTOR-DUAL NPN PD=750MW	28480	1854-0475
A25Q18	1853-0451	5	2	TRANSISTOR PNP 2N3799 SI TO-18 PD=360MW	01295	2N3799
A25Q19	1853-0451	5	2	TRANSISTOR PNP 2N3799 SI TO-18 PD=360MW	01295	2N3799
A25Q20	1854-0688	2	1	TRANSISTOR-DUAL NPN TO-71	28480	1854-0688
A25Q21	1854-0475	5	2	TRANSISTOR-DUAL NPN PD=750MW	28480	1854-0475
A25Q22	1853-0269	3	1	TRANSISTOR-DUAL PNP 2N3809 PD=600MW	01295	2N3809
A25Q23	1854-0345	8	1	TRANSISTOR NPN 2N5179 SI TO-72 PD=200MW	04713	2N5179
A25Q24	1853-0281	9	1	TRANSISTOR PNP 2N2907A SI TO-18 PD=400MW	04713	2N2907A
A25Q25	1855-0414	4	1	TRANSISTOR J-FET 2N4393 N-CHAN D-MODE	04713	2N4393
A25Q26	1853-0316	1	1	TRANSISTOR-DUAL PNP PD=500MW	28480	1853-0316
A25Q27	1855-0386	9	3	TRANSISTOR J-FET 2N4392 N-CHAN D-MODE	04713	2N4392
A25Q28	1855-0386	9	3	TRANSISTOR J-FET 2N4392 N-CHAN D-MODE	04713	2N4392
A25Q29	1855-0386	9	3	TRANSISTOR J-FET 2N4392 N-CHAN D-MODE	04713	2N4392
A25Q30	1853-0405	9	3	TRANSISTOR PNP SI PD=300MW FT=850MHZ	04713	2N4209
A25Q31	1853-0405	9	3	TRANSISTOR PNP SI PD=300MW FT=850MHZ	04713	2N4209
A25Q32	1855-0646	4	2	TRANSISTOR MOSFET N-CHAN E-MODE TO-39 SI	9M011	IRFF131
A25Q33	1855-0646	4	2	TRANSISTOR MOSFET N-CHAN E-MODE TO-39 SI	9M011	IRFF131
A25R1	0698-7284	5	2	RESISTOR 100K 1% 05W F TC=0±100	24546	C3-1/8-T0-1003-F
A25R2	0698-7284	5	2	RESISTOR 100K 1% 05W F TC=0±100	24546	C3-1/8-T0-1003-F
A25R3	0698-7212	9	3	RESISTOR 100 1% 05W F TC=0±100	24546	C3-1/8-T0-100R-F
A25R4	0698-8827	4	2	RESISTOR 1M 1% 125W F TC=0±100	28480	0698-8827
A25R5	0698-7264	1	1	RESISTOR 14 7K 1% 05W F TC=0±100	24546	C3-1/8-T0-1472-F
A25R6	0698-7212	9	3	RESISTOR 100 1% 05W F TC=0±100	24546	C3-1/8-T0-100R-F
A25R7	0698-3429	2	2	RESISTOR 19 6 1% 125W F TC=0±100	03888	PME55-1/8-T0-19R6-F
A25R8	0698-0082	7	4	RESISTOR 464 1% 125W F TC=0±100	24546	C4-1/8-T0-4640-F
A25R9	0757-0280	3	4	RESISTOR 1K 1% 125W F TC=0±100	24546	C4-1/8-T0-1001-F
A25R10	0757-0420	3	2	RESISTOR 750 1% 125W F TC=0±100	24546	C4-1/8-T0-751-F
A25R11	0757-0280	3	4	RESISTOR 1K 1% 125W F TC=0±100	24546	C4-1/8-T0-1001-F
A25R12	0757-0280	3	4	RESISTOR 1K 1% 125W F TC=0±100	24546	C4-1/8-T0-1001-F
A25R13	0757-0424	7	2	RESISTOR 1 1K 1% 125W F TC=0±100	24546	C4-1/8-T0-1101-F
A25R14	0698-3154	0	3	RESISTOR 4 22K 1% 125W F TC=0±100	24546	C4-1/8-T0-4221-F
A25R15	0698-7209	4	3	RESISTOR 75 1% 05W F TC=0±100	24546	C3-1/8-T0-75R0-F
A25R16	0698-3154	0	3	RESISTOR 4 22K 1% 125W F TC=0±100	24546	C4-1/8-T0-4221-F
A25R17	0757-0424	7	2	RESISTOR 1 1K 1% 125W F TC=0±100	24546	C4-1/8-T0-1101-F
A25R18	0698-3429	2	2	RESISTOR 19 6 1% 125W F TC=0±100	03888	PME55-1/8-T0-19R6-F
A25R19	0698-7212	9	3	RESISTOR 100 1% 05W F TC=0±100	24546	C3-1/8-T0-100R-F
A25R20	0698-7209	4	3	RESISTOR 75 1% 05W F TC=0±100	24546	C3-1/8-T0-75R0-F
A25R21	0698-7209	4	3	RESISTOR 75 1% 05W F TC=0±100	24546	C3-1/8-T0-75R0-F
A25R22	0698-0083	8	3	RESISTOR 1 96K 1% 125W F TC=0±100	24546	C4-1/8-T0-1961-F
A25R23	0757-0346	2	5	RESISTOR 10 1% 125W F TC=0±100	24546	C4-1/8-T0-10R0-F
A25R24	2100-0589	6	1	RESISTOR-TRMR 10 10% C SIDE-ADJ 1-TRN	28480	2100-0589
A25R25	0698-7188	8	1	RESISTOR 10 1% 05W F TC=0±100	24546	C3-1/8-T0-10R-F
A25R26	0757-0459	8	1	RESISTOR 56 2K 1% 125W F TC=0±100	24546	C4-1/8-T0-5622-F
A25R27	0698-4461	4	1	RESISTOR 698 1% 125W F TC=0±100	24546	C4-1/8-T0-698R-F
A25R28	0698-3161	9	1	RESISTOR 38 3K 1% 125W F TC=0±100	24546	C4-1/8-T0-3832-F
A25R29	0698-6112	6	1	RESISTOR 202 25% 125W F TC=0±100	28480	0698-6112
A25R30	0757-0460	1	1	RESISTOR 61 9K 1% 125W F TC=0±100	24546	C4-1/8-T0-6192-F

A25 ALC Detector Circuit Description

Table A25-4. A25 ALC Detector Replaceable Parts

Reference Designation	HP Part Number	C	D	Qty	Description	Mfr Code	Mfr Part Number
A25R31	0698-3157	3		3	RESISTOR 19 6K 1% 125W F TC=0±100	24546	C4-1/8-T0-1962-F
A25R32	0698-3157	3			RESISTOR 19 6K 1% 125W F TC=0±100	24546	C4-1/8-T0-1962-F
A25R33	2100-1762	9		4	RESISTOR-TRMR 20K 5% WW SIDE-ADJ 1-TRN	28480	2100-1762
A25R34	2100-1762	9			RESISTOR-TRMR 20K 5% WW SIDE-ADJ 1-TRN	28480	2100-1762
A25R35	0811-3596	6		1	RESISTOR 320 2% 125W PWW TC=+5600±300	01686	R3119
A25R36	0757-0438	3		4	RESISTOR 5 11K 1% 125W F TC=0±100	24546	C4-1/8-T0-5111-F
A25R37	0698-3154	0			RESISTOR 4 22K 1% 125W F TC=0±100	24546	C4-1/8-T0-4221-F
A25R38	2100-1759	4		2	RESISTOR-TRMR 2K 5% WW SIDE-ADJ 1-TRN	28480	2100-1759
A25R39	2100-1759	4			RESISTOR-TRMR 2K 5% WW SIDE-ADJ 1-TRN	28480	2100-1759
A25R40	0757-0418	9		2	RESISTOR 619 1% 125W F TC=0±100	24546	C4-1/8-T0-619R-F
A25R41	0757-0290	5		3	RESISTOR 6 19K 1% 125W F TC=0±100	19701	MF4C1/8-T0-6191-F
A25R42	0698-6320	8		6	RESISTOR 5K 1% 125W F TC=0±25	03888	PME55-1/8-T9-5001-B
A25R43	0757-0317	7		1	RESISTOR 1 33K 1% 125W F TC=0±100	24546	C4-1/8-T0-1331-F
A25R44	0698-6320	8			RESISTOR 5K 1% 125W F TC=0±25	03888	PME55-1/8-T9-5001-B
A25R45	0698-3152	8		1	RESISTOR 3 48K 1% 125W F TC=0±100	24546	C4-1/8-T0-3481-F
A25R46	0757-0279	0		2	RESISTOR 3 16K 1% 125W F TC=0±100	24546	C4-1/8-T0-3161-F
A25R47	0698-3438	3		1	RESISTOR 147 1% 125W F TC=0±100	24546	C4-1/8-T0-147R-F
A25R48	0757-0438	3			RESISTOR 5 11K 1% 125W F TC=0±100	24546	C4-1/8-T0-5111-F
A25R49	0757-0438	3			RESISTOR 5 11K 1% 125W F TC=0±100	24546	C4-1/8-T0-5111-F
A25R50	0698-6377	5		1	RESISTOR 200 1% 125W F TC=0±25	28480	0698-6377
A25R51	0757-0199	3		3	RESISTOR 21 5K 1% 125W F TC=0±100	24546	C4-1/8-T0-2152-F
A25R52	0698-6366	2		1	RESISTOR 800 1% 125W F TC=0±25	28480	0698-6366
A25R53	0757-1094	9		2	RESISTOR 1 47K 1% 125W F TC=0±100	24546	C4-1/8-T0-1471-F
A25R54	0698-0083	8			RESISTOR 1 96K 1% 125W F TC=0±100	24546	C4-1/8-T0-1961-F
A25R55	0757-0401	0		1	RESISTOR 100 1% 125W F TC=0±100	24546	C4-1/8-T0-101-F
A25R56	0757-0428	1		2	RESISTOR 1 62K 1% 125W F TC=0±100	24546	C4-1/8-T0-1621-F
A25R57	0698-3439	4		1	RESISTOR 178 1% 125W F TC=0±100	24546	C4-1/8-T0-178R-F
A25R58	2100-3351	6		1	RESISTOR-TRMR 500 10% C SIDE-ADJ 1-TRN	28480	2100-3351
A25R59	0757-0418	9			RESISTOR 619 1% 125W F TC=0±100	24546	C4-1/8-T0-619R-F
A25R60	0698-0082	7			RESISTOR 464 1% 125W F TC=0±100	24546	C4-1/8-T0-4640-F
A25R61	0698-3157	3			RESISTOR 19 6K 1% 125W F TC=0±100	24546	C4-1/8-T0-1962-F
A25R62	0757-0200	7		1	RESISTOR 5 62K 1% 125W F TC=0±100	24546	C4-1/8-T0-5621-F
A25R63	0698-0082	7			RESISTOR 464 1% 125W F TC=0±100	24546	C4-1/8-T0-4640-F
A25R64	0811-3575	1		2	RESISTOR 3K 2% 125W TC=+5600±300	28480	0811-3575
A25R65	0698-6624	5		3	RESISTOR 2K 1% 125W F TC=0±25	28480	0698-6624
A25R66	0811-3576	2		1	RESISTOR 533 2% 125W PWW TC=+3400±300	28480	0811-3576
A25R67	0699-0793	9		2	RESISTOR 33 2K 1% 125W F TC=0±25	28480	0699-0793
A25R68	0757-0464	5		1	RESISTOR 90 9K 1% 125W F TC=0±100	24546	C4-1/8-T0-9092-F
A25R69	0698-6376	4		2	RESISTOR 200K 1% 125W F TC=0±25	19701	MF4C1/8-T9-2003-B
A25R70	0698-6376	4			RESISTOR 200K 1% 125W F TC=0±25	19701	MF4C1/8-T9-2003-B
A25R71	0698-3151	7		1	RESISTOR 2 87K 1% 125W F TC=0±100	24546	C4-1/8-T0-2871-F
A25R72	0698-3160	8		1	RESISTOR 31 6K 1% 125W F TC=0±100	24546	C4-1/8-T0-3162-F
A25R73	0757-0346	2			RESISTOR 10 1% 125W F TC=0±100	24546	C4-1/8-T0-10R0-F
A25R74	0757-0280	3			RESISTOR 1K 1% 125W F TC=0±100	24546	C4-1/8-T0-1001-F
A25R75	0698-8827	4			RESISTOR 1M 1% 125W F TC=0±100	28480	0698-8827
A25R76	0698-6624	5			RESISTOR 2K 1% 125W F TC=0±25	28480	0698-6624
A25R77	0698-6362	8		2	RESISTOR 1K 1% 125W F TC=0±25	28480	0698-6362
A25R78	0757-0346	2			RESISTOR 10 1% 125W F TC=0±100	24546	C4-1/8-T0-10R0-F
A25R79	0757-0461	2		1	RESISTOR 68 1K 1% 125W F TC=0±100	24546	C4-1/8-T0-6812-F
A25R80	2100-1762	9			RESISTOR-TRMR 20K 5% WW SIDE-ADJ 1-TRN	28480	2100-1762
A25R81	0698-6317	3		1	RESISTOR 500 1% 125W F TC=0±25	03888	PME55-1/8-T9-500R-B
A25R82	0757-0420	3			RESISTOR 750 1% 125W F TC=0±100	24546	C4-1/8-T0-751-F
A25R83	0757-0465	6		6	RESISTOR 100K 1% 125W F TC=0±100	24546	C4-1/8-T0-1003-F
A25R84	2100-1762	9			RESISTOR-TRMR 20K 5% WW SIDE-ADJ 1-TRN	28480	2100-1762
A25R85	0698-8332	6		1	RESISTOR 162 1% 125W F TC=0±50	19701	MF4C1/8-T2-162R-B
A25R86	0699-1056	9		1	RESISTOR 825 1% 125W F TC=0±25	2M627	CRB14 RO CRB25
A25R87	0757-0439	4		2	RESISTOR 6 81K 1% 125W F TC=0±100	24546	C4-1/8-T0-6811-F
A25R88	2100-0552	3		1	RESISTOR-TRMR 50 10% C SIDE-ADJ 1-TRN	28480	2100-0552
A25R89	0757-0290	5			RESISTOR 6 19K 1% 125W F TC=0±100	19701	MF4C1/8-T0-6191-F
A25R90	0757-0279	0			RESISTOR 3 16K 1% 125W F TC=0±100	24546	C4-1/8-T0-3161-F
A25R91	0757-0465	6			RESISTOR 100K 1% 125W F TC=0±100	24546	C4-1/8-T0-1003-F
A25R92	0698-6621	2		1	RESISTOR 250K 1% 125W F TC=0±25	28480	0698-6621
A25R93	0698-6782	6			RESISTOR 250 1% 125W F TC=0±25	28480	0698-6782
A25R94	0698-6362	8			RESISTOR 1K 1% 125W F TC=0±25	28480	0698-6362
A25R95	0757-0346	2			RESISTOR 10 1% 125W F TC=0±100	24546	C4-1/8-T0-10R0-F
A25R96	0757-0465	6			RESISTOR 100K 1% 125W F TC=0±100	24546	C4-1/8-T0-1003-F
A25R97	0757-0465	6			RESISTOR 100K 1% 125W F TC=0±100	24546	C4-1/8-T0-1003-F
A25R98	0757-0465	6			RESISTOR 100K 1% 125W F TC=0±100	24546	C4-1/8-T0-1003-F
A25R99	0698-6320	8			RESISTOR 5K 1% 125W F TC=0±25	03888	PME55-1/8-T9-5001-B
A25R100	0698-6624	5			RESISTOR 2K 1% 125W F TC=0±25	28480	0698-6624

A25 ALC Detector Circuit Description

Table A25-4. A25 ALC Detector Replaceable Parts

Reference Designation	HP Part Number	C D	Qty	Description	Mfr Code	Mfr Part Number
A25R101	0811-3575	1		RESISTOR 3k 2% 125W TC=+5600±300	28480	0811-3575
A25R102	0698-3136	8	1	RESISTOR 17 8k 1% 125W F TC=0±100	24546	C4-1/8-T0-1782-F
A25R103	0757-1094	9		RESISTOR 1 47k 1% 125W F TC=0±100	24546	C4-1/8-T0-1471-F
A25R104	0757-0428	1		RESISTOR 1 62k 1% 125W F TC=0±100	24546	C4-1/8-T0-1621-F
A25R105	0757-0465	6		RESISTOR 100k 1% 125W F TC=0±100	24546	C4-1/8-T0-1003-F
A25R106	0757-0441	8	1	RESISTOR 8 25k 1% 125W F TC=0±100	24546	C4-1/8-T0-8251-F
A25R107	0757-0123	3	1	RESISTOR 34 8k 1% 125W F TC=0±100	28480	0757-0123
A25R108	2100-1760	7	1	RESISTOR-TRMR 5k 5% WW SIDE-ADJ 1-TRN	28480	2100-1760
A25R109	0698-0083	8		RESISTOR 1 96k 1% 125W F TC=0±100	24546	C4-1/8-T0-1961-F
A25R110	0757-0290	5		RESISTOR 6 19k 1% 125W F TC=0±100	19701	MF4C1/8-T0-6191-F
A25R110	0757-0439	4		RESISTOR 6 81k 1% 125W F TC=0±100	24546	C4-1/8-T0-6811-F
A25R111	0757-0442	9	2	RESISTOR 10k 1% 125W F TC=0±100	24546	C4-1/8-T0-1002-F
A25R112	0757-0442	9		RESISTOR 10k 1% 125W F TC=0±100	24546	C4-1/8-T0-1002-F
A25R113	0698-5404	7	1	RESISTOR 511 25% 125W F TC=0±100	03888	PME55-1/8-T0-511R-C
A25R114	0698-8960	6	1	RESISTOR 750k 1% 125W F TC=0±100	28480	0698-8960
A25R115	0757-0438	3		RESISTOR 5 11k 1% 125W F TC=0±100	24546	C4-1/8-T0-5111-F
A25R116	0757-0199	3		RESISTOR 21 5k 1% 125W F TC=0±100	24546	C4-1/8-T0-2152-F
A25R117	0757-0440	7	1	RESISTOR 7 5k 1% 125W F TC=0±100	24546	C4-1/8-T0-7501-F
A25R118	0698-6320	8		RESISTOR 5k 1% 125W F TC=0±25	03888	PME55-1/8-T9-5001-B
A25R119	0698-8872	9	1	RESISTOR 532 25% 125W F TC=0±100	28480	0698-8872
A25R120	0699-0793	9		RESISTOR 33 2k 1% 125W F TC=0±25	28480	0699-0793
A25R121	0698-6320	8		RESISTOR 5k 1% 125W F TC=0±25	03888	PME55-1/8-T9-5001-B
A25R122	0698-6320	8		RESISTOR 5k 1% 125W F TC=0±25	03888	PME55-1/8-T9-5001-B
A25R123	0698-7449	4	1	RESISTOR 1k 1% 25W F TC=0±25	19701	MF52C1/4-T9-1001-B
A25R124	0699-2053	8	1	R 15 88 1% 10W	28480	0699-2053
A25R125	0698-6321	9	1	RESISTOR 9 9k 1% 125W F TC=0±25	03888	PME55-1/8-T9-9901-B
A25R126	0699-0642	7	1	RESISTOR 10k 1% 1W F TC=0±5	28480	0699-0642
A25R127	0698-6620	1	1	RESISTOR 150k 1% 125W F TC=0±25	28480	0698-6620
A25R128	0698-6364	0	1	RESISTOR 50 1% 125W F TC=0±25	28480	0698-6364
A25R129	0757-0199	3		RESISTOR 21 5k 1% 125W F TC=0±100	24546	C4-1/8-T0-2152-F
A25R130	0698-0082	7		RESISTOR 464 1% 125W F TC=0±100	24546	C4-1/8-T0-4640-F
A25R131	0757-0346	2		RESISTOR 10 1% 125W F TC=0±100	24546	C4-1/8-T0-10R0-F
A25TP1	0360-0535	0	8	TERMINAL-TEST POINT 330IN ABOVE	28480	0360-0535
A25TP2	0360-0535	0		TERMINAL-TEST POINT 330IN ABOVE	28480	0360-0535
A25TP3	0360-0535	0		TERMINAL-TEST POINT 330IN ABOVE	28480	0360-0535
A25TP4	0360-0535	0		TERMINAL-TEST POINT 330IN ABOVE	28480	0360-0535
A25TP5	0360-0535	0		TERMINAL-TEST POINT 330IN ABOVE	28480	0360-0535
A25TP6	0360-0535	0		TERMINAL-TEST POINT 330IN ABOVE	28480	0360-0535
A25TP7	0360-0535	0		TERMINAL-TEST POINT 330IN ABOVE	28480	0360-0535
A25TP8	0360-0535	0		TERMINAL-TEST POINT 330IN ABOVE	28480	0360-0535
A25U1	1826-0845	4	1	IC OP AMP PRCN T0-99 PKG	06665	OP-07EJ
A25U2	1826-0306	2	2	IC COMPARATOR GP QUAD 14-DIP-C PKG	27014	LM339AJ
A25U3	1826-0982	0	2	IC OP AMP LOW-NOISE 8-DIP-C PKG	28480	1826-0982
A25U4	1826-0785	1	2	IC OP AMP LOW-BIAS-H-IMPED DUAL 8-DIP-C	01295	TL072ACJG
A25U5	1826-0785	1		IC OP AMP LOW-BIAS-H-IMPED DUAL 8-DIP-C	01295	TL072ACJG
A25U6	1826-1049	2	2	IC OP AMP PRCN 8-DIP-C PKG	28480	1826-1049
A25U7	1826-0982	0		IC OP AMP LOW-NOISE 8-DIP-C PKG	28480	1826-0982
A25U8	1826-0601	0	1	IC OP AMP PRCN T0-99 PKG	06665	OP-16FJ
A25U9	1826-0306	2		IC COMPARATOR GP QUAD 14-DIP-C PKG	27014	LM339AJ
A25U10	1826-1135	7		IC OP AMP PRCN 8-DIP-C PKG	28480	1826-1135
A25U11	1826-1186	8	1	ANALOG SWITCH 4 SPST 16 - CERDIP	06665	SW-06GQ
A25W1	8159-0005	0	2	RESISTOR-ZERO OHMS 22 AWG LEAD DIA	28480	8159-0005
A25W2	8159-0005	0		RESISTOR-ZERO OHMS 22 AWG LEAD DIA	28480	8159-0005

A26 Linear Modulator Circuit Description

ASSEMBLY PURPOSE

The A26 linear modulator assembly compares the detected RF power level against the level reference voltage, and drives the RF modulators to correct any errors, closing the ALC loop and leveling the RF power. The amplitude modulation (AM) input is logged and added to the level reference on this assembly.

AM LOG CONVERTER (BLOCK A)

In this block, the front panel AM modulation input is buffered and sent to a log converter where the output is logarithmically related to the input voltage. The logger output is buffered and amplified and sent to the ALC loop integrator.

ALC LOOP INTEGRATOR (BLOCK B)

Summing Node

At the ALC loop summing node, DETOUT (the detected RF power level voltage) is summed with TCREF (the reference power level voltage). When the loop is closed and leveled, these signals are equal and opposite, canceling each other. If they do not cancel, the error current is integrated and changes the RF modulation level to correct the power level. HMRKR (the marker pulses) and the logged external AM (if enabled) are also added to the summing node.

ALC Loop Band Width

The main ALC amplifier forms an integrator with two integrating capacitors that affect the loop bandwidth. Internal leveling has a loop bandwidth of 100 kHz, with one integrating capacitor connected. Selecting external leveling connects another capacitor in parallel resulting in a loop bandwidth of 80 kHz. Other operational conditions may require additional capacitance, which further lowers the loop bandwidths (see Figure A26-1).

Maximum Voltage Levels

The negative voltage from the ALC amplifier is clamped at about -3.9V when the loop goes unlevelled; the positive voltage is clamped at about $+0.5\text{V}$.

Power Meter Leveling

When using power meter leveling, to avoid ALC overshoot due to slow power meter response times, a capacitor is placed across the clamp transistor control line to make the turn-on time at bandswitches or at the beginning of sweep very slow. Leveled ALC loop bandwidth is not affected.

Open-Loop Mode

For the open-loop mode, U8 is an inverting amplifier instead of an integrator, and the reference sensitivity is doubled to get a wide control range.

A26 Linear Modulator Circuit Description

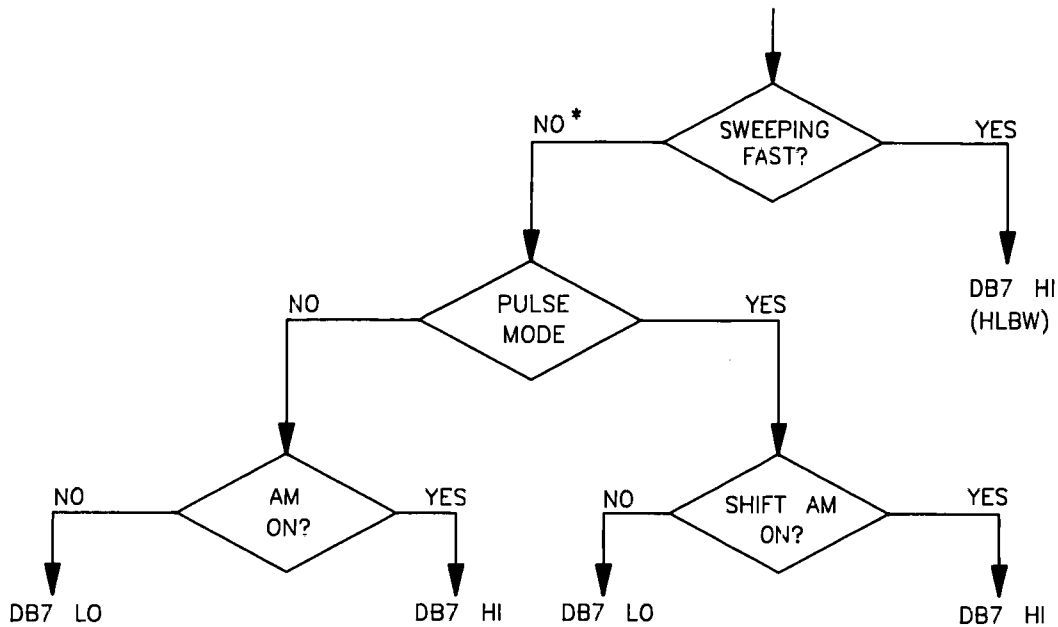

FAST SWEEP: <5 SEC

* INCLUDES MANUAL & CW

SHIFT AM ACTIVATES AM
TURNING AM OFF DE-ACTIVATES SHIFT AM

Figure A26-1. HLBW Algorithm

OVERMODULATION/UNLEVELED DETECTORS (BLOCK C)

The MODLVL (modulation level) voltage stays within certain bounds when the RF power is leveled. If MODLVL exceeds these bounds, comparators detect the condition and send the information to the microprocessor. The overmodulation/unleveled circuitry is disabled at end-of-sweep by HSP.

ALC MODULATOR SWITCH (BLOCK D)

In this block, the low band or high band RF modulators are selected to be driven by the modulator driver. Control line LB0 from the band switch driver controls FET switches that select the proper modulator.

ALC LOOP FUNCTION SWITCH DRIVERS (BLOCK E)

Digital information is latched from the microprocessor to control the major ALC functions. HMTR (high power meter) and HINT (high internal) determine the primary leveling mode. These two lines, with two decoders, drive comparators to control the main ALC amplifier. The other outputs from the latch (and the comparators) control functions for loop bandwidth, enable amplitude modulation, and enable the overmodulation/unleveled comparators.

BAND SWITCH DRIVERS (BLOCK F)

In this block, band information is decoded from control lines HLB0, HLB1, and HLB2. Each output goes low for the selected band, causing the output of the appropriate comparator to go high. The band switch drivers output control signals for the modulator switch and the modulator driver circuitry.

ALC MODULATOR DRIVER (BLOCK G)

The ALC loop gain is separately adjustable for each band (HET, X1, X2, X3, X4). Input FET switches, selected by the band switch drivers allow the MODLVL signal to pass through the proper band adjustment.

Exponential Current Source

An exponential current source drives current through the RF modulators. The exponential function linearizes the modulators' attenuation characteristics (see Figure A26-2), which is a non-linear function of drive current. RF attenuation (in dB) is proportional to the MODLVL (modulation level) voltage. In the high bands, non-linearities in the A13 SYTM power transfer characteristics require additional modulator drive shaping.

Modulator Offset

The modulator offset circuitry (MO) provides a bias current to the exponential current source input so that when MODLVL is at 0V, the exponentiator outputs a current that equals the current shunted from the modulators.

Output Buffer

An output buffer provides a high band output to the A24 SRD bias assembly for use in biasing the step recovery diode internal to the SYTM.

POWER SUPPLY (BLOCK H)

Power supply filtering consists of LC filters. The 1.5 V_F is a reference voltage for comparators.

A26 Linear Modulator Circuit Description

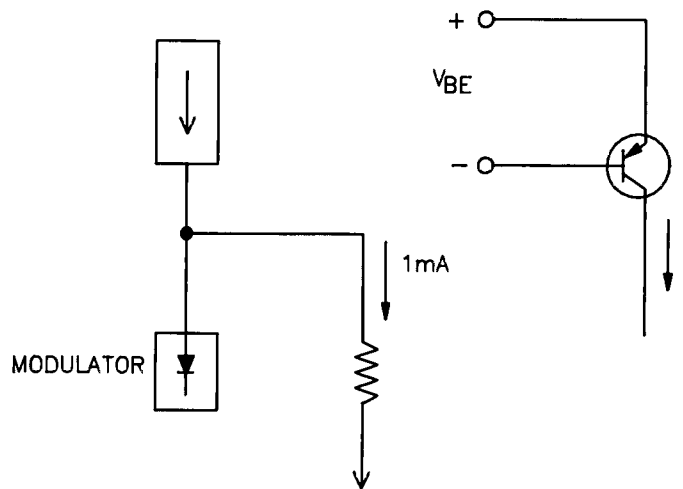
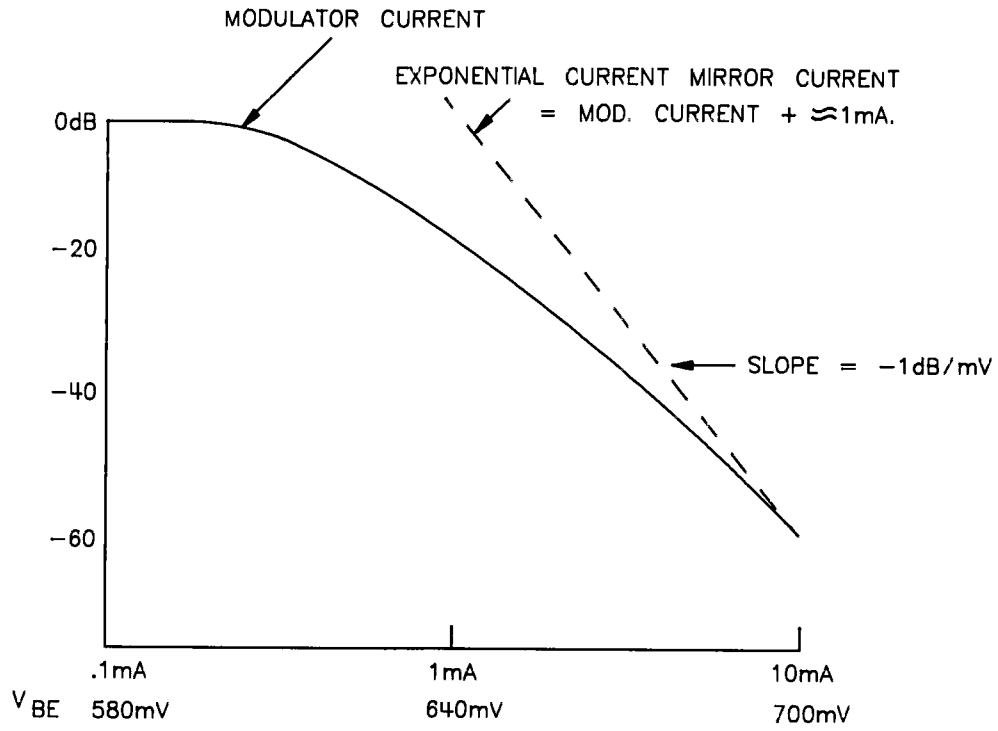

Figure A26-2. Modulator Attenuation Characteristic

A26 Linear Modulator Component-Level Troubleshooting

Table A26-1. A26 Linear Modulator Pin I/O

Pin	Mnemonic	Levels	Source	Destination
1 23	LMODHLD LHIBND	TTL TTL (LOW TRUE)	XA21P1-2 D	B A62J19 PIN 15
2 24	HPLSEN HRFON	TTL (HIGH TRUE) TTL (HIGH TRUE)	E XA57P1-105	* *B
3 25	+20V +20V	+20V +20V	XA52P1-16, 40 XA52P1-16, 40	*H *H
4 26	+5.2V +5.2V	XA52P1-17, 18, 41, 42 +5.2V	*H XA52P1-17, 18, 41, 42	*H *H
5 27	-10V -10V	-10V -10V	XA53P1-12, 13, 31, 32 XA53P1-12, 13, 31, 32	*H *H
6 28	GND GND	0V 0V	A62 STAR GND A62 STAR GND	*H *H
7 29	HSP HLB0	TTL (HIGH TRUE) TTL (HIGH TRUE)	XA57P1-13 XA27P1-46	* *F
8 30	LOMD HLB1	TTL (LOW TRUE) TTL (HIGH TRUE)	C XA27P1-16	XA27P1-48 *F
9 31	LDETBW HLB2	TTL (LOW TRUE) TTL (HIGH TRUE)	E XA27P1-47	*XA25P1-39 *F
10 32	DETOUT MODLVL	-30mV/dB, 0V = 0dBm 0V TO -3V (LEVELED)	XA25P1-32 B	B XA27P1-61
11 33	RGND HLBW	0V TTL (HIGH TRUE)	STAR GND POINT E	*H XA21P1-6
12 34	TCREF RGND	-200mV/dB, 0V = 0dBm 0V	XA25P1-35 STAR GND POINT	B *H
13 35	HMTR DB11	TTL (HIGH TRUE) TTL	E *	XA25P1-36 *E
14 36	LHET LUNLVL	TTL (LOW TRUE) TTL (LOW TRUE)	XA27P1-20 C	*NOT USED XA27P1-52
15 37	DB0 DB1	TTL TTL	XA60P1-20 XA60P1-76	*E *E
16 38	DB2 DB3	TTL TTL	XA60P1-21 XA60P1-77	*E *E
17 39	DB4 DB6	TTL TTL	XA60P1-22 XA60P1-78	*E *E
18 40	SRD BIAS CONT DB7	0 TO -5V (LEVELED) TTL	G XA60P1-79	XA24P1-13 *E
19 41	AM IN AM RTN	±1V MAXIMUM 0V	A62J15-SMC CENTER *	A A
20 42	MODHI HINT	CURRENT SOURCE TTL (HIGH TRUE)	D E	A62J13-SMC CENTER XA25P1-42
21 43	MOD RTN HMRKR	0V TTL (HIGH TRUE)	D XA57P1-2, 12	A62J13-SMC SHIELD B
22 44	MODLO WMOD	CURRENT SOURCE TTL (LOW TRUE)	D XA27P1-59	A62J14-SMC CENTER *E

A single letter in the source or destination column refers to a function block on this assembly schematic.

An asterisk (*) denotes multiple sources or destinations; refer to the A62 motherboard wiring List for a complete representation of signal sources and destinations.

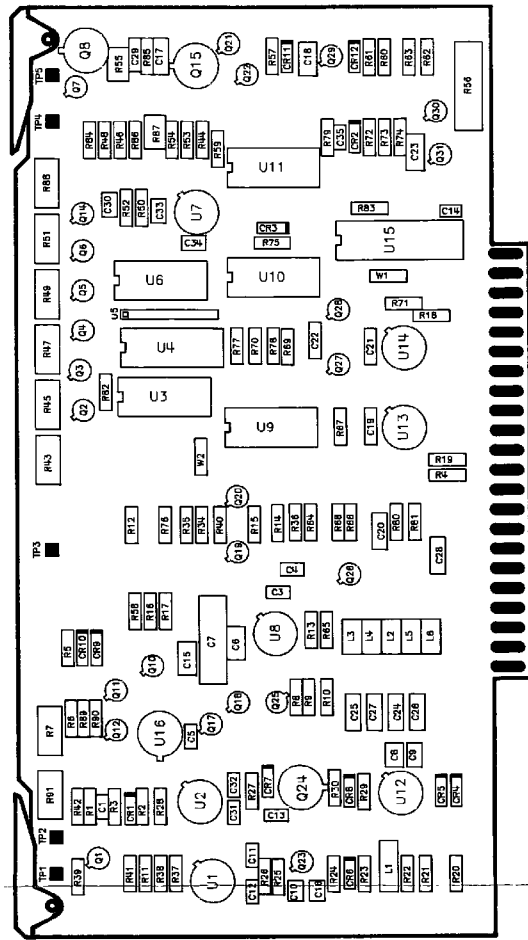

HP Part Number: 08340-60284

Figure A26-3. A26 Linear Modulator Component Location Diagram
A26-8 RF Section

A26 LINEAR MODULATOR
08340-80284

NOTES:
1. RESISTANCE VALUES ARE IN OHMS, CAPACITANCE IN MICROFARADS, UNLESS OTHERWISE NOTED.
2. MR. SYMBOLS FOR SYSTEM LEVELING UNLESS OTHERWISE NOTED.
3. MR. SYMBOLS FOR SYSTEM LEVELING UNLESS OTHERWISE NOTED.

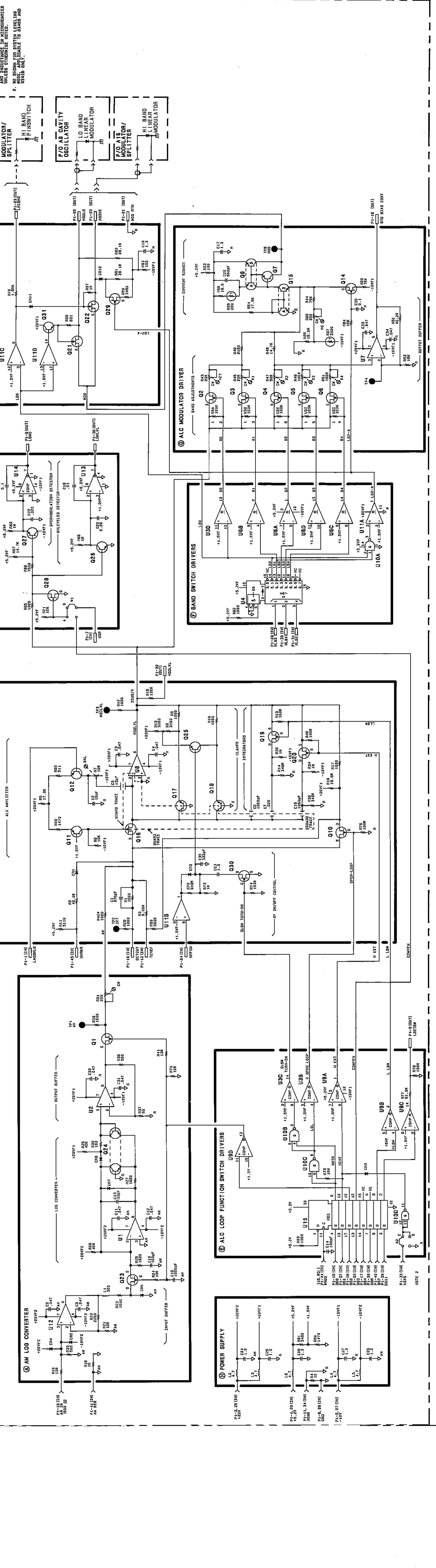

Figure A26-4. A26 Linear Modulator Schematic A26-9/A26-10 RF Section

A26 Linear Modulator Component-Level Troubleshooting

Table A26-2. A26 Linear Modulator Replaceable Parts

Reference Designation	HP Part Number	C D	Qty	Description	Mfr Code	Mfr Part Number
A26	08340-60284	1	1	LINEAR MODULATOR ASSEMBLY	28480	08340-60284
A26C1	0160-4811	9	1	CAPACITOR-FXD 270PF ±5% 100VDC CER	28480	0160-4811
A26C2	0160-4385	2	1	CAPACITOR-FXD 15PF ±5% 200VDC CER 0±30	28480	0160-4385
A26C3	0160-0575	4	10	CAPACITOR-FXD 047UF ±20% 50VDC CER	28480	0160-0575
A26C4	0160-0575	4		CAPACITOR-FXD 047UF ±20% 50VDC CER	28480	0160-0575
A26C5	0160-4793	6	1	CAPACITOR-FXD 6 8PF ± 5PF 100VDC CER	28480	0160-4793
A26C6	0160-0153	4	2	CAPACITOR-FXD 1000PF ± 10% 200VDC POLYE	28480	0160-0153
A26C7	0160-0162	5	1	CAPACITOR-FXD 022UF ± 10% 200VDC POLYE	28480	0160-0162
A26C8	0160-0575	4		CAPACITOR-FXD 047UF ± 20% 50VDC CER	28480	0160-0575
A26C9	0160-0575	4		CAPACITOR-FXD 047UF ± 20% 50VDC CER	28480	0160-0575
A26C10	0160-4389	6	2	CAPACITOR-FXD 100PF ± 5PF 200VDC CER	28480	0160-4389
A26C11	0160-0575	4		CAPACITOR-FXD 047UF ± 20% 50VDC CER	28480	0160-0575
A26C12	0160-0575	4		CAPACITOR-FXD 047UF ± 20% 50VDC CER	28480	0160-0575
A26C13	0160-4386	3	1	CAPACITOR-FXD 33PF ± 5% 200VDC CER 0±30	28480	0160-4386
A26C14	0160-4389	6		CAPACITOR-FXD 100PF ± 5PF 200VDC CER	28480	0160-4389
A26C15	0160-0153	4		CAPACITOR-FXD 1000PF ± 10% 200VDC POLYE	28480	0160-0153
A26C16	0160-3878	6	1	CAPACITOR-FXD 1000PF ± 20% 100VDC CER	28480	0160-3878
A26C17	0160-4535	4	8	CAPACITOR-FXD 1UF ± 10% 50VDC CER	28480	0160-4535
A26C18	0160-4535	4		CAPACITOR-FXD 1UF ± 10% 50VDC CER	28480	0160-4535
A26C19	0160-4835	7	2	CAPACITOR-FXD 1UF ± 10% 50VDC CER	28480	0160-4835
A26C20	0160-5098	6	2	CAPACITOR-FXD 22UF ± 10% 50VDC CER	16299	CAC05X7R224J050A
A26C21	0160-4835	7		CAPACITOR-FXD 1UF ± 10% 50VDC CER	28480	0160-4835
A26C22	0160-5098	6		CAPACITOR-FXD 22UF ± 10% 50VDC CER	16299	CAC05X7R224J050A
A26C23	0160-4535	4		CAPACITOR-FXD 1UF ± 10% 50VDC CER	28480	0160-4535
A26C24	0160-4535	4		CAPACITOR-FXD 1UF ± 10% 50VDC CER	28480	0160-4535
A26C25	0160-4535	4		CAPACITOR-FXD 1UF ± 10% 50VDC CER	28480	0160-4535
A26C26	0160-4535	4		CAPACITOR-FXD 1UF ± 10% 50VDC CER	28480	0160-4535
A26C27	0160-4535	4		CAPACITOR-FXD 1UF ± 10% 50VDC CER	28480	0160-4535
A26C28	0160-4535	4		CAPACITOR-FXD 1UF ± 10% 50VDC CER	28480	0160-4535
A26C29	0160-4825	5	1	CAPACITOR-FXD 560PF ± 5% 100VDC CER	28480	0160-4825
A26C30	0160-3879	7	1	CAPACITOR-FXD 01UF ± 20% 100VDC CER	28480	0160-3879
A26C31	0160-0575	4		CAPACITOR-FXD 047UF ± 20% 50VDC CER	28480	0160-0575
A26C32	0160-0575	4		CAPACITOR-FXD 047UF ± 20% 50VDC CER	28480	0160-0575
A26C33	0160-0575	4		CAPACITOR-FXD 047UF ± 20% 50VDC CER	28480	0160-0575
A26C34	0160-0575	4		CAPACITOR-FXD 047UF ± 20% 50VDC CER	28480	0160-0575
A26C35	0160-4810	8	1	CAPACITOR-FXD 330PF ± 5% 100VDC CER	28480	0160-4810
A26C36				NOT ASSIGNED		
A26CR1	1901-0033	2	7	DIODE-GEN PRP 180V 200MA DO-7	28480	1901-0033
A26CR2	1901-0033	2		DIODE-GEN PRP 180V 200MA DO-7	28480	1901-0033
A26CR3	1901-0539	3	5	DIODE-SM SIG SCHOTTKY	28480	1901-0539
A26CR4	1901-0033	2		DIODE-GEN PRP 180V 200MA DO-7	28480	1901-0033
A26CR5	1901-0033	2		DIODE-GEN PRP 180V 200MA DO-7	28480	1901-0033
A26CR6	1901-0033	2		DIODE-GEN PRP 180V 200MA DO-7	28480	1901-0033
A26CR7	1901-0539	3		DIODE-SM SIG SCHOTTKY	28480	1901-0539
A26CR8	1901-0539	3		DIODE-SM SIG SCHOTTKY	28480	1901-0539
A26CR9	1901-0539	3		DIODE-SM SIG SCHOTTKY	28480	1901-0539
A26CR10	1901-0539	3		DIODE-SM SIG SCHOTTKY	28480	1901-0539
A26CR11	1901-0033	2		DIODE-GEN PRP 180V 200MA DO-7	28480	1901-0033
A26CR12	1901-0033	2		DIODE-GEN PRP 180V 200MA DO-7	28480	1901-0033
A26L1	9100-1643	2	1	INDUCTOR RF-CH-MLD 300UH 5% 2DX 45LG	28480	9100-1643
A26L2	9140-0112	2	5	INDUCTOR RF-CH-MLD 4 7UH 10%	28480	9140-0112
A26L3	9140-0112	2		INDUCTOR RF-CH-MLD 4 7UH 10%	28480	9140-0112
A26L4	9140-0112	2		INDUCTOR RF-CH-MLD 4 7UH 10%	28480	9140-0112
A26L5	9140-0112	2		INDUCTOR RF-CH-MLD 4 7UH 10%	28480	9140-0112
A26L6	9140-0112	2		INDUCTOR RF-CH-MLD 4 7UH 10%	28480	9140-0112
A26MP1	1480-0073	6	2	PIN-ROLL 062-IN-DIA 25-IN-LG BE-CU	28480	1480-0073
A26MP2	4040-0750	7	1	EXTR-PC BD RED POLYC 062-BD-THKNS	28480	4040-0750
A26MP3	4040-0754	1	1	EXTR-PC BD BLU POLYC 062-BD-THKNS	28480	4040-0754
A26Q1	1855-0420	2	1	TRANSISTOR J-FET 2N4391 N-CHAN D-MODE	01295	2N4391
A26Q2	1855-0414	4	9	TRANSISTOR J-FET 2N4393 N-CHAN D-MODE	04713	2N4393
A26Q3	1855-0414	4		TRANSISTOR J-FET 2N4393 N-CHAN D-MODE	04713	2N4393
A26Q4	1855-0414	4		TRANSISTOR J-FET 2N4393 N-CHAN D-MODE	04713	2N4393
A26Q5	1855-0414	4		TRANSISTOR J-FET 2N4393 N-CHAN D-MODE	04713	2N4393
A26Q6	1855-0414	4		TRANSISTOR J-FET 2N4393 N-CHAN D-MODE	04713	2N4393
A26Q7	1853-0451	5	2	TRANSISTOR PNP 2N3799 SI TO-18 PD=360MW	01295	2N3799
A26Q8	1853-0388	7	1	TRANSISTOR-DUAL PNP PD=600MW	28480	1853-0388
A26Q9				NOT ASSIGNED		
A26Q10	1855-0414	4		TRANSISTOR J-FET 2N4393 N-CHAN D-MODE	04713	2N4393

A26 Linear Modulator Component-Level Troubleshooting

Table A26-2. A26 Linear Modulator Replaceable Parts

Reference Designation	HP Part Number	C D	Qty	Description	Mfr Code	Mfr Part Number
A26Q11	1853-0018	0	2	TRANSISTOR PNP SI TO-72 PD=200MW FT=1GHZ	28480	1853-0018
A26Q12	1853-0018	0	0	TRANSISTOR PNP SI TO-72 PD=200MW FT=1GHZ	28480	1853-0018
A26Q13				NOT ASSIGNED		
A26Q14	1855-0421	3	4	TRANSISTOR J-FET 2N5114 P-CHAN D-MODE	17856	2N5114
A26Q15	1854-0475	5	2	TRANSISTOR-DUAL NPN PD=750MW	28480	1854-0475
A26Q16	1855-0232	4	1	TRANSISTOR-JFET DUAL 2N5565 N-CHAN	04713	2N5565
A26Q17	1854-0477	7	3	TRANSISTOR NPN 2N2222A SI TO-18 PD=500MW	04713	2N2222A
A26Q18	1853-0281	9	2	TRANSISTOR PNP 2N2907A SI TO-18 PD=400MW	04713	2N2907A
A26Q19	1855-0414	4	4	TRANSISTOR J-FET 2N4393 N-CHAN D-MODE	04713	2N4393
A26Q20	1855-0414	4	4	TRANSISTOR J-FET 2N4393 N-CHAN D-MODE	04713	2N4393
A26Q21	1855-0421	3	3	TRANSISTOR J-FET 2N5114 P-CHAN D-MODE	17856	2N5114
A26Q22	1855-0421	3	3	TRANSISTOR J-FET 2N5114 P-CHAN D-MODE	17856	2N5114
A26Q23	1855-0386	9	1	TRANSISTOR J-FET 2N4392 N-CHAN D-MODE	04713	2N4392
A26Q24	1854-0475	5	5	TRANSISTOR-DUAL NPN PD=750MW	28480	1854-0475
A26Q25	1853-0451	5	5	TRANSISTOR PNP 2N3799 SI TO-18 PD=360MW	01295	2N3799
A26Q26	1854-0477	7	7	TRANSISTOR NPN 2N2222A SI TO-18 PD=500MW	04713	2N2222A
A26Q27	1853-0281	9	9	TRANSISTOR PNP 2N2907A SI TO-18 PD=400MW	04713	2N2907A
A26Q28	1855-0278	8	1	TRANSISTOR J-FET 2N5116 P-CHAN D-MODE	17856	2N5116
A26Q29	1855-0421	3	3	TRANSISTOR J-FET 2N5114 P-CHAN D-MODE	17856	2N5114
A26Q30	1855-0414	4	4	TRANSISTOR J-FET 2N4393 N-CHAN D-MODE	04713	2N4393
A26Q31	1854-0477	7	7	TRANSISTOR NPN 2N2222A SI TO-18 PD=500MW	04713	2N2222A
A26R1	0698-6362	8	2	RESISTOR 1K 1% 125W F TC=0±25	28480	0698-6362
A26R2	0698-3450	9	2	RESISTOR 42 2K 1% 125W F TC=0±100	24546	C4-1/8-T0-4222-F
A26R3	0698-8861	6	2	RESISTOR 6 66K 1% 125W F TC=0±25	28480	0698-8861
A26R4	0757-0346	2	2	RESISTOR 10 1% 125W F TC=0±100	24546	C4-1/8-T0-10R0-F
A26R5	0698-3151	7	2	RESISTOR 2 87K 1% 125W F TC=0±100	24546	C4-1/8-T0-2871-F
A26R6	0698-0084	9	2	RESISTOR 2 15K 1% 125W F TC=0±100	24546	C4-1/8-T0-2151-F
A26R7	2100-3273	1	1	RESISTOR-TRMR 2K 10% C SIDE-ADJ 1-TRN	28480	2100-3273
A26R8	0698-3151	7	7	RESISTOR 2 87K 1% 125W F TC=0±100	24546	C4-1/8-T0-2871-F
A26R9	0757-0280	3	9	RESISTOR 1K 1% 125W F TC=0±100	24546	C4-1/8-T0-1001-F
A26R10	0757-0280	3	3	RESISTOR 1K 1% 125W F TC=0±100	24546	C4-1/8-T0-1001-F
A26R11	0757-0438	3	1	RESISTOR 5 11K 1% 125W F TC=0±100	24546	C4-1/8-T0-5111-F
A26R12	0757-0280	3	3	RESISTOR 1K 1% 125W F TC=0±100	24546	C4-1/8-T0-1001-F
A26R13	0757-0279	0	1	RESISTOR 3 16K 1% 125W F TC=0±100	24546	C4-1/8-T0-3161-F
A26R14	0698-3458	7	2	RESISTOR 348K 1% 125W F TC=0±100	28480	0698-3458
A26R15	0757-0465	6	5	RESISTOR 100K 1% 125W F TC=0±100	24546	C4-1/8-T0-1003-F
A26R16	0698-3157	3	2	RESISTOR 19 6K 1% 125W F TC=0±100	24546	C4-1/8-T0-1962-F
A26R17	0757-0280	3	3	RESISTOR 1K 1% 125W F TC=0±100	24546	C4-1/8-T0-1001-F
A26R18	0757-0346	2	2	RESISTOR 10 1% 125W F TC=0±100	24546	C4-1/8-T0-10R0-F
A26R19	0698-6323	1	1	RESISTOR 100 1% 125W F TC=0±25	28480	0698-6323
A26R20	0698-6317	3	2	RESISTOR 500 1% 125W F TC=0±25	03888	PME55-1/8-T9-500R-B
A26R21	0698-6360	6	1	RESISTOR 10K 1% 125W F TC=0±25	28480	0698-6360
A26R22	0698-4433	0	1	RESISTOR 2 26K 1% 125W F TC=0±100	24546	C4-1/8-T0-2261-F
A26R23	0698-6624	5	1	RESISTOR 2K 1% 125W F TC=0±25	28480	0698-6624
A26R24	0757-0442	9	7	RESISTOR 10K 1% 125W F TC=0±100	24546	C4-1/8-T0-1002-F
A26R25	0757-0428	1	2	RESISTOR 1 62K 1% 125W F TC=0±100	24546	C4-1/8-T0-1621-F
A26R26	0698-6363	9	2	RESISTOR 40K 1% 125W F TC=0±25	28480	0698-6363
A26R27	0757-0428	1	1	RESISTOR 1 62K 1% 125W F TC=0±100	24546	C4-1/8-T0-1621-F
A26R28	0757-0280	3	3	RESISTOR 1K 1% 125W F TC=0±100	24546	C4-1/8-T0-1001-F
A26R29	0698-6363	9	9	RESISTOR 40K 1% 125W F TC=0±25	28480	0698-6363
A26R30	0757-0401	0	4	RESISTOR 100 1% 125W F TC=0±100	24546	C4-1/8-T0-101-F
A26R31				NOT ASSIGNED		
A26R32				NOT ASSIGNED		
A26R33	0757-0442	9	9	RESISTOR 10K 1% 125W F TC=0±100	24546	C4-1/8-T0-1002-F
A26R34	0698-8827	4	6	RESISTOR 1M 1% 125W F TC=0±100	28480	0698-8827
A26R35	0698-3458	7	7	RESISTOR 348K 1% 125W F TC=0±100	28480	0698-3458
A26R36	0698-8827	4	4	RESISTOR 1M 1% 125W F TC=0±100	28480	0698-8827
A26R37	0698-6364	0	1	RESISTOR 50 1% 125W F TC=0±25	28480	0698-6364
A26R38	0698-6317	3	3	RESISTOR 500 1% 125W F TC=0±25	03888	PME55-1/8-T9-500R-B
A26R39				NOT ASSIGNED		
A26R40	0757-0465	6	6	RESISTOR 100K 1% 125W F TC=0±100	24546	C4-1/8-T0-1003-F
A26R41	0757-0442	9	9	RESISTOR 10K 1% 125W F TC=0±100	24546	C4-1/8-T0-1002-F
A26R42	0698-6362	8	8	RESISTOR 1K 1% 125W F TC=0±25	28480	0698-6362
A26R43	2100-3353	8	3	RESISTOR-TRMR 20K 10% C SIDE-ADJ 1-TRN	28480	2100-3353
A26R44	0757-0462	3	2	RESISTOR 75K 1% 125W F TC=0±100	24546	C4-1/8-T0-7502-F
A26R45	2100-3353	8	8	RESISTOR-TRMR 20K 10% C SIDE-ADJ 1-TRN	28480	2100-3353
A26R46	0698-0084	9	9	RESISTOR 2 15K 1% 125W F TC=0±100	24546	C4-1/8-T0-2151-F
A26R47	2100-3354	9	1	RESISTOR-TRMR 50K 10% C SIDE-ADJ 1-TRN	28480	2100-3354
A26R48	0698-3156	2	2	RESISTOR 14 7K 1% 125W F TC=0±100	24546	C4-1/8-T0-1472-F
A26R49	2100-3355	0	2	RESISTOR-TRMR 100K 10% C SIDE-ADJ 1-TRN	28480	2100-3355
A26R50	0698-3450	9	9	RESISTOR 42 2K 1% 125W F TC=0±100	24546	C4-1/8-T0-4222-F

A26 Linear Modulator Component-Level Troubleshooting

Table A26-2. A26 Linear Modulator Replaceable Parts

Reference Designation	HP Part Number	C D	Qty	Description	Mfr Code	Mfr Part Number
A26R51	2100-3355	0		RESISTOR-TRMR 100k 10% C SIDE-ADJ 1-TRN	28480	2100-3355
A26R52	0757-0442	9		RESISTOR 10k 1% 125W F TC=0±100	24546	C4-1/8-T0-1002-F
A26R53	0757-0401	0		RESISTOR 100 1% 125W F TC=0±100	24546	C4-1/8-T0-101-F
A26R54	0698-3136	8	1	RESISTOR 17 8k 1% 125W F TC=0±100	24546	C4-1/8-T0-1782-F
A26R55	0811-3619	4	1	RESISTOR 260 2% 125W PWW TC=+3400±300	01686	R3129
A26R56	0757-0816	1	1	RESISTOR 681 1% 5W F TC=0±100	28480	0757-0816
A26R57	0698-8827	4		RESISTOR 1M 1% 125W F TC=0±100	28480	0698-8827
A26R58	0698-8861	6		RESISTOR 6 66k 1% 125W F TC=0±25	28480	0698-8861
A26R59	0757-0462	3		RESISTOR 75k 1% 125W F TC=0±100	24546	C4-1/8-T0-7502-F
A26R60	0698-3152	8	2	RESISTOR 3.48k 1% 125W F TC=0±100	24546	C4-1/8-T0-3481-F
A26R61	0698-3159	5	2	RESISTOR 26 1k 1% 125W F TC=0±100	24546	C4-1/8-T0-2612-F
A26R62	0698-3159	5		RESISTOR 26 1k 1% 125W F TC=0±100	24546	C4-1/8-T0-2612-F
A26R63	0757-0401	0		RESISTOR 100 1% 125W F TC=0±100	24546	C4-1/8-T0-101-F
A26R64	0757-0280	3		RESISTOR 1k 1% 125W F TC=0±100	24546	C4-1/8-T0-1001-F
A26R65	0757-0280	3		RESISTOR 1k 1% 125W F TC=0±100	24546	C4-1/8-T0-1001-F
A26R66	0757-0440	7	1	RESISTOR 7 5k 1% 125W F TC=0±100	24546	C4-1/8-T0-7501-F
A26R67	0698-3156	2		RESISTOR 14 7k 1% 125W F TC=0±100	24546	C4-1/8-T0-1472-F
A26R68	0698-8827	4		RESISTOR 1M 1% 125W F TC=0±100	28480	0698-8827
A26R69	0698-8827	4		RESISTOR 1M 1% 125W F TC=0±100	28480	0698-8827
A26R70	0757-0442	9		RESISTOR 10k 1% 125W F TC=0±100	24546	C4-1/8-T0-1002-F
A26R71	0757-0442	9		RESISTOR 10k 1% 125W F TC=0±100	24546	C4-1/8-T0-1002-F
A26R72	0698-8959	3	1	RESISTOR 619k 1% 125W F TC=0±100	28480	0698-8959
A26R73	0698-8827	4		RESISTOR 1M 1% 125W F TC=0±100	28480	0698-8827
A26R74	0757-0465	6		RESISTOR 100k 1% 125W F TC=0±100	24546	C4-1/8-T0-1003-F
A26R75	0757-0442	9		RESISTOR 10k 1% 125W F TC=0±100	24546	C4-1/8-T0-1002-F
A26R76	0757-0465	6		RESISTOR 100k 1% 125W F TC=0±100	24546	C4-1/8-T0-1003-F
A26R77	0757-0460	1	1	RESISTOR 61 9k 1% 125W F TC=0±100	24546	C4-1/8-T0-6192-F
A26R78	0757-0465	6		RESISTOR 100k 1% 125W F TC=0±100	24546	C4-1/8-T0-1003-F
A26R79	0698-0083	8	1	RESISTOR 1 96k 1% 125W F TC=0±100	24546	C4-1/8-T0-1961-F
A26R80	0757-1094	9	1	RESISTOR 1 47k 1% 125W F TC=0±100	24546	C4-1/8-T0-1471-F
A26R81	0698-3152	8		RESISTOR 3 48k 1% 125W F TC=0±100	24546	C4-1/8-T0-3481-F
A26R82	0757-0280	3		RESISTOR 1k 1% 125W F TC=0±100	24546	C4-1/8-T0-1001-F
A26R83	0757-0280	3		RESISTOR 1k 1% 125W F TC=0±100	24546	C4-1/8-T0-1001-F
A26R84	0757-0442	9		RESISTOR 10k 1% 125W F TC=0±100	24546	C4-1/8-T0-1002-F
A26R85	0698-3429	2	1	RESISTOR 19 6 1% 125W F TC=0±100	03888	PME55-1/8-T0-19R6-F
A26R86	0698-3157	3		RESISTOR 19 6k 1% 125W F TC=0±100	24546	C4-1/8-T0-1962-F
A26R87	0811-3575	1	1	RESISTOR 3k 2% 125W TC=+5600±300	28480	0811-3575
A26R88	2100-3353	8		RESISTOR-TRMR 20k 10% C SIDE-ADJ 1-TRN	28480	2100-3353
A26R89	0757-0401	0		RESISTOR 100 1% 125W F TC=0±100	24546	C4-1/8-T0-101-F
A26R90	0757-0402	1	1	RESISTOR 110 1% 125W F TC=0±100	24546	C4-1/8-T0-111-F
A26R91	2100-3350	5	1	RESISTOR-TRMR 200 10% C SIDE-ADJ 1-TRN	28480	2100-3350
A26TP1	0360-0535	0	5	TERMINAL-TEST POINT 330IN ABOVE	28480	0360-0535
A26TP2	0360-0535	0		TERMINAL-TEST POINT 330IN ABOVE	28480	0360-0535
A26TP3	0360-0535	0		TERMINAL-TEST POINT 330IN ABOVE	28480	0360-0535
A26TP4	0360-0535	0		TERMINAL-TEST POINT 330IN ABOVE	28480	0360-0535
A26TP5	0360-0535	0		TERMINAL-TEST POINT 330IN ABOVE	28480	0360-0535
A26U1	1826-0601	0	3	IC OP AMP PRCN TO-99 PKG	06665	OP-16FJ
A26U2	1826-1007	2	1	IC OP AMP PRCN 8-TO-99 PKG	28480	1826-1007
A26U3	1826-0306	2	3	IC COMPARATOR GP QUAD 14-DIP-C PKG	27014	LM339AJ
A26U4	1820-1216	3	1	IC DCOR TTL LS 3-TO-8-LINE 3-INP	01295	SN74LS138N
A26U5	1810-0371	8	1	NETWORK-RES 8-SIP100 0K OHM X 7	01121	208A104
A26U6	1826-0306	2		IC COMPARATOR GP QUAD 14-DIP-C PKG	27014	LM339AJ
A26U7	1826-0828	3	1	IC OP AMP PRCN TO-99 PKG	06665	OP-15GJ
A26U8	1826-0601	0		IC OP AMP PRCN TO-99 PKG	06665	OP-16FJ
A26U9	1826-0306	2		IC COMPARATOR GP QUAD 14-DIP-C PKG	27014	LM339AJ
A26U10	1820-1197	9	1	IC GATE TTL LS NAND QUAD 2-INP	01295	SN74LS00N
A26U11	1826-0161	7	1	IC OP AMP GP QUAD 14-DIP-P PKG	04713	MLM324P
A26U12	1826-0601	0		IC OP AMP PRCN TO-99 PKG	06665	OP-16FJ
A26U13	1826-0026	3	2	IC COMPARATOR PRCN TO-99 PKG	01295	LM311L
A26U14	1826-0026	3		IC COMPARATOR PRCN TO-99 PKG	01295	LM311L
A26U15	1820-1730	6	1	IC FF TTL LS D-TYPE POS-EDGE-TRIG COM	01295	SN74LS273N
A26W1	8159-0005	0	2	RESISTOR-ZERO OHMS 22 AWG LEAD DIA	28480	8159-0005
A26W2	8159-0005	0		RESISTOR-ZERO OHMS 22 AWG LEAD DIA	28480	8159-0005

A27 Level Control Circuit Description

ASSEMBLY PURPOSE

The A27 level control assembly performs the following functions:

- Flatness compensation – provides error compensation to the ALC loop control as a function of frequency.
- Power sweep control – uses the RF sweep to generate a microprocessor controlled power level sweep.
- Test ADC (analog-to-digital-converter) – monitors any one of several dc levels via an analog multiplexer. The ADC sends a digital equivalent of the chosen dc voltage to the microprocessor.

BAND SWITCH CONTROL (BLOCK A)

Bits 0, 1, and 2 are latched off of the data bus on the rising edge of strobe WBAND (band information I/O). These bits produce the encoded latched band information HLB0, HLB1, and HLB2

LHET (low heterodyne) is decoded from the inverted outputs of HLB1 and HLB2. LHET is high when either of the inverted HLB1 or HLB2 outputs are low.

ADDRESS DECODING (BLOCK B)

I/O strobe decoding consists of two 3-to-8-line decoders and one NAND gate connected as an inverter. The two decoders decode address lines A0 through A4, and SIOA I/O strobe, to produce input and output strobes for the RF section.

20 GHZ BREAKPOINT SLOPE COMPENSATION (BLOCK C)

The 20 GHz breakpoint is used to compensate for directional coupler forward losses, and detector losses that occur beyond 20 GHz. This breakpoint occurs when the voltage on the -0.25 V/GHz line is -5.0 V.

This block has a gain of -2.0 , for an output of 0.00 to 0.5 V/GHz, depending on the DAC input.

9 GHZ BREAKPOINT SLOPE COMPENSATION (BLOCK D)

The 9 GHz breakpoint is used to compensate for detector losses. This breakpoint occurs when the voltage on the -0.25 V/GHz line is -2.25 V.

This block has a gain of -1.0 , for an output of 0.00 to 0.25 V/GHz, depending on the DAC input.

ATTENUATOR SLOPE COMPENSATION (BLOCK E)

Attenuator slope compensation increases or decreases the level reference voltage as a function of frequency. When this reference increases, it causes the leveling circuitry to increase the output power as a function of frequency, to compensate for power losses in the attenuator or cabling between the detector coupler and the instrument output.

In low band, the slope circuitry compensates for the frequency response of the low band detector. Because the detector can have either a positive or negative slope versus frequency, this compensation circuit is bipolar.

The rate at which the output power increases is determined by a constant written into the attenuator slope compensation DAC, which is different for each RF attenuator step, because the frequency response is different for each step.

-0.25 V/GHz from the A28 SYTM driver assembly is the frequency reference for this circuit. With a gain of -0.83 , this block has an output of 0.00 to 0.21 V/GHz, depending on the DAC input.

COMPENSATION SUMMING AMPLIFIER (BLOCK F)

The inverting summing amplifier sums four compensation terms with correct polarity and gain:

- 20 GHz Breakpoint Slope Compensation
- 9 GHz Breakpoint Slope Compensation
- Attenuator Slope Compensation
- Cable Slope Compensation

At the output, the correction voltage has a value of $0V = 0$ dBm, with a correction factor of 1.25 dB/V.

CABLE SLOPE COMPENSATION (BLOCK G)

This block provides temperature compensation for front panel output options that have a short cable length. The compensation at 25°C is approximately 0.0027 dB/GHz.

In rear panel options, which have a long cable, R71 is removed and R70 is replaced with a short to provide 0.0052 dB/GHz compensation at 25°C .

Because the resistance of RT1 decreases with temperature, the amount of compensation increases with temperature.

ALC REFERENCE GENERATOR (BLOCK H)

A 10-bit multiplying DAC controls the reference voltage for the level control circuits. For accuracy, a precision $+10.00V$ reference in the power supply circuitry provides a temperature compensated reference voltage to the DAC. From this $10.00V$ reference, the DAC creates a current that is a function of the 10-bit digital input. The digital inputs are latched off the instrument data bus by two latches. The latched outputs are pulled to a $+5V$ reference.

The output of this block is a voltage between 0 and $-10V$.

POWER SWEEP GENERATOR (BLOCK I)

The level sweep DAC provides the power sweep function by sweeping the level reference as a function of the sweep ramp.

The reference voltage for the level sweep DAC is the RF sweep ramp, which varies linearly between 0 and +10V, as the frequency sweeps between the start and stop frequencies.

REFERENCE LEVEL SUMMING AMPLIFIER (BLOCK J)

The ALC reference level DAC output, and the power sweep level DAC output are summed at unity gain. The +10.00V reference is also summed in this block, with a gain of 0.5, to provide a –5V offset at the level reference output. The output can be adjusted by the main level DAC between approximately –5.12 and +5.11V. This voltage represents a change in output power of +25.55 to –25.60 dBm, and represents a slope of approximately –0.2 V/dB. The exact slope and offset are corrected in software by the instrument controller.

FAIL TEST LED (BLOCK K)

The fail test LED indicates when an error condition is detected on the level control assembly during self test. The microprocessor turns this LED on and off.

ADC CONTROL LATCH (BLOCK L)

Six control signals are latched off the data bus when the WADCC (ADC control) strobe goes low:

- L CONVERT ALWAYS
- L DON'T CONVERT
- LA MUX0
- LA MUX1
- LA MUX2
- H SRQ DISABLE

ADC CLOCK/CONTROL (BLOCK M)

The ADC clock is generated by a schmitt trigger input NAND gate with RC feedback. The clock is controlled by several digital signals. When one of the control signals is low, the clock is disabled and its output is high. After a period of time, the feedback input is also high. If the clock circuit is enabled by all the clock control signals going high, the output goes low. The feedback input moves towards 0V at a rate determined by the RC time constant of R21 and C32. When this voltage reaches the NAND gate trigger threshold, the clock output goes high. The feedback input moves towards Vout at a rate determined by the RC time constant. When this voltage reaches the NAND gate trigger threshold, the clock output goes low, and the cycle repeats until one of the control lines goes low.

The clock circuit is disabled when the ADC is being read. When L CONVERT ALWAYS is low the clock is enabled. The clock is disabled when the conversion complete latch resets.

ADC INPUT MULTIPLEXER (BLOCK N)

The ADC input multiplexer allows the microprocessor to select which analog input line the ADC will convert to digital information for use by the microprocessor.

The ADC latch control signals determine the channel selected. The multiplexer output is connected to a buffer amplifier summing node, allowing each channel to have a different gain and offset.

Channel 0 (the DET LVL input) is bipolar, with a gain of one that yields a full scale input range of $\pm 5.0\text{V}$. The scale factor of this voltage is -0.2 V/dB , or $\pm 25\text{ dB}$ full scale.

Channels 1 through 7 are voltages that the microprocessor can use to determine that major portions of the instrument are functioning correctly.

If the microprocessor peaks the SYTM, so that more power is available, MOD LVL changes proportionally. If less power is available, this voltage changes in the opposite direction. MOD LVL provides feedback to the microprocessor for auto-peaking and auto-tracking.

TEST ADC (BLOCK O)

Test ADC measures the voltage of a preselected line and converts that voltage to digital information. Reading the output of the test ADC, the microprocessor monitors the voltage of the selected line.

Example:

The synthesizer normally places the power level that you select in the front panel ENTRY and POWER dBm displays. Under the conditions listed below, the power level you select may not be the same as the actual power output.

- When the RF power output is unlevelled.
- When the instrument is in the external leveling mode.
- When AM is on (a dc voltage on the AM input causes a change in the actual RF output power)

When any of the conditions above happen, the test ADC monitors the DETLVL input from the ALC circuitry and converts it to digital information. The microprocessor reads the information and converts it to an equivalent power level (dBm). This value appears in the front panel POWER dBm display.

The tracking analog-to-digital converter contains:

- A D-to-A converter and reference amplifier
- An up/down counter
- A window comparator (controls the up/down counter)
- Data latches (to store conversion data)

A reference current (derived from the precision 10.00V reference), is multiplied by four in the ADC and divided as required for the digital output of the internal 10-bit up/down counter.

The voltage range from the ADC input multiplexer -5 to $+5\text{V}$. -5V yields a digital value of 0, $0\text{V} = 512$, and $+5\text{V} = 1023$.

When the data hold line is high, digital information appears at the outputs of the tracking ADC. If the data hold line is brought low, the information present at the ADC and at the up/down counters is frozen in the output latch/buffers. When the microprocessor is ready for the ADC data, the RLEVEL strobe goes low, enabling the bus buffer outputs, placing the ADC data on the instrument data bus, to be read by the microprocessor.

The RLEVEL strobe is also connected to the data hold on the ADC, so that the information in the ADC latches cannot be changed while it is read. The ADC requires that the data hold line cannot be brought low for 150 ns after the rising edge of the ADC clock, to allow settling of the counter outputs. The ADC clock cannot run while the ADC is read.

Attenuator Sensing

A line connected to the input of DB10 of the ADC data output buffers is grounded when the attenuator is installed in the instrument. This bit is read when the microprocessor does a read level operation. This information is used to determine if the attenuator is installed only if the calibration data is damaged and the default values must be used.

ADC WINDOW COMPARATOR (BLOCK P)

Because the ADC clock must not run when the voltage into the ADC is not changing, an external window comparator (in addition to the window comparator internal to the test ADC) senses when to turn on the ADC clock, allowing the ADC to function.

The window comparator senses the summing node of the current DAC internal to the test ADC, and the input current through the test ADC sense resistor. When the input current does not match the current output from the ADC, an offset voltage proportional to the error between the two currents exists. Both the internal window comparator and the external window comparator sense this voltage. The external comparator triggers when this voltage exceeds approximately ± 1 LSB of the ADC. This comparator then begins a conversion. The ADC clock is turned off until the input voltage changes by more than approximately 2 LSB maximum.

A low offset operational amplifier provides a gain of approximately 20, to provide a larger voltage representing one LSB to the comparators. A filter prevents transients or noise generated by the clock circuit from triggering the comparators when the voltage is within the window. To provide a significant increase in resolution, the input buffer must have an input offset voltage much lower than the comparator input offset voltage.

CONVERSION COMPLETE TIMER/SRQ LATCH (BLOCK Q)

The conversion-complete timer allows the clock to run for eight clock pulses after the window comparator signals that the ADC has converted the input voltage to within ± 1 LSB of the actual value. This allows the ADC time to convert the input voltage to within ± 0.5 LSB before its clock is stopped (assuming the input voltage is not changing).

The window comparator output (L OUTSIDE WINDOW) is inverted to drive low enable of the counter. The counter is enabled to count up when the voltage converted is inside the window. After eight counts, the carry out goes low and clocks both the ADC clock control flip-flop (block M), and the SRQ latch. The ADC clock control flip-flop D input (block M) is grounded so it resets, turning the clock off.

The SRQ latch input comes from H SRQ DISABLE (block L). If H SRQ DISABLE is low, the SRQ latch is reset. The output of this latch goes to the status buffer (block R), to be read by the microprocessor, and to an SRQ delay circuit. The SRQ delay circuit allows only one A-D SRQ every 100 ms, to limit the microprocessor time devoted to servicing the ADC. LA-D SRQ also goes to the ADC clock/control circuitry (block M), which disables the ADC clock until the SRQ is cleared by the RLEVEL strobe.

In the delay circuit, an input transistor conducts when the ADC is not requesting service. When A-D SRQ goes low, the transistor turns off, charging an output capacitor until the voltage at the input of an OR gate causes its output (LCHNG) to go low. This signals the microprocessor that a change has occurred. When the microprocessor reads the ADC, the SRQ latch is set so its output goes high, the transistor again turns on, pulling the input to the OR gate low, the output high.

The change detectors output a low going pulse on the LCHNG line to the digital interface assembly, to indicate a change on the unlevelled or overmod inputs to the level control assembly.

The inputs (LUNLVL and LOMD) also go to an output status buffer (block R) that can be read by the processor to determine what signal has changed state.

STATUS BUFFER (BLOCK R)

Several bits of information about level control assembly functions must be communicated to the instrument processor, and several ADC control lines must be asserted by the microprocessor

A bus buffer puts several bits of information on the data bus when the RSTAT strobe goes low (block B). Four signals are communicated to the processor.

- LA-D SRQ
- LUNLVL
- LOMD
- LOW BD INSTALLED

POWER SUPPLIES (BLOCK S)

There is standard power supply filtering on the +20, +5, -5, -10, and -15V supplies to prevent noise propagation. There are also a +15 and +10V regulated supplies, derived from the +20 VDC supply.

A low current +10V supply is tied to the +5.2V supply to prevent the digital inputs to the DACs from being greater than the V_{dd} supply when the instrument is turned on.

The +10V precision reference is the reference voltage for the level DAC (block H), and produces precision offsets for the breakpoint and attenuator compensation circuits.

A27 Level Control Component-Level Troubleshooting

Table A27-1. A27 Control P1 Pin I/O (1 of 2)

Pin	Mnemonic	Levels	Source	Destination
1 32	-5.2V -5.2V	-5.2V -5.2V	XA53P1-18, 36 XA53P1-18, 36	*S *S
2 33	+20V +20V	+20V +20V	XA52P1-16, 40 XA52P1-16, 40	*S *S
3 34	+5.2V +5.2V	+5.2V +5.2V	XA52P1-17, 18, 41, 42 XA52P1-17, 18, 41, 42	*S *S
4 35	-10V -10V	-10V -10V	XA53P1-12, 13, 31, 32 XA53P1-12, 13, 31, 32	*S *S
5 36	-15V -15V	-15V -15V	XA56P1-15, 30 XA56P1-15, 30	*S *S
6 37	GND GND	0V 0V	A62 STAR GND A62 STAR GND	*S *S
7 38	GND PLANE GND PLANE	0V 0V	IN GROUND IN GROUND	*S *S
8 39	HADCEN LATN	TTL (HIGH TRUE) TTL (LOW TRUE)	XA21P1-1 A62J20-14	M O
9 40	ADR0 ADR1	TTL TTL	XA60P1-17 XA60P1-73	*B *B
10 41	ADR2 ADR3	TTL TTL	XA60P1-18 XA60P1-74	*B *B
11 42	ADR4 SIOA	TTL TTL (LOW TRUE)	XA60P1-19 XA60P1-15	*B *B
12 43	WLEVEL WBAND	TTL (LOW TRUE) TTL (LOW TRUE)	B B	XA24P1-33 XA28P1-29
13 44	WYTMSLP	TTL (LOW TRUE)	B	XA28P1-30
14 45	WYTMCTL RSTAT	TTL (LOW TRUE) TTL (LOW TRUE)	B B	XA28P1-8 *
15 46	W11R2 HLBO	TTL (LOW TRUE) TTL (HIGH TRUE)	B A	XA23P1-15 *
16 47	HLB1 HLB2	TTL (HIGH TRUE) TTL (HIGH TRUE)	A A	* *

A single letter in the source or destination column refers to a function block on this assembly schematic.

An asterisk (*) denotes multiple sources or destinations; refer to the A62 motherboard wiring list for a complete representation of signal sources and destinations.

A27 Level Control Component-Level Troubleshooting

Table A27-1. A27 Control P1 Pin I/O (2 of 2)

Pin	Mnemonic	Levels	Source	Destination
17 48	RFSWP LOMD	10V/SWEEP TTL (LOW TRUE)	XA57P1-42 XA26P1-8	I Q R
18 49	RGND RGND	0V 0V	STAR GND POINT STAR GND POINT	*S *S
19 50	GND PLANE GND PLANE	0V 0V	INSTRUMENT GROUND INSTRUMENT GROUND	*S *S
20 51	LHET — .25V/GHZ	TTL (LOW TRUE) — .25V/GHZ	A XA28P1-40	* *
21 52	LCHNG LUNLVL	TTL (LOW TRUE) TTL (LOW TRUE)	* XA26P1-36	Q Q R
22 53	DB0 DB1	TTL TTL	*XA60P1-20 *XA60P1-76	*L *L
23 54	DB2 DB3	TTL TTL	*XA60P1-21 *XA60P1-77	*L *L
24 55	DB4 DB5	TTL TTL	*XA60P1-22 *XA60P1-78	*L *L
25 56	DB6 DB7	TTL TTL	*XA60P1-23 *XA60P1-79	*L *L
26 57	DB8 DB9	TTL TTL	*XA60P1-24 *XA60P1-80	*L *L
27 58	DB10 DB11	TTL TTL	*XA60P1-25 *XA60P1-81	*L *L
28 59	RGND WMOD	0V TTL (LOW TRUE)	STAR GND POINT B	*S *
29 60	DETVL RGND	—0.2V/dB, 0V=0dB 0V	XA25P1-33 STAR GND POINT	N *S
30 61	LVLREF MODLVL	0.2V/dB, 0V=0dB 0 TO —3V LEVELED	T XA26P1-32	XA25P1-13 N
31 62	BVSWP LVLCOR	10V SWEEP 1.25 dB/V, 0V=0dB	XA58P1-40 G	N XA25P1-14

A single letter in the source or destination column refers to a function block on this assembly schematic.

An asterisk (*) denotes multiple sources or destinations; refer to the A62 motherboard wiring list for a complete representation of signal sources and destinations

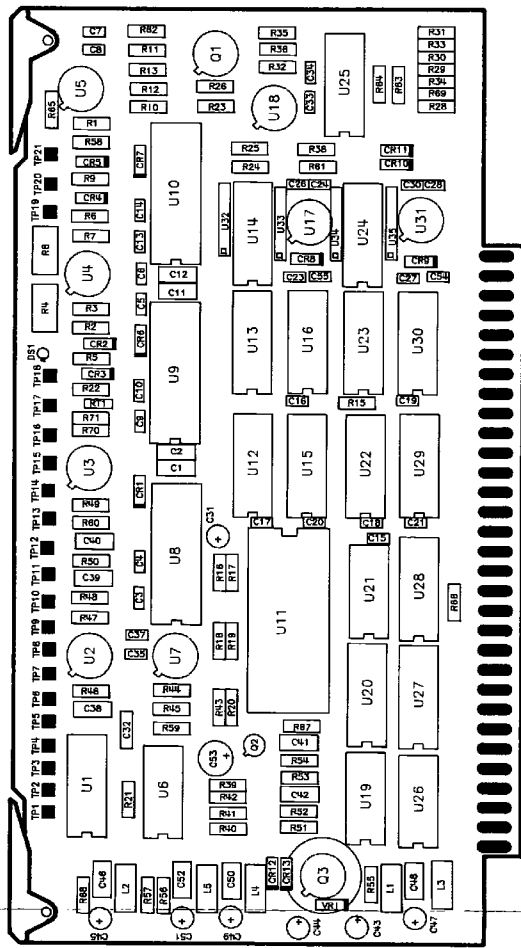

HP Part Number: 08340-60237

Figure A27-1. A27 Level Control Component Location Diagram
A27-10 RF Section

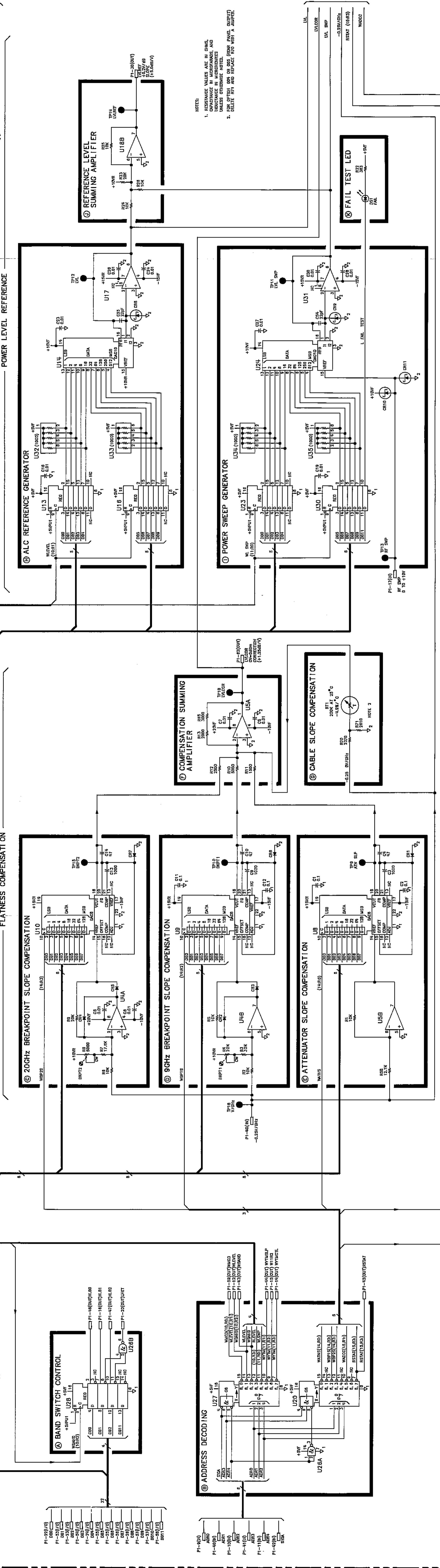

NOTES
1. RESISTANCE VALUES ARE IN OHMS, CAPACITANCE IN MICROFARADS, AND INDUCTANCE IN MICROHENRIES UNLESS OTHERWISE NOTED.
2. FOR OPTION 004 ON 005 (REAR PANEL OUTPUT) DELETE R17 AND REPLACE R70 WITH A WAFER.

POWER SUPPLIES

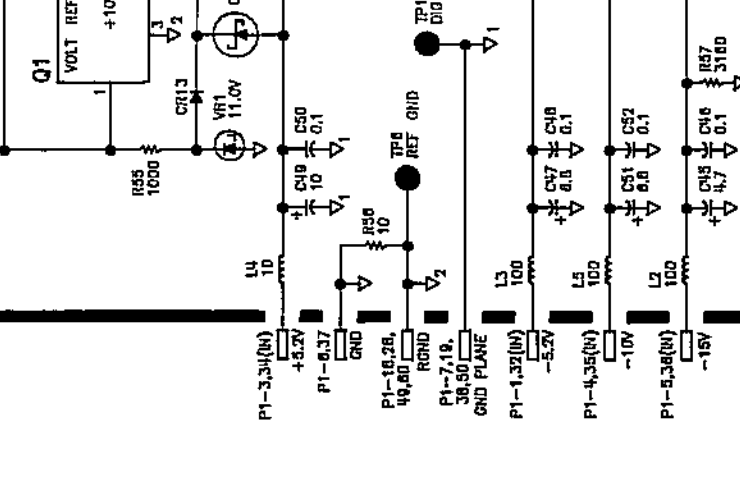

ADC CLOCK/CONTROL

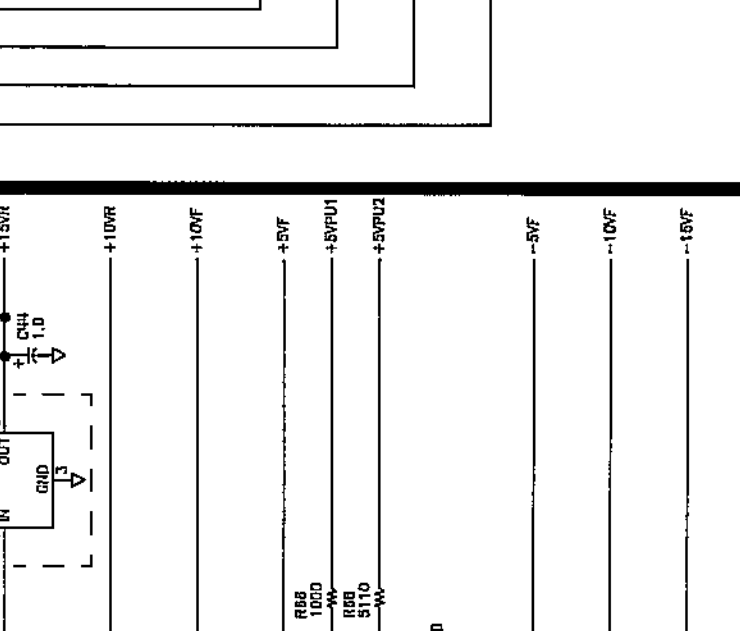

ADC

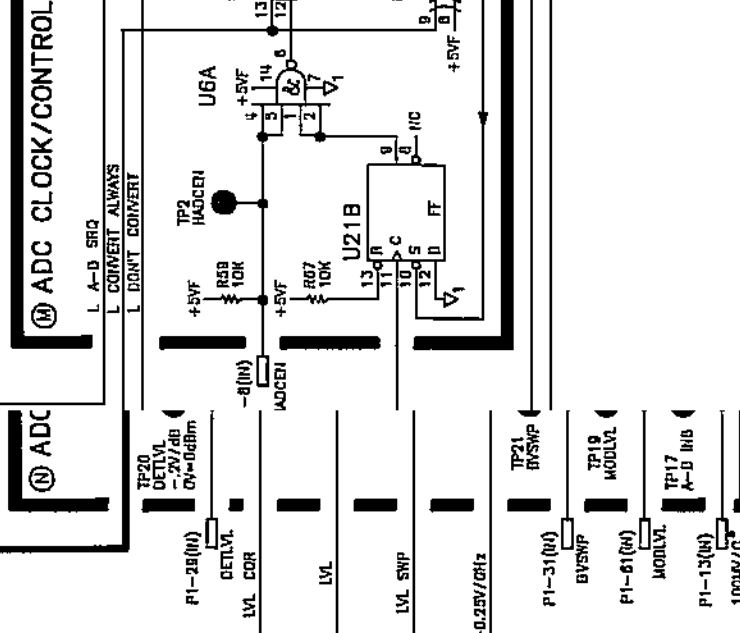

CONVERSION COMPLETE TIMER/SRQ LATCH

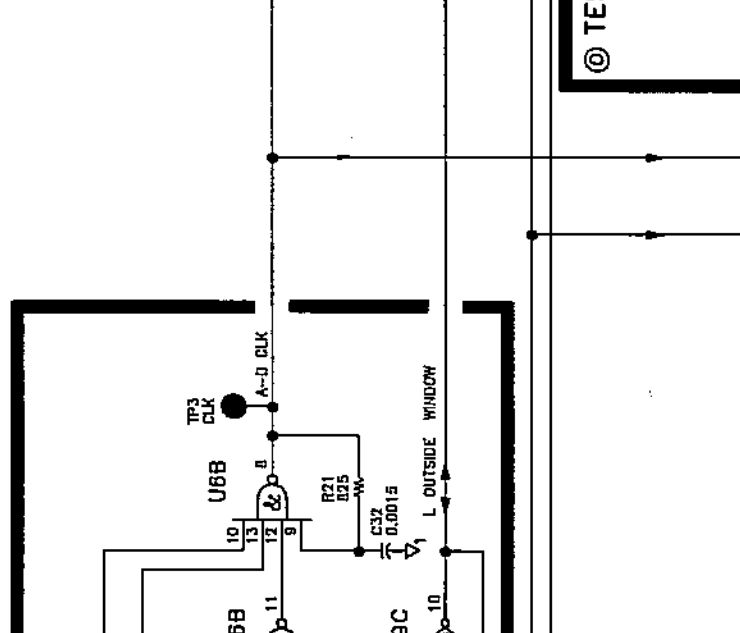

TEST ADC

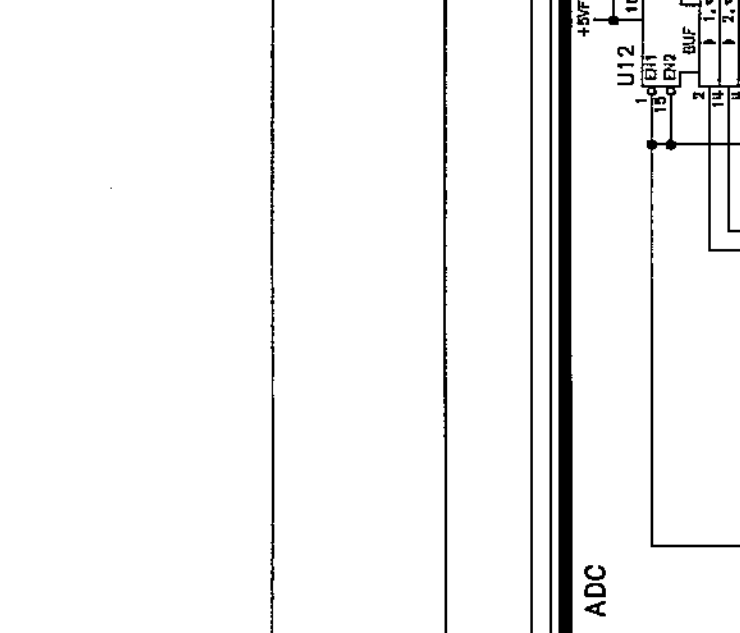

INPUT MULTIPLEXER

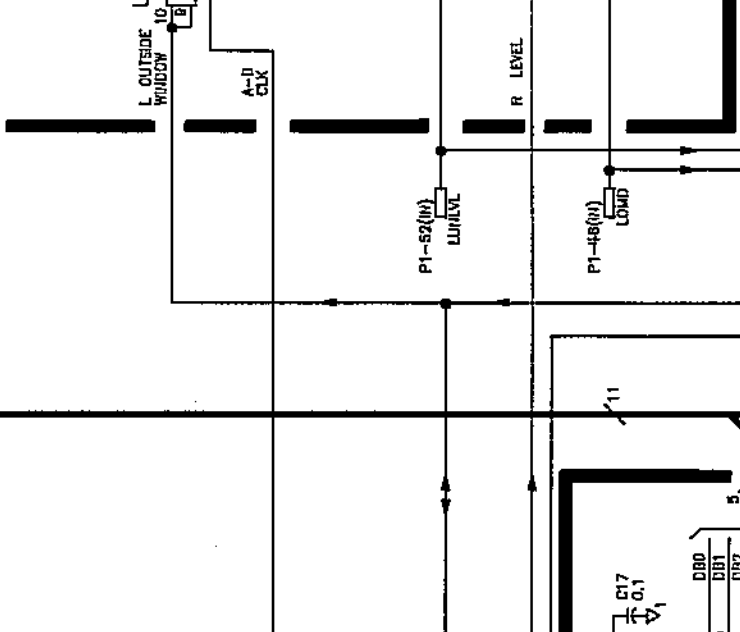

ADC WINDOW COMPARATOR

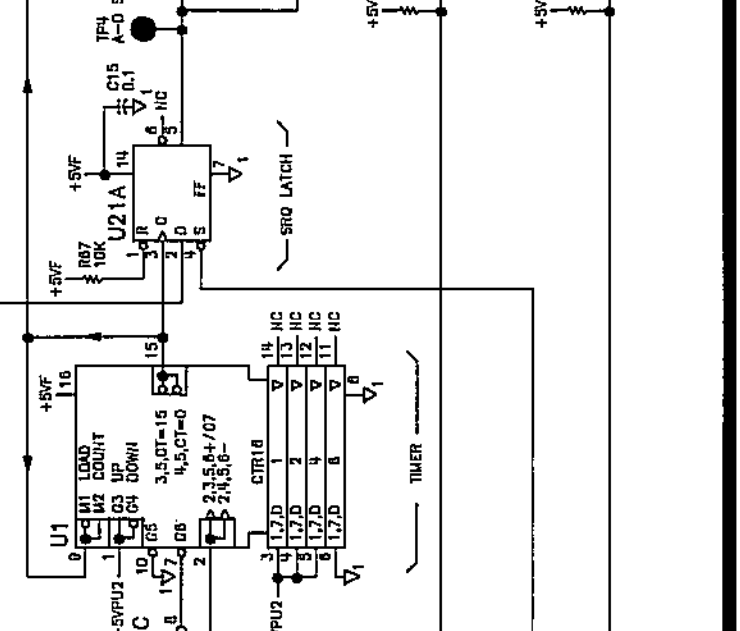

STATUS BUFFER

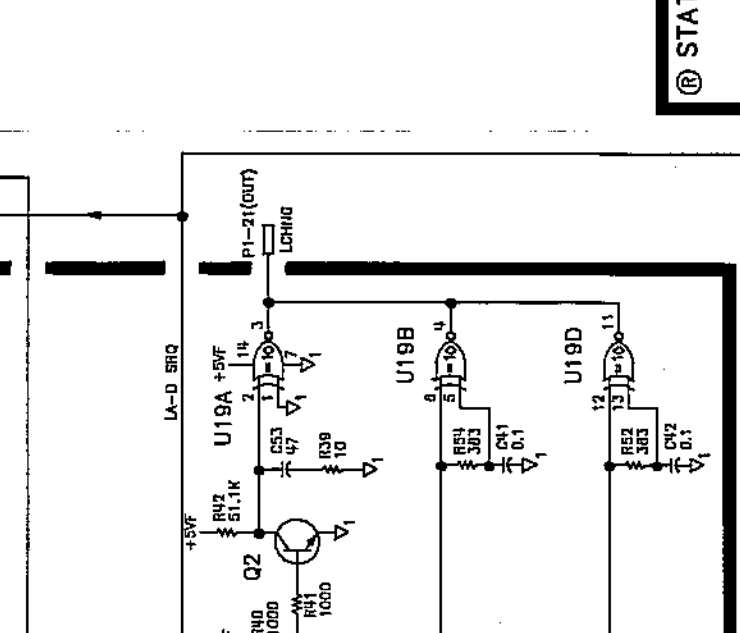

NOTES:

1. RESISTANCE VALUES ARE IN OHMS UNLESS OTHERWISE SPECIFIED. CAPACITANCE VALUES ARE IN MICROFARADS UNLESS OTHERWISE SPECIFIED.
2. FOR OPTION 004 OR 005 (REAR PANEL OUTPUT) DELETE R71 AND REPLACE R70 WITH A JUMPER.

A27 LEVEL CONTROL
08340-60237 (SHEET 2 OF 2)

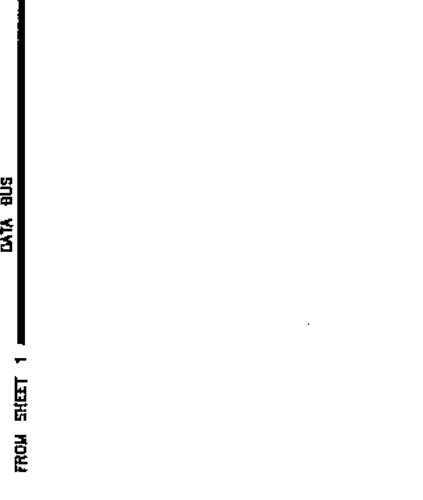

A27 Level Control Component-Level Troubleshooting

Table A27-2. A27 Level Control Replaceable Parts

Reference Designation	HP Part Number	C D	Qty	Description	Mfr Code	Mfr Part Number
A27	08340-60237	4	1	LEVEL CONTROL ASSEMBLY	28480	08340-60237
A27C1	0160-4084	8	16	CAPACITOR-FXD 1UF ±20% 50VDC CER	28480	0160-4084
A27C2	0160-4084	8		CAPACITOR-FXD 1UF ±20% 50VDC CER	28480	0160-4084
A27C3	0160-3878	6	3	CAPACITOR-FXD 1000PF ±20% 100VDC CER	28480	0160-3878
A27C4	0160-3876	4	3	CAPACITOR-FXD 47PF ±20% 200VDC CER	28480	0160-3876
A27C5	0160-3879	7	18	CAPACITOR-FXD 01UF ±20% 100VDC CER	28480	0160-3879
A27C6	0160-3879	7		CAPACITOR-FXD 01UF ±20% 100VDC CER	28480	0160-3879
A27C7	0160-3879	7		CAPACITOR-FXD 01UF ±20% 100VDC CER	28480	0160-3879
A27C8	0160-3879	7		CAPACITOR-FXD 01UF ±20% 100VDC CER	28480	0160-3879
A27C9	0160-3878	6		CAPACITOR-FXD 1000PF ±20% 100VDC CER	28480	0160-3878
A27C10	0160-3876	4		CAPACITOR-FXD 47PF ±20% 200VDC CER	28480	0160-3876
A27C11	0160-4084	8		CAPACITOR-FXD 1UF ±20% 50VDC CER	28480	0160-4084
A27C12	0160-4084	8		CAPACITOR-FXD 1UF ±20% 50VDC CER	28480	0160-4084
A27C13	0160-3878	6		CAPACITOR-FXD 1000PF ±20% 100VDC CER	28480	0160-3878
A27C14	0160-3876	4		CAPACITOR-FXD 47PF ±20% 200VDC CER	28480	0160-3876
A27C15	0160-3879	7		CAPACITOR-FXD 01UF ±20% 100VDC CER	28480	0160-3879
A27C16	0160-3879	7		CAPACITOR-FXD 01UF ±20% 100VDC CER	28480	0160-3879
A27C17	0160-4084	8		CAPACITOR-FXD 1UF ±20% 50VDC CER	28480	0160-4084
A27C18	0160-4084	8		CAPACITOR-FXD 1UF ±20% 50VDC CER	28480	0160-4084
A27C19	0160-3879	7		CAPACITOR-FXD 01UF ±20% 100VDC CER	28480	0160-3879
A27C20	0160-4084	8		CAPACITOR-FXD 1UF ±20% 50VDC CER	28480	0160-4084
A27C21	0160-3879	7		CAPACITOR-FXD 01UF ±20% 100VDC CER	28480	0160-3879
A27C22				NOT ASSIGNED		
A27C23	0160-3879	7		CAPACITOR-FXD 01UF ±20% 100VDC CER	28480	0160-3879
A27C24	0160-3879	7		CAPACITOR-FXD 01UF ±20% 100VDC CER	28480	0160-3879
A27C25				NOT ASSIGNED		
A27C26	0160-3879	7		CAPACITOR-FXD 01UF ±20% 100VDC CER	28480	0160-3879
A27C27	0160-3879	7		CAPACITOR-FXD 01UF ±20% 100VDC CER	28480	0160-3879
A27C28	0160-3879	7		CAPACITOR-FXD 01UF ±20% 100VDC CER	28480	0160-3879
A27C29				NOT ASSIGNED		
A27C30	0160-3879	7		CAPACITOR-FXD 01UF ±20% 100VDC CER	28480	0160-3879
A27C31	0180-2661	5	2	CAPACITOR-FXD 1UF ±10% 50VDC TA	25088	D1R0GS1A50K
A27C32	0160-4846	0	1	CAPACITOR-FXD 1500PF ±5% 100VDC CER	28480	0160-4846
A27C33	0160-3879	7		CAPACITOR-FXD 01UF ±20% 100VDC CER	28480	0160-3879
A27C34	0160-3879	7		CAPACITOR-FXD 01UF ±20% 100VDC CER	28480	0160-3879
A27C35	0160-3879	7		CAPACITOR-FXD 01UF ±20% 100VDC CER	28480	0160-3879
A27C36				NOT ASSIGNED		
A27C37	0160-3879	7		CAPACITOR-FXD 01UF ±20% 100VDC CER	28480	0160-3879
A27C38	0160-4084	8		CAPACITOR-FXD 1UF ±20% 50VDC CER	28480	0160-4084
A27C39	0160-4084	8		CAPACITOR-FXD 1UF ±20% 50VDC CER	28480	0160-4084
A27C40	0160-4084	8		CAPACITOR-FXD 1UF ±20% 50VDC CER	28480	0160-4084
A27C41	0160-4084	8		CAPACITOR-FXD 1UF ±20% 50VDC CER	28480	0160-4084
A27C42	0160-4084	8		CAPACITOR-FXD 1UF ±20% 50VDC CER	28480	0160-4084
A27C43	0180-0630	4	2	CAPACITOR-FXD 4 7UF ±20% 50VDC TA	28480	0180-0630
A27C44	0180-2661	5		CAPACITOR-FXD 1UF ±10% 50VDC TA	25088	D1R0GS1A50K
A27C45	0180-0630	4		CAPACITOR-FXD 4 7UF ±20% 50VDC TA	28480	0180-0630
A27C46	0160-4084	8		CAPACITOR-FXD 1UF ±20% 50VDC CER	28480	0160-4084
A27C47	0180-2617	1	2	CAPACITOR-FXD 6 8UF ±10% 35VDC TA	25088	D6R8GS1B35K
A27C48	0160-4084	8		CAPACITOR-FXD 1UF ±20% 50VDC CER	28480	0160-4084
A27C49	0180-2697	7	1	CAPACITOR-FXD 10UF ±10% 25VDC TA	28480	0180-2697
A27C50	0160-4084	8		CAPACITOR-FXD 1UF ±20% 50VDC CER	28480	0160-4084
A27C51	0180-2617	1		CAPACITOR-FXD 6 8UF ±10% 35VDC TA	25088	D6R8GS1B35K
A27C52	0160-4084	8		CAPACITOR-FXD 1UF ±20% 50VDC CER	28480	0160-4084
A27C53	0180-0500	7	1	CAPACITOR-FXD 47UF ±20% 20VDC TA	28480	0180-0500
A27C54	0160-3875	3	2	CAPACITOR-FXD 22PF ±5% 200VDC CER 0±30	28480	0160-3875
A27C55	0160-3875	3		CAPACITOR-FXD 22PF ±5% 200VDC CER 0±30	28480	0160-3875
A27CR1	1901-0050	3	8	DIODE-SWITCHING 80V 200MA 2NS DO-35	28480	1901-0050
A27CR2	1901-0050	3		DIODE-SWITCHING 80V 200MA 2NS DO-35	28480	1901-0050
A27CR3	1901-0050	3		DIODE-SWITCHING 80V 200MA 2NS DO-35	28480	1901-0050
A27CR4	1901-0050	3		DIODE-SWITCHING 80V 200MA 2NS DO-35	28480	1901-0050
A27CR5	1901-0050	3		DIODE-SWITCHING 80V 200MA 2NS DO-35	28480	1901-0050
A27CR6	1901-0050	3		DIODE-SWITCHING 80V 200MA 2NS DO-35	28480	1901-0050
A27CR7	1901-0050	3		DIODE-SWITCHING 80V 200MA 2NS DO-35	28480	1901-0050
A27CR8	1901-0518	8	5	DIODE-SM SIG SCHOTTKY	28480	1901-0518
A27CR9	1901-0518	8		DIODE-SM SIG SCHOTTKY	28480	1901-0518
A27CR10	1901-0518	8		DIODE-SM SIG SCHOTTKY	28480	1901-0518
A27CR11	1901-0518	8		DIODE-SM SIG SCHOTTKY	28480	1901-0518
A27CR12	1901-0518	8		DIODE-SM SIG SCHOTTKY	28480	1901-0518
A27CR13	1901-0050	3		DIODE-SWITCHING 80V 200MA 2NS DO-35	28480	1901-0050
A27DS1	1990-0486	6	1	LED-LAMP LUM-INT=1MCD IF=20MA-MAX VBR=5V	28480	5082-4684

A27 Level Control Component-Level Troubleshooting

Table A27-2. A27 Level Control Replaceable Parts

Reference Designation	HP Part Number	C D	Qty	Description	Mfr Code	Mfr Part Number
A27L1	9140-0210	1	4	INDUCTOR RF-CH-MLD 100UH 5% 166DX 385LG	28480	9140-0210
A27L2	9140-0210	1		INDUCTOR RF-CH-MLD 100UH 5% 166DX 385LG	28480	9140-0210
A27L3	9140-0210	1		INDUCTOR RF-CH-MLD 100UH 5% 166DX 385LG	28480	9140-0210
A27L4	9140-0114	4	1	INDUCTOR RF-CH-MLD 10UH 10% 166DX 385LG	28480	9140-0114
A27L5	9140-0210	1		INDUCTOR RF-CH-MLD 100UH 5% 166DX 385LG	28480	9140-0210
A27MP1	1200-0173	5	2	INSULATOR-XSTR DAP-GL	28480	1200-0173
A27MP2	1205-0011	0	1	HEAT SINK TO-5/TO-39-CS	28480	1205-0011
A27MP3	4040-0750	7	1	EXTR-PC BD RED POLYCO 062-BD-THKNS	28480	4040-0750
A27MP4, 5	1480-0073	6	2	PIN-ROLL 062-IN-DIA 25-IN-LG BE-CU	28480	1480-0073
A27MP6	4040-0755	2	1	EXTR-PC BD VIO POLYCO 062-BD-THKNS	28480	4040-0755
A27Q1	1826-0730	6	1	IC V RGLTR-V-REF-FXD 10V TO-5 PKG	28480	1826-0730
A27Q2	1854-0477	7	1	TRANSISTOR NPN 2N2222A SITO-18 PD=500MW	04713	2N2222A
A27Q3	1826-0512	2	1	IC 78M15C V RGLTR TO-39	04713	MC78M15CG
A27R1	0698-6360	6	7	RESISTOR 10K 1% 125W F TC=0±25	28480	0698-6360
A27R2	0698-6360	6	2	RESISTOR 10K 1% 125W F TC=0±25	28480	0698-6360
A27R3	0698-6977	1	1	RESISTOR 30K 1% 125W F TC=0±25 (RECOMMENDED REPLACEMENT)	28480	0698-6977
A27R4	2100-3353	8	1	RESISTOR-TRMR 20K 10% C SIDE-ADJ 1-TRN (RECOMMENDED REPLACEMENT)	28480	2100-3353
A27R5	0698-6360	6		RESISTOR 10K 1% 125W F TC=0±25	28480	0698-6360
A27R6	0698-6360	6		RESISTOR 10K 1% 125W F TC=0±25	28480	0698-6360
A27R7	0698-3136	8	1	RESISTOR 17.8K 1% 125W F TC=0±100	24546	C4-1/8-T0-1782-F
A27R8	2100-3207	1	1	RESISTOR-TRMR 5K 10% C SIDE-ADJ 1-TRN	28480	2100-3207
A27R9	0698-6630	3	1	RESISTOR 20K 1% 125W F TC=0±25	28480	0698-6630
A27R10	0698-6320	8	2	RESISTOR 5K 1% 125W F TC=0±25	03888	PME55-1/8-T9-5001-B
A27R11	0698-6347	9	1	RESISTOR 1.5K 1% 125W F TC=0±25	28480	0698-6347
A27R12	0698-6631	4	2	RESISTOR 2.5K 1% 125W F TC=0±25	28480	0698-6631
A27R13	0698-6624	5		RESISTOR 2K 1% 125W F TC=0±25	28480	0698-6624
A27R14				NOT ASSIGNED		
A27R15	0757-0442	9	6	RESISTOR 10K 1% 125W F TC=0±100	24546	C4-1/8-T0-1002-F
A27R16	0698-6360	6		RESISTOR 10K 1% 125W F TC=0±25	28480	0698-6360
A27R17	0698-6360	6		RESISTOR 10K 1% 125W F TC=0±25	28480	0698-6360
A27R18	0698-6320	8		RESISTOR 5K 1% 125W F TC=0±25	03888	PME55-1/8-T9-5001-B
A27R19	0698-6362	8	1	RESISTOR 1K 1% 125W F TC=0±25	28480	0698-6362
A27R20	0757-0418	9	1	RESISTOR 619 1% 125W F TC=0±100	24546	C4-1/8-T0-619R-F
A27R21	0757-0421	4	1	RESISTOR 825 1% 125W F TC=0±100	24546	C4-1/8-T0-825R-F
A27R22	0698-3446	3	3	RESISTOR 383 1% 125W F TC=0±100	24546	C4-1/8-T0-383R-F
A27R23	0699-0118	2	1	RESISTOR-20K OHM 1% 1W	28480	0699-0118
A27R24	0699-0144	4	2	RESISTOR-10K OHM 1% 1W	28480	0699-0144
A27R25	0699-0144	4		RESISTOR-10K OHM 1% 1W	28480	0699-0144
A27R26	0698-6360	6		RESISTOR 10K 1% 125W F TC=0±25	28480	0698-6360
A27R27				NOT ASSIGNED		
A27R28	0698-6353	7	8	RESISTOR 50K 1% 125W F TC=0±25	28480	0698-6353
A27R29	0698-6353	7		RESISTOR 50K 1% 125W F TC=0±25	28480	0698-6353
A27R30	0698-6353	7		RESISTOR 50K 1% 125W F TC=0±25	28480	0698-6353
A27R31	0698-6353	7		RESISTOR 50K 1% 125W F TC=0±25	28480	0698-6353
A27R32	0698-8191	5	1	RESISTOR 12.5K 1% 125W F TC=0±25	15701	MF4C1/8-T9-1252-B
A27R33	0698-6353	7		RESISTOR 50K 1% 125W F TC=0±25	28480	0698-6353
A27R34	0698-6977	1	1	RESISTOR 30K 1% 125W F TC=0±25	28480	0698-6977
A27R35	0698-6353	7		RESISTOR 50K 1% 125W F TC=0±25	28480	0698-6353
A27R36	0698-6353	7		RESISTOR 50K 1% 125W F TC=0±25	28480	0698-6353
A27R37				NOT ASSIGNED		
A27R38	0698-6353	7		RESISTOR 50K 1% 125W F TC=0±25	28480	0698-6353
A27R39	0757-0346	2	2	RESISTOR 10 1% 125W F TC=0±100	24546	C4-1/8-T0-10R0-F
A27R40	0757-0280	3	5	RESISTOR 1K 1% 125W F TC=0±100	24546	C4-1/8-T0-1001-F
A27R41	0757-0280	3		RESISTOR 1K 1% 125W F TC=0±100	24546	C4-1/8-T0-1001-F
A27R42	0757-0458	7	1	RESISTOR 51.1K 1% 125W F TC=0±100	24546	C4-1/8-T0-5112-F
A27R43	0698-6631	4		RESISTOR 2.5K 1% 125W F TC=0±25	28480	0698-6631
A27R44	0757-0465	6	1	RESISTOR 100K 1% 125W F TC=0±100	24546	C4-1/8-T0-1003-F
A27R45	0757-0438	3	2	RESISTOR 5.11K 1% 125W F TC=0±100	24546	C4-1/8-T0-5111-F
A27R46	0757-0280	3		RESISTOR 1K 1% 125W F TC=0±100	24546	C4-1/8-T0-1001-F
A27R47	0757-0442	9		RESISTOR 10K 1% 125W F TC=0±100	24546	C4-1/8-T0-1002-F
A27R48	0757-0398	4	2	RESISTOR 75 1% 125W F TC=0±100	24546	C4-1/8-T0-75R0-F
A27R49	0757-0442	9		RESISTOR 10K 1% 125W F TC=0±100	24546	C4-1/8-T0-1002-F
A27R50	0757-0442	9		RESISTOR 10K 1% 125W F TC=0±100	24546	C4-1/8-T0-1002-F
A27R51	0757-0422	5	2	RESISTOR 909 1% 125W F TC=0±100	24546	C4-1/8-T0-909R-F
A27R52	0698-3446	3		RESISTOR 383 1% 125W F TC=0±100	24546	C4-1/8-T0-383R-F
A27R53	0757-0422	5		RESISTOR 909 1% 125W F TC=0±100	24546	C4-1/8-T0-909R-F
A27R54	0698-3446	3		RESISTOR 383 1% 125W F TC=0±100	24546	C4-1/8-T0-383R-F
A27R55	0757-0280	3		RESISTOR 1K 1% 125W F TC=0±100	24546	C4-1/8-T0-1001-F

A27 Level Control Component-Level Troubleshooting

Table A27-2. A27 Level Control Replaceable Parts

Reference Designation	HP Part Number	C D	Qty	Description	Mfr Code	Mfr Part Number
A27R56	0757-0346	2		RESISTOR 10 1% 125W F TC=0±100	24546	C4-1/8-T0-10R0-F
A27R57	0757-0279	0	1	RESISTOR 3 16k 1% 125W F TC=0±100	24546	C4-1/8-T0-3161-F
A27R58	0757-0444	1	1	RESISTOR 12 1k 1% 125W F TC=0±100	24546	C4-1/8-T0-1212-F
A27R59	0757-0442	9		RESISTOR 10k 1% 125W F TC=0±100	24546	C4-1/8-T0-1002-F
A27R60	0757-0398	4		RESISTOR 75 1% 125W F TC=0±100	24546	C4-1/8-T0-75R0-F
A27R61	0698-6358	2	4	RESISTOR 100k 1% 125W F TC=0±25	28480	0698-6358
A27R62	0698-6358	2		RESISTOR 100k 1% 125W F TC=0±25	28480	0698-6358
A27R63	0698-6358	2		RESISTOR 100k 1% 125W F TC=0±25	28480	0698-6358
A27R64	0698-6358	2		RESISTOR 100k 1% 125W F TC=0±25	28480	0698-6358
A27R65	0811-3575	1	1	RESISTOR-3K OHM 2% 12W	28480	0811-3575
A27R66	0757-0280	3		RESISTOR 1k 1% 125W F TC=0±100	24546	C4-1/8-T0-1001-F
A27R67	0757-0442	9		RESISTOR 10k 1% 125W F TC=0±100	24546	C4-1/8-T0-1002-F
A27R68	0757-0438	3		RESISTOR 5 11k 1% 125W F TC=0±100	24546	C4-1/8-T0-5111-F
A27R69	0698-8824	1	1	RESISTOR 562k 1% 125W F TC=0±100	28480	0698-8824
A27R70	0698-3150	6	1	RESISTOR 2 37k 1% 125W F TC=0±100 STANDARD INSTRUMENT	24546	C4-1/8-T0-2371-F
				OPTION 004 AND 005 R P RF OUT REPLACE A27R70 WITH A SHORT CIRCUIT		
A27R71	0698-0085	0	1	RESISTOR 2 61k 1% 125W F TC=0±100 STANDARD INSTRUMENT	24546	C4-1/8-T0-2611-F
				OPTION 004 AND 005 INSTRUMENTS DELETE A27R71		
A27RT1	0837-0105	1	1	THERMISTOR BEAD 200K-OHM TC=-4.9%/C-DEG	28480	0837-0105
A27TP1-21	0360-0535	0	21	TERMINAL TEST POINT PCB	00000	ORDER BY DESCRIPTION
A27U1	1820-1435	8	1	IC CNTR TTL LS BIN UP/DOWN SYNCHRO	01295	SN74LS669N
A27U2	1826-0026	3	2	IC COMPARATOR PRCN TO-99 PKG	01295	LM311L
A27U3	1826-0026	3		IC COMPARATOR PRCN TO-99 PKG	01295	LM311L
A27U4	1826-0092	3	3	IC OP AMP GP DUAL TO-99 PKG	28480	1826-0092
A27U5	1826-0092	3		IC OP AMP GP DUAL TO-99 PKG	28480	1826-0092
A27U6	1820-1415	4	1	IC SCHMITT-TRIG TTL LS NAND DUAL 4-INP	01295	SN74LS13N
A27U7	1826-0471	2	3	IC OP AMP LOW-DRIFT TO-99 PKG	28480	1826-0471
A27U8	1826-0798	6	3	IC-5018 C1 DAC	18324	NE5018F
A27U9	1826-0798	6		IC-5018 C1 DAC	18324	NE5018F
A27U10	1826-0798	6		IC-5018 C1 DAC	18324	NE5018F
A27U11	1826-0881	8	1	IC-8560 C1 ADC	28480	1826-0881
A27U12	1820-1491	6	3	IC BFR TTL LS NON-INV HEX 1-INP	01295	SN74LS367AN
A27U13	1820-1196	8	5	IC FF TTL LS D-TYPE POS-EDGE-TRIG COM	01295	SN74LS174N
A27U14	1826-0921	7	2	D/A 10-BIT 16 CBRZ/SDR CMOS (RECOMMENDED REPLACEMENT)	07050	MP7533MP
A27U15	1820-1491	6		IC BFR TTL LS NON-INV HEX 1-INP	01295	SN74LS367AN
A27U16	1820-1196	8		IC FF TTL LS D-TYPE POS-EDGE-TRIG COM	01295	SN74LS174N
A27U17	1826-0471	2		IC OP AMP LOW-DRIFT TO-99 PKG	28480	1826-0471
A27U18	1826-0092	3		IC OP AMP GP DUAL TO-99 PKG	28480	1826-0092
A27U19	1820-1297	0	1	IC GATE TTL LS EXCL-NOR QUAD 2-INP	01295	SN74LS266N
A27U20	1820-1216	3	2	IC DCDR TTL LS 3-TO-8-LINE 3-INP	01295	SN74LS138N
A27U21	1820-1112	8	1	IC FF TTL LS D-TYPE POS-EDGE-TRIG	01295	SN74LS74AN
A27U22	1820-1491	6		IC BFR TTL LS NON-INV HEX 1-INP	01295	SN74LS367AN
A27U23	1820-1196	8		IC FF TTL LS D-TYPE POS-EDGE-TRIG COM	01295	SN74LS174N
A27U24	1826-0921	7		D/A 10-BIT 16 CBRZ/SDR CMOS (RECOMMENDED REPLACEMENT)	07050	MP7533MP
A27U25	1826-0609	8	1	IC MULTIPLEXR ANLG 16-DIP-C PKG	06665	MUX08FQ
A27U26	1820-1197	9	1	IC GATE TTL LS NAND QUAD 2-INP	01295	SN74LS00N
A27U27	1820-1216	3		IC DCDR TTL LS 3-TO-8-LINE 3-INP	01295	SN74LS138N
A27U28	1820-1195	7	1	IC FF TTL LS D-TYPE POS-EDGE-TRIG COM	01295	SN74LS175N
A27U29	1820-1196	8		IC FF TTL LS D-TYPE POS-EDGE-TRIG COM	01295	SN74LS174N
A27U30	1820-1196	8		IC FF TTL LS D-TYPE POS-EDGE-TRIG COM	01295	SN74LS174N
A27U31	1826-0471	2		IC OP AMP LOW-DRIFT TO-99 PKG	28480	1826-0471
A27U32	1810-0318	3	4	RESISTIVE NETWORK-6 PINS	01121	206A102
A27U33	1810-0318	3		RESISTIVE NETWORK-6 PINS	01121	206A102
A27U34	1810-0318	3		RESISTIVE NETWORK-6 PINS	01121	206A102
A27U35	1810-0318	3		RESISTIVE NETWORK-6 PINS	01121	206A102
A27VR1	1902-3171	7	1	DIODE-ZNR 11V 5% DO-35 PD= 4W TC=+ 062%	28480	1902-3171

A28 SYTM Driver Circuit Description

ASSEMBLY PURPOSE

The SYTM driver provides the magnet drive current to the SYTM coil to tune the SYTM frequency under all conditions. Because the SYTM uses an open-loop tracking scheme, all differences in tracking conditions must be compensated for by this assembly without the benefit of feedback. The A28 SYTM driver also provides the rest of the instrument with voltages proportional to frequency (-0.25 V/GHz , $1.0/0.5\text{ V/GHz}$, and 1.4 V/GHz).

OFFSET COMPENSATION (BLOCK A)

The offset compensation circuitry adds a correction current at the beginning of the magnet drive current ramp, independent of frequency. The offset, digitally input by the instrument microprocessor, affects the entire operating range of the SYTM and has a range of $\pm 200\text{ MHz}$. The offset compensation output is summed in the compensation summing amplifier (see Figure A28-1).

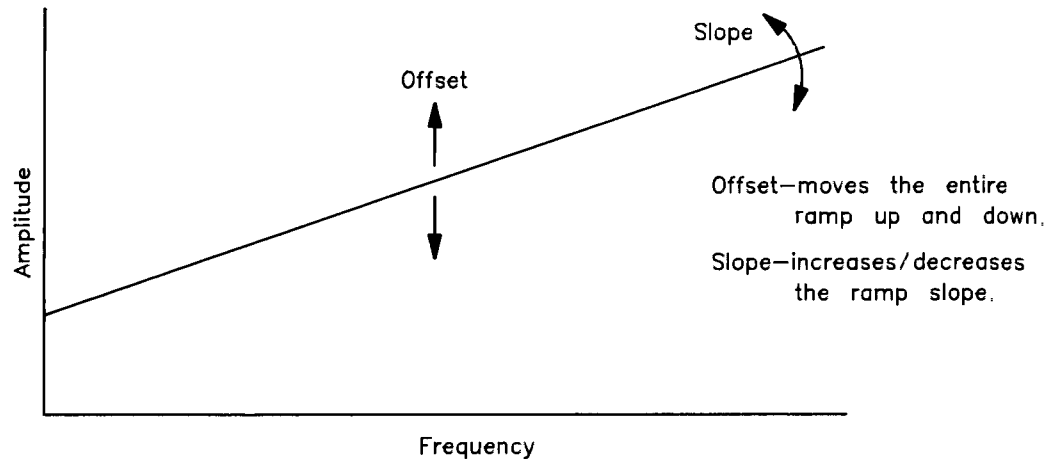

Figure A28-1. Magnet Drive Offset and Slope Compensation

DELAY COMPENSATION (BLOCK B)

The SYTM magnet eddy currents oppose any change in coil current. During a sweep, while the input current is ramping, the eddy currents set up a magnetic field that partially cancels the magnetic field required to tune the SYTM passband. To offset this, a compensation current is added to the current driving the SYTM.

The start of the compensation ramp goes through a buffer, is rounded by an integrator, and scaled by the scaling DAC. The slope of the rest of the ramp is set by the output DAC (see Figure A28-2).

The scaling DAC and the output DAC give the instrument microprocessor control over the gain of the delay correction. The faster the sweep speed, the greater the compensation

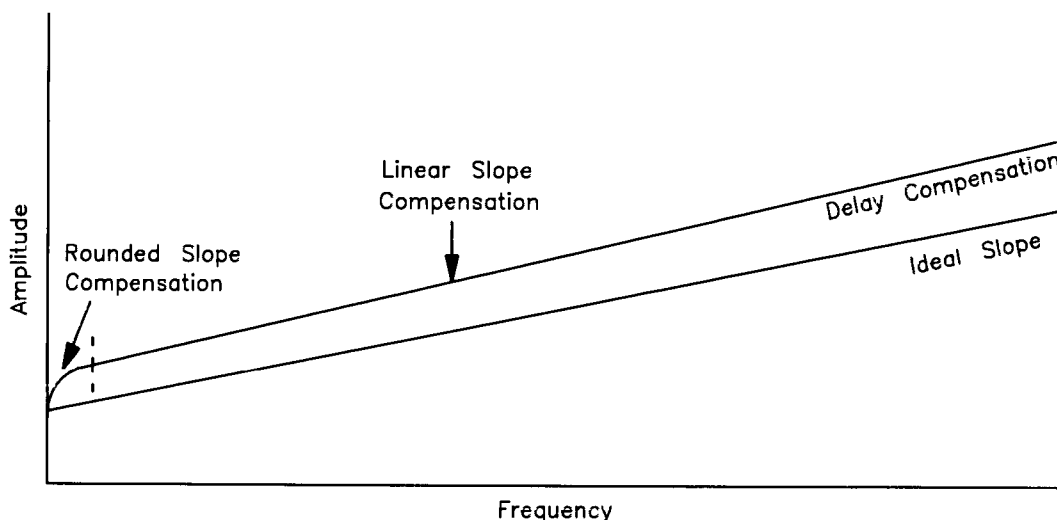

Figure A28-2. Magnet Drive Delay Compensation

SLOPE COMPENSATION (BLOCK C)

The slope compensation circuitry adds a correction current proportional to frequency that varies the slope of the SYTM magnet drive current ramp (see Figure A28-1).

In addition to the correction provided by the slope DAC, three breakpoints correct for the non-linearities of the SYTM magnet.

COMPENSATION SUMMING AMPLIFIER (BLOCK D)

The currents generated by the slope, offset, and delay compensation circuitry are amplified in the summing amplifier. An output transistor buffers the operational amplifier output, allowing the amplifier to have a higher output voltage capability. The compensation summing amplifier pulls the passband of the SYTM over the range of -220 MHz to $+625$ MHz. An output offset adjustment allows setting the compensation level to the SYTM.

VOLTAGE REFERENCE (BLOCK E)

The +20V supply provides the input to the +10 VREF and +15 VF output regulators. An inverting amplifier generates the -10 VREF supply for use on the SYTM driver assembly.

POWER SUPPLIES (BLOCK F)

The power supplies coming to the assembly are:

- +20V
- +5.2V
- -10V
- -15V
- -40V

All supplies (except -40V) are low-pass filtered.

PROGRAMMABLE SCALAR (BLOCK G)

The pretune line, a voltage proportional to YO frequency, comes to the SYTM driver board. It is adjusted to give -2.5 V/GHz, with an accuracy of $\pm 6.5\text{mV}$.

The programmable voltage divider uses a precision resistor array to attenuate the PRETUNE voltage, giving a voltage proportional to SYTM frequency. The overall accuracy depends on the accuracy of the PRETUNE line, as well as that of the resistor array.

The latched band information from the digital control circuitry (block I) is the input for an analog switch. The outputs of the switch are input to the -0.25 V/GHz circuitry, and the SYTM current driver.

-0.25V/GHz (BLOCK H)

The -0.25 V/GHz line is the most widely used signal on the SYTM driver assembly. During high band operation, it is a buffered version of the voltage out of the programmable scalar. The input amplifier has a low offset voltage (maximum 1.6 mV, 0 to 70°C) and keeps the output within 1.6 mV of the input signal. During low band operation, the instrument frequency is equal to the YO frequency offset by 3.7 GHz. The -0.25 V/GHz line uses the PRETUNE voltage, scales it down to -0.25 V/GHz and adds an offset voltage that equals $(0.25 \text{ V/GHz}) \times (3.7 \text{ GHz})$, or 0.925V. This signal is generated using the +10V reference, offset adjustment V/GHz, and PRETUNE.

Analog switches select between the low band and high band conditions. A sample and hold circuit removes the discontinuities present due to changing the band number and PRETUNE at different times.

DIGITAL CONTROL (BLOCK I)

The following digital control signals are used on the SYTM driver assembly:

Input Digital Control Lines

- L YO KICK. Gating control signal for the HTRACK and HENDKICK output signals.
- L WSYTMCTL. Enable control line for the input data latch that provides instrument processor control of several output control lines.
- L WSYTMSLP and L WBAND. Input control lines from the instrument processor for compensation control outputs.
- HLB0, HLB1, and HLB2. Control signals providing latched band information that is decoded to generate low and high band control lines

Output Digital Control Lines

- H TRACK. Output control for analog switches in the -0.25 V/GHz circuitry (block H) to remove band change discontinuities.
- H ENDKICK. High output when the SYTM and YO kick pulses are off. Routed to the A24 assembly to be read by the instrument processor. If the signal remains low for more than 90 ms, a kick error is indicated.
- L KICK TRIGGER. When set high momentarily, initiates the SYTM kick pulse (block L). L KICK TRIGGER is an active low signal, approximately 20 μ s wide.
- L WR SLOPE COMP, L WR OFFSET COMP, LWR DELAY COMP, and LWR RISE COMP. DAC enable control lines to latch the instrument processor inputs into the offset, delay, and slope compensation circuitry.

+1.0/ +0.5 V/GHz (BLOCK J)

This block provides a voltage proportional to the instrument frequency. The standard instrument sensitivity is +0.5 V/GHz. You can configure the instrument to a sensitivity of +1.0 V/GHz by adding two jumpers (W1 and W2) on the SYTM driver assembly. In this configuration, the output is limited to approximately +19V (+20V supply tolerance and 0.4V saturation across the output transistor)

A current source with an output of approximately 1.2 mA, gives an offset of approximately +5V. An output capacitor ensures that the 0 dB gain crossover for the loop has a slope of -6 dB/octave. Protection diodes protect the circuitry from voltages that may inadvertently be applied to the output.

CURRENT DRIVER (BLOCK K)

The current driver input node sensitivity is 4 MHz/mV. The impedance of the line can be as much as 2.6K ohms. To keep leakage current errors less than 1 MHz, the leakage currents must be kept below 100 nA. To do this, guard traces driven by a buffered version of the same voltage are placed around the sensitive traces.

Because of the inductance of the SYTM coil, a voltage spike is generated when the current ramp resets. The zener diode prevents this voltage kick from exceeding the breakdown voltage for the transistors by controlling the maximum allowed rate of change of current from the driver. An emitter diode protects the base-emitter junction of the output transistor from large voltages that could cause a breakdown. A bypass capacitor provides low capacitance in series with the output zener diode to reduce the effect of the zener diode's junction capacitance.

The zener diode protection circuit clamps the inductive voltage at approximately 140V. This circuit protects the drive transistor (on the A47 assembly) in case the SYTM driver assembly is pulled out while the instrument is on. The breakdown voltage of the drive transistor is 400V.

During a bandswitch, the -0.25 V/GHz voltage is more accurate for holding the SYTM at the desired current than is the normal attenuated PRETUNE voltage. At these times, the -0.25 V/GHz line is gated to override the attenuated PRETUNE voltage to hold the SYTM and avoid the undesired kick pulses due to discontinuities on the attenuated PRETUNE line. When the instrument is in low band, the SYTM magnet is tuned to about 4 GHz to keep the YIG sphere from interfering with the output.

KICK PULSE (BLOCK L)

The SYTM is kicked positive in frequency until a predetermined current is reached, then the SYTM is kicked negative in frequency until a second predetermined current is reached. The SYTM settles from that point. The kick pulses minimize the differences between the various sweep conditions (continuous, line, external, single, and alternate). They are not needed at bandcrossings because the SYTM's past history at bandcrossings is similar to that provided by the kick pulses.

A28 SYTM Driver Component-Level Troubleshooting

Table A28-1. A28 SYTM Driver P1 Pin I/O

Pin	Mnemonic	Levels	Source	Destination
1 23	+20V +20V	+20V +20V	XA52P1-16, 40 XA52P1-16, 40	*L *L
2 24	+5.2V +5.2V	+5.2V +5.2V	XA52P1-17, 18, 41, 42 XA52P1-17, 18, 41, 42	*L *L
3 25	-10V -10V	-10V -10V	XA53P1-12, 13, 31, 32 XA53P1-12, 13, 31, 32	*L *L
4 26	-15V HSP	-15V TTL (HIGH TRUE)	XA56P1-15, 30 XA57P1-13	*L *I
5 27	SYTM COIL -/-40V SYTM COIL -/-40V	-40V/-40V -40V/-40V	A62J18-12/XA53P1-11, 30 A62J18-12/XA53P1-11, 30	H H
6 28	GMD GND	0V 0V	A62 STAR GND A62 STAR GND	*L *L
7 29	1.4V/GHZ WBAND	C TTL (LOW TRUE)	XA24P1-6 XA27P1-43	 B
8 30	WYTMCTL WYTMSLP	TTL (LOW TRUE) TTL (LOW TRUE)	XA27P1-14 XA27P1-44	I C
9 31	HLB0	TTL (HIGH TRUE)	XA27P1-46	*I
10 32	RSTAT HLB1	TTL (LOW TRUE) TTL (HIGH TRUE)	XA27P1-45 XA27P1-16	NOT USED *I
11 33	DB0 HLB2	TTL TTL (HIGH TRUE)	*XA60P1-20 XA27P1-47	*NOT USED *I
12 34	DB2 DB1	TTL TTL	*XA60P1-21 *XA60P1-76	*NOT USED *NOT USED
13 35	DB4 DB3	TTL TTL	*XA60P1-22 *XA60P1-77	*B C I *B C I
14 36	DB6 DB5	TTL TTL	*XA60P1-23 *XA60P1-78	*B C *B C I
15 37	DB8 DB7	TTL TTL	*XA60P1-24 *XA60P1-79	*B C *B C
16 DB10 38	TTL DB9	*XA60P1-25 TTL	*B C *XA60P1-80	 *B C
17 39	+1 0V/GHZ +1 0V/GHZ RTN	1 0V/GHZ 0V	F F	A62J31-27 A62J31-13
18 40	HENDKICK - 25V/GHZ	TTL (HIGH TRUE) - 25V/GHZ	I E	XA24P1-31 *B C F H
19 41	SYTMDB YOKICK	-22V TO -39V TTL (HIGH TRUE)	H XA54P1-21	A62J32-2 I
20 42	SYTMDC SYTM COIL +	-.6V TO -6V -40V TO -25V	H H	A62J32-4 *
21 43	RGND RGND	0V 0V	STAR GND POINT STAR GND POINT	*L *L
22 44	PRETUNE SYTMRES	-2 5V/GHZ 0V \cong 2 GHZ - 9V LOW BAND CW	XA54P1-24 H	*C D E J A62J32-5

A single letter in the source or destination column refers to a function block on this assembly schematic.

An asterisk (*) denotes multiple sources or destinations; refer to the A62 motherboard wiring list for a complete representation of signal sources and destinations

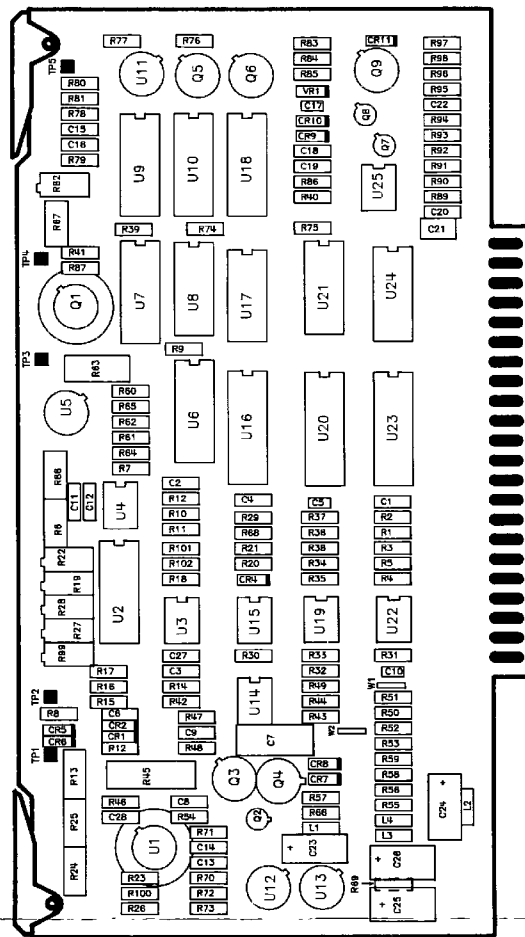

HP Part Number: 08340-60256

Figure A28-3. A28 SYTM Driver Component Location Diagram
A28-8 RF Section

NOTES:
1. RESISTANCE VALUES ARE IN OHMS,
CAPACITANCE IN MICROFARADS, AND
INDUCTANCE IN MICROHENRIES UNLESS
OTHERWISE NOTED.

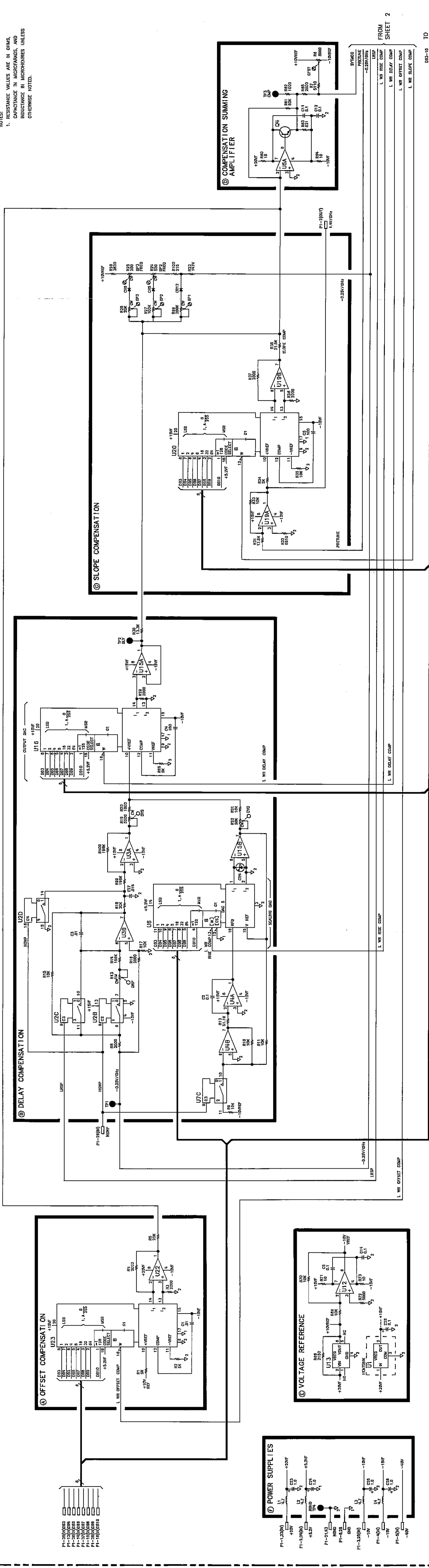

- NOTES
1. RESISTANCE VALUES ARE IN OHMS, CAPACITANCE IN MICROFARADS, AND INDUCTANCE IN MICROHENRIES UNLESS OTHERWISE NOTED.
 2. INSERT JUMPERS W1 AND W2 FOR 1.0V/GRH OUTPUT, 0.5V/GRH CONFIGURATION IS STANDARD.

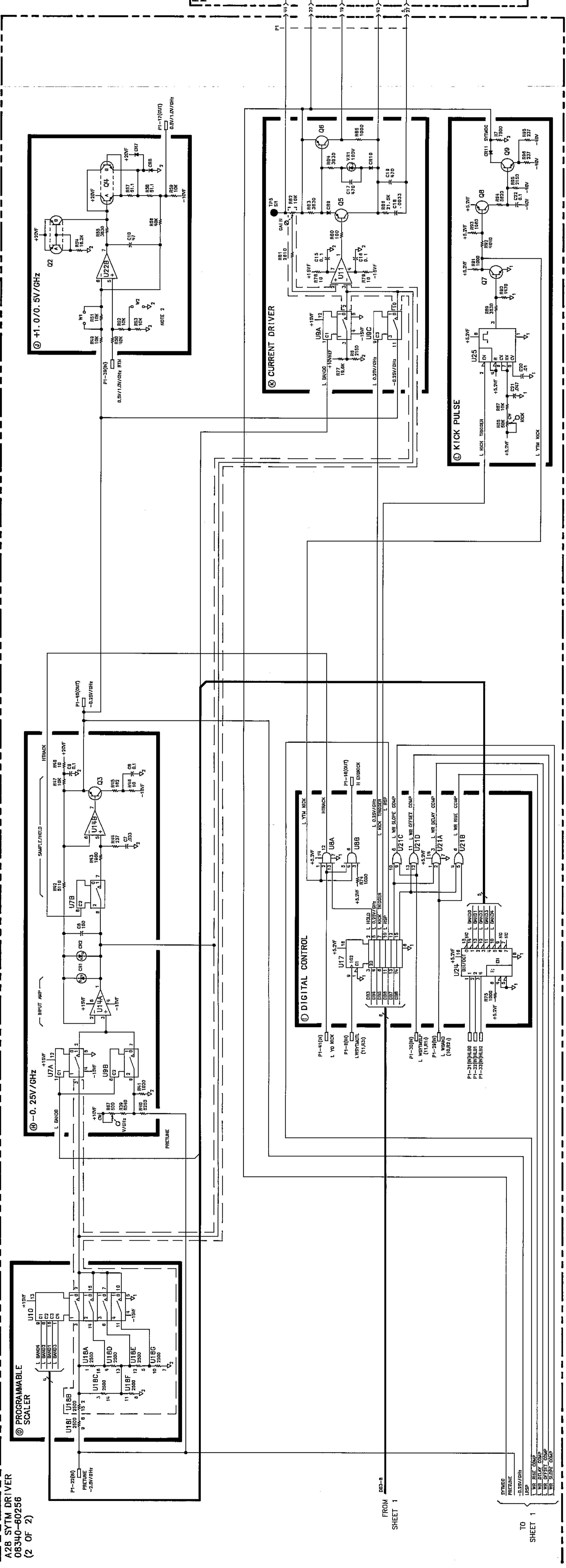

Figure A28-4. A28 SYTM Driver Schematic (2 of 2)
RF Section
A28-11/A28-12

A28 SYTM Driver Component-Level Troubleshooting

Table A28-2. SYTM Driver Replaceable Parts

Reference Designation	HP Part Number	C D	Qty	Description	Mfr Code	Mfr Part Number
A28	08340-60256	7	1	SYTM DRIVER ASSEMBLY	28480	08340-60256
A28C1	0160-4832	4	3	CAPACITOR-FXD 01UF ±10% 100VDC CER	28480	0160-4832
A28C2	0160-4841	5	12	CAPACITOR-FXD 1UF +80-20% 50VDC CER	28480	0160-4841
A28C3	0160-4841	5		CAPACITOR-FXD 1UF +80-20% 50VDC CER	28480	0160-4841
A28C4	0160-4801	7	4	CAPACITOR-FXD 100PF ±5% 100VDC CER	28480	0160-4801
A28C5	0160-4801	7		CAPACITOR-FXD 100PF ±5% 100VDC CER	28480	0160-4801
A28C6	0160-4801	7		CAPACITOR-FXD 100PF ±5% 100VDC CER	28480	0160-4801
A28C7	0160-0163	6	1	CAPACITOR-FXD 033UF ±10% 200VDC POLYE	28480	0160-0163
A28C8	0160-4841	5		CAPACITOR-FXD 1UF +80-20% 50VDC CER	28480	0160-4841
A28C9	0160-4841	5		CAPACITOR-FXD 1UF +80-20% 50VDC CER	28480	0160-4841
A28C10	0160-4805	1	1	CAPACITOR-FXD 47PF ±5% 100VDC CER 0±30	28480	0160-4805
A28C11	0160-4841	5		CAPACITOR-FXD 1UF +80-20% 50VDC CER	28480	0160-4841
A28C12	0160-4841	5		CAPACITOR-FXD 1UF +80-20% 50VDC CER	28480	0160-4841
A28C13	0160-4841	5		CAPACITOR-FXD 1UF +80-20% 50VDC CER	28480	0160-4841
A28C14	0160-4841	5		CAPACITOR-FXD 1UF +80-20% 50VDC CER	28480	0160-4841
A28C15	0160-4841	5		CAPACITOR-FXD 1UF +80-20% 50VDC CER	28480	0160-4841
A28C16	0160-4841	5		CAPACITOR-FXD 1UF +80-20% 50VDC CER	28480	0160-4841
A28C17	0160-4801	7		CAPACITOR-FXD 100PF ±5% 100VDC CER	28480	0160-4801
A28C18	0160-4833	5	1	CAPACITOR-FXD 022UF ±10% 100VDC CER	28480	0160-4833
A28C19	0160-4822	2	1	CAPACITOR-FXD 1000PF ±5% 100VDC CER	28480	0160-4822
A28C20	0160-4832	4		CAPACITOR-FXD 01UF ±10% 100VDC CER	28480	0160-4832
A28C21	0160-4834	6	1	CAPACITOR-FXD 047UF ±10% 100VDC CER	28480	0160-4834
A28C22	0160-4841	5		CAPACITOR-FXD 1UF +80-20% 50VDC CER	28480	0160-4841
A28C23	0180-0269	5	4	CAPACITOR-FXD 1UF+50-10% 150VDC AL	56289	30D105G150BA2
A28C24	0180-0269	5		CAPACITOR-FXD 1UF+50-10% 150VDC AL	56289	30D105G150BA2
A28C25	0180-0269	5		CAPACITOR-FXD 1UF+50-10% 150VDC AL	56289	30D105G150BA2
A28C26	0180-0269	5		CAPACITOR-FXD 1UF+50-10% 150VDC AL	56289	30D105G150BA2
A28C27	0160-4832	4		CAPACITOR-FXD 01UF ±10% 100VDC CER	28480	0160-4832
A28C28	0160-4841	5		CAPACITOR-FXD 1UF +80-20% 50VDC CER	28480	0160-4841
A28CR1	1901-0518	8	3	DIODE-SM SIG SCHOTTKY	28480	1901-0518
A28CR2	1901-0518	8		DIODE-SM SIG SCHOTTKY	28480	1901-0518
A28CR3				NOT ASSIGNED		
A28CR4	1901-0518	8		DIODE-SM SIG SCHOTTKY	28480	1901-0518
A28CR5	1901-0050	3	8	DIODE-SWITCHING 80V 200MA 2NS DO-35	28480	1901-0050
A28CR6	1901-0050	3		DIODE-SWITCHING 80V 200MA 2NS DO-35	28480	1901-0050
A28CR7	1901-0050	3		DIODE-SWITCHING 80V 200MA 2NS DO-35	28480	1901-0050
A28CR8	1901-0050	3		DIODE-SWITCHING 80V 200MA 2NS DO-35	28480	1901-0050
A28CR9	1901-0050	3		DIODE-SWITCHING 80V 200MA 2NS DO-35	28480	1901-0050
A28CR10	1901-0050	3		DIODE-SWITCHING 80V 200MA 2NS DO-35	28480	1901-0050
A28CR11	1901-0050	3		DIODE-SWITCHING 80V 200MA 2NS DO-35	28480	1901-0050
A28CR12	1901-0050	3		DIODE-SWITCHING 80V 200MA 2NS DO-35	28480	1901-0050
A28L1	9140-0144	0	4	INDUCTOR RF-CH-MLD 4 7UH 10% 105DX 26LG	28480	9140-0144
A28L2	9140-0144	0		INDUCTOR RF-CH-MLD 4 7UH 10% 105DX 26LG	28480	9140-0144
A28L3	9140-0144	0		INDUCTOR RF-CH-MLD 4 7UH 10% 105DX 26LG	28480	9140-0144
A28L4	9140-0144	0		INDUCTOR RF-CH-MLD 4 7UH 10% 105DX 26LG	28480	9140-0144
A28MP1	1205-0011	0	2	HEAT SINK TO-5/TO-39-CS	28480	1205-0011
A28MP2	1480-0073	6	2	PIN-ROLL 062-IN-DIA 25-IN-LG BE-CU	28480	1480-0073
A28MP3	4040-0750	7	1	EXTR-PC BD RED POLYC 062-BD-THKNS	28480	4040-0750
A28MP4	4040-0747	2	1	EXTR-PC BD GRA POLYC 062-BD-THKNS	28480	4040-0747
A28Q1	1854-0361	8	2	TRANSISTOR NPN 2N4239 SI TO-5 PD=6W	04713	2N4239
A28Q2	1853-0316	1	1	TRANSISTOR-DUAL PNP PD=500MW	28480	1853-0316
A28Q3	1853-0038	4	3	TRANSISTOR PNP SI TO-39 PD=1W FT=100MHZ	28480	1853-0038
A28Q4	1854-0475	5	1	TRANSISTOR-DUAL NPN PD=750MW	28480	1854-0475
A28Q5	1853-0038	4		TRANSISTOR PNP SI TO-39 PD=1W FT=100MHZ	28480	1853-0038
A28Q6	1853-0038	4		TRANSISTOR PNP SI TO-39 PD=1W FT=100MHZ	28480	1853-0038
A28Q7	1854-0477	7	1	TRANSISTOR NPN 2N2222A SI TO-18 PD=500MW	04713	2N2222A
A28Q8	1853-0281	9	1	TRANSISTOR PNP 2N2907A SI TO-18 PD=400MW	04713	2N2907A
A28Q9	1854-0361	8		TRANSISTOR NPN 2N4239 SI TO-5 PD=6W	04713	2N4239
A28R1	0698-6320	8	6	RESISTOR 5K 1% 125W F TC=0±25	28480	0698-6320
A28R2	0698-6320	8		RESISTOR 5K 1% 125W F TC=0±25	28480	0698-6320
A28R3	0698-6624	5	8	RESISTOR 2K 1% 125W F TC=0±25	28480	0698-6624
A28R4	0698-6624	5		RESISTOR 2K 1% 125W F TC=0±25	28480	0698-6624
A28R5	0698-6627	8	1	RESISTOR 25K 1% 125W F TC=0±25	28480	0698-6627
A28R6	2100-3207	1	1	RESISTOR-TRMR 5K 10% C SIDE-ADJ 1-TRN	28480	2100-3207
A28R7	0757-0438	3	2	RESISTOR 5 11K 1% 125W F TC=0±100	24546	C4-1/8-T0-5111-F
A28R8	0698-6624	5		RESISTOR 2K 1% 125W F TC=0±25	28480	0698-6624
A28R9	0757-0442	9	9	RESISTOR 10K 1% 125W F TC=0±100	24546	C4-1/8-T0-1002-F
A28R10	0757-0442	9		RESISTOR 10K 1% 125W F TC=0±100	24546	C4-1/8-T0-1002-F

A28 SYTM Driver Component-Level Troubleshooting

Table A28-2 A28 SYTM Driver Replaceable Parts

Reference Designation	HP Part Number	C D	Qty	Description	Mfr Code	Mfr Part Number
A28R11	0757-0442	9		RESISTOR 10K 1% 125W F TC=0±100	24546	C4-1/8-T0-1002-F
A28R12	0757-0458	7	1	RESISTOR 51 1K 1% 125W F TC=0±100	24546	C4-1/8-T0-5112-F
A28R13	2100-3358	3	1	RESISTOR-TRMR 1M 20% C SIDE-ADJ 1-TRN	28480	2100-3358
A28R14	0698-3453	2	3	RESISTOR 196K 1% 125W F TC=0±100	24546	C4-1/8-T0-1963-F
A28R15	0698-6360	6	8	RESISTOR 10K 1% 125W F TC=0±25	28480	0698-6360
A28R16	0698-6624	5		RESISTOR 2K 1% 125W F TC=0±25	28480	0698-6624
A28R17	0698-6360	6		RESISTOR 10K 1% 125W F TC=0±25	28480	0698-6360
A28R18	0698-6630	3	1	RESISTOR 20K 1% 125W F TC=0±25	28480	0698-6630
A28R19	2100-3739	6	1	RESISTOR-TRMR 5K 10% C SIDE-ADJ 17-TRN	32997	3292X-1-5001
A28R20	0757-0280	3	7	RESISTOR 1K 1% 125W F TC=0±100	24546	C4-1/8-T0-1001-F
A28R21	0757-0442	9		RESISTOR 10K 1% 125W F TC=0±100	24546	C4-1/8-T0-1002-F
A28R22	2100-3611	1	1	RESISTOR-TRMR 50K 10% C SIDE-ADJ 17-TRN	32997	3292X-1-5002
A28R23	0757-1094	9	2	RESISTOR 1 47K 1% 125W F TC=0±100	24546	C4-1/8-T0-1471-F
A28R24	2100-3351	6	2	RESISTOR-TRMR 500 10% C SIDE-ADJ 1-TRN	28480	2100-3351
A28R25	2100-3350	5	1	RESISTOR-TRMR 200 10% C SIDE-ADJ 1-TRN	28480	2100-3350
A28R26	0698-3153	9	4	RESISTOR 3 83K 1% 125W F TC=0±100	24546	C4-1/8-T0-3831-F
A28R27	2100-0544	3	1	RESISTOR-TRMR 100K 10% C SIDE-ADJ 17-TRN	32997	3292X-1-104
A28R28	2100-3750	9	1	RESISTOR-TRMR 20K 10% C SIDE-ADJ 17-TRN	28480	2100-3750
A28R29	0698-6624	5		RESISTOR 2K 1% 125W F TC=0±25	28480	0698-6624
A28R30	0757-0289	3	1	RESISTOR 13 3K 1% 125W F TC=0±100	24546	C4-1/8-T0-1332-F
A28R31	0698-3136	8	1	RESISTOR 17 8K 1% 125W F TC=0±100	24546	C4-1/8-T0-1782-F
A28R32	0757-0439	4	1	RESISTOR 6 81K 1% 125W F TC=0±100	24546	C4-1/8-T0-6811-F
A28R33	0757-0442	9		RESISTOR 10K 1% 125W F TC=0±100	24546	C4-1/8-T0-1002-F
A28R34	0698-6320	8		RESISTOR 5K 1% 125W F TC=0±25	28480	0698-6320
A28R35	0698-6320	8		RESISTOR 5K 1% 125W F TC=0±25	28480	0698-6320
A28R36	0698-6624	5		RESISTOR 2K 1% 125W F TC=0±25	28480	0698-6624
A28R37	0698-6624	5		RESISTOR 2K 1% 125W F TC=0±25	28480	0698-6624
A28R38	0757-0199	3	1	RESISTOR 21 5K 1% 125W F TC=0±100	24546	C4-1/8-T0-2152-F
A28R39	0698-6406	1	1	RESISTOR 8 54K 1% 1W F TC=0+4	28480	0698-6406
A28R40	0698-8061	8	1	RESISTOR 8 25K 1% 125W F TC=0±25	19701	MF4C1/8-T9-8251-B
A28R41	0698-8498	5	1	RESISTOR 1 02K 1% 125W F TC=0±25	28480	0698-8498
A28R42	0757-0438	3		RESISTOR 5 11K 1% 125W F TC=0±100	24546	C4-1/8-T0-5111-F
A28R43	0698-0083	8		RESISTOR 1 96K 1% 125W F TC=0±100	24546	C4-1/8-T0-1961-F
A28R44	0698-3442	9	3	RESISTOR 237 1% 125W F TC=0±100	24546	C4-1/8-T0-237R-F
A28R45	0757-0802	5	1	RESISTOR 162 1% 5W F TC=0±100	28480	0757-0802
A28R46	0757-0346	2	8	RESISTOR 10 1% 125W F TC=0±100	24546	C4-1/8-T0-10R0-F
A28R47	0757-0442	9		RESISTOR 10K 1% 125W F TC=0±100	24546	C4-1/8-T0-1002-F
A28R48	0757-0346	2		RESISTOR 10 1% 125W F TC=0±100	24546	C4-1/8-T0-10R0-F
A28R49	0698-6360	6		RESISTOR 10K 1% 125W F TC=0±25	28480	0698-6360
A28R50	0698-6363	9	2	RESISTOR 40K 1% 125W F TC=0±25	28480	0698-6363
A28R51	0698-6360	6		RESISTOR 10K 1% 125W F TC=0±25	28480	0698-6360
A28R52	0698-6360	6		RESISTOR 10K 1% 125W F TC=0±25	28480	0698-6360
A28R53	0698-6360	6		RESISTOR 10K 1% 125W F TC=0±25	28480	0698-6360
A28R54	0757-0447	4	1	RESISTOR 16 2K 1% 125W F TC=0±100	24546	C4-1/8-T0-1622-F
A28R55	0698-3153	9		RESISTOR 3 83K 1% 125W F TC=0±100	24546	C4-1/8-T0-3831-F
A28R56	0698-6363	9		RESISTOR 40K 1% 125W F TC=0±25	28480	0698-6363
A28R57	0757-0394	0	2	RESISTOR 51 1 1% 125W F TC=0±100	24546	C4-1/8-T0-51R1-F
A28R58	0757-0394	0		RESISTOR 51 1 1% 125W F TC=0±100	24546	C4-1/8-T0-51R1-F
A28R59	0757-0442	9		RESISTOR 10K 1% 125W F TC=0±100	24546	C4-1/8-T0-1002-F
A28R60	0757-0346	2		RESISTOR 10 1% 125W F TC=0±100	24546	C4-1/8-T0-10R0-F
A28R61	0698-6353	7	1	RESISTOR 50K 1% 125W F TC=0±25	28480	0698-6353
A28R62	0757-0280	3		RESISTOR 1K 1% 125W F TC=0±100	24546	C4-1/8-T0-1001-F
A28R63	0698-3637	4	1	RESISTOR 620 5% 2W MO TC=0±200	28480	0698-3637
A28R64	0757-0346	2		RESISTOR 10 1% 125W F TC=0±100	24546	C4-1/8-T0-10R0-F
A28R65	0698-6624	5		RESISTOR 2K 1% 125W F TC=0±25	28480	0698-6624
A28R66	0698-0084	9	3	RESISTOR 2 15K 1% 125W F TC=0±100	24546	C4-1/8-T0-2151-F
A28R67	2100-3351	6		RESISTOR-TRMR 500 10% C SIDE-ADJ 1-TRN	28480	2100-3351
A28R68	0698-6320	8		RESISTOR 5K 1% 125W F TC=0±100	24546	C4-1/8-T0-5001-F
A28R69	0698-6360	6		RESISTOR 10K 1% 125W F TC=0±25	28480	0698-6360
A28R70	0698-6360	6		RESISTOR 10K 1% 125W F TC=0±25	28480	0698-6360
A28R71	0757-0346	2		RESISTOR 10 1% 125W F TC=0±100	24546	C4-1/8-T0-10R0-F
A28R72	0698-6320	8		RESISTOR 5K 1% 125W F TC=0±25	03888	PME55-1/8-T9-5001-B
A28R73	0757-0346	2		RESISTOR 10 1% 125W F TC=0±100	24546	C4-1/8-T0-10R0-F
A28R74	0757-0280	3		RESISTOR 1K 1% 125W F TC=0±100	24546	C4-1/8-T0-1001-F
A28R75	0757-0280	3		RESISTOR 1K 1% 125W F TC=0±100	24546	C4-1/8-T0-1001-F
A28R76	0698-0084	9		RESISTOR 2 15K 1% 125W F TC=0±100	24546	C4-1/8-T0-2151-F
A28R77	0698-3157	3	1	RESISTOR 19 6K 1% 125W F TC=0±100	24546	C4-1/8-T0-1962-F
A28R78	0757-0346	2		RESISTOR 10 1% 125W F TC=0±100	24546	C4-1/8-T0-10R0-F
A28R79	0757-0346	2		RESISTOR 10 1% 125W F TC=0±100	24546	C4-1/8-T0-10R0-F
A28R80	0757-0401	0	1	RESISTOR 100 1% 125W F TC=0±100	24546	C4-1/8-T0-101-F

A28 SYTM Driver Component-Level Troubleshooting

Table A28-2. A28 SYTM Driver Replaceable Parts

Reference Designation	HP Part Number	C D	Qty	Description	Mfr Code	Mfr Part Number
A28R81	0698-0085	0	1	RESISTOR 2 61K 1% 125W F TC=0±100	24546	C4-1/8-T0-2611-F
A28R82	2100-0670	6		RESISTOR-TRMR 10K 10% C SIDE-ADJ 17-TRN	32997	3292Y-1-103
A28R83	0698-3153	9		RESISTOR 3 83K 1% 125W F TC=0±100	24546	C4-1/8-T0-3831-F
A28R84	0757-0280	3		RESISTOR 1K 1% 125W F TC=0±100	24546	C4-1/8-T0-1001-F
A28R85	0757-0280	3		RESISTOR 1K 1% 125W F TC=0±100	24546	C4-1/8-T0-1001-F
A28R86	0757-0442	9		RESISTOR 10K 1% 125W F TC=0±100	24546	C4-1/8-T0-1002-F
A28R87	0757-0442	9		RESISTOR 10K 1% 125W F TC=0±100	24546	C4-1/8-T0-1002-F
A28R88	2100-3354	9	1	RESISTOR-TRMR 50K 10% C SIDE-ADJ 1-TRN	28480	2100-3354
A28R89	0698-3153	9		RESISTOR 3 83K 1% 125W F TC=0±100	24546	C4-1/8-T0-3831-F
A28R90	0757-1094	9		RESISTOR 1 47K 1% 125W F TC=0±100	24546	C4-1/8-T0-1471-F
A28R91	0757-0280	3		RESISTOR 1K 1% 125W F TC=0±100	24546	C4-1/8-T0-1001-F
A28R92	0698-3155	1	1	RESISTOR 4 64K 1% 125W F TC=0±100	24546	C4-1/8-T0-4641-F
A28R93	0698-0083	8		RESISTOR 1 96K 1% 125W F TC=0±100	24546	C4-1/8-T0-1961-F
A28R94	0757-0200	7	1	RESISTOR 5 62K 1% 125W F TC=0±100	24546	C4-1/8-T0-5621-F
A28R95	0698-0084	9		RESISTOR 2 15K 1% 125W F TC=0±100	24546	C4-1/8-T0-2151-F
A28R96	0698-3442	9		RESISTOR 237 1% 125W F TC=0±100	24546	C4-1/8-T0-237R-F
A28R97	0757-0440	7	1	RESISTOR 7 5K 1% 125W F TC=0±100	24546	C4-1/8-T0-7501-F
A28R98	0698-3442	9		RESISTOR 237 1% 125W F TC=0±100	24546	C4-1/8-T0-237R-F
A28R99	2100-3753	2	1	RESISTOR-TRMR 200K 10% C SIDE-ADJ 17-TRN	28480	2100-3753
A28R100	0698-3441	8	1	RESISTOR 215 1% 125W F TC=0±100	24546	C4-1/8-T0-215R-F
A28R101	0698-3453	2		RESISTOR 196K 1% 125W F TC=0±100	24546	C4-1/8-T0-1963-F
A28R102	0698-3453	2		RESISTOR 196K 1% 125W F TC=0±100	24546	C4-1/8-T0-1963-F
A28TP1	0360-0535	0	5	TERMINAL-TEST POINT 330IN ABOVE	28480	0360-0535
A28TP2	0360-0535	0		TERMINAL-TEST POINT 330IN ABOVE	28480	0360-0535
A28TP3	0360-0535	0		TERMINAL-TEST POINT 330IN ABOVE	28480	0360-0535
A28TP4	0360-0535	0		TERMINAL-TEST POINT 330IN ABOVE	28480	0360-0535
A28TP5	0360-0535	0		TERMINAL-TEST POINT 330IN ABOVE	28480	0360-0535
A28U1	1826-0512	2	1	IC V RGLTR-FXD-POS 14 4/15 6V TO-39 PKG	28480	1826-0512
A28U2	1826-0811	4	3	IC SWITCH ANLG QUAD 16-DIP-C PKG	06665	SW-01FQ
A28U3	1826-0785	1	6	IC OP AMP LOW-BIAS-H-IMP DUAL 8-DIP-C	01295	TL072ACJG
A28U4	1826-0785	1		IC OP AMP LOW-BIAS-H-IMP DUAL 8-DIP-C	01295	TL072ACJG
A28U5	1826-0471	2	3	IC OP AMP LOW-DRIFT TO-99 PKG	06665	OP-07CJ SELECTED
A28U6	1826-0699	6	1	IC CONV 8-B-D/A 16-DIP-C PKG	24355	AD7524AD
A28U7	1826-0720	4	1	IC SWITCH ANLG QUAD 16-DIP-C PKG	06665	SW-02FQ
A28U8	1820-1203	8	1	IC GATE TTL LS AND TPL 3-INP	01295	SN74LS11N
A28U9	1826-0811	4		IC SWITCH ANLG QUAD 16-DIP-C PKG	06665	SW-01FQ
A28U10	1826-0811	4		IC SWITCH ANLG QUAD 16-DIP-C PKG	06665	SW-01FQ
A28U11	1826-0471	2		IC OP AMP LOW-DRIFT TO-99 PKG	06665	OP-07CJ SELECTED
A28U12	1826-0471	2		IC OP AMP LOW-DRIFT TO-99 PKG	06665	OP-07CJ SELECTED
A28U13	1826-0853	4	1	IC V RGLTR-V-REF-FXD 9 95/10 05V TO-99	28480	1826-0853
A28U14	1826-0785	1		IC OP AMP LOW-BIAS-H-IMP DUAL 8-DIP-C	01295	TL072ACJG
A28U15	1826-0785	1		IC OP AMP LOW-BIAS-H-IMP DUAL 8-DIP-C	01295	TL072ACJG
A28U16	1826-1174	4	3	D/A 8-BIT 20-DIP-C	28480	1826-1174
A28U17	1820-2056	1	1	IC FF TTL LS D-TYPE POS-EDGE-TRIG COM	01295	SN74LS378N
A28U18	1810-0535	6	1	NETWORK-RES 16-DIP2 5K OHM x 8	28480	1810-0535
A28U19	1826-0785	1		IC OP AMP LOW-BIAS-H-IMP DUAL 8-DIP-C	01295	TL072ACJG
A28U20	1826-1174	4		D/A 8-BIT 20-DIP-C	28480	1826-1174
A28U21	1820-2657	8	1	IC GATE TTL ALS OR QUAD 2-INP	01295	SN74ALS32N
A28U22	1826-0785	1		IC OP AMP LOW-BIAS-H-IMP DUAL 8-DIP-C	01295	TL072ACJG
A28U23	1826-1174	4		D/A 8-BIT 20-DIP-C	28480	1826-1174
A28U24	1820-1216	3	1	IC DCDR TTL LS 3-TO-8-LINE 3-INP	01295	SN74LS138N
A28U25	1826-0180	0	1	IC TIMER TTL MONO/ASTBL	18324	NE555N
A28VR1	1902-0175	5	1	DIODE-ZNR 100V 5% PD=1W IR=5UA	28480	1902-0175
A28W1	1460-1489	8	2	WIREFORM BE CU AG	28480	1460-1489
A28W2	1460-1489	8		WIREFORM BE CU AG	28480	1460-1489
A28A1	1251-2194	1	4	CONNECTOR-SGL CONT SKT 021-IN-BSC-SZ	28480	1251-2194

Power Supplies Component-Level Service I

CONTENTS

A19 CAPACITOR ASSEMBLY

CIRCUIT DESCRIPTION	A19-1
Assembly Purpose	A19-1
+20V Rectifier (Block A)	A19-1
–10V Rectifier (Block B)	A19-1
Power-On Safety Indicator (Block C)	A19-1
TROUBLESHOOTING	A19-2
The Power-On Safety Indicator (DS1)	A19-2
Capacitor Replacement	A19-2
If the Main Line Fuse Blows	A19-3
If the +20V Rectifier Output Voltage is Incorrect	A19-3
If the –10V Rectifier Output Voltage is Incorrect	A19-4

A35 RECTIFIER

CIRCUIT DESCRIPTION	A35-1
Assembly Purpose	A35-1
–40V Rectifier (Block A)	A35-1
Overvoltage Protection (Block B)	A35-1
+5V Rectifier (Block C)	A35-1
+22V Regulator (Block D)	A35-1
+22V Crowbar/Supply-On Indicator (Block E)	A35-2
Power from the Motherboard	A35-2
Power Supply Heat Sink	A35-2
TROUBLESHOOTING	A35-3
How to Apply Thermal Compound	A35-3
–40V Rectifier	A35-4
+5V Rectifier	A35-4
+22V Regulator	A35-4
How to Determine Supply/Load Failure	A35-4
+22V Load Failure	A35-5
+22V Power Supply Failure	A35-5
A19 Capacitor Assembly P1 Pin I/O	A35-7
A35 Rectifier P1 Pin I/O	A35-8
A19 Capacitor Assembly Component Location Diagram	A35-9
A35 Rectifier Component Location Diagram	A35-10
A19 Capacitor Assembly, A35 Rectifier Assembly Schematic Diagram	A35-11
A19 Capacitor Assembly Replaceable Parts	A35-13
A35 Rectifier Assembly Replaceable Parts	A35-15

CONTENTS (Cont'd)

A52 POSITIVE REGULATOR

CIRCUIT DESCRIPTION	A52-1
Assembly Purpose	A52-1
+10V/+4 9V Reference (Block A)	A52-1
+20V Regulator (Block B)	A52-1
+20V Crowbar/Supply On Indicator (Block C)	A52-2
Reference Oscillator Supply (Block D)	A52-3
Standby/Overtemp Shutdown (Block E)	A52-3
Grounds and Commons (Block F)	A52-3
+5.2V Regulator (Block G)	A52-3
+5.2V Crowbar/Protection (Block H)	A52-4
Microprocessor Protection (Block I)	A52-4
+12V Regulator (Block J)	A52-4
+12V Crowbar/Power On Indicator (Block K)	A52-4
Voltage Sense (Block L)	A52-4
TROUBLESHOOTING	A52-5
How to Apply Thermal Compound	A52-5
If All Supplies Are Down	A52-6
How to Determine Supply/Load Failure	A52-6
+20V Load Failure	A52-7
+20V Power Supply Failure	A52-7
+12V Regulator	A52-9
+12V Power Supply Failure	A52-9
Reference Oscillator Supply	A52-10
+5.2 Regulator	A52-10
+5.2V Power Supply Failure	A52-11
A52 Positive Regulator P1 Pin I/O	A52-13
A52 Positive Regulator Component Location Diagram	A52-14
A52 Positive Regulator Schematic Diagram	A52-15
A52 Positive Regulator Replaceable Parts	A52-17

A53 NEGATIVE REGULATOR

CIRCUIT DESCRIPTION	A53-1
Assembly Purpose	A53-1
-10V Regulator (Block A)	A53-1
-10V Crowbar/Supply On Indicator	A53-1
-5.2V Regulator (Block C)	A53-1
-5.2V Crowbar/Supply On Indicator (Block D)	A53-2
-40V Regulator (Block E)	A53-2
-40V Crowbar/Supply On Indicator (Block F)	A53-2
Voltage Sense (Block H)	A53-2
Grounds and Commons (Block I)	A53-2
TROUBLESHOOTING	A53-3
How to Apply Thermal Compound	A53-4
-10V Regulator	A53-4
Supply/Load Failure Determination	A53-4
-10V Load Failure	A53-5
-10V Power Supply Failure	A53-5
-40V Regulator	A53-7
-5.2V Regulator	A53-7
-5.2V Power Supply Failure	A53-7

CONTENTS (Cont'd)

A56 – 15V REGULATOR

CIRCUIT DESCRIPTION	A56-1
Assembly Purpose	A56-1
–15V Regulator (Block A)	A56-1
–15V Crowbar/Supply On Indicator (Block B)	A56-1
Low Voltage Sense (Block C)	A56-1
TROUBLESHOOTING	A56-2
How to Apply Thermal Compound	A56-2
A53 Negative Regulator P1 Pin I/O	A56-4
A56 –15V Regulator P1 Pin I/O	A56-5
A53 Negative Regulator Component Location Diagram	A56-6
A56 –15V Regulator Component Location Diagram	A56-8
A53 Negative Regulator and A56 –15V Regulator Schematic Diagram	A56-9
A53 Negative Regulator Replaceable Parts	A56-11
A56 –15V Regulator Replaceable Parts	A56-13

A19 Capacitor Assembly Circuit Description

ASSEMBLY PURPOSE

The A19 capacitor assembly contains the full-wave bridge rectifiers and line filters for the +20V and -10V power supplies. Also located on this assembly is a power-on safety indicator. When this indicator is illuminated, (see block C, below), there are hazardous voltages present on the A62 motherboard.

+20V RECTIFIER (BLOCK A)

The +20V full-wave bridge rectifier consists of CR1 through CR4. A high frequency filter suppresses conducted line emissions by attenuating diode reverse recovery transients. A capacitor decreases the high frequency currents on the +20V UNREG line.

-10V RECTIFIER (BLOCK B)

The -10V full-wave bridge rectifier includes schottky barrier power rectifiers, which increase the efficiency of the low voltage power supplies. A high frequency filter suppresses conducted line emissions. A capacitor decreases the high frequency currents on the -10V UNREG line.

POWER-ON SAFETY INDICATOR (BLOCK C)

The POWER-ON LED (DS1) is on when the unregulated supply filter capacitors contain enough energy to present a potential safety hazard. Because the instrument has no on/off line power switch, if the instrument is plugged in to ac line power, the unregulated supplies and +22V regulated supply are active.

A19 Capacitor Assembly Component-Level Troubleshooting

WARNING

When the instrument is connected to ac line power and/or the A19 power-on safety indicator LED is on, there are voltages present inside the instrument that can cause personal injury or death. Only qualified personnel, who are aware of the hazards involved, should perform service on this instrument with its protective covers removed.

CAUTION

The crowbar circuitry on this assembly protects the instrument, do not operate the supply without it.

To avoid non-repairable damage to assemblies, do not reinstall the A19, A35, A52, or A53 assemblies unless ac mains is disconnected from the instrument.

To protect static sensitive components, troubleshoot this assembly only at a work station equipped with an anti-static surface, and wear a grounding strap. When handling a printed circuit board, hold it by the edges; never touch the finger contacts.

Never short a capacitor with a screwdriver or other direct short.

THE POWER-ON SAFETY INDICATOR (DS1)

When the power-on safety indicator LED is on, hazardous voltages exist on the A62 motherboard. Wait for this LED to go out before removing the A19 assembly. The A19 extender board is designed to be used with the instrument is on its left side (ON/STANDBY switch down, output connector up), with the A19 assembly resting on the side rail.

CAPACITOR REPLACEMENT

When you replace an electrolytic capacitor, place the capacitor's pressure relief valve directly over the hole in the PC board. This ensures correct capacitor polarity.

IF THE MAIN LINE FUSE BLOWS

Remove the aluminum electrolytic capacitors C5 through C9.

- If the problem disappears, one of these capacitors is shorted. Use a process of elimination to discover the defective capacitor.
- If the problem persists, try to isolate the cause to one of the two rectifier circuits as follows:
 1. The transformer secondary windings that power the rectifiers go first to the A62 motherboard where they are attached with screws. Unplug the instrument from ac line power, and wait for the power-on safety indicator to go out.
 2. Remove the A19 assembly (to make the screws accessible) and remove one of the red secondary wires that power the +20V rectifier (be careful to isolate the exposed wire from all other circuits on the motherboard).
 3. Install the A19 assembly and connect the instrument to ac line power.
 4. If necessary, repeat this procedure to disconnect the -10V secondary. If either rectifier circuit is at fault, suspect a shorted component. If the problem persists, suspect an A62 motherboard short.

IF THE +20V RECTIFIER OUTPUT VOLTAGE IS INCORRECT

1. Make sure the instrument is in STANDBY and power to the instrument is nominal (120V in the 120V line option, etc.).
2. Ensure that the line voltage selector cam is installed properly.
3. Measure TP1 (or directly across C5 or C6) for +35V
 - a. If the voltage is low, unplug the instrument from ac line power and wait for the power-on safety indicator to go out.
 - b. Remove the A35 and A52 assemblies.
 - c. Connect the instrument to ac line power and measure TP1 again. If the voltage at TP1 is now approximately +35 VDC, disconnect the instrument from ac line power and wait for the power-on safety indicator to go out.
 - d. Observing all safety precautions, reinstall A35 and A52 one at a time to determine which is at fault. Refer to the appropriate troubleshooting guide.
 - e. If the problem persists after A35 and A52 are removed, suspect an open rectifier diode. If these are good, suspect the transformer.

IF THE –10V RECTIFIER OUTPUT VOLTAGE IS INCORRECT

1. Make sure the instrument is in STANDBY and power to the instrument is nominal (120V in the 120V line option, etc.).
2. Ensure that the line voltage selector cam is installed properly.
3. Check for +18 VDC directly across C7, C8, or C9.
 - a. If the voltage is low, unplug the instrument from ac line power and wait for the power-on safety indicator to go out.
 - b. Remove the A53 assembly.
 - c. Connect the instrument to ac line power and measure across the capacitor again. If the voltage is now approximately +18 VDC, disconnect the instrument from ac line power and wait for the power-on safety indicator to go out.
 - d. Observing all safety precautions, reinstall A53 to determine if it is at fault. Refer to the appropriate troubleshooting guide.
 - e. If the problem persists after A53 is removed, suspect an open rectifier diode. If these are good, suspect the transformer.
4. If DS1 is out, but the –10V UNREG voltage level appears correct, check DS1 and R3.

Table A19-1. A19 Power Supply Destinations

Power Supply	Destination Assemblies
+20V UNREG	A35, A52
–10V UNREG	A53

A35 Rectifier Circuit Description

ASSEMBLY PURPOSE

The A35 rectifier assembly consists of the following circuits:

- -40V Rectifier
- +22V Regulator
- +5V Rectifier
- Overvoltage Protection

-40V RECTIFIER (BLOCK A)

The -40V rectifier consists of CR1 through CR4. A high frequency filter decreases conducted line emissions. C5 decreases the high frequency currents on the -40V unregulated line.

OVERVOLTAGE PROTECTION (BLOCK B)

The overvoltage protection circuitry is a crowbar circuit that fires if the line voltage selector cam is set to a low line voltage and the instrument is plugged into a high voltage outlet. This circuit blows the main fuse in the line module.

+5V RECTIFIER (BLOCK C)

The +5V rectifier is a full-wave, center-tapped rectifier. Power rectifier U1 is a single-chip dual schottky barrier rectifier. High frequency filters decrease conducted line emissions.

+22V REGULATOR (BLOCK D)

The +22V regulator consists of a three-terminal adjustable regulator, adjustment circuitry, and ripple rejection capacitors. A protection diode prevents capacitive discharge into the regulator if the input is shorted, or when line power is removed. Output diodes protect the loads from damage due to reverse polarity power supply voltages in the event of an instrument fault.

NOTE: This supply is active as long as the instrument is connected to ac line power.

+22V CROWBAR/SUPPLY-ON INDICATOR (BLOCK E)

If there is an overvoltage condition on the regulated output, the supply is shorted to ground to protect the instrument loads. Transients are filtered out to prevent premature firing of the SCR. The power-on safety indicator lights when the regulator supply voltage reaches +17V.

The tolerance of the +22V supply is $+22V \pm 5\%$ (1.1V).

POWER FROM THE MOTHERBOARD

The A62 motherboard distributes all secondary ac and unregulated DC power to the assemblies that require them. The power-on safety indicator is active when the instrument is plugged in to ac line power, and warns that hazardous voltages are present on the motherboard in the power supply area. (The same circuit is used to generate the 60 Hz LINE TRIGGER signal for the internal sweep circuitry).

If DS1 fails to light when the instrument is connected to ac line power, first suspect a fuse failure, then an LED. An LED failure should not cause failure of the LINE TRIGGER function.

POWER SUPPLY HEAT SINK

The instrument power supply heat sink, on the rear panel, is the primary cooling system for the +20, +12, +5.2, -10, and -40V power supply series pass elements (see section E, motherboard) for placement and identity of these series pass elements on the A62 motherboard/heatsink).

A35 Rectifier Component-Level Troubleshooting

WARNING

When the instrument is plugged in to ac line power and/or the A19 power-on safety indicator LED is on, there are voltages present inside the instrument that can cause personal injury or death. Any servicing of this instrument with protective covers removed should be performed only by qualified personnel who are aware of the hazards involved.

CAUTION

The crowbar circuitry on this assembly protects the instrument, do not operate the supply without it.

To avoid non-repairable damage to assemblies, do not reinstall the A19, A35, A52, or A53 assemblies unless ac mains is disconnected from the instrument.

To protect static sensitive components, troubleshoot this assembly only at a work station equipped with an anti-static surface, and wear a grounding strap. When handling a printed circuit board, hold it by the edges; never touch the finger contacts.

The thermal connection between the voltage regulator U2, the full wave rectifier U1, and the A35 heat sink is the dominant factor in the two devices' long term reliability. when installing or replacing either of these parts. Use only oil based thermal compound (HP Part Number 6040-0454 CD0).

DO NOT use silicone based thermal compound. Silicone based oil migrates past element sockets, switch contacts, or printed circuit board edge connectors, raising contact resistance, or electrically isolating the contacts. Silicone based thermal compounds disperse into the air, depositing themselves anywhere in the instrument. Heat increases the rate of dispersion.

HOW TO APPLY THERMAL COMPOUND

When installing or replacing a pass transistor or voltage regulator, apply thermal compound as follows:

1. Apply a thin coating of thermal compound (HP Part Number 6040-0454 CD0) to both sides of the insulating washer. The coating should provide a thin but continuous layer of compound from component-to-washer and washer-to-heatsink. An excessive amount of compound reduces its ability to transfer heat

2. Tighten the pass element mounting screws with seven inch-pounds of force. Tightening with less force diminishes the heat transfer capability of the thermal compound. Tightening with greater force can damage the mounting hardware.

The A35 rectifier assembly contains three separate and isolated power circuits.

–40V RECTIFIER

When a crowbar SCR fails, it usually shorts. If the instrument blows line fuses and you trace the problem to the A35 assembly, check Q1 for a short (also check VR1). If the overvoltage protection circuit does not work, VR1 is probably open

+5V RECTIFIER

The +5V rectifier has two diodes in one package. If this unregulated supply malfunctions, check for an open or shorted diode.

+22V REGULATOR

Because the +22V regulator source is the +20V UNREG line, the A19 capacitor assembly must be present to test this regulator. The tolerance of this supply is +20.90 to +23.10V (measured at TP1).

HOW TO DETERMINE SUPPLY/LOAD FAILURE

1. Unplug the instrument from ac line power.
2. After the power-on safety indicator goes out, remove the A35 assembly and place it on an extender board.
3. Before installing the extender board in the instrument, apply thin, nonconductive tape to the extender board +22V output fingers (use colored tape, if possible, to make it highly visible, so you remember to remove it when you are through troubleshooting). **Do not** apply tape to the A35 printed circuit board fingers.
4. Reinstall the A35 assembly and connect the instrument to ac line power. If the power supply now operates properly, suspect a short on an instrument assembly that uses +22V. Refer to Table A35-1, for a list of these assemblies.
5. Remove the tape from the extender board fingers and clean the fingers using the following procedure.

How to Clean Printed Circuit Board Fingers

1. Mix one part de-ionized (or de-chlorinated) water with two parts isopropyl alcohol.
2. Apply this solution to a clean, lint free, cloth (HP Part Number 9310-0039 CD3).
3. Rub the PC board fingers carefully, then dry them with a clean part of the cloth.

+22V LOAD FAILURE

1. After performing the above procedure, and cleaning the extender board fingers, unplug the instrument from ac line power and wait for the power-on safety indicator to go out; reinstall the A35 assembly.

NOTE: Always unplug the instrument from ac line power and wait for the power-on safety indicator to go out before removing or installing any assembly or cable.

2. Remove each assembly that uses +22V, one at a time, to determine which one is faulty.
3. Remove any cables listed that carry the affected supply (see Table A35-1)

+22V POWER SUPPLY FAILURE

If the power supply output does not return to normal after you tape the extender board +22V fingers, refer to the following.

The +22V Output Voltage is Approximately 0.8 to 1.0V

1. Crowbar Circuit Verification

If the output voltage is approximately 0.8 to 1.0V the crowbar circuit is engaged.

 - a. Connect the instrument to a auto-transformer set for 0V output.
 - b. While monitoring the supply output voltage, slowly increase the auto-transformer output voltage. If the crowbar fires before the supply output reaches +22V suspect VR2.
2. Regulator Verification
 - a. If the power supply output reaches +22V, stop increasing auto-transformer voltage.
 - b. Measure the voltage across pin 1 and the case of U2 (regulator). If the voltage is not approximately 1.25V suspect U2.
 - c. Measure the voltage from the input and the output of U2. If there is little or no voltage, U2 is probably shorted.

The +22V Output Voltage is Approximately 0V

1. Initial Checks
 - a. Ensure that ac line voltage is nominal, and that the line voltage selector cam is installed properly in the line filter module, FL1.
 - b. Ensure that the proper fuse value is installed.
 - c. If the line voltage and fuse are correct, and the power supply input fuse (F1) is blown, suspect regulator U2.
2. Regulator Verification
 - a. Measure across pin 1 and the case of U2. If the voltage is not approximately 1.25V suspect U2.
 - b. Measure the +20V UNREG (P1-7). If this voltage is less than approximately +30V, troubleshoot the +20V rectifier (refer to the A19 troubleshooting).
 - c. Examine the +22V supply for burnt or discolored components
 - d. Suspect a shorted capacitor, diode, or crowbar SCR if the procedures above do not isolate the problem.

The +22V Output Voltage is Incorrect (Tolerance is $+22V \pm 1.1V$)

1. Ensure that ac mains voltage is nominal and that the line voltage selector PC board is installed with the proper line voltage selected.
2. Measure the +20V UNREG input with respect to ground. If the voltage is less than approximately +30V, troubleshoot the +20V Rectifier (see the A19 assembly troubleshooting).
3. With an oscilloscope, check the output voltage for oscillations. If the output is approximately 1.25V, C10 is probably shorted.
4. Try readjusting R3 (+22V adjustment)

Table A35-1. A35 Power Supply Destinations

Power Supply	Destination Assemblies/Connectors
-40V UNREG	A53
+5V UNREG	A52, A62J1, A62J31
+22V	A61, A62J1, A62J3

Table A35-2. A19 Capacitor Assembly P1 Pin I/O

Pin	Mnemonic	Levels	Source	Destination
1 13	+20V AC1 +20V AC1	+20 VAC +20 VAC	A62 LUG (2) A62 LUG (2)	*A *A
2 14	+20V AC2 +20V AC2	+20 VAC +20 VAC	A62 LUG (2) A62 LUG (2)	*A *A
3 15	-10V AC1 -10V AC1	-10 VAC -10 VAC	A62 LUG (6) A62 LUG (6)	*B *B
4 16	-10V AC1 -10V AC1	-10 VAC -10 VAC	A62 LUG (6) A62 LUG (6)	*B *B
5 17	-10V AC2 -10V AC2	-10 VAC -10 VAC	A62 LUG (6) A62 LUG (6)	*6 *B
6 18	-10V AC2 -10V AC2	-10 VAC -10 VAC	A62 LUG (6) A62 LUG (6)	*B *B
7 19	-10V RETURN -10V RETURN	+6.4V AT 13.3 GHZ +6.4V AT 13.3 GHZ	XA53P1-2, 20 XA53P1-2, 20	B C B C
8 20	-10V RETURN -10V RETURN	+6.4V AT 13.3 GHZ +6.4V AT 13.3 GHZ	XA53P1-2, 20 XA53P1-2, 20	B C B C
9 21	+20V UNREG +20V UNREG	+31 2V +31 2V	XA35P1-7, 25 XA35P1-7, 25	*A *A
10 22	GND GND	0V 0V	A62 STAR GND A62 STAR GND	*A *A
11 23	-10V UNREG -10V UNREG	-10V -10V	B C B C	XA53P1-27, 28 XA53P1-27, 28
12 24	-10V UNREG -10V UNREG	-10V -10V	B C B C	XA53P1-27, 28 XA53P1-27, 28

A single letter in the source or destination column refers to a function block on this assembly schematic.

An asterisk (*) denotes multiple sources or destinations; refer to the A62 motherboard wiring list for a complete representation of signal sources and destinations.

A35 Rectifier Component-Level Troubleshooting

Table A35-3. A35 Rectifier P1 Pin I/O

Pin	Mnemonic	Levels	Source	Destination
1 19	+5V UNREG +5V UNREG	+7 TO +9V +7 TO +9V	C C	* *
2 20	+5V UNREG +5V UNREG	+7 TO +9V +7 TO +9V	C C	* *
3 21	+5V UNREG +5V UNREG	+7 TO +9V +7 TO +9V	C C	* *
4 22	GND GND	0V 0V	A62 STAR GND A62 STAR GND	*C *C
5 23				
6 24	-40V UNREG -40V UNREG	-40V -40V	A B A B	* *
7 25	+20V UNREG +20V UNREG	+31.2V +31.2V	D D	* *
8 26	+5V AC1 +5V AC1	7V AC 7V AC	A62 LUG (5) A62 LUG (5)	*C *C
9 27	+5V AC1 +5V AC1	7V AC 7V AC	A62 LUG (5) A62 LUG (5)	*C *C
10 28	+5V AC1 +5V AC1	7V AC 7V AC	A62 LUG (5) A62 LUG (5)	*C *C
11 29				
12 30	+5V AC2 +5V AC2	7V AC 7V AC	A62 LUG (5) A62 LUG (5)	*C *C
13 31	+5V AC2 +5V AC2	7V AC 7V AC	A62 LUG (5) A62 LUG (5)	*C *C
14 32	+5V AC2 +5V AC2	7V AC 7V AC	A62 LUG (5) A62 LUG (5)A	*C *C
15 33	-40V AC1 -40V AC1	-40V AC -40V AC	A62 LUG (4) A62 LUG (4)	*A *A
16 34	-40V AC2 -40V AC2	-40V AC -40V AC	A62 LUG (4) A62 LUG (4)	*A *A
17 35				
18 36	+22V +22V	22V 22V	D E D E	* *

A single letter in the source or destination column refers to a function block on this assembly schematic.

An asterisk (*) denotes multiple sources or destinations; refer to the A62 motherboard wiring list for a complete representation of signal sources and destinations.

A35 Rectifier Component-Level Troubleshooting

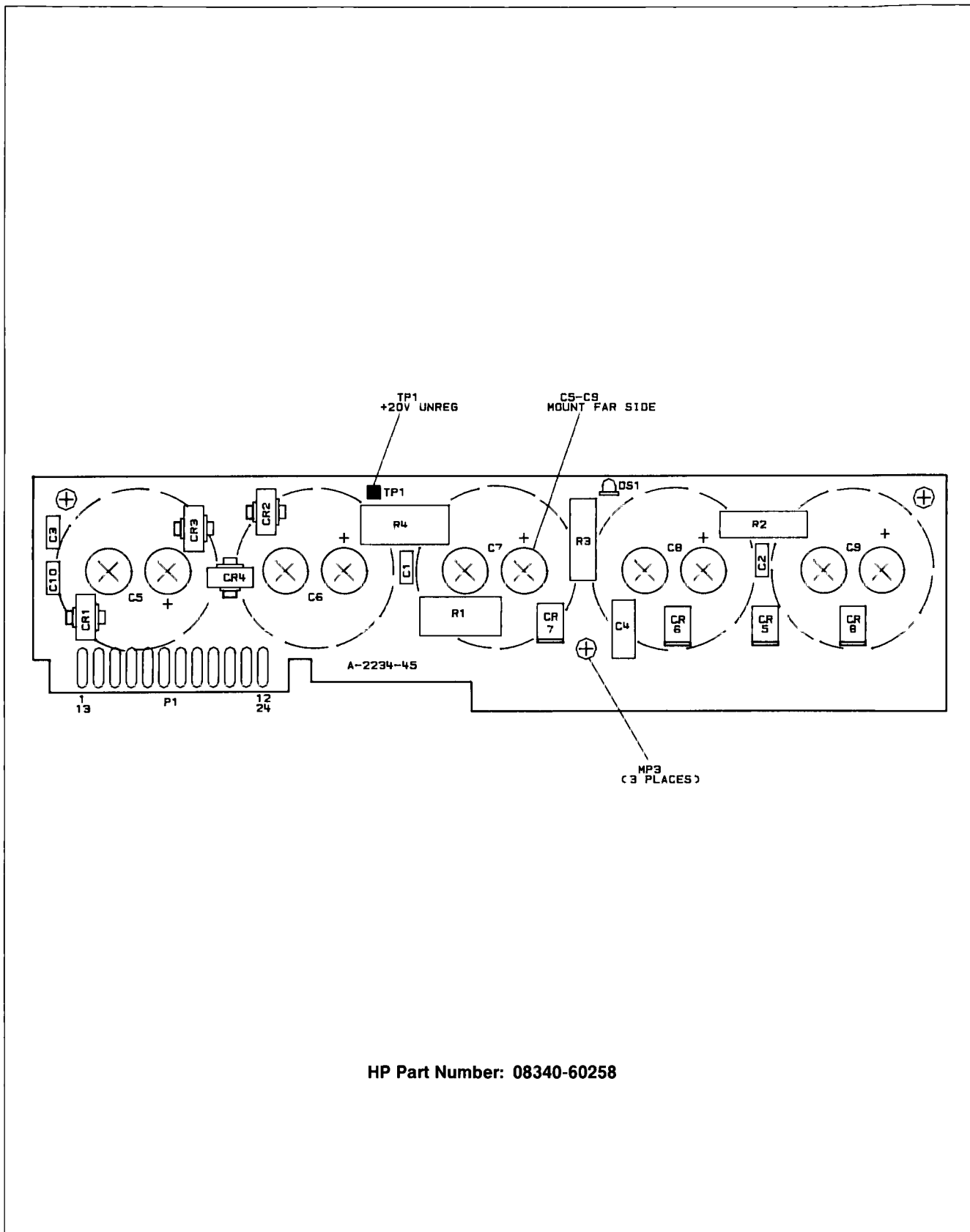

HP Part Number: 08340-60258

Figure A35-1. A19 Capacitor Assembly Component Location Diagram

A35 Rectifier Component-Level Troubleshooting

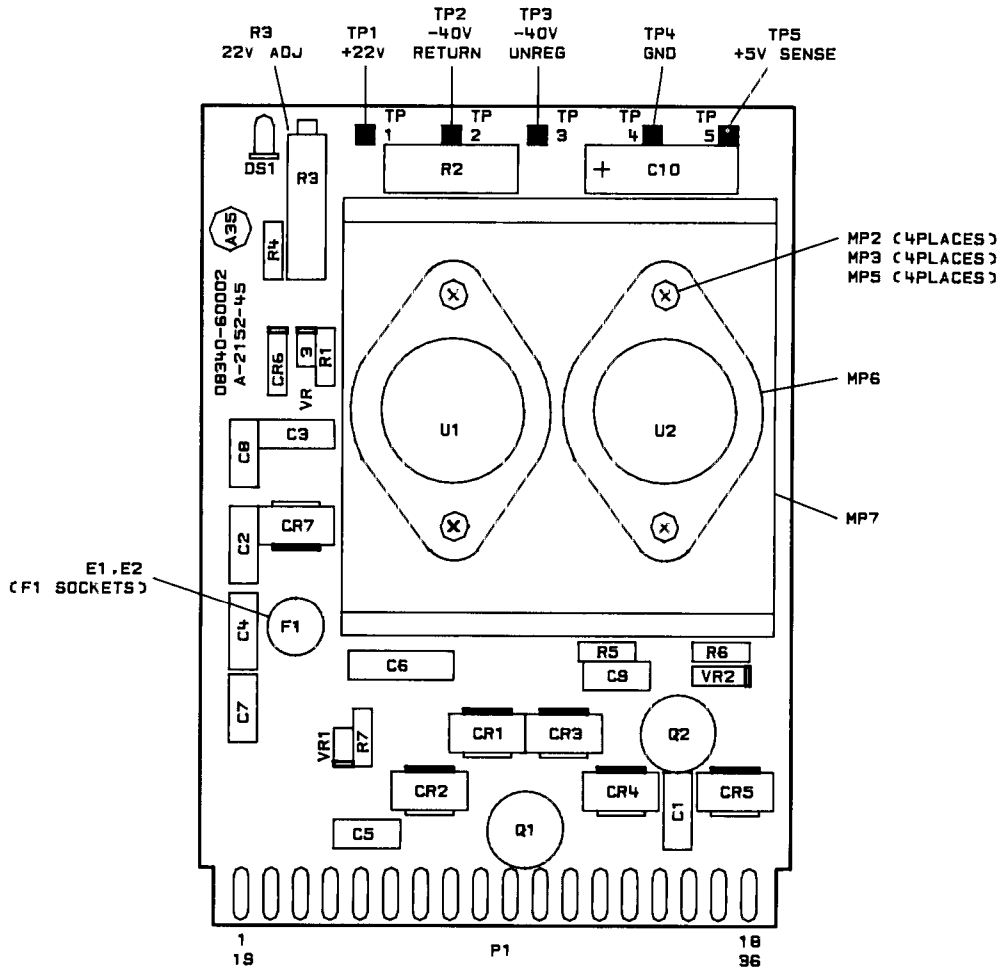

HP Part Number: 08340-60259

Figure A35-2. A35 Rectifier Component Location Diagram

100, 120, 250, 500, 1000, 5000, 10000, 50000, 100000
50-D012

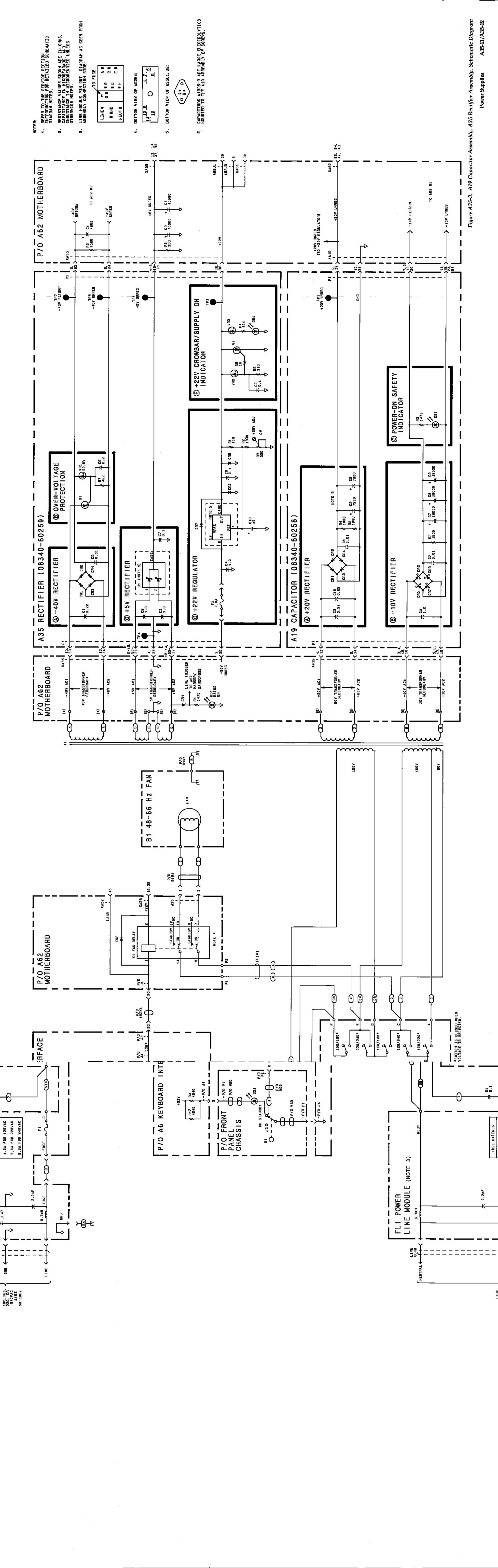

NOTES:

1. REFER TO THE SERVICE SECTION INTRODUCTION FOR DETAILED SCHEMATIC DIAGRAM NOTES.
2. RESISTANCE VALUES SHOWN ARE IN OHMS, CAPACITANCE IN MICROFARADS, AND OTHER VALUES UNLESS OTHERWISE NOTED.
3. LINE MODULE PIN OUT DIAGRAM AS SEEN FROM ASSEMBLY CONNECTION SIDE.
4. BOTTOM VIEW OF A35U1:

LINE 1	A
LINE 2	B
LINE 3	C
LINE 4	D
LINE 5	E
LINE 6	F
LINE 7	G
LINE 8	H
LINE 9	I
LINE 10	J
LINE 11	K
LINE 12	L
5. BOTTOM VIEW OF A35U1 UR:

LINE 1	1
LINE 2	2
LINE 3	3
LINE 4	4
LINE 5	5
LINE 6	6
LINE 7	7
LINE 8	8
LINE 9	9
LINE 10	10
LINE 11	11
LINE 12	12
6. CAPACITORS A35U1-8 ARE LARGE ELECTROLYTICS MOUNTED TO THE A19 ASSEMBLY BY SCREWS.

Figure A35-3. A19 Capacitor Assembly, A35 Rectifier Assembly, Schematic Diagram
 A35-11/A35-12
 Power Supplies

A35 Rectifier Component-Level Troubleshooting

Table A35-4. A19 Capacitor Assembly Replaceable Parts

Reference Designation	HP Part Number	C D	Qty	Description	Mfr Code	Mfr Part Number
A19	08340-60258	9	1	CAPACITOR ASSEMBLY		
A19C1	0160-2055	9	2	CAPACITOR-FXD 01UF +80-20% 100VDC CER	28480	0160-2055
A19C2	0160-2055	9		CAPACITOR-FXD 01UF +80-20% 100VDC CER	28480	0160-2055
A19C3	0160-6143	4	2	CAPACITOR-FXD 22UF ±20% 160VDC CER	28480	0160-6143
A19C4	0160-5647	1	1	CAPACITOR-FXD 1UF ±10% 100VDC CER	28480	0160-5647
A19C5	0180-2603	5	2	CAPACITOR-FXD 7200UF +75-10% 50VDC AL	28480	0180-2603
A19C6	0180-2603	5		CAPACITOR-FXD 7200UF +75-10% 50VDC AL	28480	0180-2603
A19C7	0180-2671	7	3	CAPACITOR-FXD 012F +75-10% 30VDC AL	00853	500123U030AC2A
A19C8	0180-2671	7		CAPACITOR-FXD 012F +75-10% 30VDC AL	00853	500123U030AC2A
A19C9	0180-2671	7		CAPACITOR-FXD 012F +75-10% 30VDC AL	00853	500123U030AC2A
A19C10	0160-6143	4		CAPACITOR-FXD 22UF ±20% 200VDC CER	28480	0160-6143
A19CR1	1901-0662	3	4	DIODE-PWR RECT 100V 6A	04713	MR751
A19CR2	1901-0662	3		DIODE-PWR RECT 100V 6A	04713	MR751
A19CR3	1901-0662	3		DIODE-PWR RECT 100V 6A	04713	MR751
A19CR4	1901-0662	3		DIODE-PWR RECT 100V 6A	04713	MR751
A19CR5	1901-0935	3	4	DIODE-PWR RECT 45V 8A	28480	1901-0935
A19CR6	1901-0935	3		DIODE-PWR RECT 45V 8A	28480	1901-0935
A19CR7	1901-0935	3		DIODE-PWR RECT 45V 8A	28480	1901-0935
A19CR8	1901-0935	3		DIODE-PWR RECT 45V 8A	28480	1901-0935
A19DS1	1990-1146	7	1	LED-LAMP LUM-INT=1MCD IF=20MA-MAX BVR=5V	28480	1990-1146
A19MP1	2190-0011	8	10	WASHER-LK INTL T NO 10 195-IN-ID	28480	2190-0011
A19MP2	2680-0129	8	10	SCREW-MACH 10-32 312-IN-LG PAN-HD-POZI	00000	ORDER BY DESCRIPTION
A19MP3	2360-0113	2	3	SCREW-MACH 6-32 25-IN-LG PAN-HD-POZI	00000	ORDER BY DESCRIPTION
A19MP4	08340-00019	4	1	CAP SHIELD	28480	08340-00019
A19R1	0764-0016	8	2	RESISTOR 1K 5% 2W MO TC=0±200	28480	0764-0016
A19R2	0698-3407	6	1	RESISTOR 1.96K 1% 5W F TC=0±100	28480	0698-3407
A19R3	0757-1078	9	1	RESISTOR 1.47K 1% 5W F TC=0±100	28480	0757-1078
A19R4	0764-0016	8		RESISTOR 1K 5% 2W MO TC=0±200	28480	0764-0016
A19TP1	0360-0535	0	1	TERMINAL TEST POINT PCB	00000	ORDER BY DESCRIPTION

A35 Rectifier Component-Level Troubleshooting

Table A35-5. A35 Rectifier Assembly Replaceable Parts

Reference Designation	HP Part Number	C D	Qty	Description	Mfr Code	Mfr Part Number
A35	08340-60259	0	1	RECTIFIER ASSEMBLY	28480	08340-60259
A35C1	0160-6143	4	1	CAPACITOR-FXD 22UF ±20% 160VDC	28480	0160-6143
A35C2	0160-6499	3	3	CAPACITOR-FXD 1UF ±20% 63VDC MET-POLYE	28480	0160-6499
A35C3	0160-6499	3		CAPACITOR-FXD 1UF ±20% 63VDC MET-POLYE	28480	0160-6499
A35C4	0160-6499	3		CAPACITOR-FXD 1UF ±20% 63VDC MET-POLYE	28480	0160-6499
A35C5	0160-2055	9	2	CAPACITOR-FXD 01UF +80-20% 100VDC CER	28480	0160-2055
A35C6	0160-0128	3	1	CAPACITOR-FXD 2.2UF ±20% 50VDC CER	28480	0160-0128
A35C7	0160-2055	9		CAPACITOR-FXD 01UF +80-20% 100VDC CER	28480	0160-2055
A35C8	0160-3094	8	2	CAPACITOR-FXD 1UF ±10% 100VDC CER	28480	0160-3094
A35C9	0160-3094	8		CAPACITOR-FXD 1UF ±10% 100VDC CER	28480	0160-3094
A35C10	0180-2129	0	1	CAPACITOR-FXD 10UF ±10% 50VDC TA	56289	150D106X9050R2
A35CR1	1901-0662	3	6	DIODE-PWR RECT 100V 6A	04713	MR751
A35CR2	1901-0662	3		DIODE-PWR RECT 100V 6A	04713	MR751
A35CR3	1901-0662	3		DIODE-PWR RECT 100V 6A	04713	MR751
A35CR4	1901-0662	3		DIODE-PWR RECT 100V 6A	04713	MR751
A35CR5	1901-0662	3		DIODE-PWR RECT 100V 6A	04713	MR751
A35CR6	1901-0028	5	1	DIODE-PWR RECT 400V 750MA DO-29	28480	1901-0028
A35CR7	1901-0662	3		DIODE-PWR RECT 100V 6A	04713	MR751
A35DS1	1990-1148	9	1	LED-LAMP LUM-INT=1MCD IF=20MA-MAX BVR=5V	28480	1990-1148
A35F1	2110-0425	0	1	FUSE 2A 125V 25X 27	28480	2110-0425
A35MP1				NOT ASSIGNED		
A35MP2	0340-0994	3	2	TRANSISTOR INS-TO-3	28480	0340-0994
A35MP3	0590-0526	6	1	THREADED INSERT-NUT 4-40 065-IN-LG SST	28480	0590-0526
A35MP4	1200-0081	4	1	INSULATOR-FLG-B5HG NYLON	28480	1200-0081
A35MP5	2200-0107	6	4	SCREW-MACH 4-40 375-IN-LG PAN-HD-POZI	00000	ORDER BY DESCRIPTION
A35MP6	6040-0454	0		THERMAL COMPOUND SYNTH	28480	6040-0454
A35MP7	08340-00009	2	1	HEAT SINK RECTIFIER	28480	08340-00009
A35P1	1251-2313	6	2	CONNECTOR-SGL CONT SKT 04-IN-BSC-SZ RND	28480	1251-2313
A35P2	1251-2313	6		CONNECTOR-SGL CONT SKT 04-IN-BSC-SZ RND	28480	1251-2313
A35Q1	1884-0018	5	2	THYRISTOR-SCR 2N4186 VRRM=200	04713	2N4186
A35Q2	1884-0018	5		THYRISTOR-SCR 2N4186 VRRM=200	04713	2N4186
A35R1	0757-0401	0	1	RESISTOR 100 1% 125W F TC=0±100	24546	C4-1/8-T0-101-F
A35R2	0698-3406	5	1	RESISTOR 1 33K 1% 5W F TC=0±100	28480	0698-3406
A35R3	2100-3123	0	1	RESISTOR-TRMR 500 10% C SIDE-ADJ 17-TRN	02111	43P501
A35R4	0698-0082	7	1	RESISTOR 464 1% 125W F TC=0±100	24546	C4-1/8-T0-4640-F
A35R5	0757-0346	2	1	RESISTOR 10 1% 125W F TC=0±100	24546	C4-1/8-T0-10R0-F
A35R6	0698-3444	1	1	RESISTOR 316 1% 125W F TC=0±100	24546	C4-1/8-T0-316R-F
A35R7	0698-3447	4	1	RESISTOR 422 1% 125W F TC=0±100	24546	C4-1/8-T0-422R-F
A35TP1-5	0360-0535	0	5	TERMINAL TEST POINT PCB	00000	ORDER BY DESCRIPTION
A35U1	1905-0239	0	1	DIODE-CT-RECT 45V 30A	01281	SD-241
A35U2	1826-0423	4	1	IC V RGLTR TO-3	27014	LM317K
A35VR1	1902-0197	1	1	DIODE-ZNR 82V 5% PD=1W IR=5UA	28480	1902-0197
A35VR2	1902-1249	6	1	DIODE-ZNR 24 9V 5% DO-15 PD=1W TC=+ 081%	28480	1902-1249
A35VR3	1902-0202	9	1	DIODE-ZNR 15V 5% PD=1W IR=5UA	28480	1902-0202

A52 Positive Regulator Circuit Description

ASSEMBLY PURPOSE

The A52 positive regulator contains circuitry for the:

- +20V supply
- +12V supply
- +5.2V supply
- Voltage accuracy sensing circuitry
- ON/STANDBY and SHUTDOWN functions

The +20V supply is a self-starting regulator, with a precision reference to accurately set the output voltage. With the exception of the independent +22V standby supply (see the A35 assembly), all supplies are dependent on the +20V output.

NOTE: The +20 and +5.2V supplies are critical, low noise supplies with a specified periodic and random deviation (PARD) less than 100 μ V peak. The +12V supply is non-critical, with a specified PARD less than 5 mV peak.

+10V/+4.9V REFERENCE (BLOCK A)

A zener regulator creates a stable +10V reference (+10 VR) for use in the +20V regulator (block B), the standby/overtemperature shutdown (block E), and the voltage sense circuitry (block L).

Bias for the zener regulator is supplied by +20V UNREG. If +10VR is incorrect, check for excessive supply loading. There is a problem if the value of +10V REF changes significantly as you cycle the line switch.

The +4.9V reference (+4.9VR) is generated by a divider network, and is used for the comparators in standby/overtemperature shutdown (block E), and in the voltage sense circuits (block L).

+20V REGULATOR (BLOCK B)

The +20V regulator is the master regulator for the instrument power supply system. Except for the +22V standby supply (which is on continuously), all instrument supplies are dependent on the +20V supply.

The +20V startup current source, driven from the internal +10V reference (block A), forms a 6 ma (nominal) current sink.

In standby, the output of block E (LSOS) is low, and the current from Q14 is shorted to ground. When the instrument is on, the current from Q14 goes to the base of the motherboard darlington pass transistor, causing the +20V output to increase.

The DC Feedback Loop (Error Correction Circuit)

When the +20V output exceeds +10V, the error correction circuitry begins to function. TP2 provides both a check of the reference voltage source, and a +10.00V reference for instrument troubleshooting.

The DC feedback loop (error correction circuit) receives the +20V through a voltage divider and compares it to the output of the voltage source. The output of the error amplifier goes to the base of the motherboard darlington transistor, completing the loop. The error amplifier acts as negative feedback to regulate the output voltage.

Noise Filtering

A noise filter cleans up broadband noise on the integrated reference voltage source, and slows down the startup transient.

Foldback Current Limiting

Foldback resistors form the current sense resistor for the foldback current limit circuit. As the current from the motherboard transistor exceeds 2.4A, the voltage at the emitter of Q8 decreases, turning this transistor on. This allows current to flow through the transistor, sinking base current from the motherboard transistor, reducing its current output.

Foldback current limit:

- Reduces the supply output current capability as its output voltage drops (as when driving a short).
- Makes power dissipation less with the supply shorted, than when the supply is in normal operation (see Table A52-1).

Table A52-1. Power Supply Output Current Capability

Supply	Maximum Out	Short Circuit Current
+20	2.4A	< 5A
+12	1.8A	No Foldback (>2A)
+5	10A	<3A
-5	1.8A	No Foldback (>2A)
-10	6.0A	<3A
-15	1.8A	No Foldback (>2A)
-40	1.7A	<.5A

+20V CROWBAR/SUPPLY ON INDICATOR (BLOCK C)

This block monitors the +20V regulator output. If the voltage exceeds approximately 23V, the supply is shorted to ground, protecting instrument loads. The yellow LED near shows the +20V supply status. The +20V supply tolerance is $\pm 5\%$, or 1.0V.

REFERENCE OSCILLATOR SUPPLY (BLOCK D)

When HSTD (high internal 10 MHz standard enable) is set high by the microprocessor, this block provides the +20V reference oscillator supply to the A51 10 MHz reference oscillator.

STANDBY/OVERTEMP SHUTDOWN (BLOCK E)

In STANDBY, LSBY (low standby) is pulled low by the front panel ON/STANDBY switch, driving the output of this block low, which pulls the base of the motherboard darlington transistor to ground. This shuts down the +20V supply, along with all other supplies that are dependent on it.

When the ON/STANDBY switch is in the ON position, LSBY rises to +22V. The output of this block goes high, releasing the base of the motherboard darlington transistor. The +20V supply starts, and the CLK input to the flip-flop goes high. This transition clocks a zero into the flip-flop, resetting any overtemperature condition that may have occurred. During initial power-up, the flip-flop is reset to ensure that the instrument is always operational (the overtemp flag is cleared) when turned on.

The Heat Sink Sensor

The main heat sink temperature sensor is a normally open bi-metallic switch that closes when the heat sink reaches 100° C. The sensor is tied from LHSOT (low heat sink overtemperature sensor) to ground. When the switch closes, LHSOT is pulled low, forcing the output of the input comparator high. This sets the flip-flop output high, forcing the output of the output comparator high, which turns on the red overtemp LED. When this happens, LSOS goes low, shutting all instrument power supplies down except the +22V supply. The only way to clear the overtemperature condition is to turn the instrument to standby, and then back on.

GROUNDINGS AND COMMONS (BLOCK F)

To isolate power ground currents from sensitive circuitry in the regulators, power ground (plain ground) sense ground (ground 1), and +20V ground (ground 2) are separated at the edge connector fingers. The +5.2V sense ground (ground 3) is taken from +5.2V sense (-).

+5.2V REGULATOR (BLOCK G)

+20V provides the reference voltage, and powers the loop error correction amplifiers. The +5.2V output is sensed on the A62 motherboard at the main 5V power distribution point. The +5.2V sense (+) comes back to this assembly, through a voltage divider, and is compared to the generated reference by an error amplifier. The error amplifier output voltage regulates the motherboard and pass transistor through two current driver devices. The +5.2V sense (-), from the central ground distribution point (STAR ground) on the motherboard, provides ground reference (ground 3).

Foldback current limit operates in the same way as in the +20V supply.

+5.2V CROWBAR/PROTECTION (BLOCK H)

When +5.2V out exceeds approximately 6.2V, the zener conducts, biasing the crowbar SCR on and shorting the +5.2V output to ground. This protects load circuits from an overvoltage condition. A yellow LED shows the status of the +5.2V supply. The +5.2V supply tolerance is $\pm 5\%$ (0.26V).

MICROPROCESSOR PROTECTION (BLOCK I)

If the $-5.2V$ supply is more positive than $-4.5V$, the protection transistor turns on, shorting the adjustment terminal of the +12V regulator (block E) to ground, pulling the +12V output to +1.3V. This protects the microprocessor from excessive power dissipation.

If you make any repairs to the +12V or $-5V$ supplies, check the operation of this circuit **before** you turn the instrument on.

+12V REGULATOR (BLOCK J)

The +12V regulator is an adjustable three-terminal device, whose output voltage is adjusted with feedback resistors. A factory selected resistor compensates for variations in regulator characteristics (increasing the value increases the +12V output).

The input capacitor provides regulator stability. A noise filter increases the regulator ripple rejection and lowers its output impedance. A protection diode protects the regulator from damage due to charge stored on the reference capacitor if there is a short from the +12V output to ground. An output diode protects the +12V power supply loads from reverse polarity power if there is a short between +12V and a negative power supply.

+12V CROWBAR/POWER ON INDICATOR (BLOCK K)

When +12V out exceeds approximately 13.5V, the supply output is shorted to ground. This protects load circuits from the overvoltage. A yellow LED shows the +12V power supply status, and begins to light when the output of A62U1 is approximately +7.6V. The +12V supply tolerance is $\pm 5\%$ (0.6V).

VOLTAGE SENSE (BLOCK L)

When the +5.2V, +12V, or the +20V supply goes out of regulation, its comparator output goes low, shorting a delay capacitor to ground. This forces HPUP (high power up) low, pulling LIPS (low instrument preset) low.

HNUP (high negative up) is connected to the A53 negative regulator assembly, and the A56 $-15V$ supply assembly. This line is pulled low if any of these supplies go out of regulation.

Approximately 300 mS after all supplies come into regulation, HPUP and LIPS go high. These signals are used by the microprocessor (and several other circuits) to control instrument activity and to ensure proper initialization.

A52 Positive Regulator Component-Level Troubleshooting

WARNING

When the instrument is connected to ac line power and/or the A19 power-on safety indicator LED is on, there are voltages at points inside the instrument that can cause injury or death. Any servicing of this instrument with protective covers removed should be done only by trained personnel who are aware of the hazards involved.

CAUTION

The crowbar circuitry on this assembly protects the instrument, do not operate the supply without it.

To avoid non-repairable damage to assemblies, do not reinstall the A19, A35, A52, or A53 assemblies unless ac mains is disconnected from the instrument.

This assembly contains static sensitive components. Troubleshoot this assembly only at a work station equipped with an anti-static surface, and use a grounding strap that provides a path to ground of between 1 M Ω and 2.5 M Ω . Always handle printed circuit boards by the edges; never touch the finger contacts.

The thermal connection between the voltage regulator U2, the full wave rectifier U1, and the A35 heat sink is the dominant factor in the two devices' long term reliability. When installing or replacing either of these parts. Use only oil based thermal compound (HP Part Number 6040-0454 CD0).

DO NOT use silicone based thermal compound. Silicone based oil migrates past element sockets, switch contacts, or printed circuit board edge connectors, raising contact resistance, or electrically isolating the contacts. Silicone based thermal compounds disperse into the air, depositing themselves anywhere in the instrument. Heat increases the rate of dispersion.

HOW TO APPLY THERMAL COMPOUND

When installing or replacing a pass transistor or voltage regulator, apply thermal compound as follows:

1. Apply a thin coating of thermal compound (HP Part Number 6040-0454 CD0) to both sides of the insulating washer. The coating should provide a thin but continuous layer of compound from component-to-washer and washer-to-heatsink. An excessive amount of compound reduces its ability to transfer heat.

2. Tighten the pass element mounting screws with seven inch-pounds of force. Tightening with less force diminishes the heat transfer capability of the thermal compound. Tightening with greater force can damage the mounting hardware.

IF ALL SUPPLIES ARE DOWN

- 1 Check the +20V regulator in block B (+20V \pm 5%).

If this supply is down, the rest of the instrument supplies (except the +22V supply) will be down.

NOTE: If more than one supply has failed, and the +20V supply is not one of them, refer to section I, POWER SUPPLIES, in the *HP 8340B/8341B Assembly-Level Service Manual*.

HOW TO DETERMINE SUPPLY/LOAD FAILURE

- 1 Unplug the instrument from ac line power
2. After the power-on safety indicator goes out, remove the A52 assembly and place it on an extender board.
3. Before installing the extender board in the instrument, apply thin, nonconductive tape to the extender board +20V output fingers (use colored tape, if possible, to make it highly visible, so you remember to remove it when you are through troubleshooting). **Do not** apply tape to the A52 printed circuit board fingers.
4. Reinstall the A52 assembly and plug the instrument in to ac line power. If the power supply now operates properly, suspect a short on an instrument assembly that uses +20V.
5. Remove the tape from the extender board fingers and clean the fingers using the following procedure



NEVER clean PC board fingers with an eraser. **NEVER** use tap water in the cleaning solution. Chloride contamination from tap water, from salt (skin contact), or from any other source, can cause reliability problems. Always wear a ground strap when handling any internal component or assembly.

How to Clean Printed Circuit Board Fingers

1. Mix one part de-ionized (or de-chlorinated) water with two parts isopropyl alcohol.
2. Apply this solution to a clean, lint free, cloth (HP Part Number 9310-0039 CD3).
3. Rub the PC board fingers carefully, then dry them with a clean part of the cloth

+20V LOAD FAILURE

1. One at a time, remove each assembly that uses +20V.
2. Remove any cables that carry the affected supply (refer to table A52-2).

+20V POWER SUPPLY FAILURE

If the power supply output does not return to normal after you tape off the extender board +20V fingers, refer to the following:

The +20V Output Voltage is Approximately 0.8 to 1.0V

1. Crowbar Circuit Verification

If the output voltage is approximately 0.8 to 1.0V the crowbar circuit is engaged.

- a. Connect the instrument to a auto-transformer set for 0V output.
- b. While monitoring the supply output voltage, slowly increase the auto-transformer output voltage. If the crowbar fires before the supply output reaches +20V suspect VR1

2. Regulator Verification

- a. If the power supply output reaches +20V, stop increasing auto-transformer voltage.
- b. Check for +10V at the base of Q12. If Q12, Q13, and Q14 are operating correctly, check the precision +10V reference, U2, and the operational amplifier, U1.
- c. Measure the voltage across R7. If the voltage is not 0.6V (6 mA through Q14), check for 0.6V across R6 (6 mA through Q13).
- d. Measure the emitter voltage of Q12. The current through Q12 should also be approximately 6 mA $[(+10 \text{ VR} - 0.7\text{V}) \div 1620 = 5.7 \text{ mA}]$.
- e. Check the voltage across CR7 (block E). If the voltage is 0.6V, the base current of A62Q3 is being drawn away by U4D.
- f. If the voltage across CR7 is 0.6V, check the input pins of U4D (block E). Pin 11 should be approximately +20V, and pin 10 should be +4.9V. If they are, suspect U4. A failure of U4C (block E) can draw A62Q3 base current, but you can verify this only by changing U4 or lifting CR7.
- g. Measure the voltage across the base and emitter of A62Q3 (P1-7 and 8). If the voltage is not approximately 1.25V, suspect A62Q3. Measure the voltage between A62Q3 collector and emitter. If there is little or no voltage the transistor is probably shorted.

The +20V Output Voltage is Approximately 0V

- 1 Initial Checks
 - a. Ensure that ac mains voltage is nominal, and that the line voltage selector cam is installed properly in the line filter module, FL1.
 - b. Ensure that the proper fuse value is installed.
 - c. If the line voltage and fuse are correct, and the power supply input fuse (F1) is blown, suspect A62Q3.
2. Regulator Verification
 - a. Measure the +20V UNREG (P1-23). If this voltage is less than approximately +30V, troubleshoot the +20V rectifier (see A19 troubleshooting).
 - b. Measure across the base and emitter of A62Q3 (P1-7 and 32). If the voltage is not approximately 1.25V suspect A62Q3.
3. Current Limit Checks
 - a. Check for 0.6V across the emitter/base junction of Q8, indicating that the current foldback circuit is engaged and is shutting down A62Q3.
 - b. Measure Q8 emitter to collector. If the voltage is approximately 0.2V or less, Q8 may be shorted.
 - c. Examine the +20V supply for burnt or discolored components.
 - d. Suspect a shorted capacitor, diode, or crowbar SCR if the procedures above do not isolate the problem.

The +20V Output Voltage is Incorrect (Tolerance is +20V \pm 1.1V)

1. Ensure that ac mains voltage is nominal and that the line voltage selector cam is installed with the proper line voltage selected
2. Measure the +20V UNREG input with respect to ground. If the voltage is less than approximately +30V, troubleshoot the +20V Rectifier (see the A19 troubleshooting).
3. With an oscilloscope, check the output voltage for oscillations. If the supply is oscillating, check the precision 10V reference for oscillations. Check loop frequency compensation capacitors C1, C2, C4, and C5.
4. Check the voltage out of U2, and the values of divider resistors R13 and R15. Make sure the feedback path to U1 is not open.
5. Check C4 and C5 by removing them from the circuit. C4 and C5 can cause supply noise or temperature instability if they leak. The voltage at U1 pin 2 must be 1/2 of the supply output voltage

+12V REGULATOR

Supply tolerance = $+12V \pm 5\%$ (0.6V)

If the +12V regulator is down, remember that this supply comes up only when the +5.2V and -5.2V supplies both operate properly. If the A53 negative regulator assembly is not installed, the +12V supply does not function.

1. Measure the base of Q3 in block I.
 - If it is on (0.6V or greater), VR4 is open, or the -5.2V supply is down
 - If it is off, U6B pin 1 in block L is causing the problem if the +12V U1 ADJ line is low.
2. Use the **SUPPLY/LOAD FAILURE DETERMINATION** procedure to determine if the +12V supply has failed or is being forced into current limit by a short elsewhere in the instrument.
3. If the problem is load related, troubleshoot similar to the +20V load failure section. If the +12V supply is at fault, proceed as follows:

+12V POWER SUPPLY FAILURE

If the power supply output does not return to normal after you tape off the extender board +12V fingers, refer to the appropriate troubleshooting below:

NOTE: After you repair the +12V supply, make sure the output is $+12.0V \pm 0.6V$. Change factory select resistor R29 if necessary. Increase R29 to increase the +12V output

The +12V Output Voltage is Approximately 0.8 to 1.0V

1. Crowbar Circuit Verification
 - If the output voltage is approximately 0.8 to 1.0V the crowbar circuit is engaged.
 - a. Connect the instrument to a auto-transformer set for 0V output.
 - b. While monitoring the supply output voltage, slowly increase the auto-transformer output voltage. If the crowbar fires before the supply output reaches +12V suspect VR2.
2. Regulator Verification
 - a. If the power supply output reaches +12V, stop increasing auto-transformer voltage.
 - b. Measure the voltage across pin 1 and the case of A62U1 (regulator) If the voltage is not approximately 1.25, suspect A62U1.
 - c. Measure the voltage from the input to the output of A62U1. If there is little or no voltage, A62U1 is probably shorted.

The +12V Output Voltage is Approximately 0V

1. Initial Checks
 - a. Ensure that ac mains voltage is nominal, and that the line voltage selector cam is installed properly in the line filter module, FL1.
 - b. Ensure that the proper fuse value is installed.
 - c. If the line voltage and fuse are correct, and the power supply input fuse (F1) is blown, suspect A62U1
2. Regulator Verification
 - a. Measure across pin 1 and the case of A62U1. If the voltage is not approximately 1.25V suspect A62U1.
 - b. Measure the +20V regulator output (TP4). If this voltage is incorrect, troubleshoot the +20V power supply.
 - c. Examine the +12V supply for burnt or discolored components
 - d. Suspect a shorted capacitor, diode, or crowbar SCR if the procedures above do not isolate the problem.

The +12V Output Voltage is Incorrect (Tolerance is +12V \pm 0.6V)

1. Ensure that ac line voltage is nominal and that the line voltage selector cam is installed with the proper line voltage selected.
2. Measure the +20V regulator output (TP4). If this voltage is incorrect, troubleshoot the +20V power supply.
3. With an oscilloscope, check the output voltage for oscillations.
4. If the output voltage is approximately 1.25V, either A62C6 or A62C7 is probably shorted, or Q3 or U6B are on.

REFERENCE OSCILLATOR SUPPLY

1. If the +20V switched supply does not come up, or will not shut down, check driver Q4, and pass element Q5 in block D.
2. Ensure that HSTD (internal 10 MHz standard enable) is getting to the assembly properly.

+5.2V REGULATOR

Supply tolerance = +5.2V \pm 5% (0.26V).

Because the +5.2V supply and the +20V supply are similar, refer to the +20V supply section to determine if the failure is caused by a supply failure or by a shorted assembly elsewhere in the instrument. If the supply has failed, proceed as follows:

+5.2V POWER SUPPLY FAILURE

The +5.2V Output Voltage is Approximately 0.8 to 1.0V

1. Crowbar Circuit Verification

If the output voltage is approximately 0.8 to 1.0V the crowbar circuit is engaged.

- a. Connect the instrument to a auto-transformer set for 0V output.
- b. While monitoring the supply output voltage, slowly increase the auto-transformer output voltage. If the crowbar fires before the supply output reaches +5.2V suspect VR3.

2. Regulator Verification

- a. If the power supply output reaches +5.2V, stop increasing auto-transformer voltage.
- b. Check the emitter-base voltage of Q7, Q10, and A62Q4. It should be approximately 0.6V. Check for emitter-collector shorts.
- c. Measure the collector-emitter voltage of A62Q4. If there is little or no voltage, A62Q4 is probably shorted.

The +5.2V Output Voltage is Approximately 0V

1. Initial Checks

- a. Ensure that ac line voltage is nominal, and that the line voltage selector cam is installed properly in the line filter module, FL1.
- b. Ensure that the proper fuse value is installed.
- c. If the line voltage and fuse are correct, and the power supply input fuse (F3) is blown, suspect A62Q4.

2. Regulator Verification

- a. Measure the +5V UNREG (P1-13). If this voltage is less than approximately +9.5V, troubleshoot the +5V regulator (see A35 troubleshooting).
- b. Measure the base-emitter voltage of Q7, Q10, and A62Q4. It should be approximately 0.6V.

3. Current Limit Checks

- a. Check for 0.6V across the emitter-base of Q6. This indicates that the current foldback circuit is engaged and that it is shutting down A62Q4.
- b. Measure Q6 emitter-collector. If the voltage is approximately 0.2V or less, Q6 may be shorted.
- c. Examine the +12V supply for burnt or discolored components.
- d. Suspect a shorted capacitor, diode, or crowbar SCR if the procedures above do not isolate the problem.

The +5.2V Output Voltage is Incorrect (Tolerance is +5.2V ±0.26V)

1. Ensure that ac mains voltage is nominal and that the line voltage selector PC board is installed with the proper line voltage selected
2. Measure the +5V UNREG. If this voltage is less than approximately +9.5V, troubleshoot the +5V rectifier (see A35 troubleshooting).
3. With an oscilloscope, check the output voltage for oscillations. Check frequency compensation capacitors C12, C13, and C16.
4. Check the value of divider resistors R67 and R68.
5. Make sure the feedback path to U3 is not open.
6. Check C13 and C14 by removing them from the circuit. They are likely to cause supply noise or temperature instability if they leak.

Table A52-2. A52 Power Supply Destination Chart

Power Supply	Destination Assemblies/Connectors
+20V	A21 through A28, A34, A36, A38, A40 through A43, A53 through A55, A57 through A61
+5.2V	A21 through A28, A34, A36, A37, A39 through A43, A54, A55, A57 through A60, A62J2, A62J19
+12V	A23, A57 through A61, A62J1

Table A52-3. A52 Positive Regulator Supply Limits

Power Supply	A52 TP	Ground	Limits
+20V	4	P1-19	+19.00 – +21.00V
+12V	5	P1-19	+11.4 – +12.6V
+5.2V	P1-17	P1-19	+4.94 – +5.46V

A52 Positive Regulator Component-Level Troubleshooting

Table A52-4. A52 Positive Regulator P1 Pin I/O

Pin	Mnemonic	Levels	Source	Destination
1 25	Q4C Q4C		A62Q4-COLLECTOR A62Q4-COLLECTOR	G G
2 26	Q4C Q4C		A62Q4-COLLECTOR A62Q4-COLLECTOR	G G
3 27	Q4B Q4B		A62Q4-BASE A62Q4-BASE	G G
4 28	Q4E Q4E		A62Q4-EMITTER A62Q4-EMITTER	G G
5 29	Q4E Q4E		A62Q4-EMITTER A62Q4-EMITTER	G G
6 30	Q3C Q3C		A62Q3-COLLECTOR A62Q3-COLLECTOR	A B E A B E
7 31	Q3B		A62Q3-BASE	B B
8 32	Q3E Q3E		A62Q3-EMITTER A62Q3-EMITTER	B B
9 33	+12V +12V	+12V +12V	J K J K	*L *L
10 34	+12V UI ADJ	+10.5V	J	*I L
11 35	+12V UNREG +12V UNREG	+20V +20V	J J	*J *J
12 36	LHSOT LIPS	TTL (LOW TRUE) TTL (LOW TRUE)	A62J31-30 *L	E *
13 37	+5V UNREG +5V UNREG	+7 TO +9V +7 TO +9V	XA35P1-1-3, 19-21 XA35P1-1-3, 19-21	*G *G
14 38	+5V UNREG +5V UNREG	+7 TO +9V +7 TO +9V	XA35P1-1-3, 19-21 XA35P1-1-3, 19-21	*G *G
15 39	+5V SENSE (+) +5V SENSE (-)	+5.2V 0V	G F	L F
16 40	+20V +20V	+20V +20V	B C B C	*D J L *D J L
17 41	+5.2V +5.2V	+5.2V +5.2V	G H G H	* *
18 42	+5.2V +5.2V	+5.2V +5.2V	G H G H	* *
19 43	GND GND	0V 0V	A62 STAR GND A62 STAR GND	*F *F
20 44	+20V REF OSC HNUP	0V/+20V TTL (HIGH TRUE)	D XA53P1-17; XA56P1-1, 16	A62J3-1 *I
21 45	HSTD LSBY	TTL (HIGH TRUE) 0V TO +22V	XA59P1-66 A62J1-20	D E
22 46	-5.2V HPUP	-5.2V TTL (HIGH TRUE)	XA53P1-7, 25 L	*A *
23 47	+20V UNREG +20V UNREG	+31.2V +31.2V	XA35P1-7, 25 XA35P1-7, 25	*A *A
24 48	+20V UNREG +20V UNREG	+31.2V +31.2V	XA35P1-7, 25 XA35P1-7, 25	*A *A

A single letter in the source or destination column refers to a function block on this assembly schematic.

An asterisk (*) denotes multiple sources or destinations, refer to the A62 motherboard wiring list for a complete representation of signal sources and destinations.

A52 Positive Regulator Component-Level Troubleshooting

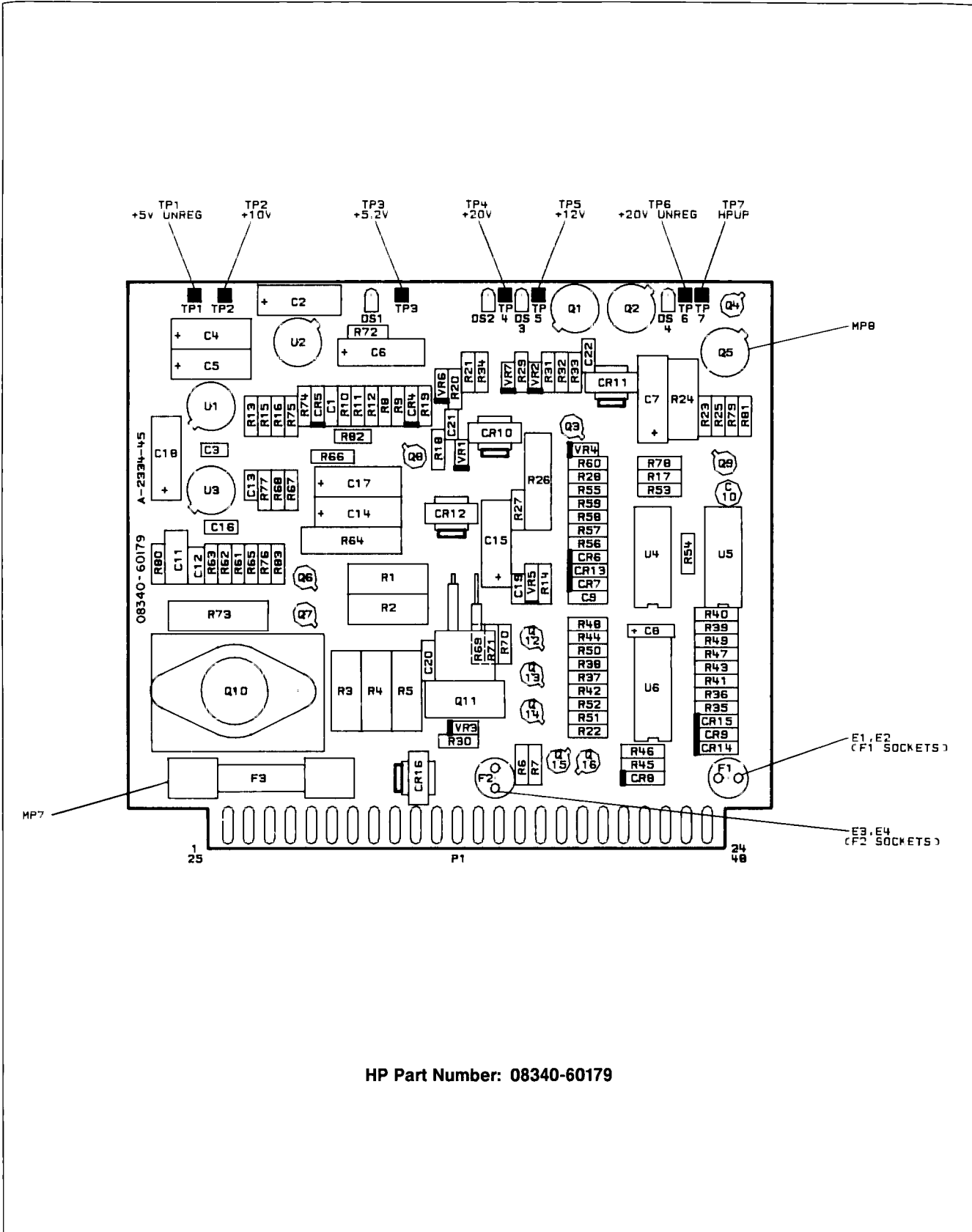

HP Part Number: 08340-60179

Figure A52-1. A52 Positive Regulator Component Location Diagram

AS2 POSITIVE REGULATOR
09340-6079

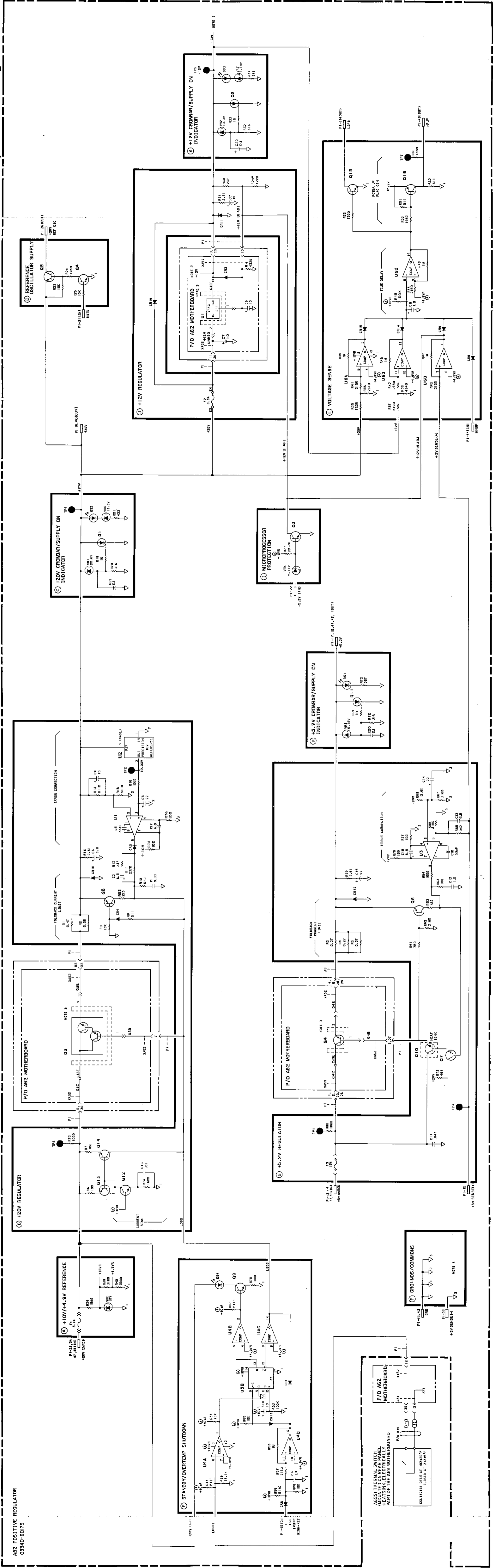

- NOTES:
- RESISTANCE VALUES SHOWN IN OHMS, CAPACITANCE IN MICROFARADS, INDUCTANCE IN MILLIHENRIES UNLESS OTHERWISE NOTED.
 - +12V IS DISTRIBUTED TO THE 03408 THROUGH XAS2 PINS 1 AND 33 THROUGH XAS2 PINS 1 AND 33 IN BLOCK 02 MOTHERBOARD ASSEMBLY IN BLOCK 02.
 - U1, Q3 AND Q4 ARE MOUNTED ON THE MOTHERBOARD THROUGH THE REAR PANEL HEAT SINK.
 - THIS TRACE CONNECTS DIRECTLY TO THE INSTRUMENT STAN GROUND.

Figure A52-2. A52 Positive Regulator, Schematic Diagram
Power Supplies A52-15/A52-16

A52 Positive Regulator Component-Level Troubleshooting

Table A52-5. A52 Positive Regulator Replaceable Parts

Reference Designation	HP Part Number	C D	Qty	Description	Mfr Code	Mfr Part Number
A52	08340-60179	3	1	POSITIVE REGULATOR ASSEMBLY	28480	08340-60179
A52C1	0160-5338	7	1	CAPACITOR-FXD 33UF ±10% 50VDC CER	28480	0160-5338
A52C2	0180-0116	1	4	CAPACITOR-FXD 6 8UF ±10% 35VDC TA	56289	150D685X9035B2
A52C3	0160-4807	3	1	CAPACITOR-FXD 33PF ±5% 100VDC CER 0±30	28480	0160-4807
A52C4	0180-1746	5	2	CAPACITOR-FXD 15UF ±10% 20VDC TA	56289	150D156X9020B2
A52C5	0180-0228	6	3	CAPACITOR-FXD 22UF ±10% 15VDC TA	56289	150D226X9015B2
A52C6	0180-0116	1		CAPACITOR-FXD 6 8UF ±10% 35VDC TA	56289	150D685X9035B2
A52C7	0180-1746	5		CAPACITOR-FXD 15UF ±10% 20VDC TA	56289	150D156X9020B2
A52C8	0160-4005	3		CAPACITOR-FXD 1UF ±20% 100VDC CER	28480	0160-4005
A52C9	0160-4835	7	1	CAPACITOR-FXD 1UF ±10% 50VDC CER	28480	0160-4835
A52C10	0180-2811	7		CAPACITOR-FXD 10UF ±20% 35VDC TA	28480	0180-2811
A52C11	0160-4834	6	1	CAPACITOR-FXD 047UF ±10% 100VDC CER	28480	0160-4834
A52C12	0160-4005	3	1	CAPACITOR-FXD 1UF ±20% 100VDC CER	28480	0160-4005
A52C13	0180-2617	1	1	CAPACITOR-FXD 6 8UF ±10% 35VDC TA	28480	0180-2617
A52C14	0180-0228	6		CAPACITOR-FXD 22UF ±10% 15VDC TA	56289	150D226X9015B2
A52C15	0180-0228	6		CAPACITOR-FXD 22UF ±10% 15VDC TA	56289	150D226X9015B2
A52C16	0160-4386	3	1	CAPACITOR-FXD 33PF ±5% 200VDC CER 0±30	28480	0160-4386
A52C17	0180-0116	1		CAPACITOR-FXD 6 8UF ±10% 35VDC TA	56289	150D685X9035B2
A52C18	0180-0116	1		CAPACITOR-FXD 6 8UF ±10% 35VDC TA	56289	150D685X9035B2
A52C19	0160-4832	4	1	CAPACITOR-FXD 01UF ±10% 100VDC CER	28480	0160-4832
A52C20-22	0160-4084	8	3	CAPACITOR-FXD 1UF ±20% 50VDC CER	28480	0160-4084
A52CR1-3				NOT ASSIGNED		
A52CR4	1901-0033	2	9	DIODE-GEN PRP 180V 200MA DO-7	28480	1901-0033
A52CR5	1901-0033	2		DIODE-GEN PRP 180V 200MA DO-7	28480	1901-0033
A52CR6	1901-0033	2		DIODE-GEN PRP 180V 200MA DO-7	28480	1901-0033
A52CR7	1901-0033	2		DIODE-GEN PRP 180V 200MA DO-7	28480	1901-0033
A52CR8	1901-0033	2		DIODE-GEN PRP 180V 200MA DO-7	28480	1901-0033
A52CR9	1901-0033	2		DIODE-GEN PRP 180V 200MA DO-7	28480	1901-0033
A52CR10	1901-0662	3	4	DIODE-PWR RECT 100V 6A	04713	MR751
A52CR11	1901-0662	3		DIODE-PWR RECT 100V 6A	04713	MR751
A52CR12	1901-0662	3		DIODE-PWR RECT 100V 6A	04713	MR751
A52CR13	1901-0033	2		DIODE-GEN PRP 180V 200MA DO-7	28480	1901-0033
A52CR14	1901-0033	2		DIODE-GEN PRP 180V 200MA DO-7	28480	1901-0033
A52CR15	1901-0033	2		DIODE-GEN PRP 180V 200MA DO-7	28480	1901-0033
A52CR16	1901-0662	3		DIODE-PWR RECT 100V 6A	04713	MR751
A52DS1-3	1990-1147	8	3	LED-LAMP LUM-INT = 1MCD IF = 20MA-MAX BVR = 5V	28480	1990-1147
A52DS4	1990-1145	6	1	LED-LAMP LUM-INT = 1MCD IF = 20MA-MAX BVR = 5V	28480	1990-1145
A52F1	2110-0618	3	1	FUSE 5A 125V NTD 25X 27	28480	2110-0618
A52F2	2110-0332	8	1	FUSE 3A 125V 25X 27	28480	2110-0332
A52F3	2110-0249	6	1	FUSE 12A 250V NTD 1 25X 25 UL	28480	2110-0249
A52MP1	08340-20073	2	1	MTG BLOCK DIODE	28480	08340-20073
A52MP2	0520-0129	8	1	SCREW-MACH 2-56 312-IN-LG PAN-HD-POZI	00000	ORDER BY DESCRIPTION
A52MP3	2190-0014	1	1	WASHER-LK INTL T NO 2 089-IN-ID	28480	2190-0014
A52MP4	2950-0014	3	1	NUT-HEX-DBL-CHAM 1/4-28-THD 219-IN-THK	00000	ORDER BY DESCRIPTION
A52MP5	5040-6847	6	1	EXTRACTOR, RED	28480	5040-6847
A52MP6	1251-2313	6	4	CONN SGL CONN	28480	1251-2313
A52MP7	1251-2313	6	4	CONN SGL CONN	28480	1251-2313
A52MP8	1251-2313	6		CONN SGL CONN	28480	1251-2313
A52MP9	1251-2313	6		CONN SGL CONN	28480	1251-2313
A52MP10	5000-9043	6	1	PIN P C BOARD EXTRACTOR	28480	5000-9043
A52MP11	2110-0643	4	1	FUSEHOLDER-CLIP TYPE 15A 250 V	28480	2110-0643
A52MP12				NOT ASSIGNED		
A52MP13	8150-0014	3	1	WIRE 22AWG BL 300V PVC 7X30 105C	28480	8150-0014
A52MP14	2190-0027	6	1	WASHER-LK INTL T 1/4 IN 256-IN-ID	28480	2190-0027
A52Q1	1884-0018	5	2	THYRISTOR-SCR 2N4186 VRRM = 200	04713	2N4186
A52Q2	1884-0018	5		THYRISTOR-SCR 2N4186 VRRM = 200	04713	2N4186
A52Q3	1854-0477	7	4	TRANSISTOR NPN 2N2222A SI TO-18 PD = 500MW	04713	2N2222A
A52Q4	1854-0477	7		TRANSISTOR NPN 2N2222A SI TO-18 PD = 500MW	04713	2N2222A
A52Q5	1853-0213	7	1	TRANSISTOR PNP 2N4236 SI TO-5 PD = 1W	04713	2N4236
A52Q6	1854-0404	0	3	TRANSISTOR NPN SI TO-18 PD = 360MW	28480	1854-0404
A52Q7	1854-0404	0		TRANSISTOR NPN SI TO-18 PD = 360MW	28480	1854-0404
A52Q8	1854-0404	0		TRANSISTOR NPN SI TO-18 PD = 360MW	28480	1854-0404
A52Q9	1854-0477	7		TRANSISTOR NPN 2N2222A SI TO-18 PD = 500MW	04713	2N2222A
A52Q10	1854-0441	5	1	TRANSISTOR NPN SI PD = 5 8W FT = 800KHZ	28480	1854-0441
A52Q11	1884-0046	9	1	THYRISTOR-SCR VRRM = 50	03508	C230F
A52Q12	1854-0637	1	1	TRANSISTOR NPN 2N2219A SI TO-5 PD = 800MW	01295	2N2219A
A52Q13	1853-0281	9	1	TRANSISTOR PNP 2N2907A SI TO-18 PD = 400MW	04713	2N2907A
A52Q14	1853-0314	9	1	TRANSISTOR PNP 2N2905A SI TO-39 PD = 600MW	04713	2N2905A
A52Q15	1854-0477	7		TRANSISTOR NPN 2N2222A SI TO-18 PD = 500MW	04713	2N2222A
A52Q16	1853-0034	0	1	TRANSISTOR PNP SI TO-18 PD = 360MW	28480	1853-0034

A52 Positive Regulator Component-Level Troubleshooting

Table A52-5. A52 Positive Regulator Replaceable Parts

Reference Designation	HP Part Number	C	D	Qty	Description	Mfr Code	Mfr Part Number
A52R1	0812-0021	8		1	RESISTOR 47 5% 3W PW TC = 0 ± 90	91637	CW2B1-3-T2-47/100-J
A52R2	0811-4507	1		1	RESISTOR 56 5% 3W PW TC = 0 ± 90	28480	0811-4507
A52R3	0811-4506	0		3	RESISTOR 27 5% 3W PW TC = 0 ± 90	28480	0811-4506
A52R4	0811-4506	0		0	RESISTOR 27 5% 3W PW TC = 0 ± 90	28480	0811-4506
A52R5	0811-4506	0		0	RESISTOR 27 5% 3W PW TC = 0 ± 90	28480	0811-4506
A52R6	0757-0401	0		7	RESISTOR 100 1% 125W F TC = 0 ± 100	24546	C4-1/8-T0-101-F
A52R7	0757-0401	0		0	RESISTOR 100 1% 125W F TC = 0 ± 100	24546	C4-1/8-T0-101-F
A52R8	0757-0416	7		3	RESISTOR 511 1% 125W F TC = 0 ± 100	24546	C4-1/8-T0-511R-F
A52R9	0757-0442	9		7	RESISTOR 10K 1% 125W F TC = 0 ± 100	24546	C4-1/8-T0-1002-F
A52R10	0757-0394	0		1	RESISTOR 51 1 1% 125W F TC = 0 ± 100	24546	C4-1/8-T0-51R1-F
A52R11	0698-3150	6		1	RESISTOR 2 37K 1% 125W F TC = 0 ± 100	24546	C4-1/8-T0-2371-F
A52R12	0698-3442	9		2	RESISTOR 237 1% 125W F TC = 0 ± 100	24546	C4-1/8-T0-237R-F
A52R13	0757-0438	3		5	RESISTOR 5 11K 1% 125W F TC = 0 ± 100	24546	C4-1/8-T0-5111-F
A52R14	0757-0428	1		1	RESISTOR 1 62K 1% 125W F TC = 0 ± 100	24546	C4-1/8-T0-1621-F
A52R15	0757-0438	3		3	RESISTOR 5 11K 1% 125W F TC = 0 ± 100	24546	C4-1/8-T0-5111-F
A52R16	0757-0280	3		5	RESISTOR 1K 1% 125W F TC = 0 ± 100	24546	C4-1/8-T0-1001-F
A52R17	0757-0438	3		3	RESISTOR 5 11K 1% 125W F TC = 0 ± 100	24546	C4-1/8-T0-5111-F
A52R18	0698-8817	2		3	RESISTOR 2 61 1% 125W F TC = 0 ± 100	28480	0698-8817
A52R19	0757-0346	2		3	RESISTOR 10 1% 125W F TC = 0 ± 100	24546	C4-1/8-T0-10R0-F
A52R20	0698-3444	1		3	RESISTOR 316 1% 125W F TC = 0 ± 100	24546	C4-1/8-T0-316R-F
A52R21	0698-3447	4		1	RESISTOR 422 1% 125W F TC = 0 ± 100	24546	C4-1/8-T0-422R-F
A52R22	0757-0440	7		2	RESISTOR 7 5K 1% 125W F TC = 0 ± 100	24546	C4-1/8-T0-7501-F
A52R23	0757-0442	9		9	RESISTOR 10K 1% 125W F TC = 0 ± 100	24546	C4-1/8-T0-1002-F
A52R24	0698-3407	6		2	RESISTOR 1 96K 1% 5W F TC = 0 ± 100	28480	0698-3407
A52R25	0757-0442	9		9	RESISTOR 10K 1% 125W F TC = 0 ± 100	24546	C4-1/8-T0-1002-F
A52R26	0698-3407	6		6	RESISTOR 1 96K 1% 5W F TC = 0 ± 100	28480	0698-3407
A52R27	0698-3449	6		1	RESISTOR 28 7K 1% 125W F TC = 0 ± 100	24546	C4-1/8-T0-2872-F
A52R28	0757-0461	2		1	RESISTOR 68 1K 1% 125W F TC = 0 ± 100	24546	C4-1/8-T0-6812-F
A52R29*	0698-3154	0		1	RESISTOR 4 22K 1% 125W F TC = 0 ± 100	24546	C4-1/8-T0-4221-F
A52R30	0698-3442	9		9	RESISTOR 237 1% 125W F TC = 0 ± 100	24546	C4-1/8-T0-237R-F
A52R31	0698-8817	2		2	RESISTOR 2 61 1% 125W F TC = 0 ± 100	28480	0698-8817
A52R32	0698-3444	1		1	RESISTOR 316 1% 125W F TC = 0 ± 100	24546	C4-1/8-T0-316R-F
A52R33	0757-0346	2		2	RESISTOR 10 1% 125W F TC = 0 ± 100	24546	C4-1/8-T0-10R0-F
A52R34	0698-3445	2		1	RESISTOR 348 1% 125W F TC = 0 ± 100	24546	C4-1/8-T0-348R-F
A52R35	0757-0440	7		7	RESISTOR 7 5K 1% 125W F TC = 0 ± 100	24546	C4-1/8-T0-7501-F
A52R36	0698-0085	0		1	RESISTOR 2 61K 1% 125W F TC = 0 ± 100	24546	C4-1/8-T0-2611-F
A52R37	0757-0290	5		1	RESISTOR 6 19K 1% 125W F TC = 0 ± 100	19701	MF4C1/8-T0-6191-F
A52R38	0698-3155	1		1	RESISTOR 4 64K 1% 125W F TC = 0 ± 100	24546	C4-1/8-T0-4641-F
A52R39	0757-0279	0		4	RESISTOR 3 16K 1% 125W F TC = 0 ± 100	24546	C4-1/8-T0-3161-F
A52R40	0698-6348	0		1	RESISTOR 3K 1% 125W F TC = 0 ± 25	28480	0698-6348
A52R41	0698-0084	9		5	RESISTOR 2 15K 1% 125W F TC = 0 ± 100	24546	C4-1/8-T0-2151-F
A52R42	0698-0084	9		9	RESISTOR 2 15K 1% 125W F TC = 0 ± 100	24546	C4-1/8-T0-2151-F
A52R43	0698-0084	9		9	RESISTOR 2 15K 1% 125W F TC = 0 ± 100	24546	C4-1/8-T0-2151-F
A52R44	0698-0084	9		9	RESISTOR 2 15K 1% 125W F TC = 0 ± 100	24546	C4-1/8-T0-2151-F
A52R45	0698-8827	4		5	RESISTOR 1M 1% 125W F TC = 0 ± 100	28480	0698-8827
A52R46	0698-8827	4		4	RESISTOR 1M 1% 125W F TC = 0 ± 100	28480	0698-8827
A52R47	0698-8827	4		4	RESISTOR 1M 1% 125W F TC = 0 ± 100	28480	0698-8827
A52R48	0698-8827	4		4	RESISTOR 1M 1% 125W F TC = 0 ± 100	28480	0698-8827
A52R49	0757-0465	6		6	RESISTOR 100K 1% 125W F TC = 0 ± 100	24546	C4-1/8-T0-1003-F
A52R50	0698-0083	8		1	RESISTOR 1 96K 1% 125W F TC = 0 ± 100	24546	C4-1/8-T0-1961-F
A52R51	0757-0416	7		7	RESISTOR 511 1% 125W F TC = 0 ± 100	24546	C4-1/8-T0-511R-F
A52R52	0757-0416	7		7	RESISTOR 511 1% 125W F TC = 0 ± 100	24546	C4-1/8-T0-511R-F
A52R53	0757-0465	6		1	RESISTOR 100K 1% 125W F TC = 0 ± 100	24546	C4-1/8-T0-1003-F
A52R54	0757-0442	9		9	RESISTOR 10K 1% 125W F TC = 0 ± 100	24546	C4-1/8-T0-1002-F
A52R55	0757-0442	9		9	RESISTOR 10K 1% 125W F TC = 0 ± 100	24546	C4-1/8-T0-1002-F
A52R56	0698-8827	4		9	RESISTOR 1M 1% 125W F TC = 0 ± 100	28480	0698-8827
A52R57	0698-0084	9		9	RESISTOR 2 15K 1% 125W F TC = 0 ± 100	24546	C4-1/8-T0-2151-F
A52R58	0757-0442	9		9	RESISTOR 10K 1% 125W F TC = 0 ± 100	24546	C4-1/8-T0-1002-F
A52R59	0757-0438	3		3	RESISTOR 5 11K 1% 125W F TC = 0 ± 100	24546	C4-1/8-T0-5111-F
A52R60	0757-0438	3		3	RESISTOR 5 11K 1% 125W F TC = 0 ± 100	24546	C4-1/8-T0-5111-F
A52R61	0757-0420	3		1	RESISTOR 750 1% 125W F TC = 0 ± 100	24546	C4-1/8-T0-751-F
A52R62	0757-0279	0		0	RESISTOR 3 16K 1% 125W F TC = 0 ± 100	24546	C4-1/8-T0-3161-F
A52R63	0757-0401	0		0	RESISTOR 100 1% 125W F TC = 0 ± 100	24546	C4-1/8-T0-101-F
A52R64	0757-0159	5		1	RESISTOR 1K 1% 5W F TC = 0 ± 100	28480	0757-0159
A52R65	0698-8466	7		1	RESISTOR 942 5% 125W F TC = 0 ± 50	28480	0698-8466
A52R66	0757-0279	0		0	RESISTOR 3 16K 1% 125W F TC = 0 ± 100	24546	C4-1/8-T0-3161-F
A52R67	0757-0279	0		0	RESISTOR 3 16K 1% 125W F TC = 0 ± 100	24546	C4-1/8-T0-3161-F
A52R68	0698-8464	5		1	RESISTOR 12 6K 5% 125W F TC = 0 ± 50	28480	0698-8464
A52R69	0698-8817	2		2	RESISTOR 2 61 1% 125W F TC = 0 ± 100	28480	0698-8817
A52R70	0698-3444	1		1	RESISTOR 316 1% 125W F TC = 0 ± 100	24546	C4-1/8-T0-316R-F

A52 Positive Regulator Component-Level Troubleshooting

Table A52-5. A52 Positive Regulator Replaceable Parts

Reference Designation	HP Part Number	C D	Qty	Description	Mfr Code	Mfr Part Number
A52R71	0757-0346	2		RESISTOR 10 1% 125W F TC = 0 ± 100	24546	C4-1/8-T0-10R0-F
A52R72	0698-3443	0	1	RESISTOR 287 1% 125W F TC = 0 ± 100	24546	C4-1/8-T0-287R-F
A52R73	0698-0090	7	1	RESISTOR 464 1% 5W F TC = 0 ± 100	28480	0698-0090
A52R74	0757-0401	0		RESISTOR 100 1% 125W F TC = 0 ± 100	24546	C4-1/8-T0-101-F
A52R75	0757-0401	0		RESISTOR 100 1% 125W F TC = 0 ± 100	24546	C4-1/8-T0-101-F
A52R76	0757-0401	0		RESISTOR 100 1% 125W F TC = 0 ± 100	24546	C4-1/8-T0-101-F
A52R77	0757-0401	0		RESISTOR 100 1% 125W F TC = 0 ± 100	24546	C4-1/8-T0-101-F
A52R78	0757-0280	3		RESISTOR 1K 1% 125W F TC = 0 ± 100	24546	C4-1/8-T0-1001-F
A52R79	0757-0280	3		RESISTOR 1K 1% 125W F TC = 0 ± 100	24546	C4-1/8-T0-1001-F
A52R80	0757-0280	3		RESISTOR 1K 1% 125W F TC = 0 ± 100	24546	C4-1/8-T0-1001-F
A52R81	0757-0280	3		RESISTOR 1K 1% 125W F TC = 0 ± 100	24546	C4-1/8-T0-1001-F
A52R82	0698-7220	9	1	RESISTOR 215 1% 05W F TC = 0 ± 100	28480	0698-7220
A52R83	0698-3437	2	1	RESISTOR 133 1% 125W F TC = 0 ± 100	28480	0698-3437
A52TP1	0360-0535	0	7	TERMINAL TEST POINT PCB	00000	ORDER BY DESCRIPTION
A52TP2	0360-0535	0		TERMINAL TEST POINT PCB	00000	ORDER BY DESCRIPTION
A52TP3	0360-0535	0		TERMINAL TEST POINT PCB	00000	ORDER BY DESCRIPTION
A52TP4	0360-0535	0		TERMINAL TEST POINT PCB	00000	ORDER BY DESCRIPTION
A52TP5	0360-0535	0		TERMINAL TEST POINT PCB	00000	ORDER BY DESCRIPTION
A52TP6	0360-0535	0		TERMINAL TEST POINT PCB	00000	ORDER BY DESCRIPTION
A52TP7	0360-0535	0		TERMINAL TEST POINT PCB	00000	ORDER BY DESCRIPTION
A52U1	1820-0223	0	2	IC OP AMP GP TO-99 PKG	3L585	CA301AT
A52U2	1826-0742	0	1	IC V RGLTR-V-REF-FxD 10V TO5 PKG	28480	1826-0742
A52U3	1820-0223	0		IC OP AMP GP TO-99 PKG	3L585	CA301AT
A52U4	1826-0138	8	2	IC COMPARATOR GP QUAD 14-DIP-P PKG	01295	LM339N
A52U5	1820-1531	5	1	IC FF CMOS D-TYPE POS-EDGE-TRIG DUAL	3L585	CD4013AF
A52U6	1826-0138	8		IC COMPARATOR GP QUAD 14-DIP-P PKG	01295	LM339N
A52VR1	1902-3252	5	1	DIODE-ZNR 22 6V 2% DO-35 PD= 4W	28480	1902-3252
A52VR2	1902-3193	3	2	DIODE-ZNR 13 3V 5% DO-35 PD= 4W	28480	1902-3193
A52VR3	1902-0049	2	2	DIODE-ZNR 6 19V 5% DO-35 PD= 4W	28480	1902-0049
A52VR4	1902-0041	4	1	DIODE-ZNR 5 11V 5% DO-35 PD= 4W	28480	1902-0041
A52VR5	1902-3160	4	1	DIODE-ZNR 10V 2% DO-35 PD= 4W TC = + 06%	28480	1902-3160
A52VR6	1902-3193	3		DIODE-ZNR 13 3V 5% DO-35 PD= 4W	28480	1902-3193
A52VR7	1902-0049	2		DIODE-ZNR 6 19V 5% DO-35 PD= 4W	28480	1902-0049

A53 Negative Regulator Circuit Description

ASSEMBLY PURPOSE

The A53 assembly contains all circuitry for the -10V , -5.2V , and -40V power supplies, as well as voltage sensing circuitry to flag the A52 positive regulator assembly if one of these supplies goes out of tolerance.

NOTE: The -10 and -40V supplies are critical, low-noise supplies. They are limited to a periodic and random deviation (PAR) of less than $100\ \mu\text{V}$ peak. The -5.2V supply is primarily a digital (ECL) supply, and has a PAR specification of 5mV .

-10V REGULATOR (BLOCK A)

This power supply differs from many others in that the return side of the supply is regulated, and the unregulated side is common to the output. The motherboard darlington regulates the voltage difference between the -10V RETURN and ground. The amplitude of the -10V RETURN is regulated as necessary so that the -10V UNREG line is always -10V with respect to ground.

There is frequency compensation, and an output capacitor provides a minimum load capacitance and lower output impedance. Foldback current limiting is used as on the $+5.2$ and $+20\text{V}$ supplies.

The voltage at the base of the foldback transistor is set by a voltage divider. The voltage at one end of the divider is set by the voltage drop across the current sense resistors, and the voltage at the other end of the divider is set by the output voltage of the supply.

When the voltage at the base of the foldback transistor reaches 0.7V , the device conducts and removes some portion of the base current supplied to the motherboard darlington transistor by the error amplifier. When the output voltage of the supply is low (during turn on or short circuit) a relatively small sense resistor current brings the foldback transistor base voltage above threshold, which turns it on, limiting the current supplied to the motherboard darlington transistor.

-10V CROWBAR/SUPPLY ON INDICATOR (BLOCK B)

If the supply output exceeds approximately 11V , the zener conducts, biasing the crowbar SCR on, which shorts the supply output to ground, protecting load circuits from an overvoltage condition. A yellow LED shows the -10V supply operational status. The -10V supply tolerance is $-10\text{V} \pm 5\%$ (0.5V).

-5.2V REGULATOR (BLOCK C)

The -5.2V regulator is a monolithic three-terminal adjustable negative device. The adjustment terminal is nominally 1.25V more negative than the output terminal.

The reference capacitor increases ripple rejection for the regulator, and the protection diode provides a discharge path for the reference capacitor and protects load circuits from damage due to reverse polarity power caused by an instrument failure.

–5.2V CROWBAR/SUPPLY ON INDICATOR (BLOCK D)

If the –5.2V output exceeds approximately –6.2V, the zener conducts, biasing the crowbar SCR on, which shorts the –5.2V supply to ground. A yellow LED shows the operational status of the supply. The –5.2V supply tolerance is $-5.2V \pm 5\%$, or 0.26V.

–40V REGULATOR (BLOCK E)

This circuit is similar to the –10V regulator: the –40V return line is regulated, not the –40V unregulated line (see block A description).

The +20V REF provides reference for the regulator, and powers the error amplifier. An SCR limits the error amplifier negative supply. An input capacitor protects the error amplifier input stage.

Current limit operation is similar to the –10V current limit. Feedback is completed off the A53 assembly, using remote sense at the main –40V distribution point on the motherboard. –40V SENSE comes back on the A53 assembly to complete the loop. To reduce noise in the supply, ground reference connects to main ground at the edge fingers. A diode protects load circuits from reverse polarity supply caused by an instrument failure.

–40V CROWBAR/SUPPLY ON INDICATOR (BLOCK F)

If the –40V output exceeds approximately 44.2V, the zener conducts, biasing the crowbar SCR, which shorts the –40V supply to ground, protecting load circuits from an overvoltage condition. A yellow LED shows the supply operational status. The –40V supply tolerance is $-40V \pm 5\%$ (2.0V).

VOLTAGE SENSE (BLOCK H)

The –4.64V reference section provides a reference voltage to compare with each supply output. If a supply is out of regulation (low output), the corresponding supply comparator output goes low. This forces the output comparator output high, biasing the power up transistor on, which pulls HNUP (high negative up) low (for HNUP, high = +20V, low = +0.2V).

In the event of a crowbar (or short to ground) on the –10V supply, a clamp diode and a current limit resistor prevent the –40V supply from damaging the supply comparator. Output diodes isolate the supply comparator outputs, allowing you to check each supply independently.

GROUNDS AND COMMONS (BLOCK I)

This block shows the critical power and signal ground distribution system on the assembly.

A53 Negative Regulator Component-Level Troubleshooting

WARNING

When the instrument is connected to ac line power and/or the A19 power-on safety indicator LED is on, there are voltages present inside the instrument that can cause personal injury or death. Any servicing of this instrument with protective covers removed should be performed only by qualified personnel who are aware of the hazards involved.

CAUTION

The crowbar circuitry on this assembly protects the instrument, do not operate the supply without it.

To avoid non-repairable damage to assemblies, do not reinstall the A19, A35, A52, or A53 assemblies unless ac mains is disconnected from the instrument.

This assembly contains static sensitive components. Troubleshoot this assembly only at a work station equipped with an anti-static surface, and use a grounding strap that provides a path to ground of between 1 M Ω and 2.5 M Ω . Always handle printed circuit boards by the edges; never touch the finger contacts.

The thermal connection between the pass transistors/voltage regulators main heat sink is the dominant factor in the two devices' long term reliability. when installing or replacing either of these parts. Use only oil based thermal compound (HP Part Number 6040-0454 CD0).

DO NOT use silicone based thermal compound. Silicone based oil migrates past element sockets, switch contacts, or printed circuit board edge connectors, raising contact resistance, or electrically isolating the contacts. Silicone based thermal compounds disperse into the air, depositing themselves anywhere in the instrument. Heat increases the rate of dispersion.

HOW TO APPLY THERMAL COMPOUND

When installing or replacing a pass transistor or voltage regulator, apply thermal compound as follows:

1. Apply a thin coating of thermal compound (HP Part Number 6040-0454 CD0) to both sides of the insulating washer. The coating should provide a thin but continuous layer of compound from component-to-washer and washer-to-heat sink. An excessive amount of compound reduces its ability to transfer heat.
2. Tighten the pass element mounting screws with seven inch-pounds of force. Tightening with less force diminishes the heat transfer capability of the thermal compound. Tightening with greater force can damage the mounting hardware.

–10V REGULATOR

The –10V supply tolerance is $-10V \pm 5\%$, or 0.5V

1. Ensure that the –5.2V supply (crowbar, etc) is not pulling the –10V supply down.
2. Remove the –5.2V fuse (F1). If the –10V supply still does not function, proceed as follows:

SUPPLY/LOAD FAILURE DETERMINATION

1. Unplug the instrument from ac line power.
2. After the power-on safety indicator goes out, remove the A53 assembly and place it on an extender board.
3. Before installing the extender board in the instrument, apply thin, non-conductive tape to the extender board –10V output fingers (use colored tape, if possible, to make it highly visible, so you remember to remove it when you are through troubleshooting). **Do not** apply tape to the A53 assembly fingers.
4. Re-install the A53 assembly and connect the instrument to ac line power. If the power supply now operates properly suspect a short on one of the instrument assemblies that use –10V. Refer to Table A53-1, for a list of these assemblies.

Table A53-1. A53 Power Supply Destination Chart

Power Supply	Destination Assemblies/Connectors
–10V	A21 through A28, A34, A36, A38 through A43, A54, A55, A57 through A61, A62J2, A62J18, A62J19
–40V	A22, A23, A28, A34, A40, A54, A55, A56, A62J2, A62J19
–5.2V	A23, A27, A34, A52, A57 through A61, A62J1, A62J2, A62J19

5. Remove the tape from extender board fingers and clean the fingers using the following procedure.

CAUTION

NEVER clean PC board fingers with an eraser. **NEVER** use tap water in the cleaning solution. Chloride contamination from tap water, from salt (skin contact), or from any other source, can cause reliability problems. Always wear a ground strap when handling any internal component or assembly.

How to Clean Printed Circuit Board Fingers

1. Mix one part de-ionized (or de-chlorinated) water with two parts isopropyl alcohol.
2. Apply this solution to a clean, lint free, cloth (HP Part Number 9310-0039 CD3).
3. Rub the PC board fingers carefully, then dry them with a clean part of the cloth.

– 10V LOAD FAILURE

1. After performing the above procedure, and cleaning the extender board fingers, reinstall the A53 assembly.

NOTE: Always unplug the instrument from ac line power and wait for the power-on safety indicator to go out before removing or installing any assembly or cable.

2. One at a time, remove each assembly that uses –10V, and determine which one is faulty.
3. Remove any cables that carry the affected supply (see Table A53-1)

– 10V POWER SUPPLY FAILURE

If the power supply output does not return to normal after you tape off the extender board –10V output fingers, refer to the following:

The – 10V Output Voltage is Approximately –0.8 to –1.0V

1. Crowbar Circuit Verification

If the output voltage is approximately –0.8 to –1.0V the crowbar circuit is engaged.

- a. Connect the instrument to a auto-transformer set for 0V output.
- b. While monitoring the supply output voltage, slowly increase the auto-transformer output voltage. If the crowbar fires before the supply output reaches –10V suspect VR1.

2. Regulator Verification

- a. If the power supply output reaches -10V , stop increasing auto-transformer voltage.
- b. The emitter-base voltage of A62Q1 should be approximately 1.2V . Check for an emitter-collector short.
- c. The emitter-base voltage of Q4 should be 0.35 to 0.5V . Check for an emitter-collector short.

The -10V Output Voltage is Approximately 0 to $+0.7\text{V}$

1. Initial Checks

- a. Ensure that ac line voltage is nominal, and that the line voltage selector cam is installed properly in the line filter module, FL1.
- b. Ensure that the proper fuse value is installed
- c. If the line voltage and fuse are correct, and the power supply input fuse (F3) is blown, suspect transistor A62Q1.
- d. Measure the -10V RETURN (P1-2) with respect to -10V UNREG (P1-9). If this voltage is less than approximately -16V , troubleshoot the -10V rectifier (refer to A19 troubleshooting)

2. Regulator Verification

- a. Check the base-emitter voltage of A62Q1. It should be approximately 1.2V .
- b. Check the base-emitter voltage of Q4. It should be 0.35 to 0.5V .

3. Current Limit Checks

- a. Check for 0.6V across the emitter-base junction of Q4. This indicates that the current foldback circuit is engaged, and is shutting down A62Q1.
- b. Check the emitter-collector voltage of Q4. If the voltage is approximately 0.2V or less, Q4 may be shorted.
- c. Examine the -10V supply for burnt or discolored components.
- d. Suspect a shorted capacitor, diode, or crowbar SCR if the procedures above do not isolate the problem.

The -10V Output Voltage is Incorrect (Tolerance is $-10\text{V} \pm 0.5\text{V}$)

- a. Ensure that ac mains voltage is nominal and that the line voltage selector cam is installed with the proper line voltage selected
- b. Measure the -10V RETURN (P1-2) with respect to -10V UNREG (P1-9). If the voltage is less than approximately -16V , troubleshoot the -10V Rectifier (see A19 troubleshooting).
- c. With an oscilloscope, check the output voltage for oscillations.
- d. Check the values of divider resistors R8, R9, and R10. Ensure that the feedback path to U4 is not open.
- e. Check C5 by removing it from the circuit. C5 can cause supply noise or temperature instability if it leaks.

–40V REGULATOR

The –40V supply tolerance is $\pm 5\%$ (2 0V)

1. Because the –40V regulator circuit is very similar to the –10V regulator circuit, troubleshooting techniques are very similar. Refer to the –10V regulator troubleshooting, above. The major difference between the two supplies is that while the –10V supply uses a darlington series pass element for supply regulation, the –40V supply uses a discrete transistor.

NOTE: Along with the –40V output pins, tape –40V sense, and jumper the anode of CR12 to TP4.

2. When you check for proper A62Q2 operation, measure its base-emitter voltage. If this voltage is not approximately 0.6V to 0.7V, suspect A62Q2.

–5.2V REGULATOR

The –5.2V supply tolerance is $\pm 5\%$ (0.26V).

1. Determine if the –5.2V supply has failed or is being forced into current limit by a short elsewhere in the instrument (see SUPPLY/LOAD FAILURE DETERMINATION, above). If the problem is load related, troubleshoot similar to the –10V Load Failure section. If the –5.2V supply is at fault, proceed as follows:

–5.2V POWER SUPPLY FAILURE

If the power supply output does not return to normal after the extender board –5.2V output pins are taped off, refer to the appropriate sections below:

The –5.2V Output Voltage is Approximately –0.8 to –1.0V

1. Crowbar Circuit Verification

If the output voltage is approximately –0.8 to –1.0V the crowbar circuit is engaged.

- a. Connect the instrument to a auto-transformer set for 0V output.
- b. While monitoring the supply output voltage, slowly increase the auto-transformer output voltage. If the crowbar fires before the supply output reaches –5.2V suspect VR2.

2. Regulator Verification

- a. If the power supply output reaches –5.2V, stop increasing auto-transformer voltage.
- b. Measure the voltage across pin 1 and the case of U1. If the voltage is not approximately 1.25V, suspect U1.
- c. Measure the voltage between the input and output of U1. If there is little or no voltage, U1 is probably shorted.

The -5.2V Output Voltage is Approximately 0V

1. Initial Checks
 - a. Ensure that ac mains voltage is nominal, and that the line voltage selector PC board is installed properly in the line filter module, FL1.
 - b. Ensure that the proper fuse value is installed.
 - c. If the line voltage and fuse are correct, and the power supply input fuse (F1) is blown, suspect regulator U1.
2. Regulator Verification
 - a. Measure the -10V REGULATOR output (TP5). If this voltage is incorrect, troubleshoot the -10V power supply.
 - b. Measure across pin 1 and the case of U1. If the voltage is not approximately 1.25V , suspect U1.
 - c. Examine the -5.2V supply for burnt or discolored components.
 - d. Suspect a shorted capacitor, diode, or crowbar SCR if the procedures above do not isolate the problem.

The -5.2V Output Voltage is Incorrect (Tolerance is $-5.2\text{V} \pm 0.26\text{V}$)

1. Ensure that ac mains voltage is nominal and that the line voltage selector cam is installed with the proper line voltage selected.
2. Measure the -10V REGULATOR output (TP5). If the voltage is incorrect, troubleshoot the -10V power supply.
3. With an oscilloscope, check the output voltage for oscillations.
4. If the output is approximately 1.25V , C14 is probably shorted.

Table A53-2. A53 Negative Regulator Supply Limits

Power Supply	A53 TP	Ground	Limits
-40V	4	P1-14	-42.00 to -38.00V
-10V	5	P1-14	-10.5 to -9.5V
-5.2V	3	P1-14	-5.46 to -4.94V

A56 –15V Regulator Circuit Description

ASSEMBLY PURPOSE

The A56 assembly contains the –15V regulator and voltage sense circuitry to flag the A52 positive regulator if an out-of-tolerance condition occurs in the supply.

–15V REGULATOR (BLOCK A)

The –15V regulator is a monolithic three-terminal adjustable negative device, designed to maintain a constant 1.25V difference between the OUT terminal and the ADJ terminal.

An output capacitor improves the regulator ripple rejection, and a protection diode provides a discharge path for the output capacitor in the event of a short from the –15V output to ground. An output diode protects against an inadvertent short between the –15V output and a high current positive supply (clamps –15V OUT at approximately +0.8V, protecting load circuits from damage).

–15V CROWBAR/SUPPLY ON INDICATOR (BLOCK B)

If the –15V output exceeds approximately –17.8 Volts, the zener conducts, biasing the crowbar SCR, which shorts the –15V supply to ground, protecting instrument load circuits from an over-voltage condition. A yellow LED shows the supply status. The –15V supply tolerance is $\pm 5\%$, or 0.75V.

LOW VOLTAGE SENSE (BLOCK C)

If the –15V output exceeds –12.1V, the output transistor turns off and HNUP (high negative up) goes high. HNUP is used on the A52 positive regulator assembly to monitor the –15V output and determine if it is within tolerance.

A56 – 15V Regulator Component-Level Troubleshooting



The crowbar circuitry on this assembly protects the instrument, do not operate the supply without it.

This assembly contains static sensitive components. Troubleshoot this assembly only at a work station equipped with an anti-static surface, and use a grounding strap that provides a path to ground of between 1 M Ω and 2.5 M Ω . Always handle printed circuit boards by the edges; never touch the finger contacts.

The thermal connection between the pass transistors/voltage regulators main heat sink is the dominant factor in the two devices' long term reliability. when installing or replacing either of these parts. Use only oil based thermal compound (HP Part Number 6040-0454 CD0).

DO NOT use silicone based thermal compound. Silicone based oil migrates past element sockets, switch contacts, or printed circuit board edge connectors, raising contact resistance, or electrically isolating the contacts. Silicone based thermal compounds disperse into the air, depositing themselves anywhere in the instrument. Heat increases the rate of dispersion.

HOW TO APPLY THERMAL COMPOUND

When installing or replacing a pass transistor or voltage regulator, apply thermal compound as follows:

1. Apply a thin coating of thermal compound (HP Part Number 6040-0454 CD0) to both sides of the insulating washer. The coating should provide a thin but continuous layer of compound from component-to-washer and washer-to-heatsink. An excessive amount of compound reduces its ability to transfer heat.
2. Tighten the pass element mounting screws with seven inch-pounds of force. Tightening with less force diminishes the heat transfer capability of the thermal compound. Tightening with greater force can damage the mounting hardware.

Because the –15V supply is very similar to the –5.2V supply, its troubleshooting techniques are similar. Refer to the –5.2V REGULATOR troubleshooting section, above.

The –15V supply tolerance is $\pm 5\%$ (0.75V).

A56 -15V Regulator Component-Level Troubleshooting

Table A56-1. A56 Power Supply Destination Chart

Power Supply	Destination Assemblies
-15V	A27, A28, A54, A57 through A61

Table A56-2 A56 -15V Regulator Limit

Power Supply	A56 TP	Ground	Limit
-15V	TP2	P1-5	-15 75V to -14 25V

A56 – 15V Regulator Component-Level Troubleshooting

Table A53-3. A53 Negative Regulator P1 Pin I/O

Pin	Mnemonic	Levels	Source	Destination
1 19	Q2E Q2E		A62Q2-EMITTER A62Q2-EMITTER	E E
2 20	-10V RETURN -10V RETURN	+6.4V AT 13.3 GHZ +6.4V AT 13.3 GHZ	A62Q1-COLLECTOR A62Q1-COLLECTOR	XA19P1-7, 8, 19, 20 A XA19P1-7, 8, 19, 20 A
3 21	-40V RETURN Q2B	12.7 AT 13.3 GHZ	A62Q2-COLLECTOR A62Q2-BASE	*E E
4 22	Q1B -40V RETURN	12.7V AT 13.3 GHZ	A62Q1-BASE A62Q2-COLLECTOR	A *E
5 23	-40V SENSE (+) -40V SENSE (-)	0V -40V	D E	*E *
6 24	-40V UNREG -40V UNREG	-40V -40V	XA35P1-6, 24 XA35P1-6, 24	*E *E
7 25	Q1E Q1E		A62Q1-EMITTER A62Q1-EMITTER	A A
8 26	Q1E Q1E		A62Q1-EMITTER A62Q1-EMITTER	A A
9 27	-10V UNREG -10V UNREG	-10V -10V	XA19P1-11, 12, 23, 24 XA19P1-11, 12, 23, 24	A A
10 28	-10V UNREG -10V UNREG	-10V -10V	XA19P1-11, 12, 23, 24 XA19P1-11, 12, 23, 24	A A
11 29	-40V +20V	-40V +20V	E F XA52P1-16, 40	*H *A E H
12 30	-10V -40V	-10V -40V	A B E F	*C G H *H
13 31	-10V -10V	-10V -10V	A B A B	*C G H *C G H
14 32	GND -10V	0V -10V	A62 STAR GND A B	*D *C G H
15 33	GND GND	0V 0V	A62 STAR GND A62 STAR GND	*D *D
16 GND 34	0V GND	A62 STAR GND 0V	*D A62 STAR GND	*D *D
17 35	HNUP GND	TTL (HIGH TRUE) 0V	*H A62 STAR GND	* *D
18 36	-5.2V -5.2V	-5.2V -5.2V	C D C D	*H *H

A single letter in the source or destination column refers to a function block on this assembly schematic.

An asterisk (*) denotes multiple sources or destinations; refer to the A62 motherboard wiring list for a complete representation of signal sources and destinations.

A56 –15V Regulator Component-Level Troubleshooting

Table A56-4. A56 –15V Regulator P1 I/O

Pin	Mnemonic	Levels	Source	Destination
1 16	HNUP HNUP	TTL (HIGH TRUE) TTL (HIGH TRUE)	*C *C	* *
2 17				
3 18	-40V/-40V SENSE(-) -40V/-40V SENSE (-)	-40V -40V	XA53P1-11, 30/XA53P1-23 XA53P1-11, 30/XA53P1-23	*A *A
4 19	-10V -10V	-10V -10V	XA53P1-12, 13, 31, 32 XA53P1-12, 13, 31, 32	*NOT USED *NOT USED
5 20	GND GND	0V 0V	A62 STAR GND A62 STAR GND	*D *D
6 21				
7 22				
8 23				
9 24				
10 25				
11 26				
12 27				
13 28				
14 29				
14 30	-15V -15V	-15V -15V	A B A B	*C *C

A single letter in the source or destination column refers to a function block on this assembly schematic.

An asterisk (*) denotes multiple sources or destinations; refer to the A62 motherboard wiring list for a complete representation of signal sources and destinations

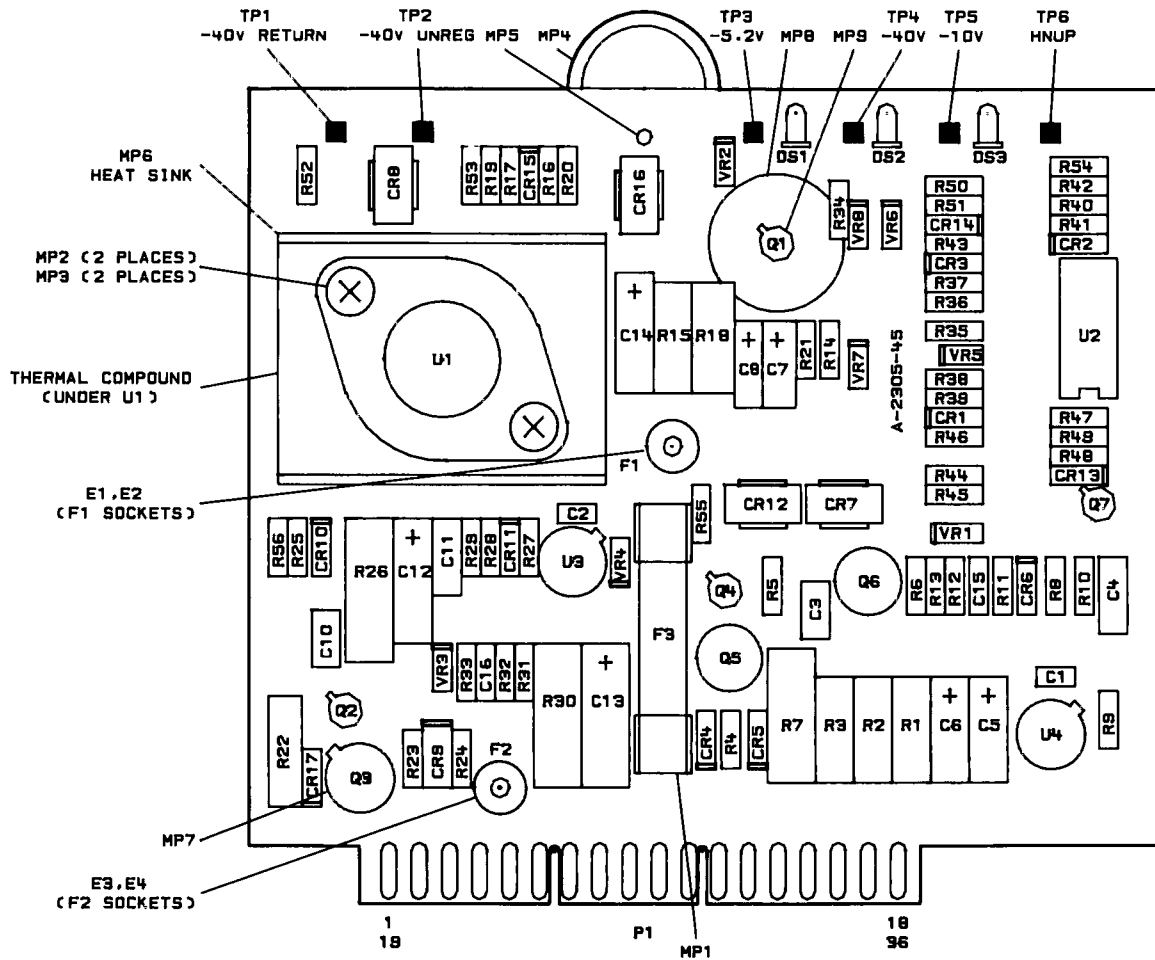
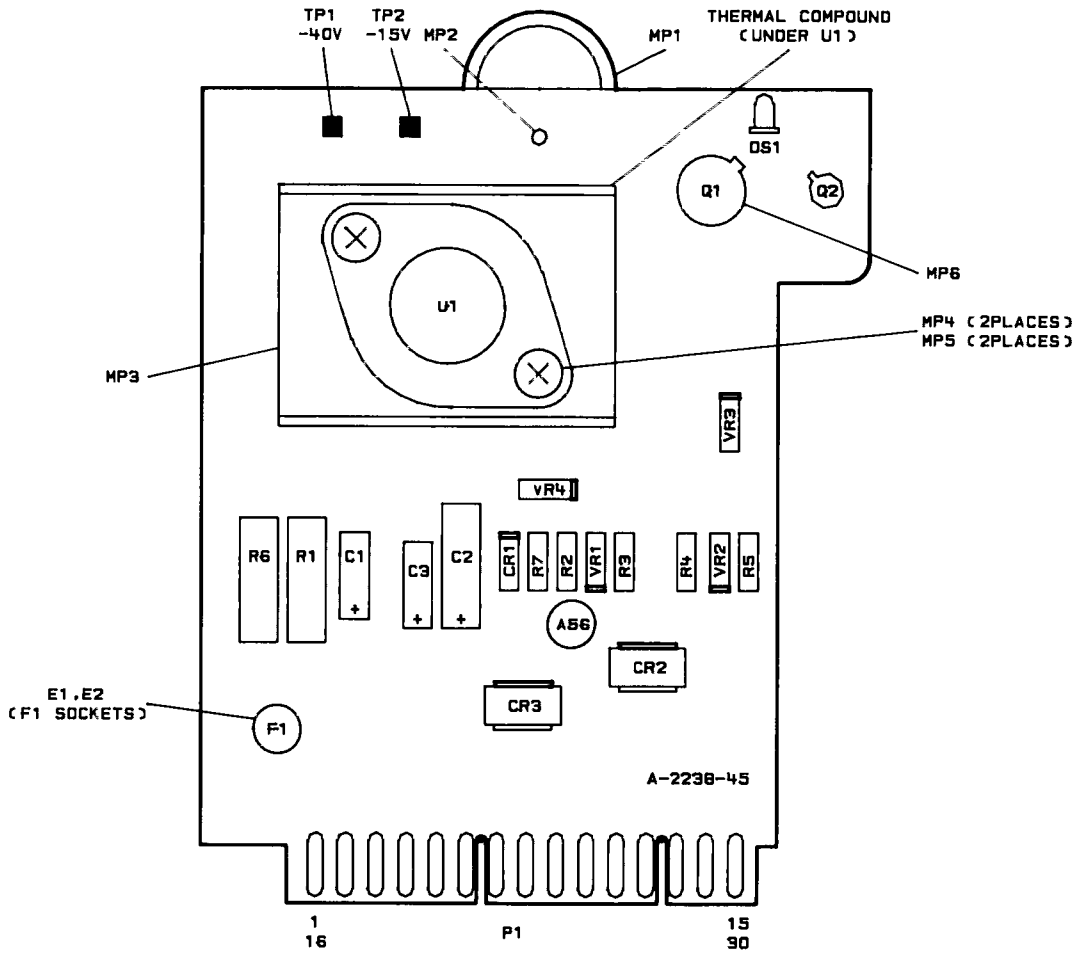

Figure A56-1. A53 Negative Regulator Component Location Diagram

A56 - 15V Regulator Component-Level Troubleshooting



HP Part Number: 08340-60029

Figure A56-2. A56 - 15V Regulator Component Location Diagram

NOTES:
 1. RESISTANCE VALUES SHOWN ARE IN OHMS UNLESS INDICATED OTHERWISE IN MICROHMS, UNLESS OTHERWISE NOTED.
 2. AS207, Q2.
 3. AS201, Q2.

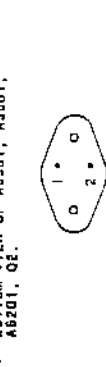

AS201, Q2 ARE MOUNTED ON THE HEAT SINK THROUGH THE REAR PANEL

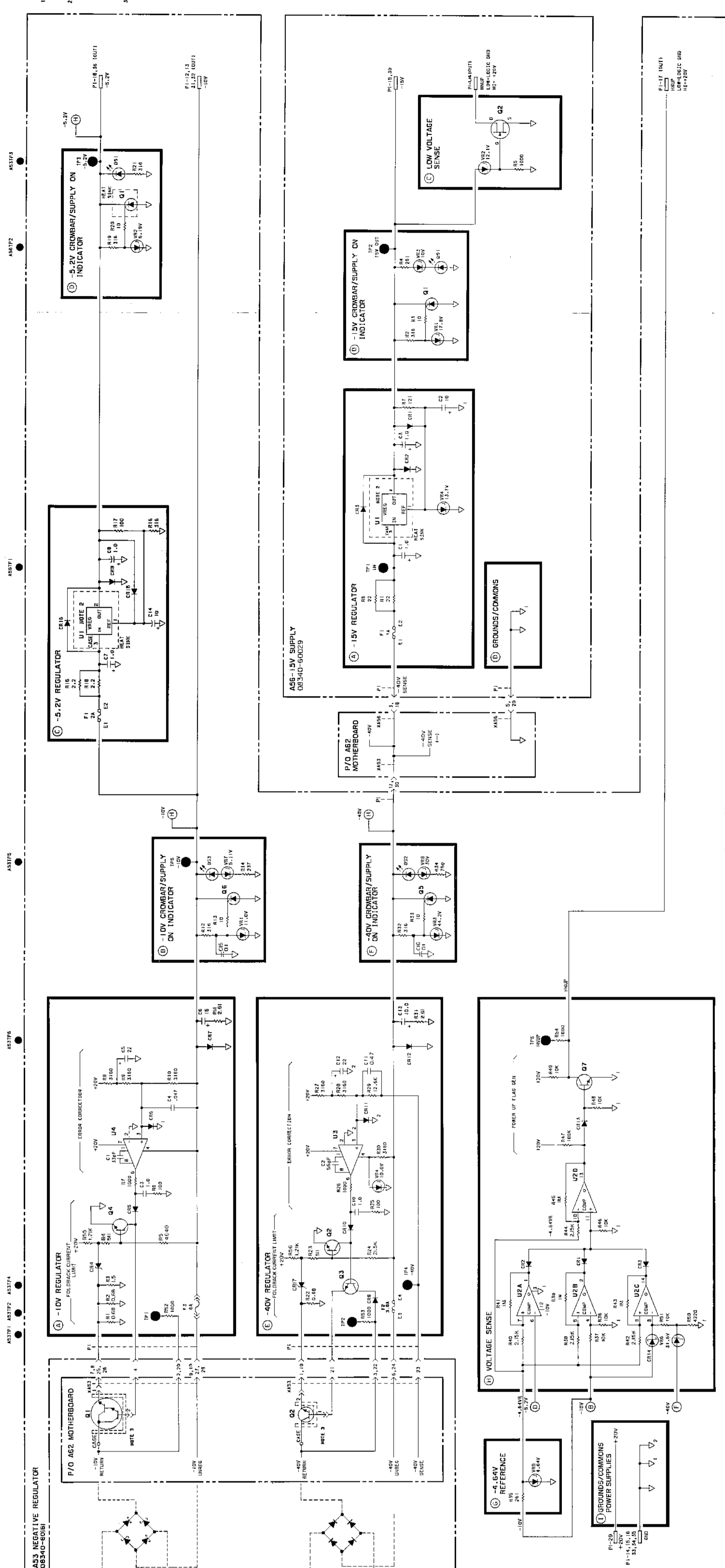

Figure A56-3. A53 Negative Regulator and A55 -15V Regulator, Schematic Diagram
 Power Supplies A56-9/A56-10

A56 — 15V Regulator Component-Level Troubleshooting

Table A56-5. A53 Negative Regulator Replaceable Parts

Reference Designation	HP Part Number	C D	Qty	Description	Mfr Code	Mfr Part Number
A53	08340-60161	4	1	NEGATIVE REGULATOR ASSEMBLY	28480	08340-60161
A53C1	0160-4807	3	1	CAPACITOR-FXD 33PF ±5% 100VDC CER 0±30	28480	0160-4807
A53C2	0160-4804	0		CAPACITOR-FXD 56PF ±5% 100VDC CER 0±30	28480	0160-4804
A53C3	0160-4535	4	2	CAPACITOR-FXD 1UF ±10% 50VDC CER	28480	0160-4535
A53C4	0160-4834	6	2	CAPACITOR-FXD 047UF ±10% 100VDC CER	28480	0160-4834
A53C5	0180-0228	6	2	CAPACITOR-FXD 22UF ±10% 15VDC TA	56289	150D226X9015B2
A53C6	0180-1746	5	1	CAPACITOR-FXD 15UF ±10% 20VDC TA	56289	150D156X9020B2
A53C7	0180-0291	3	2	CAPACITOR-FXD 1UF ±10% 35VDC TA	56289	150D105X9035A2
A53C8	0180-0291	3		CAPACITOR-FXD 1UF ±10% 35VDC TA	56289	150D105X9035A2
A53C9				NOT ASSIGNED		
A53C10	0160-4535	4		CAPACITOR-FXD 1UF ±10% 50VDC CER	28480	0160-4535
A53C11	0160-4834	6		CAPACITOR-FXD 047UF ±10% 100VDC CER	28480	0160-4834
A53C12	0180-0228	6		CAPACITOR-FXD 22UF ±10% 15VDC TA	56289	150D226X9015B2
A53C13	0180-2610	4	1	CAPACITOR-FXD 10UF ±10% 75VDC TA	00904	T110A106K075AS
A53C14	0180-0374	3	1	CAPACITOR-FXD 10UF ±10% 20VDC TA	56289	150D106X9020B2
A53C15	0160-4835	7	2	CAPACITOR-FXD 1UF ±10% 50VDC CER	02798	CAC04X7R104K050A
A53C16	0160-4835	7	2	CAPACITOR-FXD 1UF ±10% 50VDC CER	02798	CAC04X7R104K050
A53CR1	1901-0033	2	9	DIODE-GEN PRP 180V 200MA DO-7	28480	1901-0033
A53CR2	1901-0033	2		DIODE-GEN PRP 180V 200MA DO-7	28480	1901-0033
A53CR3	1901-0033	2		DIODE-GEN PRP 180V 200MA DO-7	28480	1901-0033
A53CR4	1901-1068	5	2	DIODE-SCHOTTKY SM SIG	28480	1901-1068
A53CR5	1901-0033	2		DIODE-GEN PRP 180V 200MA DO-7	28480	1901-0033
A53CR6	1901-0033	2		DIODE-GEN PRP 180V 200MA DO-7	28480	1901-0033
A53CR7	1901-0662	3	4	DIODE-PWR RECT 100V 6A	04713	MR751
A53CR8	1901-0662	3		DIODE-PWR RECT 100V 6A	04713	MR751
A53CR9	1901-0028	5	1	DIODE-PWR RECT 400V 750MA DO-29	28480	1901-0028
A53CR10	1901-0033	2		DIODE-GEN PRP 180V 200MA DO-7	28480	1901-0033
A53CR11	1901-0033	2		DIODE-GEN PRP 180V 200MA DO-7	28480	1901-0033
A53CR12	1901-0662	3		DIODE-PWR RECT 100V 6A	04713	MR751
A53CR13	1901-0033	2		DIODE-GEN PRP 180V 200MA DO-7	28480	1901-0033
A53CR14	1901-0518	8	1	DIODE-SM SIG SCHOTTKY	28480	1901-0518
A53CR15	1901-0033	2		DIODE-GEN PRP 180V 200MA DO-7	28480	1901-0033
A53CR16	1901-0662	3		DIODE-PWR RECT 100V 6A	04713	MR751
A53CR17	1901-1068	5		DIODE-SCHOTTKY SM SIG	28482	1901-1068
A53DS1	1990-1148	9	3	LED-LAMP LUM-INT=1MCD IF=20MA-MAX BVR=5V	28480	1990-1148
A53DS2	1990-1148	9		LED-LAMP LUM-INT=1MCD IF=20MA-MAX BVR=5V	28480	1990-1148
A53DS3	1990-1148	9		LED-LAMP LUM-INT=1MCD IF=20MA-MAX BVR=5V	28480	1990-1148
A53E1	1251-2313	6	4	CONNECTOR-SGL CONT SKT 04-IN-BSC-SZ RND	28480	1251-2313
A53E2	1251-2313	6		CONNECTOR-SGL CONT SKT 04-IN-BSC-SZ RND	28480	1251-2313
A53E3	1251-2313	6		CONNECTOR-SGL CONT SKT 04-IN-BSC-SZ RND	28480	1251-2313
A53E4	1251-2313	6		CONNECTOR-SGL CONT SKT 04-IN-BSC-SZ RND	28480	1251-2313
A53F1	2110-0425	0	1	FUSE 2A 125V 25X 27	28480	2110-0425
A53F2	2110-0332	8	1	FUSE 3A 125V 25X 27	28480	2110-0332
A53F3	2110-0056	3	1	FUSE 6A 250V NTD 1 25X 25 UL IEC	75915	312006
A53MP1	2110-0643	4	1	FUSEHOLDER-CLIP TYPE 15A 250 V	28480	2110-0643
A53MP2	0590-0526	6	1	THREADED INSERT-NUT 4-40 065-IN-LG SST	28480	0590-0526
A53MP3	2200-0105	4	1	SCREW-MACH 4-40 .312-IN-LG PAN-HD-POZI	00000	ORDER BY DESCRIPTION
A53MP4	5040-6852	3	1	EXTRACTOR ORANGE	28480	5040-6852
A53MP5	5000-9043	6	1	PIN P C BOARD EXTRACTOR	28480	5000-9043
A53MP6	85662-00029	7	1	HEAT SINK	28480	85662-00029
A53MP7				NOT ASSIGNED		
A53MP8	1205-0011	0	1	HEAT SINK TO-5/TO-39-CS	28480	1205-0011
A53MP9	1200-0173	5		INSULATOR-XSTR DAP-GL	28480	1200-0173
A53Q1	1884-0244	9	1	THYRISTOR-SCR VRRM=400	3L585	S2600D
A53Q2	1854-0404	0	2	TRANSISTOR NPN SI TO-18 PD=360MW	28480	1854-0404
A53Q3	1854-0271	9	1	TRANSISTOR NPN SI TO-39 PD=1W FT=150MHZ	28480	1854-0271
A53Q4	1854-0404	0		TRANSISTOR NPN SI TO-18 PD=360MW	28480	1854-0404
A53Q5	1884-0018	5	2	THYRISTOR-SCR 2N4186 VRRM=200	04713	2N4186
A53Q6	1884-0018	5		THYRISTOR-SCR 2N4186 VRRM=200	04713	2N4186
A53Q7	1854-0477	7	1	TRANSISTOR NPN 2N2222A SI TO-18 PD=500MW	04713	2N2222A
A53R1	0811-1079	6	3	RESISTOR 68 5% 3W PW TC=0±90	91637	CW2B1-3-T2-68/100-J
A53R2	0811-1079	6		RESISTOR 68 5% 3W PW TC=0±90	91637	CW2B1-3-T2-68/100-J
A53R3	0811-1220	9	1	RESISTOR 1.5 5% 3W PW TC=0±50	05524	CW-2B-39
A53R4	0757-0416	7	2	RESISTOR 511 1% 125W F TC=0±100	03292	C4-1/8-T0-511R-F
A53R5	0698-3155	1	1	RESISTOR 4 64K 1% 125W F TC=0±100	03292	C4-1/8-T0-4641-F
A53R6	0757-0401	0	3	RESISTOR 100 1% 125W F TC=0±100	24546	C4-1/8-T0-101-F
A53R7	0757-0159	5	2	RESISTOR 1K 1% 5W F TC=0±100	28480	0757-0159
A53R8	0757-0279	0	5	RESISTOR 3 16K 1% 125W F TC=0±100	24546	C4-1/8-T0-3161-F
A53R9	0757-0279	0		RESISTOR 3 16K 1% 125W F TC=0±100	24546	C4-1/8-T0-3161-F
A53R10	0757-0279	0		RESISTOR 3 16K 1% 125W F TC=0±100	24546	C4-1/8-T0-3161-F

A56 – 15V Regulator Component-Level Troubleshooting

Table A56-5. A53 Negative Regulator Replaceable Parts

Reference Designation	HP Part Number	C D	Qty	Description	Mfr Code	Mfr Part Number
A53R11	0698-8817	2	2	RESISTOR 2 61 1% 125W F TC=0±100	28480	0698-8817
A53R12	0698-3444	1	5	RESISTOR 316 1% 125W F TC=0±100	24546	C4-1/8-T0-316R-F
A53R13	0757-0346	2	3	RESISTOR 10 1% 125W F TC=0±100	24546	C4-1/8-T0-10R0-F
A53R14	0698-3442	9	1	RESISTOR 237 1% 125W F TC=0±100	24546	C4-1/8-T0-237R-F
A53R15	0811-1080	9	2	RESISTOR 2 2 5% 3W PW TC=0±50	28480	0811-1080
A53R16	0698-3444	1		RESISTOR 316 1% 125W F TC=0±100	24546	C4-1/8-T0-316R-F
A53R17	0757-0401	0		RESISTOR 100 1% 125W F TC=0±100	24546	C4-1/8-T0-101-F
A53R18	0811-1080	9		RESISTOR 2 2 5% 3W PW TC=0±50	28480	0811-1080
A53R19	0698-3444	1		RESISTOR 316 1% 125W F TC=0±100	24546	C4-1/8-T0-316R-F
A53R20	0757-0346	2		RESISTOR 10 1% 125W F TC=0±100	24546	C4-1/8-T0-10R0-F
A53R21	0698-3444	1		RESISTOR 316 1% 125W F TC=0±100	24546	C4-1/8-T0-316R-F
A53R22	0811-1079	6	1	RESISTOR 68 5% 3W PW TC=0±90	28480	0811-1079
A53R23	0757-0416	7		RESISTOR 511 1% 125W F TC=0±100	03292	C4-1/8-T0-511R-F
A53R24	0757-0199	3	1	RESISTOR 21 5K 1% 125W F TC=0±100	03292	C4-1/8-T0-2152-F
A53R25	0757-0401	0		RESISTOR 100 1% 125W F TC=0±100	24546	C4-1/8-T0-101-F
A53R26	0757-0159	5		RESISTOR 1k 1% 5W F TC=0±100	28480	0757-0159
A53R27	0757-0279	0		RESISTOR 3 16k 1% 125W F TC=0±100	24546	C4-1/8-T0-3161-F
A53R28	0757-0279	0		RESISTOR 3 16k 1% 125W F TC=0±100	24546	C4-1/8-T0-3161-F
A53R29	0698-8464	5	1	RESISTOR 12 6k 5% 125W F TC=0±50	28480	0698-8464
A53R30	0698-3410	1	1	RESISTOR 3 16k 1% 5W F TC=0±100	28480	0698-3410
A53R31	0698-8817	2		RESISTOR 2 61 1% 125W F TC=0±100	28480	0698-8817
A53R32	0698-3444	1		RESISTOR 316 1% 125W F TC=0±100	24546	C4-1/8-T0-316R-F
A53R33	0757-0346	2		RESISTOR 10 1% 125W F TC=0±100	24546	C4-1/8-T0-10R0-F
A53R34	0757-0420	3	1	RESISTOR 750 1% 125W F TC=0±100	24546	C4-1/8-T0-751-F
A53R35	0698-3132	4	1	RESISTOR 261 1% 125W F TC=0±100	24546	C4-1/8-T0-2610-F
A53R36	0757-0442	9	9	RESISTOR 10k 1% 125W F TC=0±100	24546	C4-1/8-T0-1002-F
A53R37	0757-0442	9		RESISTOR 10k 1% 125W F TC=0±100	24546	C4-1/8-T0-1002-F
A53R38	0698-0084	9	4	RESISTOR 2 15k 1% 125W F TC=0±100	03292	C4-1/8-T0-2151-F
A53R39	0698-8827	4	4	RESISTOR 1M 1% 125W F TC=0±100	03292	C4-1/8-T0-2151-F
A53R40	0698-0084	9		RESISTOR 2 15k 1% 125W F TC=0±100	03292	C4-1/8-T0-2151-F
A53R41	0698-8827	4		RESISTOR 1M 1% 125W F TC=0±100	03292	CT4
A53R42	0698-0084	9		RESISTOR 2 15k 1% 125W F TC=0±100	03292	C4-1/8-T0-2151-F
A53R43	0698-8827	4		RESISTOR 1M 1% 125W F TC=0±100	03292	CT4
A53R44	0698-0084	9		RESISTOR 2 15k 1% 125W F TC=0±100	03292	C4-1/8-T0-2151-F
A53R45	0698-8827	4		RESISTOR 1M 1% 125W F TC=0±100	03292	CT4
A53R46	0757-0442	9		RESISTOR 10k 1% 125W F TC=0±100	24546	C4-1/8-T0-1002-F
A53R47	0757-0465	6	1	RESISTOR 100k 1% 125W F TC=0±100	24546	C4-1/8-T0-1003-F
A53R48	0757-0442	9		RESISTOR 10k 1% 125W F TC=0±100	24546	C4-1/8-T0-1002-F
A53R49	0757-0442	9		RESISTOR 10k 1% 125W F TC=0±100	24546	C4-1/8-T0-1002-F
A53R50	0698-3154	0	1	RESISTOR 4 22k 1% 125W F TC=0±100	24546	C4-1/8-T0-4221-F
A53R51	0757-0442	9		RESISTOR 10k 1% 125W F TC=0±100	24546	C4-1/8-T0-1002-F
A53R52	0757-0280	3		RESISTOR 1k 1% 125W F TC=0±100	24546	C4-1/8-T0-1001-F
A53R53	0757-0280	3		RESISTOR 1k 1% 125W F TC=0±100	24546	C4-1/8-T0-1001-F
A53R54	0757-0280	3		RESISTOR 1k 1% 125W F TC=0±100	24546	C4-1/8-T0-1001-F
A53R55	0757-0274	5	2	RESISTOR 1 21k 1% 125W F TC=0±100	03292	CT4-1/8-T0-1211-F
A53R56	0757-0274	5	2	RESISTOR 1 21k 1% 125W F TC=0±100	03292	CT4-1/8-T0-1211-F
A53TP1	0360-0535	0	6	TERMINAL TEST POINT PCB	00000	ORDER BY DESCRIPTION
A53TP2	0360-0535	0		TERMINAL TEST POINT PCB	00000	ORDER BY DESCRIPTION
A53TP3	0360-0535	0		TERMINAL TEST POINT PCB	00000	ORDER BY DESCRIPTION
A53TP4	0360-0535	0		TERMINAL TEST POINT PCB	00000	ORDER BY DESCRIPTION
A53TP5	0360-0535	0		TERMINAL TEST POINT PCB	00000	ORDER BY DESCRIPTION
A53TP6	0360-0535	0		TERMINAL TEST POINT PCB	00000	ORDER BY DESCRIPTION
A53U1	1826-0523	5	1	IC 337 V RGLTR T0-3	27014	LM337K
A53U2	1826-0138	8	1	IC COMPARATOR GP QUAD 14-DIP-P PKG	01295	LM339N
A53U3	1820-0223	0	2	IC OP AMP GP T0-99 PKG	3L585	CA301AT
A53U4	1820-0223	0		IC OP AMP GP T0-99 PKG	3L585	CA301AT
A53VR1	1902-3171	7	1	DIODE-ZNR 11V 5% DO-35 PD= 4W TC= + 062%	28480	1902-3171
A53VR2	1902-0049	2	1	DIODE-ZNR 6 19V 5% DO-35 PD= 4W	28480	1902-0049
A53VR3	1902-3330	0	1	DIODE-ZNR 44.2v 2% DO-35 PD= 4W	28480	1902-3330
A53VR4	1902-0025	4	1	DIODE-ZNR 10V 5% DO-35 PD= 4W TC= + 06%	28480	1902-0025
A53VR5	1902-3083	0	1	DIODE-ZNR 4 64V 2% DO-35 PD= 4W	28480	1902-3083
A53VR6	1902-3291	2	1	DIODE-ZNR 31 6V 2% DO-35 PD= 4W	28480	1902-3291
A53VR7	1902-0041	4	1	DIODE-ZNR 5 11V 5% DO-35 PD= 4W	28480	1902-0041
A53VR8	1902-0244	9	1	DIODE-ZNR 30V 5% PD=1W IR=5UA	28480	1902-0244

A56 – 15V Regulator Component-Level Troubleshooting

Table A56-6. A56 – 15V Regulator Replaceable Parts

Reference Designation	HP Part Number	C D	Qty	Description	Mfr Code	Mfr Part Number
A56	08340-60029	2	1	- 15V REGULATOR ASSEMBLY	28480	08340-60029
A56C1	0180-2505	6	1	CAPACITOR-FXD 10UF ± 10% 75VDC TA	56289	150D105X9075B2
A56C2	0180-2129	0	1	CAPACITOR-FXD 10UF ± 10% 50VDC TA	56289	150D106X9050R2
A56C3	0180-0291	3	1	CAPACITOR-FXD 10UF ± 10% 35VDC TA	56289	150D105X9035A2
A56CR1	1901-0033	2	1	DIODE-GEN PRP 180V .00MA DO-7	28480	1901-0033
A56CR2	1901-0662	3	2	DIODE-PWR RECT 100V 6A 04713 MR751		
A56CR3	1901-0662	3		DIODE-PWR RECT 100V 6A 04713 MR751		
A56DS1	1990-1147	8	1	LED-LAMP LUM-INT=1MCD IF=20MA-MAX BVR=5V	28480	1990-1147
A56E1	1251-2313	6	2	CONNECTOR-SGL CONT SKT 04-IN-BSC-SZ RND	28480	1251-2313
A56E2	1251-2313	6		CONNECTOR-SGL CONT SKT 04-IN-BSC-SZ RND	28480	1251-2313
A56F1	2110-0047	2	1	FUSE 1A 125V 25X 27	71400	GMW-1
A56MP1	5040-6849	8	1	EXTRACTOR, P C BOARD	28480	5040-6849
A56MP2	5000-9043	6	1	PIN P C BOARD EXTRACTOR	28480	5000-9043
A56MP3	08340-00030	9	1	HEAT SINK	28480	08340-00030
A56MP4	0590-0526	6	1	THREADED INSERT-NUT 4-40 065-IN-LG SST	28480	0590-0526
A56MP5	2200-0105	4	1	SCREW-MACH 4-40 312-IN-LG PAN-HD-POZI	00000	ORDER BY DESCRIPTION
A56Q1	1884-0244	9	1	THYRISTOR-SCR VRRM=400	3L585	S2600D
A56Q2	1855-0414	4	1	TRANSISTOR J-FET 2N4393 N-CHAN D-MODE	04713	2N4393
A56R1	0811-1084	3	2	RESISTOR 22 5% 3W PW TC=0 ± 30	28480	0811-1084
A56R2	0698-3444	1	1	RESISTOR 316 1% 125W F TC=0 ± 100	24546	C4-1/8-T0-316R-F
A56R3	0757-0346	2	1	RESISTOR 10 1% 125W F TC=0 ± 100	24546	C4-1/8-T0-10R0-F
A56R4	0698-3132	4	1	RESISTOR 261 1% 125W F TC=0 ± 100	24546	C4-1/8-T0-2610-F
A56R5	0757-0280	3	1	RESISTOR 1K 1% 125W F TC=0 ± 100	24546	C4-1/8-T0-1001-F
A56R6	0811-1084	3		RESISTOR 22 5% 3W PW TC=0 ± 30	28480	0811-1084
A56R7	0757-0403	2	1	RESISTOR 121 1% 125W F TC=0 ± 100	24546	C4-1/8-T0-121R-F
A56TP1	0360-0535	0	2	TERMINAL TEST POINT PCB	00000	ORDER BY DESCRIPTION
A56TP2	0360-0535	0		TERMINAL TEST POINT PCB	00000	ORDER BY DESCRIPTION
A56U1	1826-0523	5	1	IC 337 V RGLTR TO-3	27014	LM337K
A56VR1	1902-3224	1	1	DIODE-ZNR 17 8V 5% DO-35 PD= 4W	28480	1902-3224
A56VR2	1902-3182	0	1	DIODE-ZNR 12 1V 5% DO-35 PD= 4W	28480	1902-3182
A56VR3	1902-0025	4	1	DIODE-ZNR 10V 5% DO-35 PD= 4W TC= + 06%	28480	1902-0025
A56VR4	1902-3197	7	1	DIODE-ZNR 13 7V 2% DO-35 PD= 4W	28480	1902-3197

Major Assemblies and Components Location – Chassis Parts Component-Level Service J

CONTENTS

MAJOR ASSEMBLIES AND COMPONENTS LOCATION

Figure J-1. Front and Rear Panels	J-1
Figure J-2. Front Panel Assemblies	J-2
Figure J-3. HP 8340B Top View	J-3
Figure J-4. HP 8340B – Bottom View	J-4
Table J-1. Miscellaneous Electrical Replaceable Parts	J-7
Figure J-5. Miscellaneous Mechanical & Chassis Parts	J-11
Table J-2. Miscellaneous Mechanical & Chassis Replaceable Parts	J-17

OPTION CONFIGURATIONS

Table J-3. HP 8340B Option Configurations	J-21
---	------

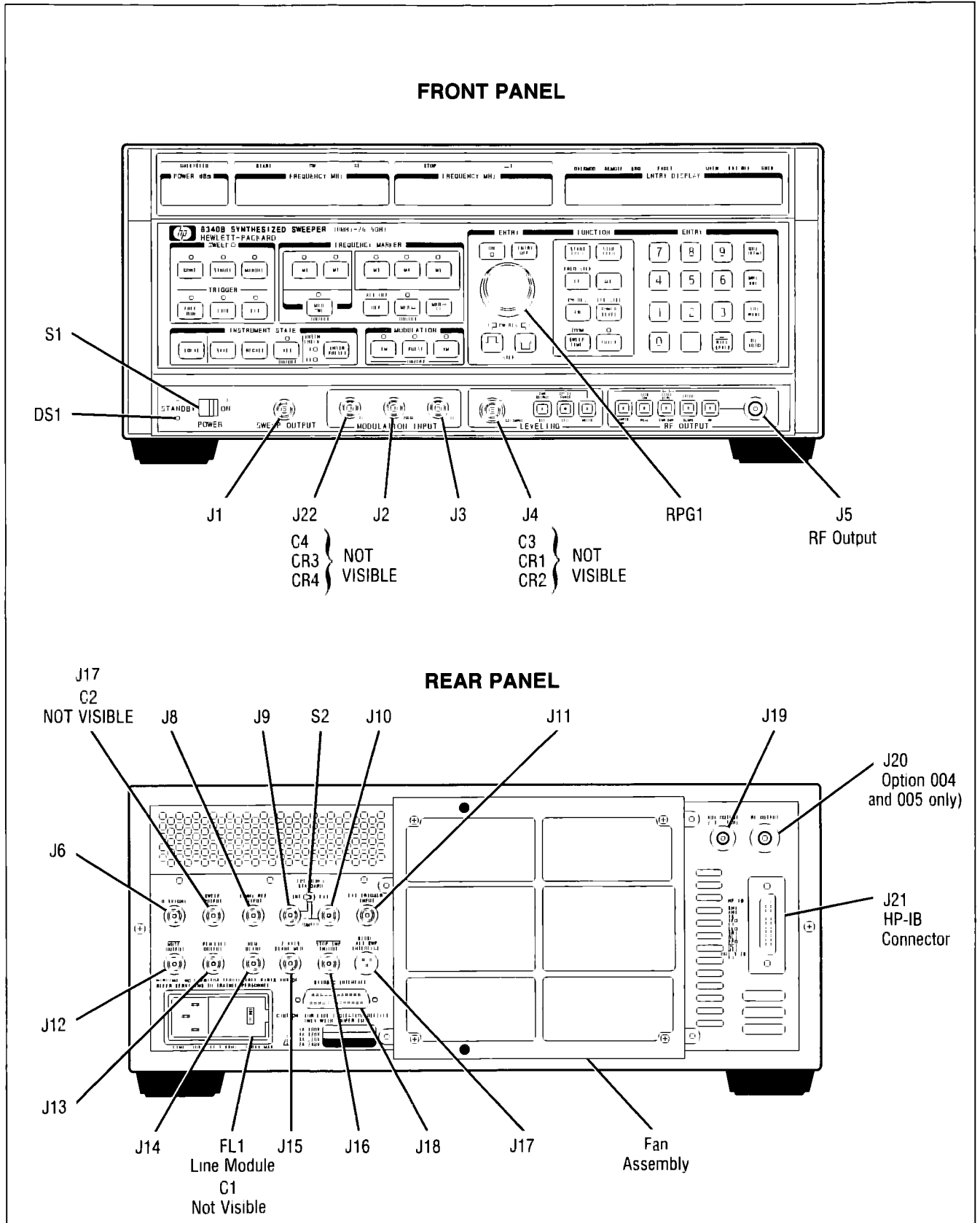

Figure J-1. Front and Rear Panels

Major Assemblies and Components Location

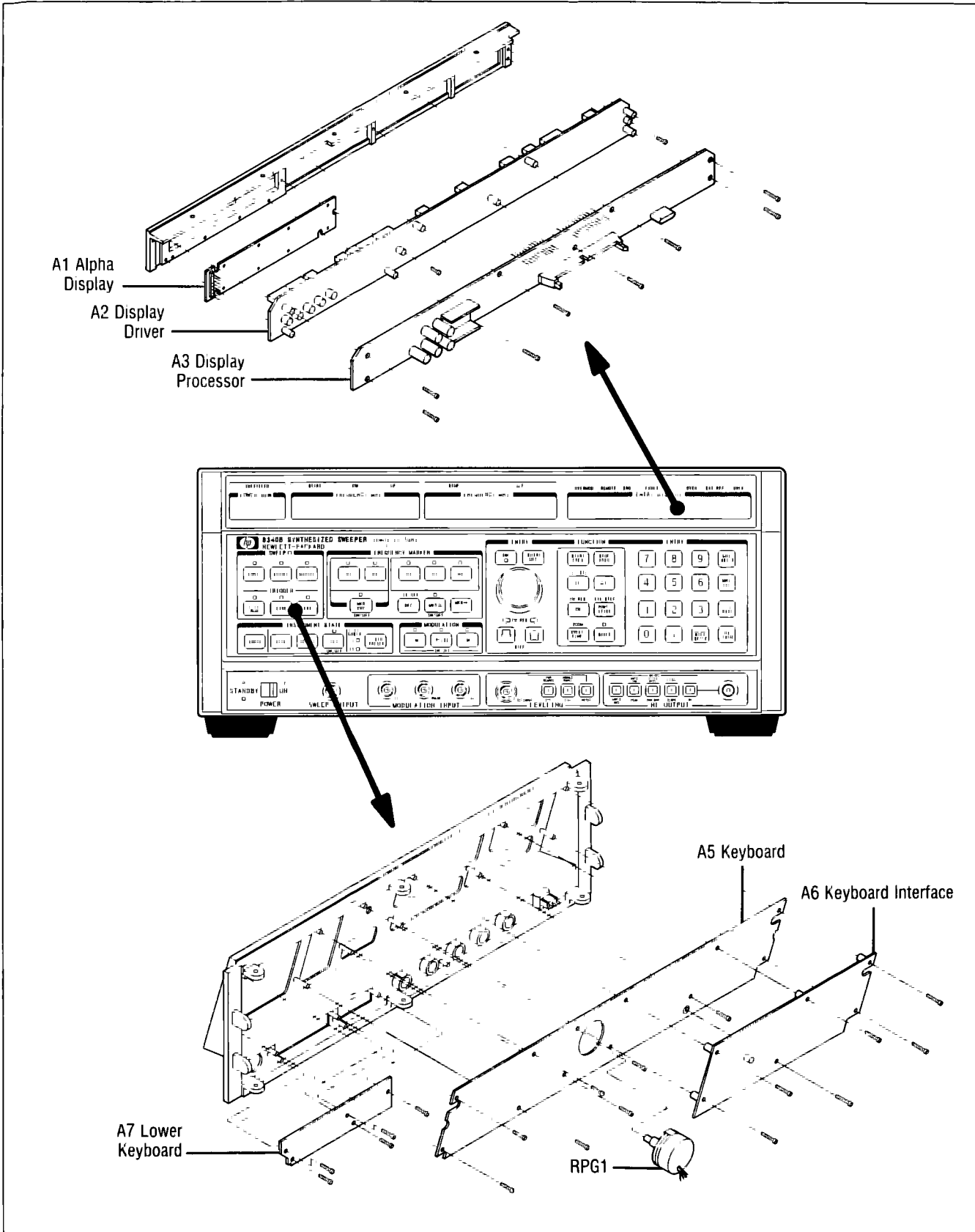

Figure J-2. Front Panel Assemblies

Major Assemblies and Components Location

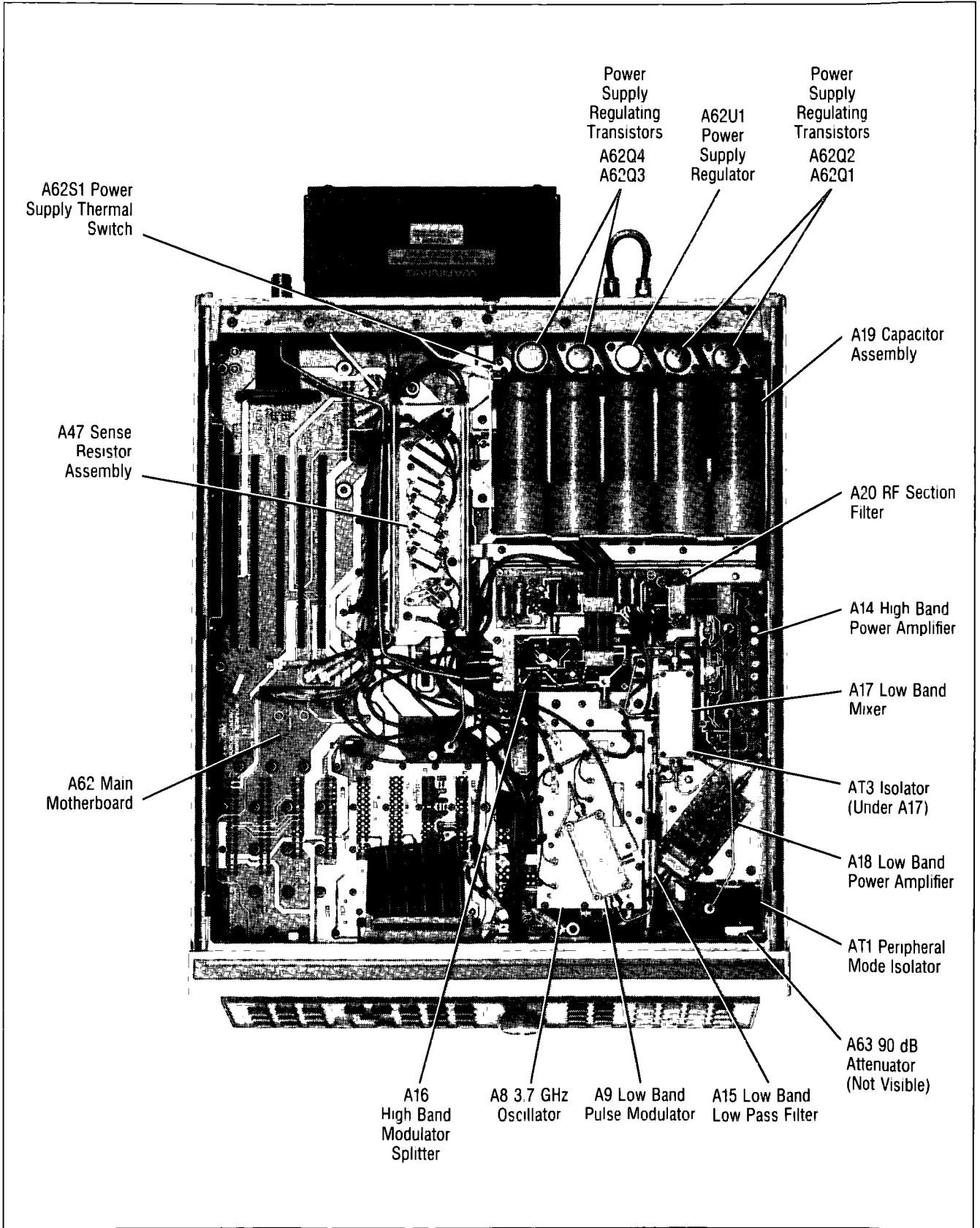

Figure J-3. HP 8340B Top View

Major Assemblies and Components Location

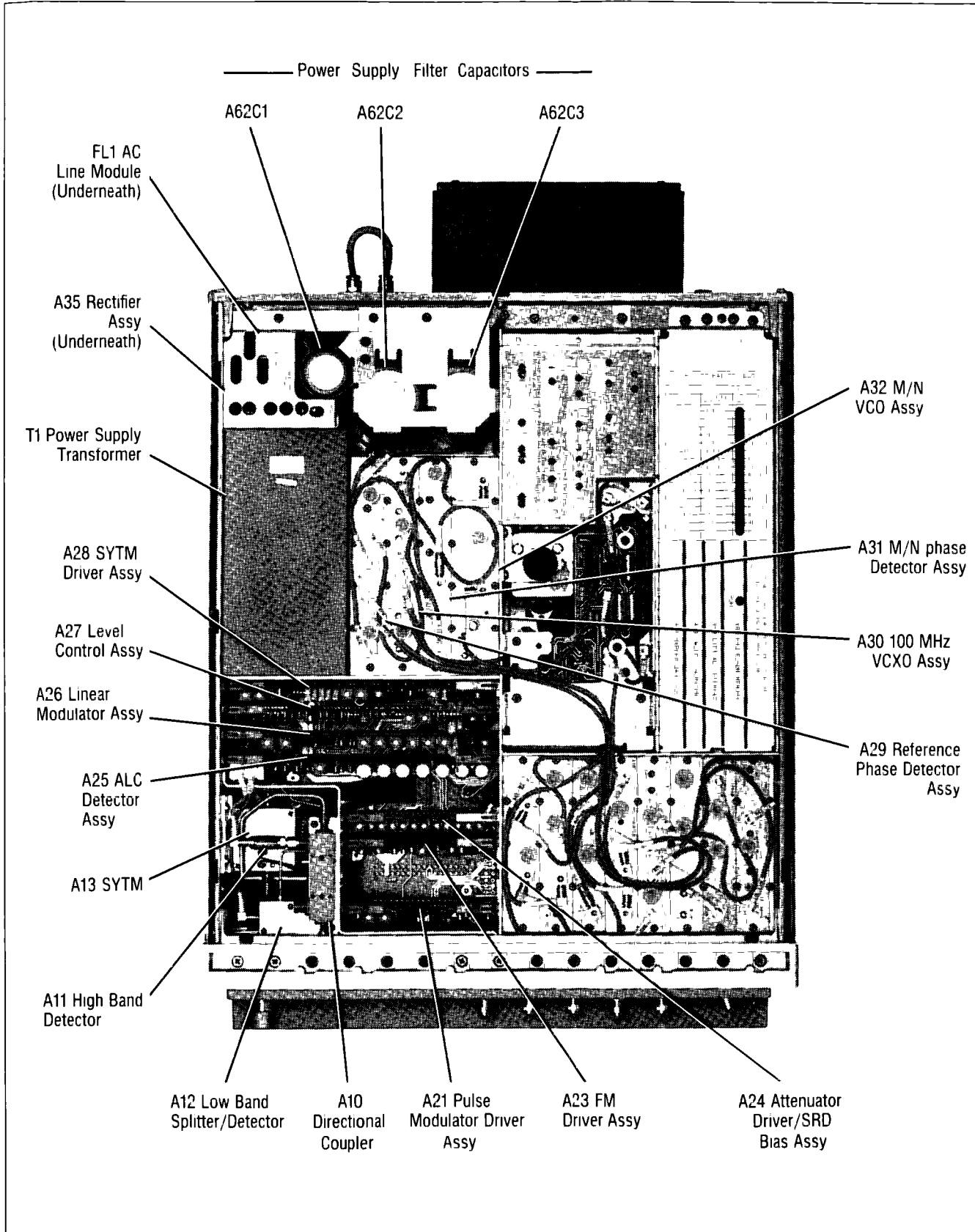

Figure J-4. HP 8340B - Bottom View (1 of 2)

Major Assemblies and Components Location

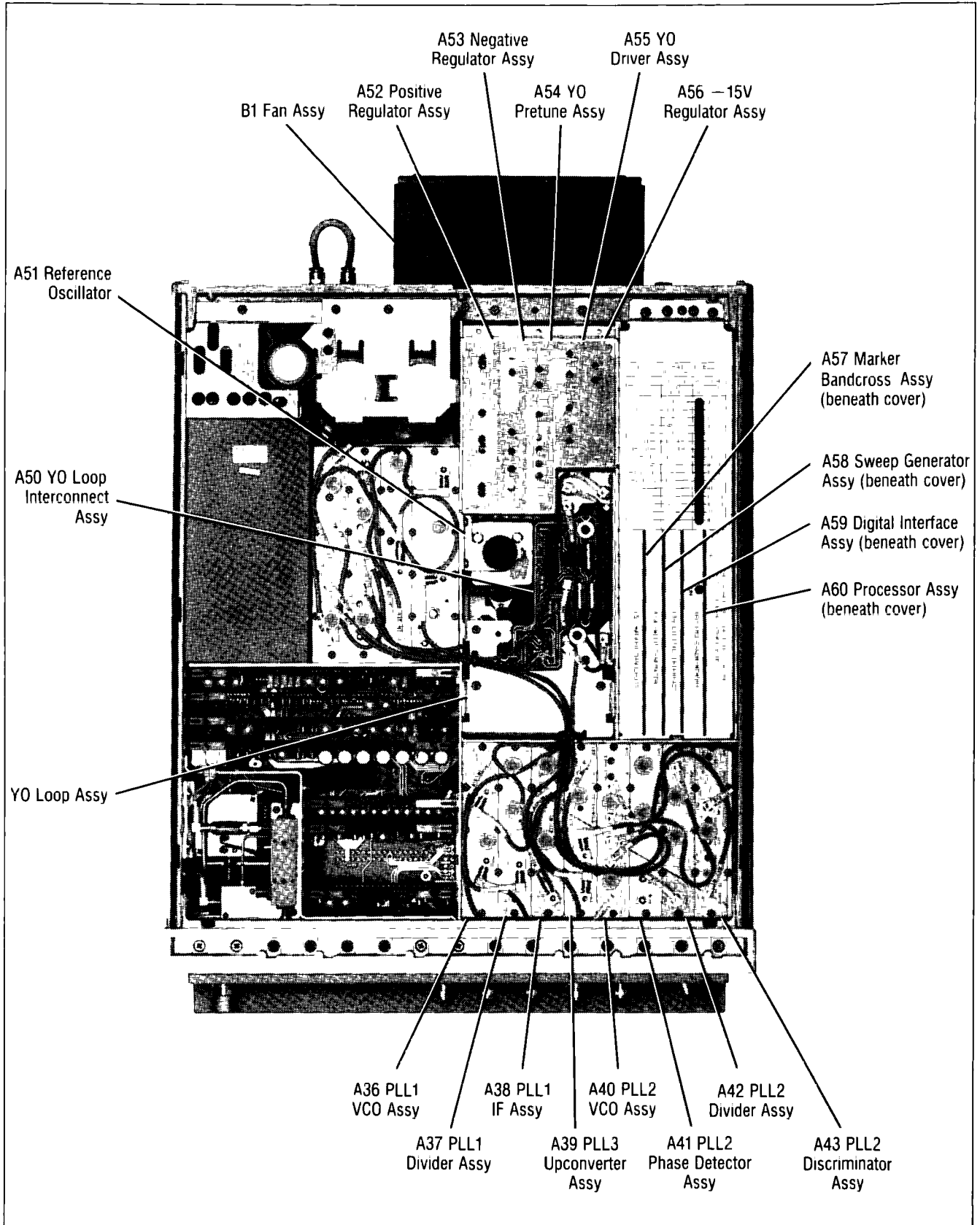

Figure J-4. HP 8340B - Bottom View (2 of 2)

Major Assemblies and Components Location

Table J-1. Miscellaneous Electrical Replaceable Parts

Reference Designation	HP Part Number	C D	Qty	Description	Mfr Code	Mfr Part Number
MISCELLANEOUS ELECTRICAL PARTS						
A63	08340-60175	9	1	90 DB PROGRAMMABLE ATTENUATOR	28480	08340-60175
AT1	0960-0638	8	1	PERIPHERAL MODE ISOLATOR	28480	0960-0638
AT3	0960-0701	4	1	3.7 GHz ISOLATOR	28480	0960-0701
B1	08340-60291	0	1	FAN ASSEMBLY Includes B1W1 and the following parts	28480	08340-60291
	0360-0535	0	2	TERMINAL TEST POINT PCB	00000	ORDER BY DESCRIPTION
	0890-0029	0	1	TUBING-HS 187-D/ 093-RCVD 02-WALL	28480	0890-0029
	0890-0983	5	1	TUBING-HS 125-D/ 062-RCVD 02-WALL	28480	0890-0983
	1251-4223	1	2	CONNECTOR- CONT F 025	28480	1251-4223
	1251-6796	7	1	CONNECTOR HOUSING- 3 FEMALE IR	28480	1251-6796
	1400-0249	0	1	CABLE TIE 062- 625-DIA 091-WD NYL	06383	PLT1M-8
	1520-0230	3	4	SHOCK MOUNT 27-EFF-HGT 2-LB-LOAD-CAP	28480	1520-0230
	2190-0017	4	2	WASHER-LK HLCL NO. 8 168-IN-ID	28480	2190-0017
	2200-0770	9	10	SCREW-MACH 4-40 188-IN-LG 100 DEG	00000	ORDER BY DESCRIPTION
	2360-0119	8	4	SCREW-MACH 6-32 438-IN-LG PAN-HD-POZI	00000	ORDER BY DESCRIPTION
	2360-0196	1	4	SCREW-MACH 6-32 375-IN-LG 100 DEG	00000	ORDER BY DESCRIPTION
	2510-0135	7	2	SCREW-MACH 8-32 2 25-IN-LG PAN-HD-POZI	00000	ORDER BY DESCRIPTION
	2680-0137	8	1	SCREW-MACH 10-32 188-IN-LG PAN-HD-SLT	00000	ORDER BY DESCRIPTION
	3160-0371	1	1	FAN-TBAX 180-CFM 115V 50/60-HZ	28480	3160-0371
	8150-0011	0	1	WIRE 22AWG G 300V PVC 7X30 105C	28480	8150-0011
	8150-0447	6	1	WIRE 24AWG BK 300V PVC 7X32 80C	28480	8150-0447
	08340-00012	7	1	HOUSING FAN (TOP)	28480	08340-00012
	08340-00013	8	1	HOUSING FAN (BOTTOM)	28480	08340-00013
	08340-00097	8	1	HOUSING FAN (GRILLE)	28480	08340-00097
	08340-00016	1	1	BASE PLATE	28480	08340-00016
	08340-00017	2	1	GRILL AIR FILTER	28480	08340-00017
	08340-00018	3	1	FILTER-AIR	28480	08340-00018
	85660-20092	4	4	SNUBBER-SHOCK MOUNT	28480	85660-20092
C1	0160-4065	5	1	CAPACITOR-FXD 1UF ±20% 250VAC (RMS) (On FL1, line module)	28480	0160-4065
C2	0160-4819	7	1	CAPACITOR-FXD 2200PF ±5% 100VDC CER (On J7, sweep output)	28480	0160-4819
C3	0160-4832	4	2	CAPACITOR-FXD 01UF ±10% 100VDC CER (On J4, external input)	28480	0160-4832
C4	0160-4832	4	1	CAPACITOR-FXD 01UF ±10% 100VDC CER (On J22, FM input)	28480	0160-4832
CR1	1901-0179	7	4	DIODE-SWITCHING 15V 50MA 750PS DO-7 (On J4, external input)	28480	1901-0179
CR2	1901-0179	7	1	DIODE-SWITCHING 15V 50MA 750PS DO-7 (On J4, external input)	28480	1901-0179
CR3	1901-0179	7	1	DIODE-SWITCHING 15V 50MA 750PS DO-7 (On J22, FM input)	28480	1901-0179
CR4	1901-0179	7	1	DIODE-SWITCHING 15V 50MA 750PS DO-7 (On J22, FM input)	28480	1901-0179
DS1	1990-0858	6	1	LED-LAMP LUM-INT= 150UCD IF=25MA MAX (On front panel Standby indicator)	28480	1990-0858
	1450-0615	9	1	LAMPHOLDER	28480	1450-0615
	08340-40002	9	1	LED MOUNT	28480	08340-40002
F1	2110-0002	9	1	FUSE 2A 250V NTD 1 25X 25 UL (For 240V operation)	75915	312002
F1	2110-0003	0	1	FUSE 3A 250V NTD 1 25X 25 UL (For 200V operation)	75915	312003
F1	2110-0010	9	1	FUSE 5A 250V NTD 1 25X 25 UL (For 100V operation)	75915	312005
F1	2110-0055	2	1	FUSE 4A 250V NTD 1 25X 25 UL (For 120V operation)	75915	312004
FL1	08340-60257	8	1	LINE MODULE-FILTERED REPLACEMENT KIT (Includes 2 metal retainers)	28480	08340-60257
J1				P/O J1W1		
J1W1	08340-60071	4	1	CABLE ASSY-COAX (SWP OUT)	28480	08340-60071
	0590-1251	6	4	NUT-SPCLY 15/32-32-THD 1-IN-THK 562-WD	00000	ORDER BY DESCRIPTION
	1250-0870	4	3	CONNECTOR-RF BNC FEM SGL-HOLE-RR 50-OHM	28480	1250-0870
J2				P/O J2W1		
J2W1	08340-60066	7	1	CABLE ASSY-COAX (PULSE)	28480	08340-60066
	0590-1251	6	1	NUT-SPCLY 15/32-32-THD 1-IN-THK 562-WD	00000	ORDER BY DESCRIPTION
	1250-0870	4	1	CONNECTOR-RF BNC FEM SGL-HOLE-RR 50-OHM	28480	1250-0870

Major Assemblies and Components Location

Table J-1 Miscellaneous Electrical Replaceable Parts

Reference Designation	HP Part Number	C D	Qty	Description	Mfr Code	Mfr Part Number
J3 J3W1	08340-60069 0590-1251 1250-0870	0 6 4	1	P/O J3W1 CABLE ASSY-COAX (AM) NUT-SPCLY 15/32-32-THD 1-IN-THK 562-WD CONNECTOR-RF BNC FEM SGL-HOLE-RR 50-OHM	28480 00000 28480	08340-60069 ORDER BY DESCRIPTION 1250-0870
J4 J4W1	08340-60068 00310-48801 0590-1251 0360-1158 1250-1091	9 0 6 5 3	1 2	P/O J4W1 CABLE ASSY-COAX (EXT INPUT) WASHER-SHOULDERED NUT-SPCLY 15/32-32-THD 1-IN-THK 562-WD LUG CONNECTOR-RF BNC FEM SGL-HOLE-RR 50-OHM	28480 28480 00000 28480 28480	08340-60068 00310-48801 ORDER BY DESCRIPTION 0360-1158 1250-1091
J5	5061-5316	6	1	RF OUTPUT CONNECTOR ASSEMBLY	28480	5061-1100
J6	1250-0083 0360-1632 2950-0001	1 0 8	8 4 2	CONNECTOR-RF BNC FEM SGL-HOLE-FR 50-OHM TERMINAL-SLDR LUG LK-MTG FOR-#3/8-SCR NUT-HEX-DBL-CHAM 3/8-32-THD 094-IN-THK	28480 28480 00000	1250-0083 0360-1632 ORDER BY DESCRIPTION
J7	1250-0083 0360-1632 2950-0001	1 0 8		CONNECTOR-RF BNC FEM SGL-HOLE-FR 50-OHM TERMINAL-SLDR LUG LK-MTG FOR-#3/8-SCR NUT-HEX-DBL-CHAM 3/8-32-THD 094-IN-THK	28480 28480 00000	1250-0083 0360-1632 ORDER BY DESCRIPTION
J7W1	08340-60070	3	1	CABLE ASSY-COAX (A62J8 TO R P J7)	28480	08340-60070
J8	1250-0102 2190-0068 2950-0054	5 5 1	3 3 3	CONNECTOR-RF BNC FEM SGL-HOLE-FR 50-OHM WASHER-LK INTL T 1/2 IN 505-IN-ID NUT-HEX-DBL-CHAM 1/2-28-THD 125-IN-THK	28480 28480 00000	1250-0102 2190-0068 ORDER BY DESCRIPTION
J8W1	08340-60086	1	1	CABLE ASSY-COAX (A29J5 TO R P J8)	28480	08340-60086
J9	1250-0102 2190-0068 2950-0054	5 5 1		CONNECTOR-RF BNC FEM SGL-HOLE-FR 50-OHM WASHER-LK INTL T 1/2 IN 505-IN-ID NUT-HEX-DBL-CHAM 1/2-28-THD 125-IN-THK	28480 28480 00000	1250-0102 2190-0068 ORDER BY DESCRIPTION
J9W1	08340-60089	4	1	CABLE ASSY-COAX (A51J1 TO R P J9)	28480	08340-60089
J10	1250-0102 2190-0068 2950-0054	5 5 1		CONNECTOR-RF BNC FEM SGL-HOLE-FR 50-OHM WASHER-LK INTL T 1/2 IN 505-IN-ID NUT-HEX-DBL-CHAM 1/2-28-THD 125-IN-THK	28480 28480 00000	1250-0102 2190-0068 ORDER BY DESCRIPTION
J10W1	08340-60085	0	1	CABLE ASSY-COAX (A29J1 TO R P J10)	28480	08340-60085
J11	1250-0083 2190-0016	1 3	4	CONNECTOR-RF BNC FEM SGL-HOLE-FR 50-OHM WASHER-LK INTL T 3/8 IN 377-IN-ID	28480 28480	1250-0083 2190-0016
J12	1250-0083 2190-0016	1 3		CONNECTOR-RF BNC FEM SGL-HOLE-FR 50-OHM WASHER-LK INTL T 3/8 IN 377-IN-ID	28480 28480	1250-0083 2190-0016
J13	1250-0083 0360-1632	1 0		CONNECTOR-RF BNC FEM SGL-HOLE-FR 50-OHM TERMINAL-SLDR LUG LK-MTG FOR-#3/8-SCR	28480 28480	1250-0083 0360-1632
J14	1250-0083 2190-0016	1 3		CONNECTOR-RF BNC FEM SGL-HOLE-FR 50-OHM WASHER-LK INTL T 3/8 IN 377-IN-ID	28480 28480	1250-0083 2190-0016
J15	1250-0083 2190-0016	1 3		CONNECTOR-RF BNC FEM SGL-HOLE-FR 50-OHM WASHER-LK INTL T 3/8 IN 377-IN-ID	28480 28480	1250-0083 2190-0016
J16	1250-0083 0360-1632	1 0		CONNECTOR-RF BNC FEM SGL-HOLE-FR 50-OHM TERMINAL-SLDR LUG LK-MTG FOR-#3/8-SCR	28480 28480	1250-0083 0360-1632
J17	1251-6781	0	1	CONNECTOR 3-PIN M CIRC AUDIO (Includes mounting hardware)	28480	1251-6781
J18	1251-0064 1251-2942	0 7	1 2	CONNECTOR 25-PIN F D SERIES MOUNTING HARDWARE KIT	28480 28480	1251-0064 1251-2942
J19	08340-60127 2190-0104 2950-0132	1 0 6	1 1 1	CONNECTOR-TYPE N (R P AUX OUT) WASHER-LK INTL T 7/16 IN 439-IN-ID NUT-HEX-DBL-CHAM 7/16-28-THD 094-IN-THK	28480 28480 00000	08340-60127 2190-0104 ORDER BY DESCRIPTION
J20				REFER TO OPTION 004 AND 005 LISTINGS		
J21 J21W1	8120-3653	9	1	P/O J21W1 CABLE ASSY-RIBBON (HP-IB) (Includes J21 and mounting hardware)	28480	8120-3653
J22	1250-1091 0360-1158 00310-48801 0590-1251	3 5 0 6	1 1 2 1	BODY-RF CONNECTOR BNC FEMALE, STRAIGHT TERMINAL-SLDR LUG PL-MTG 062-HOLE-DID WASHER SHOULDERED, INSULATING NUT-SPCLY 15/32-32-THD 1-IN-THK 562-WD	03316 05313 00000 00000	28J5124-1 5413-21 ORDER BY DESCRIPTION ORDER BY DESCRIPTION
RPG1	08340-60197	5	1	ROTARY PULSE GENERATOR REPLACEMENT KIT (Includes locking tangs, connector housing, nut and washer)	28480	08340-60197
S1 S2	3101-2193 3101-0163	5 5	1 1	SWITCH-TGL SUBMIN SPDT 2A 250VAC FREQUENCY STANDARD SWITCH KIT (Includes mounting hardware)	28480 28480	3101-2193 3101-0163

Major Assemblies and Components Location

Table J-1. Miscellaneous Electrical Replaceable Parts

Reference Designation	HP Part Number	C	D	Qty	Description	Mfr Code	Mfr Part Number
T1	9100-4133	1	1	1	TRANSFORMER	28480	9100-4133
	08340-60124	8			COMPLETE TRANSFORMER ASSEMBLY (Includes wiring harness and attached lugs) Individual transformer wire solder lugs can be ordered below.	28480	08340-60124
	0360-0037	7	6		TERMINAL-SLDR LUG PL-MTG FOR-#6-SCR	28480	0360-0037
	0360-0042	4	2		TERMINAL-SLDR LUG PL-MTG FOR-#6-SCR	28480	0360-0042
	0360-0043	5	1		TERMINAL-SLDR LUG PL-MTG FOR-#6-SCR	28480	0360-0043
W1	08340-60062	3	1	1	CABLE ASSY-RIBBON A7J1 TO A6J1	28480	08340-60062
W2	NONE			1	WIRE ASSY-RF MODULE(GND) TO FRONT PANEL		
W3	08340-20198	2	1	1	CABLE ASSY-RIGID COAX W51 TO A16J2	28480	08340-20198
W4	08340-20116	4	1	1	CABLE ASSY-RIGID COAX A16J1 TO J19	28480	08340-20116
W5	08340-20241	6	1	1	CABLE ASSY-RIGID COAX A17J2 TO A16J7	28480	08340-20241
W6	08340-20108	4	1	1	CABLE ASSY-RIGID COAX A16J6 TO A14J1	28480	08340-20108
W7	08340-20111	8	1	1	CABLE ASSY-RIGID COAX A14J1 TO AT1J1	28480	08340-20110
W8	08340-20111	9	1	1	CABLE ASSY-RIGID COAX AT1J2 TO A13J1	28480	08340-20111
W9	08340-20114	2	1	1	CABLE ASSY-RIGID COAX A8A2J1 TO A9J1	28480	08340-20114
W10	08340-20268	7	1	1	CABLE ASSY-RIGID COAX A9J2 TO A15J1	28480	08340-20268
W11					NOT ASSIGNED		
W12	08340-20107	3	1	1	CABLE ASSY-RIGID COAX A17J3 TO A18J1	28480	08340-20107
W13	08340-20223	4	1	1	CABLE ASSY-RIGID COAX A18J2 TO A12J1	28480	08340-20223
W14	08340-20224	5	1	1	CABLE ASSY-RIGID COAX A12J2 TO A13J2	28480	08340-20224
W15					NOT ASSIGNED		
W16	08340-20221	2	1	1	CABLE ASSY-RIGID COAX A13J3 TO A10J1	28480	08340-20221
W17					NOT ASSIGNED		
W18	08340-20119	7	1	1	CABLE ASSY-RIGID COAX A10J3 TO A63J1(STD)	28480	08340-20119
W19	08340-20117	5	1	1	CABLE ASSY-RIGID COAX A63J2 TO J5 (STD)	28480	08340-20117
W20	08340-20122	2	1	1	CABLE ASSY-RIGID COAX A63J2 TO J20 (004)	28480	08340-20122
W21	08340-20121	1	1	1	CABLE ASSY-RIGID COAX A10J3 TO J5 (001)	28480	08340-20121
W22	08340-20120	0	1	1	CABLE ASSY-RIGID COAX A10J3 TO J20 (005)	28480	08340-20120
W23	08340-60118	0	1	1	CABLE ASSY-COAX A30J3 TO A8A1J1	28480	08340-60118
W24	08340-60117	9	1	1	CABLE ASSY-COAX A62J14 TO A8A1J2	28480	08340-60117
W25	08340-60119	1	1	1	CABLE ASSY-COAX A62J10 TO A9J3	28480	08340-60119
W26	08340-60115	7	1	1	CABLE ASSY-COAX A12J3 TO A25J2	28480	08340-60115
W27	08340-60114	6	1	1	CABLE ASSY-COAX A11J2 TO A25J1	28480	08340-60114
W28	08340-60126	0	1	1	CABLE ASSY-COAX A62J13 TO A16J3	28480	08340-60126
W29	08340-60125	9	1	1	CABLE ASSY-COAX A62J25 TO A16J4	28480	08340-60125
W30	08340-60080	5	1	1	CABLE ASSY-COAX A16A1J2 TO A16J5	28480	08340-60080
W31	08340-60060	1	1	1	CABLE ASSY-RIBBON A62J19 TO A20J1/A16A1	28480	08340-60060
W32	08340-60058	7	1	1	CABLE ASSY-RIBBON A20J2 TO A14A1J1	28480	08340-60058
W33	08340-60061	2	1	1	CABLE ASSY-RIBBON A62J18 TO A13A1J1	28480	08340-60061
W34	08340-60116	8	1	1	CABLE ASSY-COAX A29J4 TO A37J1	28480	08340-60116
W35	08340-60081	6	1	1	CABLE ASSY-COAX A39J2 TO A30J2	28480	08340-60081
W36	08340-60073	6	1	1	CABLE ASSY-COAX A29J3 TO A42J1	28480	08340-60073
W37	08340-60075	8	1	1	CABLE ASSY-COAX A49J1 TO A44J1	28480	08340-60075
W38	08340-60074	7	1	1	CABLE ASSY-COAX A49J2 TO A62J6	28480	08340-60074
W39	08340-60078	1	1	1	CABLE ASSY-COAX A36J1 TO A49J3	28480	08340-60078
W40	08340-60072	5	1	1	CABLE ASSY-COAX A48J1 TO A49J4	28480	08340-60072
W41	08340-60084	9	1	1	CABLE ASSY-COAX A33J2 TO A48J2	28480	08340-60084
W42	08340-20197	1	1	1	CABLE ASSY-RIGID COAX A44J2 TO A45J1	28480	08340-20197
W43	08340-20196	0	1	1	CABLE ASSY-RIGID COAX AT2J2 TO A46J1	28480	08340-20196
W44	08340-20101	7	1	1	CABLE ASSY-RIGID COAX A46J2 TO A48U1J1	28480	08340-20101
W45	NONE	1			WIRE ASSY-STAR GND TO LUG BY A62J29		
W46	08340-60184	0	1	1	WIRE ASSY (Includes W47 and J7W1)	28480	08340-60184
W47	08340-60082	7	1	1	CABLE ASSY-COAX A62J27 TO A62J4	28480	08340-60082
W48	08340-60079	2	1	1	CABLE ASSY-COAX A62J5 TO A62J11	28480	08340-60079
W49	08340-60088	3	1	1	CABLE ASSY-COAX J9 TO J10	28480	08340-60088
W50	08340-60065	6	1	1	WIRE ASSY- A6J4 TO POWER SWITCH	28480	08340-60065
W51	08340-20195	9	1	1	CABLE ASSY-RIGID COAX A45J3 TO W3	28480	08340-20195
W52	08340-20233	6	1	1	CABLE ASSY-RIGID COAX A15J2 TO AT3J1	28480	08340-20233
W53	08340-20227	8	1	1	CABLE ASSY-RIGID COAX AT3J2 TO A17J1	28480	08340-20227

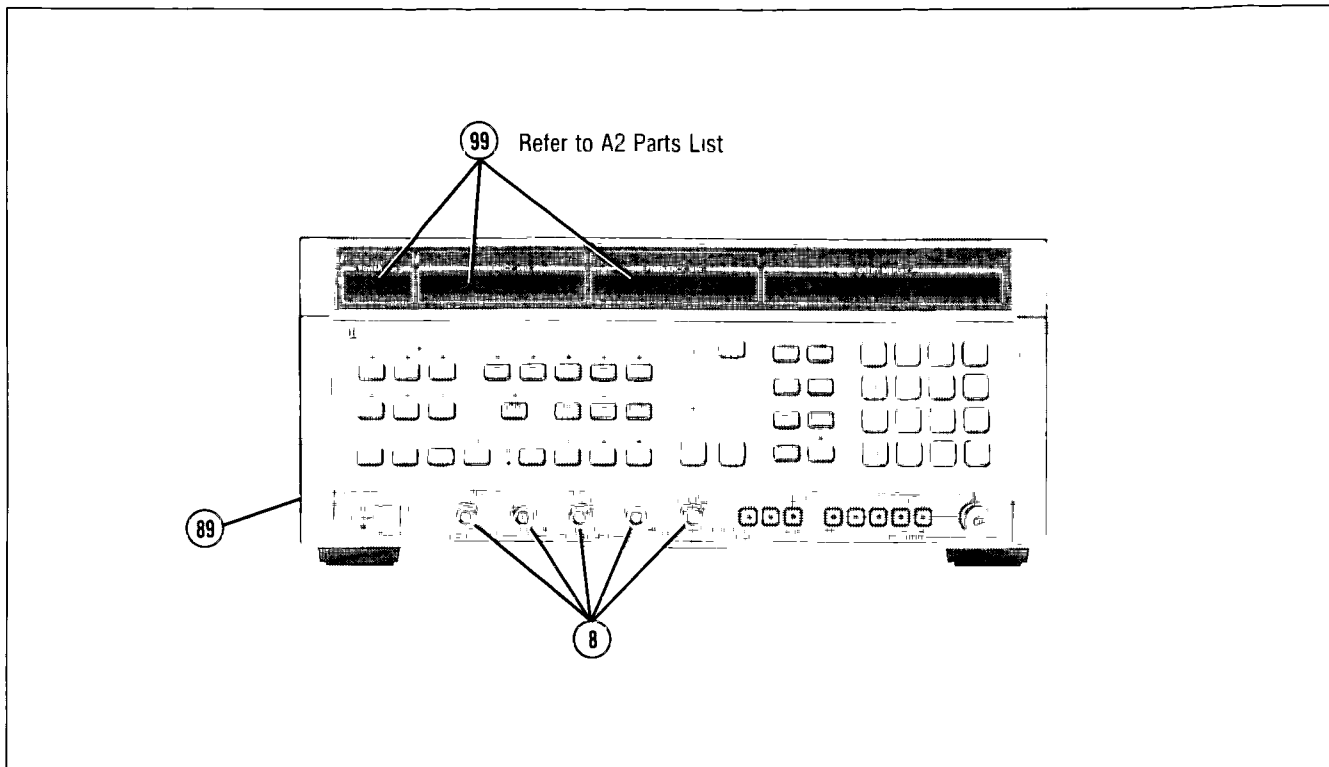

Figure J-5. Miscellaneous Mechanical & Chassis Parts (1 of 6)

Miscellaneous Mechanical and Chassis Parts

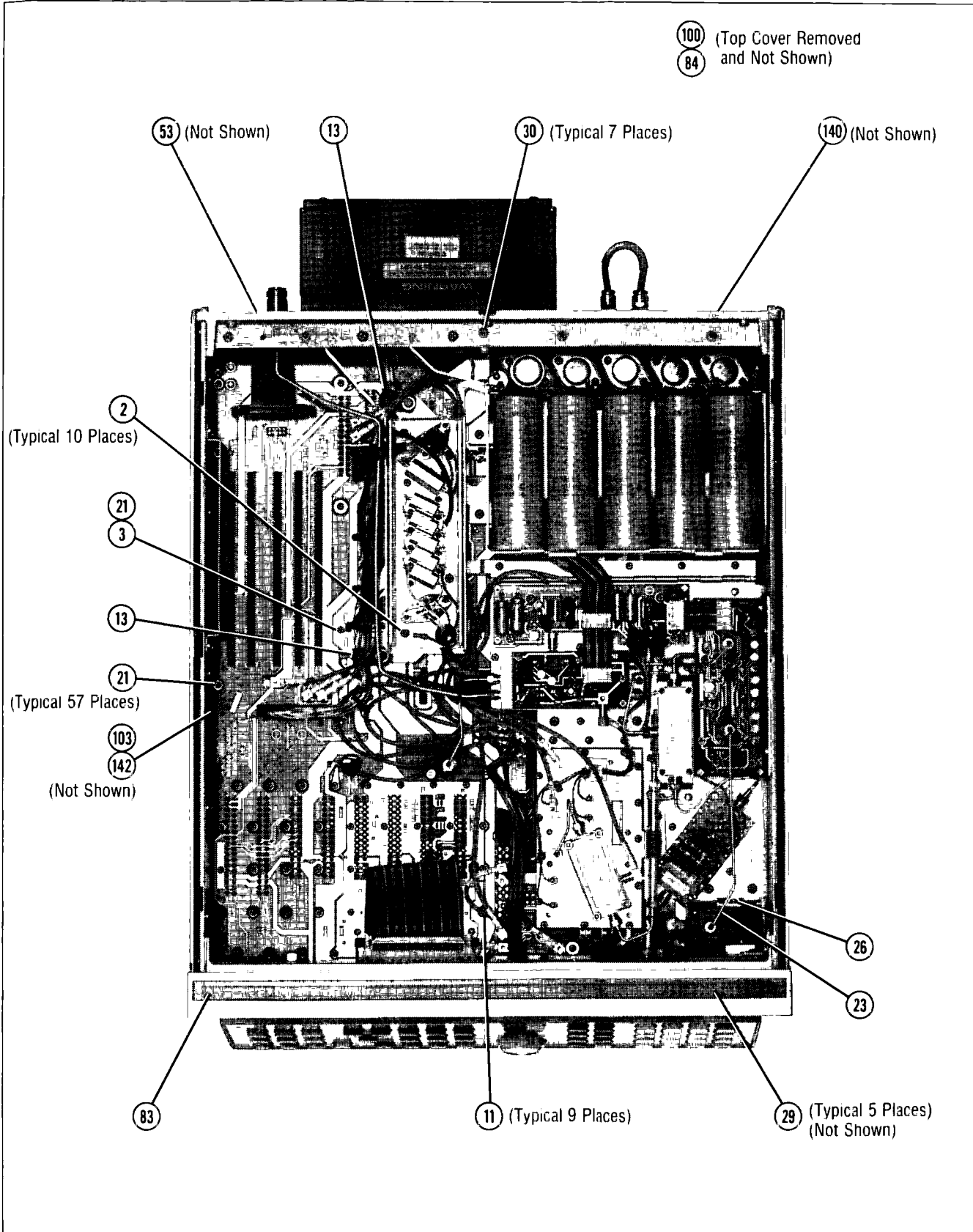

Figure J-5. Miscellaneous Mechanical & Chassis Parts (2 of 6)

Miscellaneous Mechanical and Chassis Parts

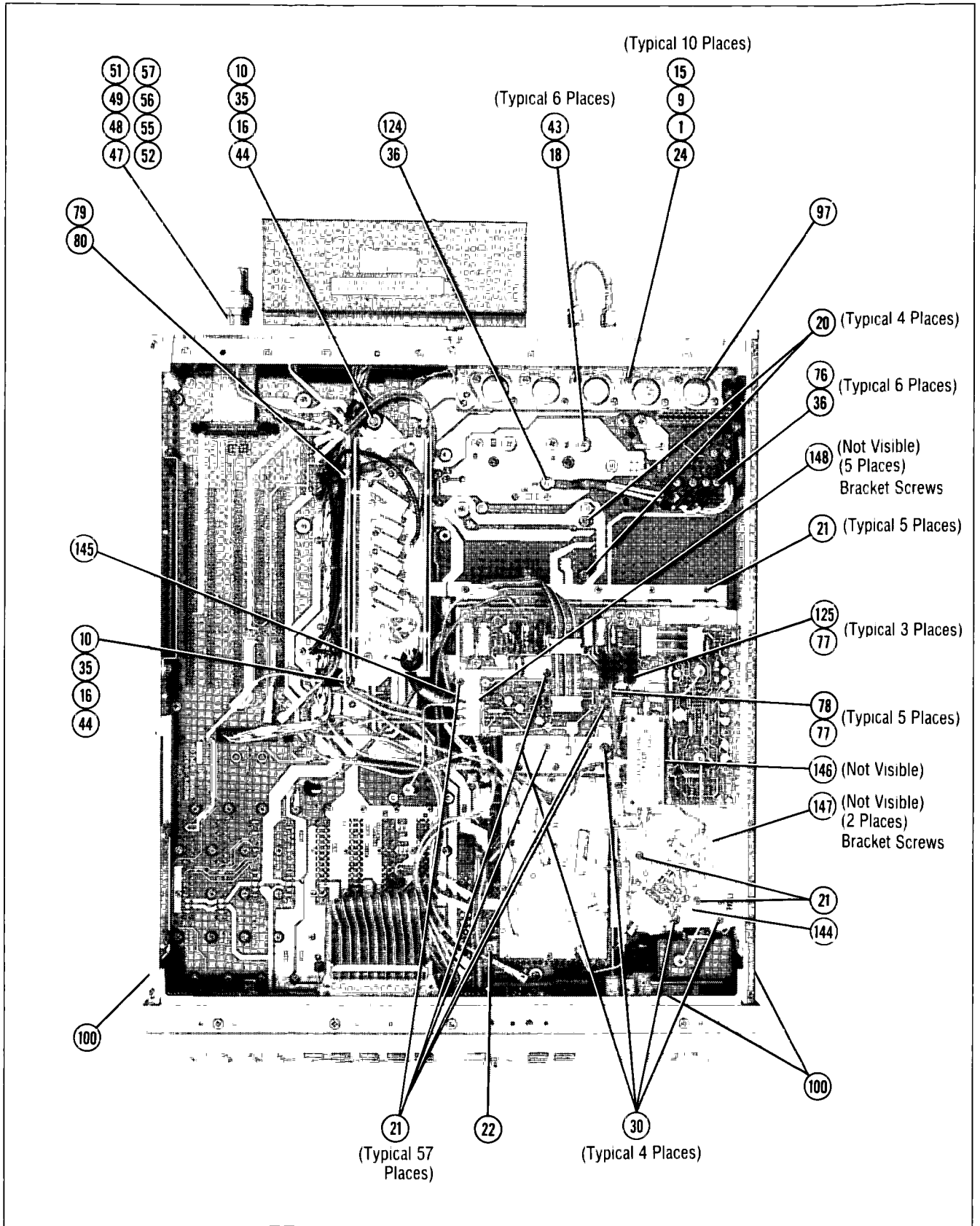

Figure J-5. Miscellaneous Mechanical & Chassis Parts (3 of 6)

Miscellaneous Mechanical and Chassis Parts

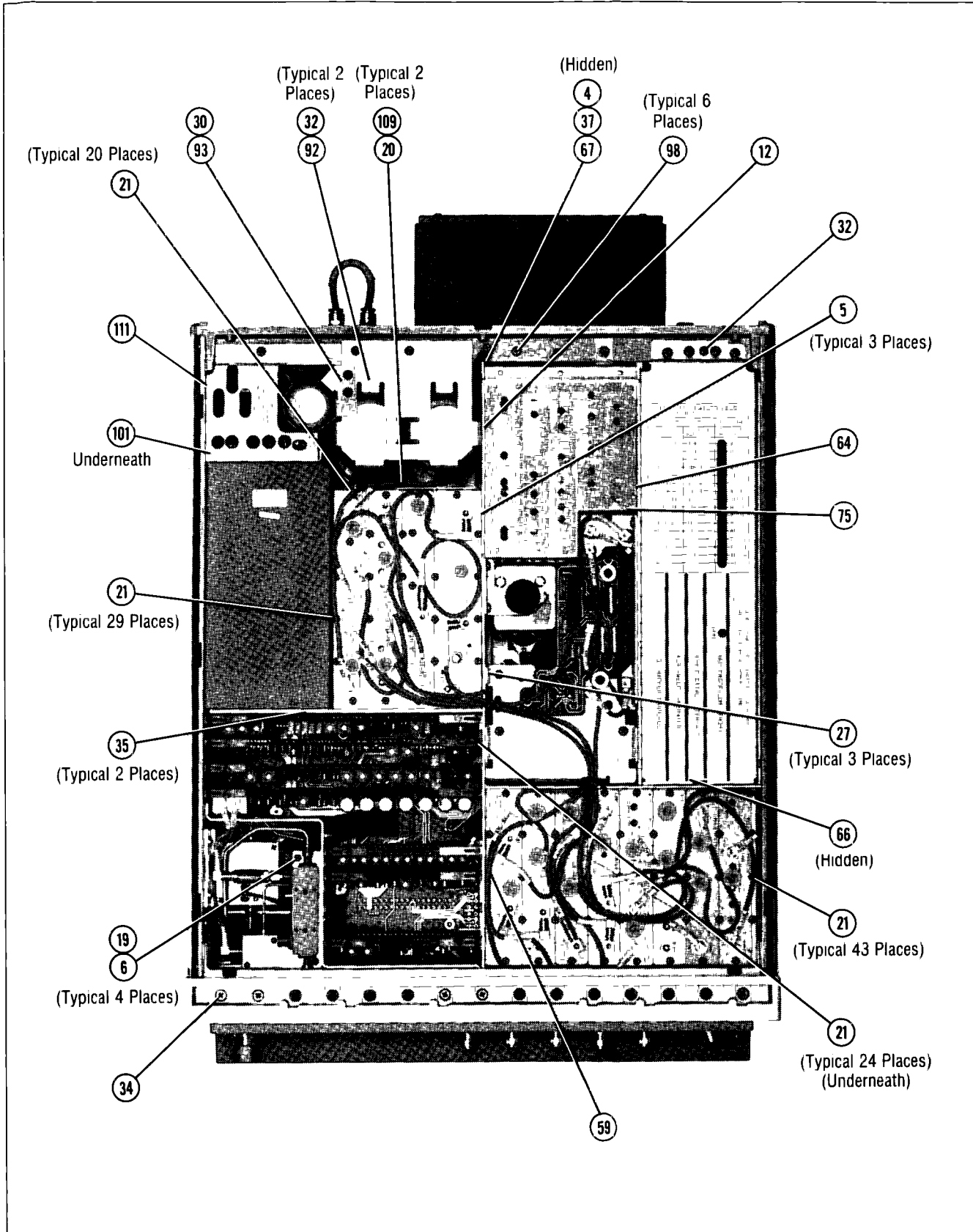

Figure J-5. Miscellaneous Mechanical & Chassis Parts (4 of 6)

Miscellaneous Mechanical and Chassis Parts

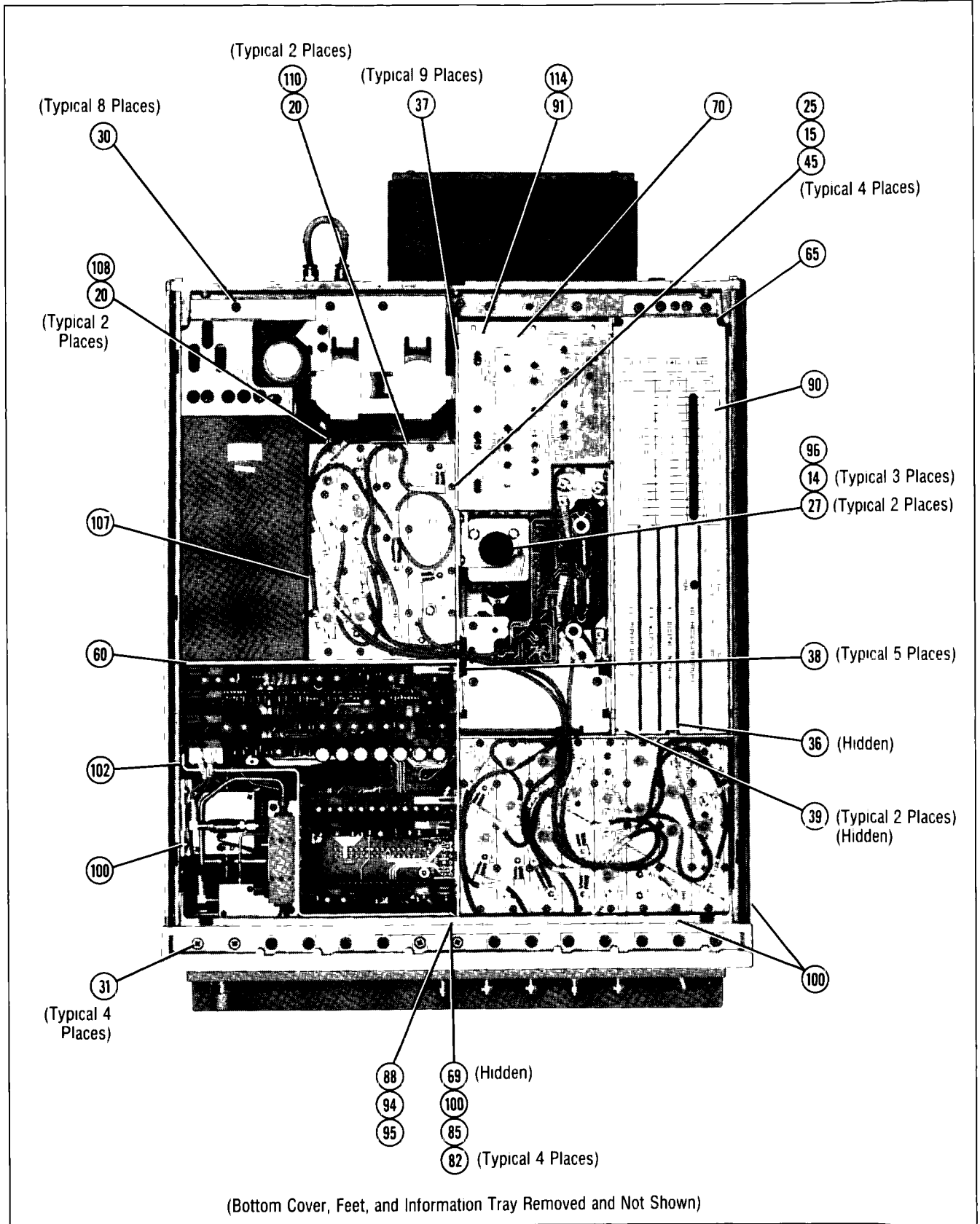

Figure J-5. Miscellaneous Mechanical & Chassis Parts (5 of 6)

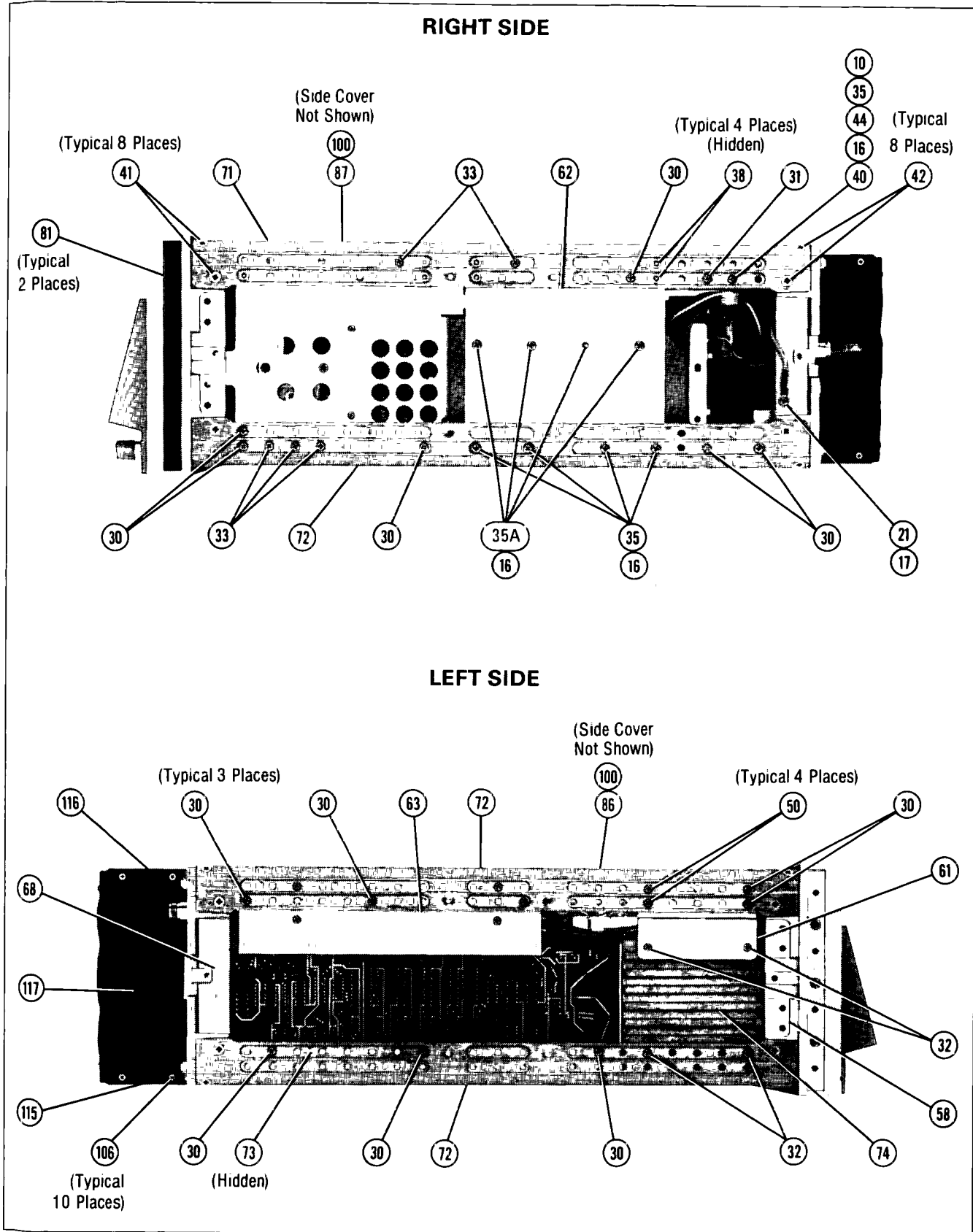

Figure J-5. Miscellaneous Mechanical & Chassis Parts (6 of 6)

Miscellaneous Mechanical and Chassis Parts

Table J-2. Miscellaneous Mechanical & Chassis Replaceable Parts

Reference Designation	HP Part Number	C D	Qty	Description	Mfr Code	Mfr Part Number
				MISCELLANEOUS MECHANICAL & CHASSIS PARTS		
1	0340-0923	8	10	INSULATOR-BSHG NYLON	28480	0340-0923
2	0360-0037	7	10	TERMINAL-SLDR LUG PL-MTG FOR-#6-SCR	28480	0360-0037
3	0360-0042	4	3	TERMINAL-SLDR LUG PL-MTG FOR-#6-SCR	28480	0360-0042
4	0400-0082	8	2	GROMMET-CHAN NCH 09-IN-GRV-WD	28480	0400-0082
5	0400-0219	3	3	GROMMET-RND 5-IN-ID 093-IN-GRV-WD	28480	0400-0219
6	0520-0127	6	4	SCREW-MACH 2-56 188-IN-LG PAN-HD-POZI	00000	ORDER BY DESCRIPTION
7	0570-0632	3	10	SCREW-SPCL 4-40 312-IN-LG PAN-HD-POZI	00000	ORDER BY DESCRIPTION
8	0590-1251	6	4	NUT-HEX 15/32-32	00000	ORDER BY DESCRIPTION
9	1200-0043	8	5	INSULATOR-XSTR ALUMINUM	28480	1200-0043
10	1400-0031	8	3	CLAMP-CABLE 375-DIA 5-WD NYL	28480	1400-0031
11	1400-0249	0	9	CABLE TIE 062- 625-DIA 091-WD NYL	06383	PLT1M-8
12	1400-0510	8	4	CLAMP-CABLE 15-DIA 62-WD NYL	28480	1400-0510
13	1400-0907	7	2	CLAMP-CABLE 187-DIA 5-WD FRTO-NYLON	95987	3/16-HFR
14	1520-0205	2	3	SHOCK MOUNT 31 HGT	28480	1520-0205
15	2190-0003	8	14	WASHER-LK HLCL NO 4 115-IN-ID	28480	2190-0003
16	2190-0006	1	15	WASHER-LK HLCL NO 6 141-IN-ID	28480	2190-0006
17	2190-0008	3	1	WASHER-LK EXT T NO 6 141-IN-ID	28480	2190-0008
18	2190-0011	8	6	WASHER-LK INTL T NO 10 195-IN-ID	28480	2190-0011
19	2190-0045	8	4	WASHER-LK HLCL NO 2 088-IN-ID	28480	2190-0045
20	2200-0103	2	4	SCREW-MACH 4-40 25-IN-LG PAN-HD-POZI	00000	ORDER BY DESCRIPTION
21	2200-0105	4	111	SCREW-MACH 4-40 312-IN-LG PAN-HD-POZI	00000	ORDER BY DESCRIPTION
22	2200-0107	6	1	SCREW-MACH 4-40 375-IN-LG PAN-HD-POZI	00000	ORDER BY DESCRIPTION
23	2200-0141	8	1	SCREW-MACH 4-40 312-IN-LG PAN-HD-POZI	00000	ORDER BY DESCRIPTION
24	2200-0149	6	10	SCREW-MACH 4-40 625-IN-LG PAN-HD-POZI	00000	ORDER BY DESCRIPTION
25	2200-0153	2	4	SCREW-MACH 4-40 875-IN-LG PAN-HD-POZI	00000	ORDER BY DESCRIPTION
26	2200-0166	7	3	SCREW-MACH 4-40 312-IN-LG 82 DEG	00000	ORDER BY DESCRIPTION
27	2360-0111	0	5	SCREW-MACH 6-32 188-IN-LG PAN-HD-POZI	00000	ORDER BY DESCRIPTION
28	2360-0113	2	13	SCREW-MACH 6-32 25-IN-LG PAN-HD-POZI	00000	ORDER BY DESCRIPTION
29	2360-0114	3	5	SCREW-MACH 6-32 25-IN-LG 82 DEG	00000	ORDER BY DESCRIPTION
30	2360-0115	4	34	SCREW-MACH 6-32 312-IN-LG PAN-HD-POZI	00000	ORDER BY DESCRIPTION
31	2360-0116	5	4	SCREW-MACH 6-32 312-IN-LG 82 DEG	00000	ORDER BY DESCRIPTION
32	2360-0117	6	10	SCREW-MACH 6-32 375-IN-LG PAN-HD-POZI	00000	ORDER BY DESCRIPTION
33	2360-0119	8	10	SCREW-MACH 6-32 438-IN-LG PAN-HD-POZI	00000	ORDER BY DESCRIPTION
34	2360-0122	3	1	SCREW-MACH 6-32 5-IN-LG 82 DEG	00000	ORDER BY DESCRIPTION
35	2360-0197	2	11	SCREW-MACH 6-32 375-IN-LG PAN-HD-POZI	00000	ORDER BY DESCRIPTION
35A	2360-0193	8	4	SCREW-MACH 6-32 25-IN-LG PAN-HD-POZI	00000	ORDER BY DESCRIPTION
36	2360-0331	6	9	SCREW-MACH 6-32 25-IN-LG PAN-HD-POZI	28480	2360-0331
37	2360-0333	8	26	SCREW-MACH 6-32 25-IN-LG 100 DEG	28480	2360-0333
38	2360-0334	9	9	SCREW-MACH 6-32 312-IN-LG 100 DEG	28480	2360-0334
39	2360-0360	1	2	SCREW-MACH 6-32 438-IN-LG 100 DEG	28480	2360-0360
40	2420-0002	6	2	NUT-HEX-DBL-CHAM 6-32-THD 109-IN-THK	28480	2420-0002
41	0515-1331	5	16	SCREW-MACH M4x0 7x6mm FH 90	28480	0515-1331
42	0515-0896	5	8	SCREW-MACH M4x0 7x10mm FH 90	28480	0515-0896
43	2680-0129	8	6	SCREW-MACH 10-32 312-IN-LG PAN-HD-POZI	00000	ORDER BY DESCRIPTION
44	3050-0066	8	2	WASHER-FL MTLC NO 6 147-IN-ID	28480	3050-0066
45	3050-0105	6	4	WASHER-FL MTLC NO 4 125-IN-ID	28480	3050-0105
46	3050-0227	3	7	WASHER-FL MTLC NO 6 149-IN-ID	28480	3050-0227
47	1250-0915	8	1	CONTACT-RF CONN SER APC-N FEMALE	9D949	131-149
48	1250-1577	0	1	CONNECTOR-RF FEMALE TYPE N	28480	1250-1577
49	2190-0104	0	1	WASHER-LK INTL T 7/16 IN 439-IN-ID	28480	2190-0104
50	2360-0115	4		SCREW-MACH 6-32 312-IN-LG PAN-HD-POZI	00000	ORDER BY DESCRIPTION
51	2950-0132	6	1	NUT-HEX-DBL-CHAM 7/16-28-THD 094-IN-THK	00000	ORDER BY DESCRIPTION
52	5040-0306	0	1	INSULATOR	28480	5040-0306
53	08340-00096	7	1	PANEL-REAR (AUX OUTPUT)	28480	08340-00096
54	08340-00056	9	1	DEFLECTOR-AIR	28480	08340-00056
55	08555-20093	5	1	CONTACT JACK	28480	08555-20093
56	08555-20094	6	1	BODY-BULK HEAD	28480	08555-20094
57	08761-2027	4	1	INSULATOR	28480	08761-2027
58	5021-5805	4	1	FRAME-FRONT (METRIC)	28480	5021-5805
59	08340-00076	3	1	CENTER DIVIDER	28480	08340-00076
60	08340-00002	5	1	CHASSIS-RF MOD (REAR)	28480	08340-00002
61	08340-00003	6	1	BRACKET-20-30 MOUNT	28480	08340-00003
62	08340-00004	7	1	BRACKET-MOUNT TRANS	28480	08340-00004
63	08340-00005	8	1	SUPPORT-MOM BOARD	28480	08340-00005
64	08340-00020	7	1	DIVIDER PROCESSOR	28480	08340-00020
65	08340-00029	6	1	GUIDE PLATE-PC BOARDS	28480	08340-00029

Miscellaneous Mechanical and Chassis Parts

Table J-2. Miscellaneous Mechanical & Chassis Replaceable Parts

Reference Designation	HP Part Number	C	D	Qty	Description	Mfr Code	Mfr Part Number
66	08340-00031	0		1	SUPPORT-PC PROCESSOR	28480	08340-00031
67	08340-20051	6		1	SUPPORT-REAR CENTER	28480	08340-20051
68	08340-20234	7		1	FRAME (REAR) MOD (METRIC)	28480	08340-20234
69	08340-20054	9		1	SUPPORT-FRONT CENTER DIVIDER	28480	08340-20054
70	08340-20056	1		1	GUIDE-POWER SUPPLY	28480	08340-20056
71	08340-20236	9		1	STRUT-CORNER (TOP) (METRIC)	28480	08340-20236
72	08340-20238	1		3	STRUT-CORNER MOD (METRIC)	28480	08340-20238
73	85660-00004	6		1	BRACKET-PIVOT PROCESSOR	28480	85660-00004
74	85660-20190	3		1	HOUSING-20-30 MHZ	28480	85660-20190
75	86701-20006	2		1	GUIDE-FRONT PC	28480	86701-20006
76	0360-0037	7		6	TERMINAL-SLDR LUG PL-MTG FOR-#6-SCR	28480	0360-0037
77	1251-4223	1		10	CONTACT-CONN U/W-POST-TYPE FEM CRP	28480	1251-4223
78	1251-6594	3		1	CONNECTOR HOUSING-5 FEMALE IR	28480	1251-6594
79	8120-0579	2		1	CABLE-SHLD 22AWG 5-CNDCT JGK-JKT	28480	8120-0579
80	8150-0005	2		1	WIRE 22AWG BK 300V PVC 7X30 105C	28480	8150-0005
81	5001-0440	1		2	TRIM-SIDE F F	28480	5001-0440
82	5040-7201	8		4	FOOT-BOTTOM	28480	5040-7201
83	5040-7202	9		1	TRIM STRIP (TOP)	28480	5040-7202
84	5061-9435	8		1	COVER FM TOP (METRIC)	28480	5061-9435
85	5061-9447	2		1	COVER FM BOTTOM (METRIC)	28480	5061-9447
86	5061-9462	1		1	COVER SIDE (METRIC)	28480	5061-9462
87	5061-9517	7		1	COVER FM PERFORATED (METRIC)	28480	5061-9517
88	5061-2033	8		1	INFO TRAY ASSY KIT	28480	5061-2033
89	08340-00086	5		1	DRESS PANEL-KEYBOARD	28480	08340-00086
90	08340-00074	1		1	HOLDER-PC COVER	28480	08340-00074
91	08340-00040	1		1	HOLDER-POWER SUPPLY BOARDS	28480	08340-00040
92	08340-00060	5		1	PLATE-CAP HOLDER	28480	08340-00060
93	08340-00061	6		1	HOLDER-CAP HOLDER	28480	08340-00061
94	08340-90246	8		1	INFO CARD #1	28480	08340-90246
95	08340-90247	9		1	INFO CARD #2	28480	08340-90247
96	85660-00025	1		1	SHOCK MOUNT (TOP)	28480	85660-00025
97	85660-00027	3		1	INSULATOR-HEAT SINK	28480	85660-00027
98	86701-00028	6		1	SPRING-FLAT	28480	86701-00028
99	1990-0720	1		1	DISPLAY-SPECIAL 1 HI	28480	1990-0720
100	8160-0226	0		12	RFI RND STR 050D	28480	8160-0226
101	08340-00006	9		1	SUPPORT-PC RECT	28480	08340-00006
102	08340-00008	1		1	CHASSIS RF MOD (FRONT)	28480	08340-00008
103	08340-00064	9		1	POCKET (Holds Cal. Constant Data)	28480	08340-00064
104	6960-0009	1		1	HOLE PLUG 531-D-HOLE	28480	6960-0009
105	0380-0644	4		2	STANDOFF-HEX 400-IN-LG 6-32 THD	28480	0380-0644
106	2200-0164	5		10	SCREW-MACH 4-40 188-IN-LG	28480	2200-0164
107	5021-3208	7		1	HOUSING-MACHINED	28480	5021-3208
108	86701-00029	7		1	BAFFLE-AIR TOP	28480	86701-00029
109	86701-00024	2		1	SCOOP-AIR	28480	86701-00024
110	86701-00030	0		1	BAFFLE-AIR BOTTOM	28480	86701-00030
111	08340-00067	2			COVER-RECT BOARD	28480	08340-00067
112	08340-00018	3			FAN FILTER	28480	08340-00018
113	08340-00017	2			GRILL-AIR	28480	08340-00017
114	3030-0152	1		2	SCREW-SET 4-40 312-IN-LG SMALL CUP PT	28480	3030-0152
115	08340-00016	1		1	FAN HOUSING-BOTTOM	28480	08340-00016
116	08340-00012	7		1	FAN HOUSING-TOP	28480	08340-00012
117	08340-00097	8			FAN GRILL HOUSING	28480	08340-00097
118	1520-0230	3		4	SHOCK MOUNT	28480	1520-0230
119	08340-00016	1		1	BASE PLATE-FAN	28480	08340-00016
120	85660-20092	4		4	RUBBER SHOCK MOUNT	28480	85660-20092
121	2360-0196	1		4	SCREW-MACH 6-32 375-IN-LG 100 DEG	28480	2360-0196
122	2190-0009	4		2	WASHER-LK INT T NO 8 168-IN-ID	28480	2190-0009
123	2510-0051	6		2	SCREW-MACH 8-32 625-IN-LG PAN-HD-POZI	28480	2510-0051
124	0360-0043	5			TERMINAL-SLDR LUG PL-MTG FOR-NO 6-SCR	28480	0360-0043
125	1251-6796	7			CONN-POST TYPE	28480	1251-6796
126	0360-1632	0		4	TERMINAL-SLDR LUG LK-MTG FOR-#3/8-SCR	28480	0360-1632
127	0362-0227	1		2	CONNECTOR-SGL CONT SKT 1 14-MM-BSC-SZ	28480	0362-0227
128	1250-0083	1		8	CONNECTOR-RF BNC FEM SGL-HOLE-FR 50-OHM	28480	1250-0083
129	1250-0102	5		3	CONNECTOR-RF BNC FEM SGL-HOLE-FR 50-OHM	28480	1250-0102
130	1251-0064	0		1	CONNECTOR 25-PIN F D SERIES	28480	1251-0064
131	1251-2942	7		2	CONNECTOR-RACK & PANEL LOCK	28480	1251-2942
132	1251-3653	9		26	CONNECTOR CONTACT FEMALE 025	28480	1251-3653
133	1251-6781	0		1	CONNECTOR RECEPTACLE 3 MALE CONTACT	28480	1251-6781
134	1251-7374	9		1	CONNECTOR HOUSING-28 FEMALE 2R	28480	1251-7374
135	2190-0016	3		4	WASHER-LK INTL T 3/8 IN 377-IN-ID	28480	2190-0016

Miscellaneous Mechanical and Chassis Parts

Table J-2. Miscellaneous Mechanical & Chassis Replaceable Parts

Reference Designation	HP Part Number	C D	Qty	Description	Mfr Code	Mfr Part Number
136	2190-0068	5	3	WASHER-LK INTL T 1/2 IN 505-IN-ID	28480	2190-0068
137	2190-0104	0	1	WASHER-LK INTL T 7/16 IN 439-IN-ID	28480	2190-0104
138	2950-0001	8	8	NUT-HEX-DBL-CHAM 3/8-32-THD 094-IN-THK	00000	ORDER BY DESCRIPTION
139	2950-0054	1	3	NUT-HEX-DBL-CHAM 1/2-28-THD 125-IN-THK	00000	ORDER BY DESCRIPTION
140	08340-00098	9	1	REAR PANEL	28480	08340-00098
141	3101-0163	5	1	SWITCH KIT	28480	3101-0163
142	9222-0090	9	1	PLASTIC JACKET (Holds Cal Constant Data)	28480	9222-0090
143	08340-00070	7	1	BRACKET	28480	08340-00070
144	08340-00089	4	1	A18 MOUNTING PLATE	28480	08340-00089
145	08340-00090	7	1	A16 MOUNTING PLATE	28480	08340-00090
146	08340-00079	6	1	A17 MOUNTING PLATE	28480	08340-00079
147	2200-0164	5	2	SCREW-MACH 4-40 188-IN-LG UNCT 82 DEG	00000	ORDER BY DESCRIPTION
148	2200-0165	6	5	SCREW-MACH 4-40 25-IN-LG 82 DEG	00000	ORDER BY DESCRIPTION

Option Configurations

Table J-3. HP 8340B Option Configurations

Reference Designation	HP Part Number	C D	Qty	Description	Mfr Code	Mfr Part Number
HP 8340B OPTION CONFIGURATIONS						
OPTION 001: FRONT PANEL RF OUTPUT NO ATTENUATOR						
A63	08340-00028	5	1	DELETE THE FOLLOWING		
W18	08340-60175	9	1	ATTENUATOR MOUNTING PLATE	28480	08340-00028
W19	08340-20119	7	1	90 DB PROGRAMMABLE ATTENUATOR	28480	08340-60175
W19	08340-20117	5	1	CABLE ASSY-RIGID COAX A10J3 TO A63J1	28480	08340-20119
				CABLE ASSY-RIGID COAX A63J2 TO J5	28480	08340-20117
W21	08340-20121	1	1	ADD THE FOLLOWING		
				CABLE ASSY-RIGID COAX A10J3 TO J5	28480	08340-20121
OPTION 004: REAR PANEL RF OUTPUT WITH ATTENUATOR						
W19	08340-20076	5	1	DELETE THE FOLLOWING	28480	08340-20076
	08340-20117	5	1	RF CONNECTOR BRACKET	28480	08340-20117
				CABLE ASSY-RIGID COAX A63J2 TO J5		
W20	08340-20122	2	1	ADD THE FOLLOWING	28480	08340-20122
	83592-20063	2	1	CABLE ASSY-RIGID COAX A63J2 TO J20	28480	83592-20063
	83595-20004	4	1	PLUG BUTTON-FRONT PANEL	28480	83595-20004
				FRONT PANEL CONNECTOR SPACER		
	1400-0053	4	1	CLAMP-CABLE 172-DIA 375-WD NYL	28480	1400-0053
	2190-0104	0	1	WASHER-LK INTL T 7/16 IN 439-IN-ID	28480	2190-0104
	2950-0132	6	1	NUT-DBL-CHAM 7/16-28-THD 094-IN-THK	28480	2950-0132
	2200-0145	2	1	SCREW-MACH 4-40 438-IN-LG PAN-HD-POZI	28480	2200-0145
	2190-0019	6	1	WASHER-LK HLCL NO 4 155-IN-ID	28480	2190-0019
	3050-0105	6	1	WASHER-FL MTLCL NO 4 125-IN-I	28480	3050-0105
OPTION 005: REAR PANEL RF OUTPUT NO ATTENUATOR						
W18	08340-00028	5	1	DELETE THE FOLLOWING	28480	08340-00028
W19	08340-20076	5	1	ATTENUATOR MOUNTING PLATE	28480	08340-20076
W19	08340-20119	7	1	RF CONNECTOR BRACKET	28480	08340-20119
A63	08340-20117	5	1	CABLE ASSY-RIGID COAX A10J3 TO A63J1	28480	08340-20117
				CABLE ASSY-RIGID COAX A63J2 TO J5	28480	08340-20117
				90 DB PROGRAMMABLE ATTENUATOR	28480	08340-60175
W22	08340-20120	0	1	ADD THE FOLLOWING	28480	08340-20120
	83595-20004	4	1	CABLE ASSY-RIGID COAX	28480	83595-20004
	83592-20063	2	1	FRONT PANEL CONNECTOR SPACER	28480	83592-20063
				PLUG BUTTON-FRONT PANEL		
	1400-0053	4	1	CLAMP-CABLE 172-DIA 375-WD NYL	28480	1400-0053
	2190-0104	0	1	WASHER-LK INTL T 7/16 IN 439-IN-ID	28480	2190-0104
	2950-0132	6	1	NUT-DBL-CHAM 7/16-28-THD 094-IN-THK	28480	2950-0132
OPTION 806: CHASSIS SLIDE KIT						
	5061-9517	7	1	DELETE THE FOLLOWING	28480	5061-9517
	5061-9462	1	1	CHASSIS COVER (SIDE) PERFORATED	28480	5061-9462
				CHASSIS COVER (SIDE)		
	08340-60136	2	1	ADD THE FOLLOWING	KIT	2848008340-60136
				SLIDE RACK MOUNT		
OPTION 850: INTERFACE CABLE FOR OPERATION WITH HP 8410B/C						
	08410-60146	9	1	ADD THE FOLLOWING	28480	08410-60146
				INTERCONNECT CABLE		
OPTION 908: RACK FLANGES WITHOUT HANDLES						
	5061-9678	1	1	ADD THE FOLLOWING	28480	5061-9678
				RACK FLANGES WITHOUT HANDLES KIT		
OPTION 913: RACK FLANGES WITH HANDLES						
	5061-9772	6	1	ADD THE FOLLOWING	28480	5061-9772
				RACK FLANGES WITH HANDLES KIT		

INTRODUCTION

This manual has been written for and applies directly to instruments with serial numbers prefixed as indicated on the title page. Earlier versions of the instrument (serial prefixes lower than the one indicated on the title page) may be slightly different in design or appearance. The purpose of this section of the manual is to document these differences. With the information provided in this section, this manual can be corrected so that it applies to an earlier version or configuration of the instrument.

Later versions of the instrument (serial prefixes higher than the one indicated on the title page) are documented in a yellow Manual Change Supplement. If your instrument serial number prefix is higher than the one on the title page, order a copy of the supplement from your nearest Hewlett-Packard office. When ordering Manual Change Supplements, quote the HP model number, print date, and manual part number from the title page of this manual.

HOW TO USE THE BACKDATING INFORMATION

This section is divided into subsections associated with a specific serial number prefix. Check the serial number prefix of the instrument and refer to the table below for the corresponding documentation changes required

Serial Number Prefix	Use information in subsection(s)
2624A	G through A
2634A	G through B
2643A	G through C
2650A	G through D
2730A	G through E
2802A	G and F
2804A	G

NOTE: Incorporate the backdating changes in reverse alphabetical order. For example: the instrument has serial number prefix 2643A. Beginning with backdating information G make the changes as noted, continue with backdating F, E, D, and lastly, incorporate backdating C.



BACKDATING A (serial number prefix 2624A)

Change the A26 linear modulator assembly to part number 08340-60264. Refer to Service Note 8340B-1 for details.

BACKDATING B (serial number prefix 2634A)

The FM input jack (J22) configuration is different. Refer to pages J-1 and J-7, delete the static protection diodes, CR3 and CR4 and capacitor C4.

BACKDATING C (serial number prefix 2643A)

Change the A26 linear modulator assembly to part number 08340-60283, this assembly is electrically the same as, A26 part number 08340-60284.

Change the A27 level control assembly to part number 08340-60022, this assembly is electrically the same as, A27 part number 08340-60237.

BACKDATING D (serial number prefix 2650A)

The fan housing assembly is different.

Instructions

Replace the existing manual pages with the pages provided in this backdating subsection to reflect the instrument configuration.

Replace the following pages:

- G-3 through G-6, Volume 2, section G – Front Panel/Rear Panel
- J-1 and J-2, Volume 2, section J – Major Assemblies
- J-7 and J-8, Volume 2, section J – Major Assemblies
- J-11 and J-12, Volume 2, section J – Major Assemblies
- J-17 through J-20, Volume 2, section J – Major Assemblies

Rear Panel Component-Level Information

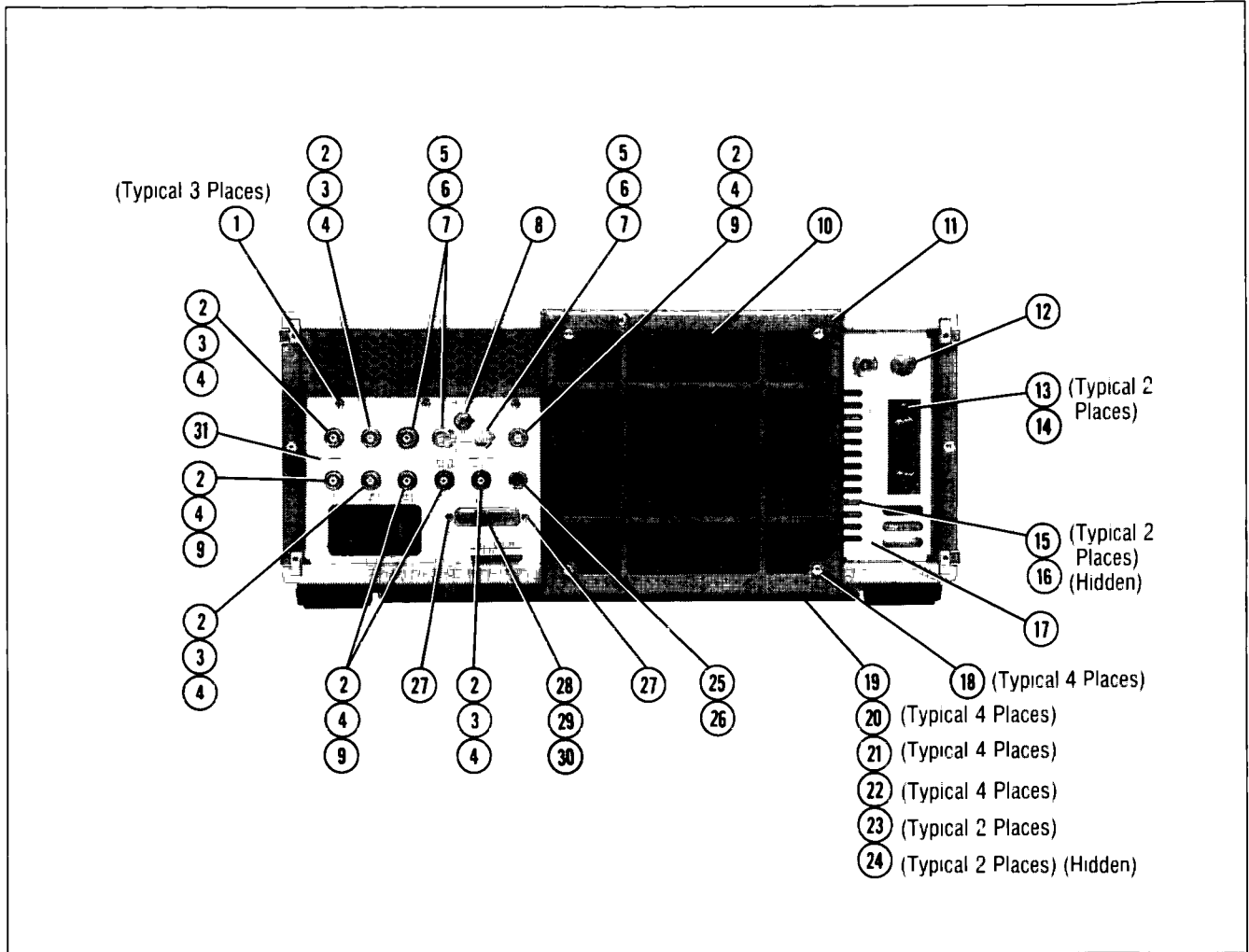

Figure G-1. Rear Panel Replaceable Parts

Rear Panel Component-Level Information

Table G-1. Rear Panel Replaceable Parts

Reference Designation	HP Part Number	C D	Qty	Description	Mfr Code	Mfr Part Number
				REAR PANEL		
1	2200-0105	4	99	SCREW-MACH 4-40 312-IN-LG PAN-HD-POZI	00000	ORDER BY DESCRIPTION
2	1250-0083	1	8	CONNECTOR-RF BNC FEM SGL-HOLE-FR 50-OHM	28480	1250-0083
3	0360-1632	0	4	TERMINAL-SLDR LUG LK-MTG FOR-#3/8-SCR	28480	0360-1632
4	2950-0001	8	8	NUT-HEX--DBL-CHAM 3/8-32-THD 094-IN-THK	00000	ORDER BY DESCRIPTION
5	1250-0102	5	3	CONNECTOR-RF BNC FEM SGL-HOLE-FR 50-OHM	28480	1250-0102
6	2190-0068	5	3	WASHER-LK INTL T 1/2 IN 505-IN-ID	28480	2190-0068
7	2950-0054	1	3	NUT-HEX-DBL-CHAM 1/2-28-THD 125-IN-THK	00000	ORDER BY DESCRIPTION
8	3101-0163	5	1	SWITCH KIT	28480	3101-0163
9	2190-0016	3	4	WASHER-LK INTL T 3/8 IN 377-IN-ID	28480	2190-0016
10	08340-00018	3	1	FAN FILTER	28480	08340-00018
11	08340-00017	2	1	GRILL AIR	28480	08340-00017
12	6960-0009	1	1	HOLE PLUG 531-D-HOLE	28480	6960-0009
13	0380-0644	4	2	STANDOFF-HEX 400-IN-LG 6-32 THD	28480	0380-0644
14	2420-0002	6	2	NUT-HEX-DBL-CHAM 6-32-THD 109-IN-THK	28480	2420-0002
15	2360-0115	4	37	SCREW-MACH 6-32 312-IN-LG PAN-HD-POZI	00000	ORDER BY DESCRIPTION
16	08340-00056	9	1	DEFLECTOR-AIR	28480	08340-00056
17	08340-00011	6	1	PANEL-REAR (AUX OUTPUT)	28480	08340-00011
18	2360-0119	8	10	SCREW-MACH 6-32 438-IN-LG PAN-HD-POZI	00000	ORDER BY DESCRIPTION
19	08340-00016	1	1	BASE PLATE-FAN	28480	08340-00016
20	1520-0230	3	4	SHOCK MOUNT	28480	1520-0230
21	85660-20092	4	4	SNUBBER SHOCK MOUNT	28480	85660-20092
22	2360-0196	1	4	SCREW-MACH 6-32 375-IN-LG 100 DEG	28480	2360-0196
23	2190-0009	4	2	WASHER-LK INT T NO 8 168-IN-ID	28480	2190-0009
24	2510-0051	6	2	SCREW-MACH 8-32 625-IN-LG PAN-HD-POZI	28480	2510-0051
25	1251-6781	0	1	CONNECTOR RECEPTACLE 3 MALE CONTACT	28480	1251-6781
26	2190-0104	0	1	WASHER-LK INTL T 7/16 IN 439-IN-ID	28480	2190-0104
27	1251-2943	7	2	CONNECTOR-RACK & PANEL LOCK	28480	1251-2942
28	1251-0064	0	1	CONNECTOR 25-PIN F D SERIES	28480	1251-0064
29	1251-3653	9	26	CONNECTOR CONTACT FEMALE 025	28480	1251-3653
30	1251-7374	9	1	CONNECTOR HOUSING-28 FEMALE 2R	28480	1251-7374
31	08340-00010	5	1	REAR PANEL	28480	08340-00010

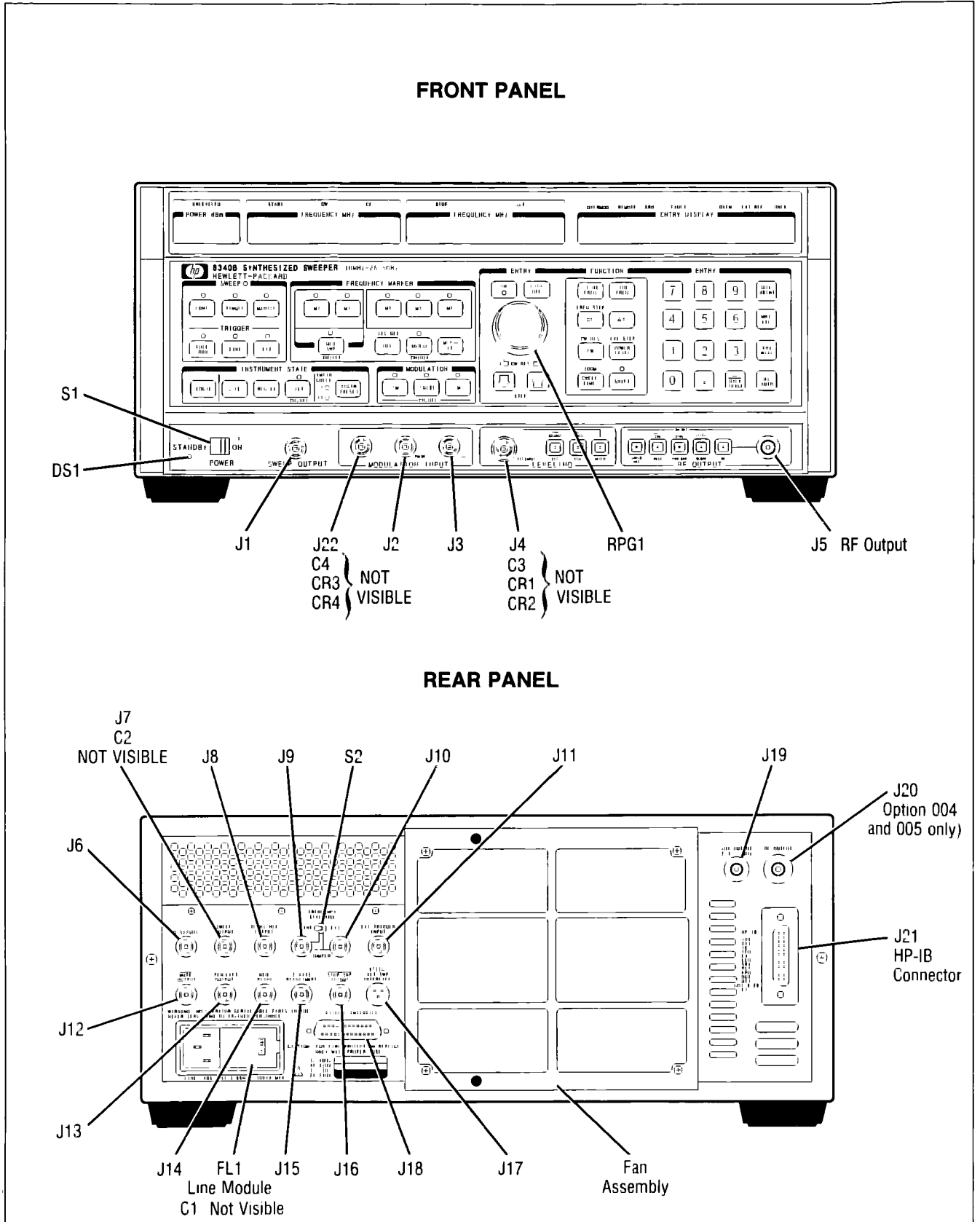

Figure J-1. Front and Rear Panels

Major Assemblies and Components Location

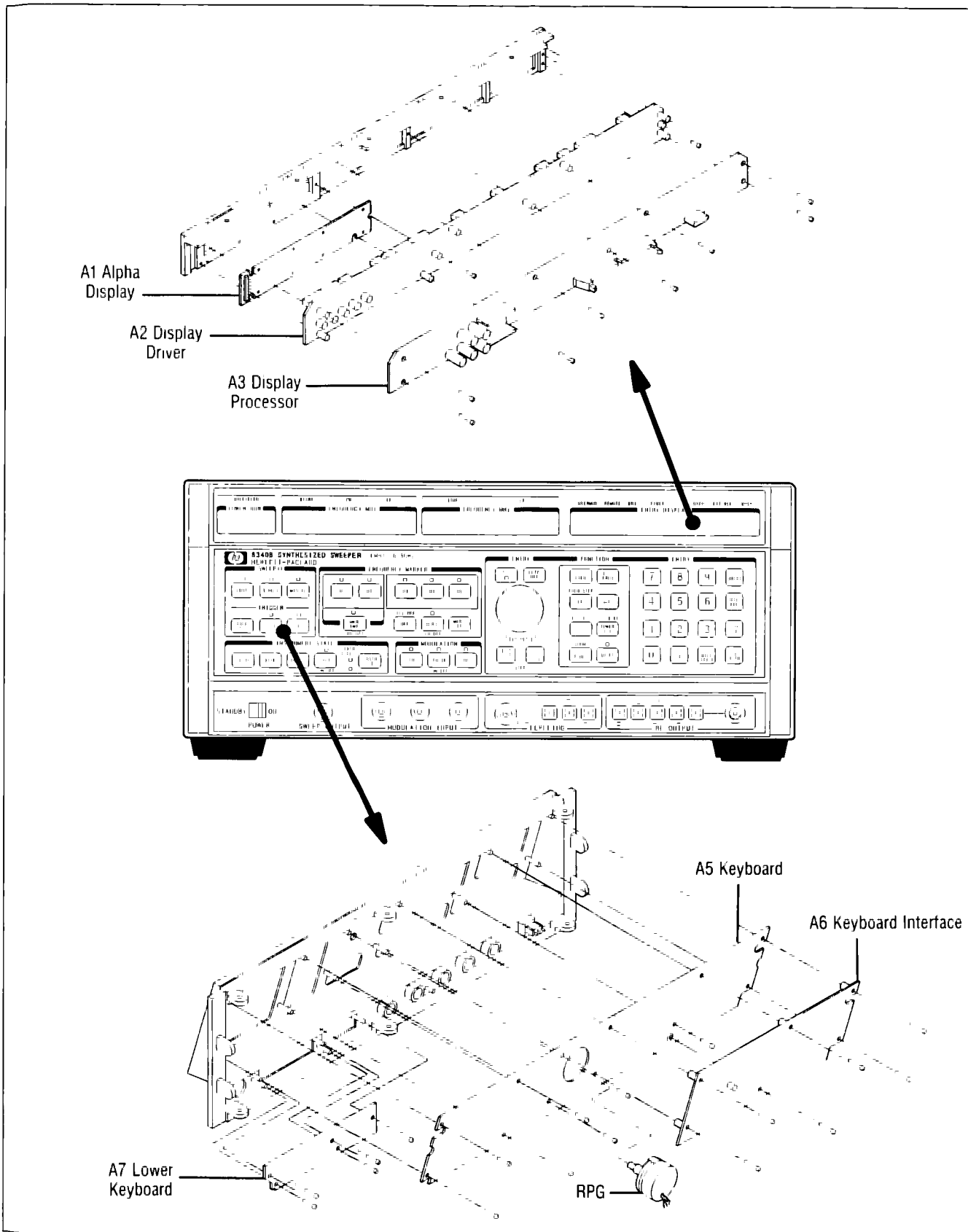

Figure J-2. Front Panel Assemblies

Major Assemblies and Components Location

Table J-1. Miscellaneous Electrical Replaceable Parts

Reference Designation	HP Part Number	C D	Qty	Description	Mfr Code	Mfr Part Number
MISCELLANEOUS ELECTRICAL PARTS						
A63	08340-60175	9	1	90 DB PROGRAMMABLE ATTENUATOR	28480	08340-60175
AT1	0960-0638	8	1	PERIPHERAL MODE ISOLATOR	28480	0960-0638
AT3	0960-0701	4	1	3.7 GHz ISOLATOR	28480	0960-0701
B1	08340-60055	4	1	FAN ASSEMBLY Includes B1W1 and the following parts	28480	08340-60055
	0360-0535	0	2	TERMINAL TEST POINT PCB	00000	ORDER BY DESCRIPTION
	0890-0029	0	1	TUBING-HS 187-D/ 093-RCVD 02-WALL	28480	0890-0029
	0890-0983	5	1	TUBING-HS 125-D/ 063-RCVD 02-WALL	28480	0890-0983
	1251-4223	1	2	CONNECTOR- CONT F 025	28480	1251-4223
	1251-6796	7	1	CONNECTOR HOUSING- 3 FEMALE IR	28480	1251-6796
	1400-0249	0	1	CABLE TIE 062- 625-DIA 091-WD NYL	06383	FLT1M-8
	1520-0230	3	4	SHOCK MOUNT 27-EFF-HGT 2-LB-LOAD-CAP	28480	1520-0230
	2190-0017	4	2	WASHER-Lk HLCL NO 8 168-IN-ID	28480	2190-0017
	2200-0770	9	10	SCREW-MACH 4-40 188-IN-LG 100 DEG	00000	ORDER BY DESCRIPTION
	2360-0119	8	4	SCREW-MACH 6-32 438-IN-LG PAN-HD-POZI	00000	ORDER BY DESCRIPTION
	2360-0196	1	4	SCREW-MACH 6-32 375-IN-LG 100 DEG	00000	ORDER BY DESCRIPTION
	2510-0135	7	2	SCREW-MACH 8-32 2.25-IN-LG PAN-HD-POZI	00000	ORDER BY DESCRIPTION
	2680-0137	8	1	SCREW-MACH 10-32 188-IN-LG PAN-HD-SLT	00000	ORDER BY DESCRIPTION
	3160-0371	1	1	FAN-TBAX 180-CFM 115V 50/60-HZ	28480	3160-0371
	8150-0011	0	1	WIRE 22AWG G 300V PVC 7X30 105C	28480	8150-0011
	8150-0447	6	1	WIRE 24AWG BK 300V PVC 7X32 80C	28480	8150-0447
	08340-00012	7	1	HOUSING FAN (TOP)	28480	08340-00012
	08340-00013	8	1	HOUSING FAN (BOTTOM)	28480	08340-00013
	08340-00014	9	1	HOUSING FAN (GRILLE)	28480	08340-00014
	08340-00016	1	1	BASE PLATE	28480	08340-00016
	08340-00017	2	1	GRILL AIR FILTER	28480	08340-00017
	08340-00018	3	1	FILTER-AIR	28480	08340-00018
	85660-20092	4	4	SNUBBER-SHOCK MOUNT	28480	85660-20092
C1	0160-4065	5	1	CAPACITOR-FXD 1UF ±20% 250VAC (RMS) (On FL1, line module)	28480	0160-4065
C2	0160-4819	7	1	CAPACITOR-FXD 2200PF ±5% 100VDC CER (On J7, sweep output)	28480	0160-4819
C3	0160-4832	4	2	CAPACITOR-FXD 01UF ±10% 100VDC CER (On J4, external input)	28480	0160-4832
C4	0160-4832	4	1	CAPACITOR-FXD 01UF ±10% 100VDC CER (On J22, FM input)	28480	0160-4832
CR1	1901-0179	7	4	DIODE-SWITCHING 15V 50MA 750PS DO-7 (On J4, external input)	28480	1901-0179
CR2	1901-0179	7	1	DIODE-SWITCHING 15V 50MA 750PS DO-7 (On J4, external input)	28480	1901-0179
CR3	1901-0179	7	1	DIODE-SWITCHING 15V 50MA 750PS DO-7 (On J22, FM input)	28480	1901-0179
CR4	1901-0179	7	1	DIODE-SWITCHING 15V 50MA 750PS DO-7 (On J22, FM input)	28480	1901-0179
DS1	1990-0858	6	1	LED-LAMP LUM-INT=150UCD IF=25MA MAX (On front panel Standby indicator)	28480	1990-0858
	1450-0615	9	1	LAMPHOLDER	28480	1450-0615
	08340-40002	9	1	LED MOUNT	28480	08340-40002
F1	2110-0002	9	1	FUSE 2A 250V NTD 1.25X 25 UL (For 240V operation)	75915	312002
F1	2110-0003	0	1	FUSE 3A 250V NTD 1.25X 25 UL (For 200V operation)	75915	312003
F1	2110-0010	9	1	FUSE 5A 250V NTD 1.25X 25 UL (For 100V operation)	75915	312005
F1	2110-0055	2	1	FUSE 4A 250V NTD 1.25X 25 UL (For 120V operation)	75915	312004
FL1	08340-60257	8	1	LINE MODULE-FILTERED REPLACEMENT KIT (Includes 2 metal retainers)	28480	08340-60257
J1				P/O J1W1		
J1W1	08340-60071	4	1	CABLE ASSY-COAX (SWP OUT)	28480	08340-60071
	0590-1251	6	4	NUT-SPCLY 15/32-32-THD 1-IN-THK 562-WD	00000	ORDER BY DESCRIPTION
	1250-0870	4	3	CONNECTOR-RF BNC FEM SGL-HOLE-RR 50-OHM	28480	1250-0870
J2				P/O J2W1		
J2W1	08340-60066	7	1	CABLE ASSY-COAX (PULSE)	28480	08340-60066
	0590-1251	6	1	NUT-SPCLY 15/32-32-THD 1-IN-THK 562-WD	00000	ORDER BY DESCRIPTION
	1250-0870	4	1	CONNECTOR-RF BNC FEM SGL-HOLE-RR 50-OHM	28480	1250-0870

Major Assemblies and Components Location

Table J-1. Miscellaneous Electrical Replaceable Parts

Reference Designation	HP Part Number	C D	Qty	Description	Mfr Code	Mfr Part Number
J3 J3W1	08340-60069 0590-1251 1250-0870	0 6 4	1	P/O J3W1 CABLE ASSY-COAX (AM) NUT-SPCLY 15/32-32-THD 1-IN-THK 562-WD CONNECTOR-RF BNC FEM SGL-HOLE-RR 50-OHM	28480 00000 28480	08340-60069 ORDER BY DESCRIPTION 1250-0870
J4 J4W1	08340-60068 00310-48801 0590-1251 0360-1158 1250-1091	9 0 6 5 3	1 2	P/O J4W1 CABLE ASSY-COAX (EXT INPUT) WASHER-SHOULDERED NUT-SPCLY 15/32-32-THD 1-IN-THK 562-WD LUG CONNECTOR-RF BNC FEM SGL-HOLE-RR 50-OHM	28480 28480 00000 28480 28480	08340-60068 00310-48801 ORDER BY DESCRIPTION 0360-1158 1250-1091
J5	5061-5316	6	1	RF OUTPUT CONNECTOR ASSEMBLY	28480	5061-1100
J6	1250-0083 0360-1632 2950-0001	1 0 8	8 4 2	CONNECTOR-RF BNC FEM SGL-HOLE-FR 50-OHM TERMINAL-SLDR LUG LK-MTG FOR-#3/8-SCR NUT-HEX-DBL-CHAM 3/8-32-THD 094-IN-THK	28480 28480 00000	1250-0083 0360-1632 ORDER BY DESCRIPTION
J7	1250-0083 0360-1632 2950-0001	1 0 8		CONNECTOR-RF BNC FEM SGL-HOLE-FR 50-OHM TERMINAL-SLDR LUG LK-MTG FOR-#3/8-SCR NUT-HEX-DBL-CHAM 3/8-32-THD 094-IN-THK	28480 28480 00000	1250-0083 0360-1632 ORDER BY DESCRIPTION
J7W1	08340-60070	3	1	CABLE ASSY-COAX (A62J8 TO R P J7)	28480	08340-60070
J8	1250-0102 2190-0068 2950-0054	5 5 1	3 3 3	CONNECTOR-RF BNC FEM SGL-HOLE-FR 50-OHM WASHER-LK INTL T 1/2 IN 505-IN-ID NUT-HEX-DBL-CHAM 1/2-28-THD 125-IN-THK	28480 28480 00000	1250-0102 2190-0068 ORDER BY DESCRIPTION
J8W1	08340-60086	1	1	CABLE ASSY-COAX (A29J5 TO R P J8)	28480	08340-60086
J9	1250-0102 2190-0068 2950-0054	5 5 1		CONNECTOR-RF BNC FEM SGL-HOLE-FR 50-OHM WASHER-LK INTL T 1/2 IN 505-IN-ID NUT-HEX-DBL-CHAM 1/2-28-THD 125-IN-THK	28480 28480 00000	1250-0102 2190-0068 ORDER BY DESCRIPTION
J9W1	08340-60089	4	1	CABLE ASSY-COAX (A51J1 TO R P J9)	28480	08340-60089
J10	1250-0102 2190-0068 2950-0054	5 5 1		CONNECTOR-RF BNC FEM SGL-HOLE-FR 50-OHM WASHER-LK INTL T 1/2 IN 505-IN-ID NUT-HEX-DBL-CHAM 1/2-28-THD 125-IN-THK	28480 28480 00000	1250-0102 2190-0068 ORDER BY DESCRIPTION
J10W1	08340-60085	0	1	CABLE ASSY-COAX (A29J1 TO R P J10)	28480	08340-60085
J11	1250-0083 2190-0016	1 3	4	CONNECTOR-RF BNC FEM SGL-HOLE-FR 50-OHM WASHER-LK INTL T 3/8 IN 377-IN-ID	28480 28480	1250-0083 2190-0016
J12	1250-0083 2190-0016	1 3		CONNECTOR-RF BNC FEM SGL-HOLE-FR 50-OHM WASHER-LK INTL T 3/8 IN 377-IN-ID	28480 28480	1250-0083 2190-0016
J13	1250-0083 0360-1632	1 0		CONNECTOR-RF BNC FEM SGL-HOLE-FR 50-OHM TERMINAL-SLDR LUG LK-MTG FOR-#3/8-SCR	28480 28480	1250-0083 0360-1632
J14	1250-0083 2190-0016	1 3		CONNECTOR-RF BNC FEM SGL-HOLE-FR 50-OHM WASHER-LK INTL T 3/8 IN 377-IN-ID	28480 28480	1250-0083 2190-0016
J15	1250-0083 2190-0016	1 3		CONNECTOR-RF BNC FEM SGL-HOLE-FR 50-OHM WASHER-LK INTL T 3/8 IN 377-IN-ID	28480 28480	1250-0083 2190-0016
J16	1250-0083 0360-1632	1 0		CONNECTOR-RF BNC FEM SGL-HOLE-FR 50-OHM TERMINAL-SLDR LUG LK-MTG FOR-#3/8-SCR	28480 28480	1250-0083 0360-1632
J17	1251-6781	0	1	CONNECTOR 3-PIN M CIRC AUDIO (Includes mounting hardware)	28480	1251-6781
J18	1251-0064 1251-2942	0 7	1 2	CONNECTOR 25-PIN F D SERIES MOUNTING HARDWARE KIT	28480 28480	1251-0064 1251-2942
J19	08340-60127 2190-0104 2950-0132	1 0 6	1 1 1	CONNECTOR-TYPE N (R P AUX OUT) WASHER-LK INTL T 7/16 IN 439-IN-ID NUT-HEX-DBL-CHAM 7/16-28-THD 094-IN-THK	28480 28480 00000	08340-60127 2190-0104 ORDER BY DESCRIPTION
J20				REFER TO OPTION 004 AND 005 LISTINGS		
J21 J21W1	8120-3653	9	1	P/O J21W1 CABLE ASSY-RIBBON (HP-IB) (Includes J21 and mounting hardware)	28480	8120-3653
J22	1250-1091 0360-1158 00310-48801 0590-1251	3 5 0 6	1 1 2 1	BODY-RF CONNECTOR BNC FEMALE, STRAIGHT TERMINAL-SLDR LUG PL-MTG 062-HOLE-DID WASHER-SHOULDERED INSULATING NUT-SPCLY 15/32-32-THD 1-IN-THK 562-WD	03316 05313 00000 00000	28JS124-1 5413-21 ORDER BY DESCRIPTION ORDER BY DESCRIPTION
RPG1	08340-60197	5	1	ROTARY PULSE GENERATOR REPLACEMENT KIT (Includes locking tangs, connector housing, nut and washer)	28480	08340-60197
S1 S2	3101-2193 3101-0163	5 5	1 1	SWITCH-TGL SUBMIN SPDT 2A 250VAC FREQUENCY STANDARD SWITCH KIT (Includes mounting hardware)	28480 28480	3101-2193 3101-0163

Miscellaneous Mechanical and Chassis Parts

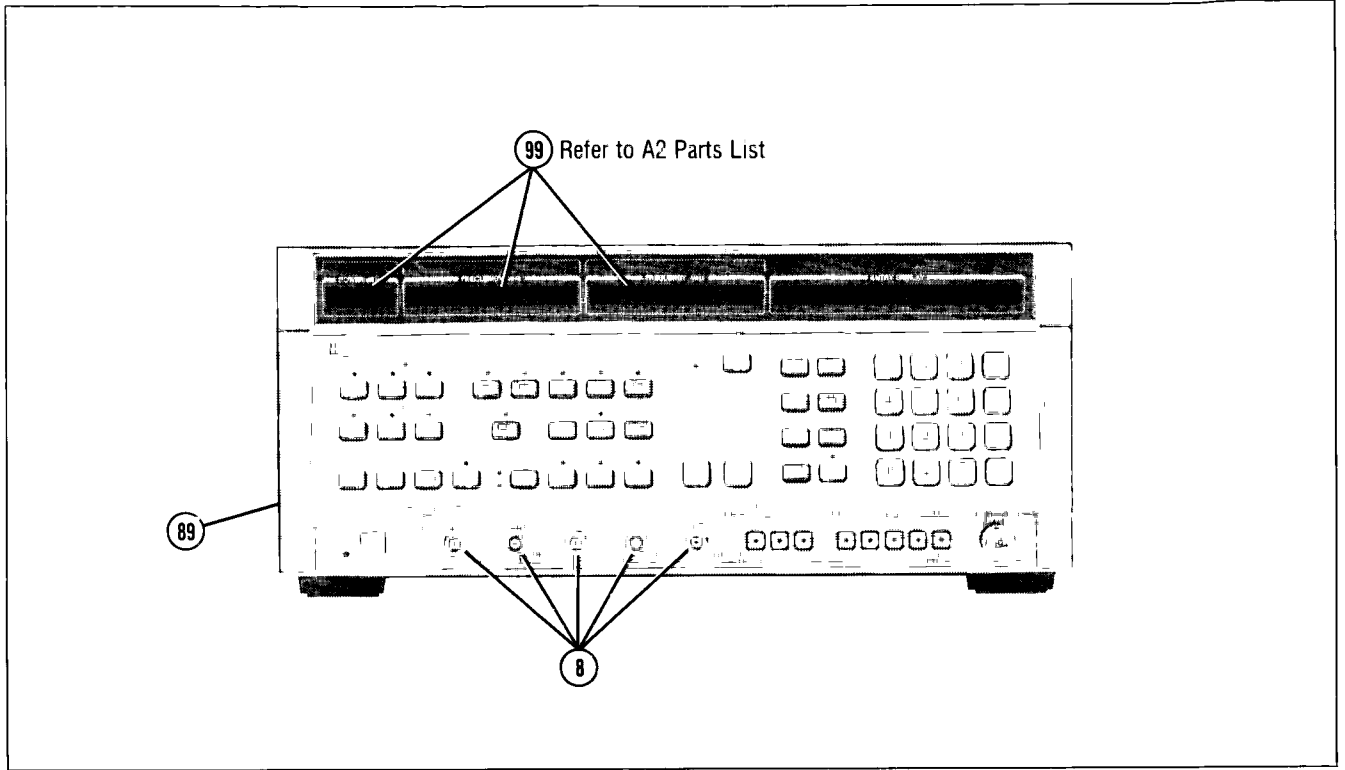

Figure J-5. Miscellaneous Mechanical & Chassis Parts (1 of 6)

Miscellaneous Mechanical and Chassis Parts

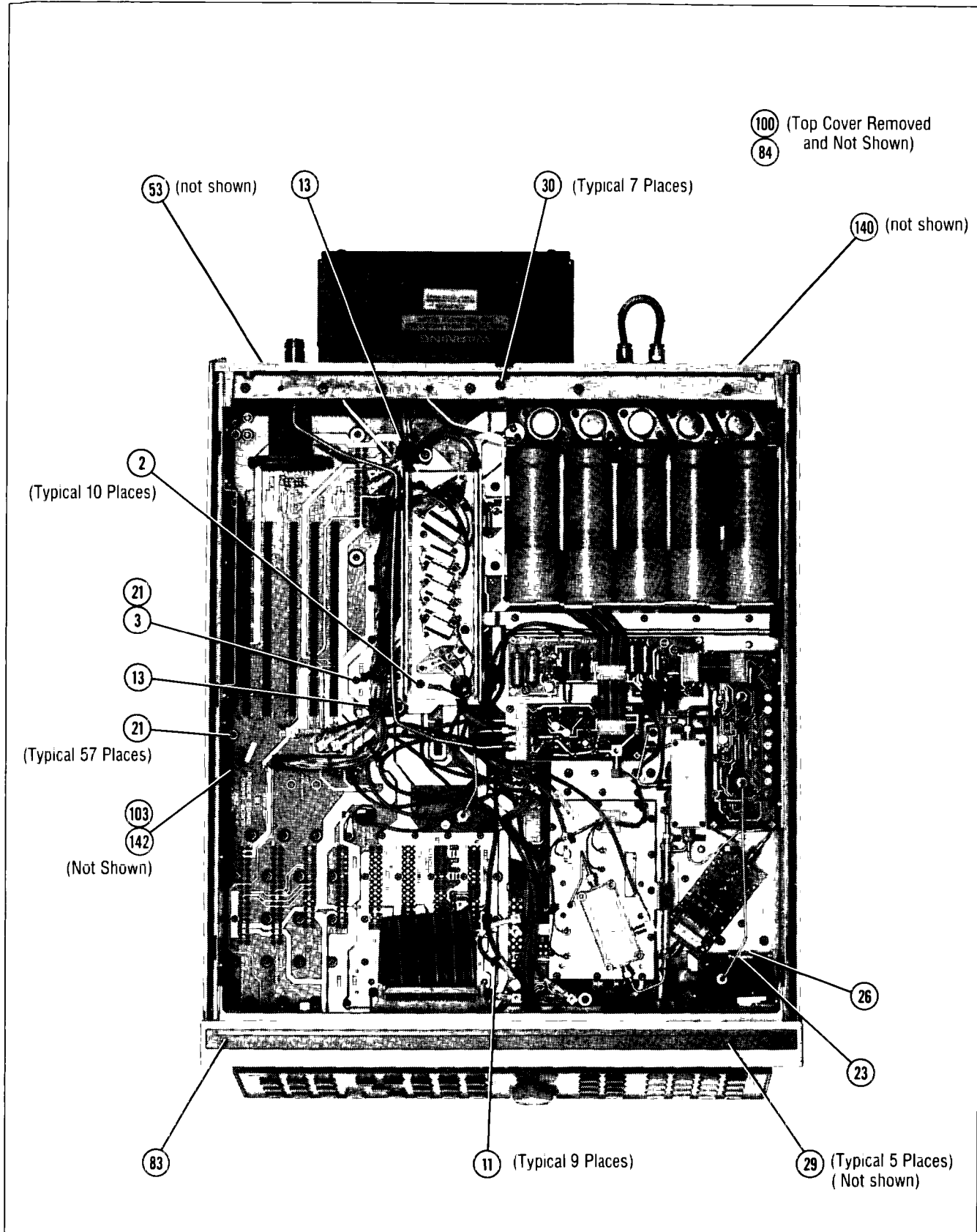

Figure J-5. Miscellaneous Mechanical & Chassis Parts (2 of 6)

Miscellaneous Mechanical and Chassis Parts

Table J-2. Miscellaneous Mechanical & Chassis Replaceable Parts

Reference Designation	HP Part Number	C D	Qty	Description	Mfr Code	Mfr Part Number
MISCELLANEOUS MECHANICAL & CHASSIS PARTS						
1	0340-0923	8	10	INSULATOR-BSHG NYLON	28480	0340-0923
2	0360-0037	7	10	TERMINAL-SLDR LUG PL-MTG FOR-#6-SCR	28480	0360-0037
3	0360-0042	4	3	TERMINAL-SLDR LUG PL-MTG FOR-#6-SCR	28480	0360-0042
4	0400-0082	8	2	GROMMET-CHAN NCH 09-IN-GRV-WD	28480	0400-0082
5	0400-0219	3	3	GROMMET-RND 5-IN-ID 093-IN-GRV-WD	28480	0400-0219
6	0520-0127	6	4	SCREW-MACH 2-56 188-IN-LG PAN-HD-POZI	00000	ORDER BY DESCRIPTION
7	0570-0632	3	10	SCREW-SPCL 4-40 312-IN-LG PAN-HD-POZI	00000	ORDER BY DESCRIPTION
8	0590-1251	6	4	NUT-HEX 15/32-32	00000	ORDER BY DESCRIPTION
9	1200-0043	8	5	INSULATOR-XSTR ALUMINUM	28480	1200-0043
10	1400-0031	8	3	CLAMP-CABLE 375-DIA 5-WD NYL	28480	1400-0031
11	1400-0249	0	9	CABLE TIE 062-625-DIA 091-WD NYL	06383	PLT1M-8
12	1400-0510	8	4	CLAMP-CABLE 15-DIA 62-WD NYL	28480	1400-0510
13	1400-0907	7	2	CLAMP-CABLE 187-DIA 5-WD FRD-NYLON	95987	3/16-HFR
14	1520-0205	2	3	SHOCK MOUNT 31 HGT	28480	1520-0205
15	2190-0003	8	14	WASHER-LK HLCL NO 4 .115-IN-ID	28480	2190-0003
16	2190-0006	1	15	WASHER-LK HLCL NO 6 141-IN-ID	28480	2190-0006
17	2190-0008	3	1	WASHER-LK EXT T NO 6 141-IN-ID	28480	2190-0008
18	2190-0011	8	6	WASHER-LK INTL T NO 10 195-IN-ID	28480	2190-0011
19	2190-0045	8	4	WASHER-LK HLCL NO 2 088-IN-ID	28480	2190-0045
20	2200-0103	2	4	SCREW-MACH 4-40 25-IN-LG PAN-HD-POZI	00000	ORDER BY DESCRIPTION
21	2200-0105	4	111	SCREW-MACH 4-40 312-IN-LG PAN-HD-POZI	00000	ORDER BY DESCRIPTION
22	2200-0107	6	1	SCREW-MACH 4-40 375-IN-LG PAN-HD-POZI	00000	ORDER BY DESCRIPTION
23	2200-0141	8	1	SCREW-MACH 4-40 312-IN-LG PAN-HD-POZI	00000	ORDER BY DESCRIPTION
24	2200-0149	6	10	SCREW-MACH 4-40 625-IN-LG PAN-HD-POZI	00000	ORDER BY DESCRIPTION
25	2200-0153	2	4	SCREW-MACH 4-40 875-IN-LG PAN-HD-POZI	00000	ORDER BY DESCRIPTION
26	2200-0166	7	3	SCREW-MACH 4-40 312-IN-LG 82 DEG	00000	ORDER BY DESCRIPTION
27	2360-0111	0	5	SCREW-MACH 6-32 188-IN-LG PAN-HD-POZI	00000	ORDER BY DESCRIPTION
28	2360-0113	2	13	SCREW-MACH 6-32 25-IN-LG PAN-HD-POZI	00000	ORDER BY DESCRIPTION
29	2360-0114	3	5	SCREW-MACH 6-32 25-IN-LG 82 DEG	00000	ORDER BY DESCRIPTION
30	2360-0115	4	34	SCREW-MACH 6-32 312-IN-LG PAN-HD-POZI	00000	ORDER BY DESCRIPTION
31	2360-0116	5	4	SCREW-MACH 6-32 312-IN-LG 82 DEG	00000	ORDER BY DESCRIPTION
32	2360-0117	6	10	SCREW-MACH 6-32 375-IN-LG PAN-HD-POZI	00000	ORDER BY DESCRIPTION
33	2360-0119	8	10	SCREW-MACH 6-32 438-IN-LG PAN-HD-POZI	00000	ORDER BY DESCRIPTION
34	2360-0122	3	1	SCREW-MACH 6-32 5-IN-LG 82 DEG	00000	ORDER BY DESCRIPTION
35	2360-0197	2	11	SCREW-MACH 6-32 375-IN-LG PAN-HD-POZI	00000	ORDER BY DESCRIPTION
35A	2360-0193	8	4	SCREW-MACH 6-32 25-IN-LG PAN-HD-POZI	00000	ORDER BY DESCRIPTION
36	2360-0331	6	9	SCREW-MACH 6-32 25-IN-LG PAN-HD-POZI	28480	2360-0331
37	2360-0333	8	26	SCREW-MACH 6-32 25-IN-LG 100 DEG	28480	2360-0333
38	2360-0334	9	9	SCREW-MACH 6-32 312-IN-LG 100 DEG	28480	2360-0334
39	2360-0360	1	2	SCREW-MACH 6-32 438-IN-LG 100 DEG	28480	2360-0360
40	2420-0002	6	2	NUT-HEX-DBL-CHAM 6-32-THD 109-IN-THK	28480	2420-0002
41	0515-1331	5	16	SCREW-MACH M4x0.7x6mm FH 90	28480	0515-1331
42	0515-0896	5	8	SCREW-MACH M4x0.7x10mm FH 90	28480	0515-0896
43	2680-0129	8	6	SCREW-MACH 10-32 312-IN-LG PAN-HD-POZI	00000	ORDER BY DESCRIPTION
44	3050-0066	8	2	WASHER-FL MTLC NO 6 147-IN-ID	28480	3050-0066
45	3050-0105	6	4	WASHER-FL MTLC NO 4 125-IN-ID	28480	3050-0105
46	3050-0227	3	7	WASHER-FL MTLC NO 6 149-IN-ID	28480	3050-0227
47	1250-0915	8	1	CONTACT-RF CONN SER APC-N FEMALE	9D949	131-149
48	1250-1577	0	1	CONNECTOR-RF FEMALE TYPE N	28480	1250-1577
49	2190-0104	0	1	WASHER-LK INTL T 7/16 IN 439-IN-ID	28480	2190-0104
50	2360-0115	4		SCREW-MACH 6-32 312-IN-LG PAN-HD-POZI	00000	ORDER BY DESCRIPTION
51	2950-0132	6	1	NUT-HEX-DBL-CHAM 7/16-28-THD 094-IN-THK	00000	ORDER BY DESCRIPTION
52	5040-0306	0	1	INSULATOR	28480	5040-0306
53	08340-00011	6	1	PANEL-REAR (AUX OUTPUT)	28480	08340-00011
54	08340-00056	9	1	DEFLECTOR-AIR	28480	08340-00056
55	08555-20093	5	1	CONTACT JACK	28480	08555-20093
56	08555-20094	6	1	BODY-BULK HEAD	28480	08555-20094
57	08761-2027	4	1	INSULATOR	28480	08761-2027
58	5021-5805	4	1	FRAME-FRONT (METRIC)	28480	5021-5805
59	08340-00076	3	1	CENTER DIVIDER	28480	08340-00076
60	08340-00002	5	1	CHASSIS-RF MOD (REAR)	28480	08340-00002
61	08340-00003	6	1	BRACKET-20-30 MOUNT	28480	08340-00003
62	08340-00004	7	1	BRACKET-MOUNT TRANS	28480	08340-00004
63	08340-00005	8	1	SUPPORT-MOM BOARD	28480	08340-00005
64	08340-00020	7	1	DIVIDER PROCESSOR	28480	08340-00020
65	08340-00029	6	1	GUIDE PLATE-PC BOARDS	28480	08340-00029

Miscellaneous Mechanical and Chassis Parts

Table J-2. Miscellaneous Mechanical & Chassis Replaceable Parts

Reference Designation	HP Part Number	C	D	Qty	Description	Mfr Code	Mfr Part Number
66	08340-00031	0		1	SUPPORT-PC PROCESSOR	28480	08340-00031
67	08340-20051	6		1	SUPPORT-REAR CENTER	28480	08340-20051
68	08340-20234	7		1	FRAME (REAR) MOD (METRIC)	28480	08340-20234
69	08340-20054	9		1	SUPPORT-FRONT CENTER DIVIDER	28480	08340-20054
70	08340-20056	1		1	GUIDE-POWER SUPPLY	28480	08340-20056
71	08340-20236	9		1	STRUT-CORNER (TOP) (METRIC)	28480	08340-20236
72	08340-20238	1		3	STRUT-CORNER MOD (METRIC)	28480	08340-20238
73	85660-00004	6		1	BRACKET-PIVOT PROCESSOR	28480	85660-00004
74	85660-20190	3		1	HOUSING-20-30 MHZ	28480	85660-20190
75	86701-20006	2		1	GUIDE-FRONT PC	28480	86701-20006
76	0360-0037	7		6	TERMINAL-SLDR LUG PL-MTG FOR-#6-SCR	28480	0360-0037
77	1251-4223	1		10	CONTACT-CONN U/W-POST-TYPE FEM CRP	28480	1251-4223
78	1251-6594	3		1	CONNECTOR HOUSING-5 FEMALE IR	28480	1251-6594
79	8120-0579	2		1	CABLE-SHLD 22AWG 5-CNDCT JGK-JKT	28480	8120-0579
80	8150-0005	2			WIRE 22AWG BK 300V PVC 7X30 105C	28480	8150-0005
81	5001-0440	1		2	TRIM-SIDE F F	28480	5001-0440
82	5040-7201	8		4	FOOT-BOTTOM	28480	5040-7201
83	5040-7202	9		1	TRIM STRIP (TOP)	28480	5040-7202
84	5061-9435	8		1	COVER FM TOP (METRIC)	28480	5061-9435
85	5061-9447	2		1	COVER FM BOTTOM (METRIC)	28480	5061-9447
86	5061-9462	1		1	COVER SIDE (METRIC)	28480	5061-9462
87	5061-9517	7		1	COVER FM PERFORATED (METRIC)	28480	5061-9517
88	5061-2033	8		1	INFO TRAY ASSY KIT	28480	5061-2033
89	08340-00086	5		1	DRESS PANEL-KEYBOARD	28480	08340-00086
90	08340-00074	1		1	HOLDER-PC COVER	28480	08340-00074
91	08340-00040	1		1	HOLDER-POWER SUPPLY BOARDS	28480	08340-00040
92	08340-00060	5		1	PLATE-CAP HOLDER	28480	08340-00060
93	08340-00061	6		1	HOLDER-CAP HOLDER	28480	08340-00061
94	08340-90246	8		1	INFO CARD #1	28480	08340-90246
95	08340-90247	9		1	INFO CARD #2	28480	08340-90247
96	85660-00025	1		1	SHOCK MOUNT (TOP)	28480	85660-00025
97	85660-00027	3		1	INSULATOR-HEAT SINK	28480	85660-00027
98	86701-00028	6		1	SPRING-FLAT	28480	86701-00028
99	1990-0720	1		1	DISPLAY-SPECIAL 1 HI	28480	1990-0720
100	8160-0226	0		12	RFI RND STR 050D	28480	8160-0226
101	08340-00006	9		1	SUPPORT-PC RECT	28480	08340-00006
102	08340-00008	1		1	CHASSIS RF MOD (FRONT)	28480	08340-00008
103	08340-00064	9		1	POCKET (Holds Cal. Constant Data)	28480	08340-00064
104	6960-0009	1		1	HOLE PLUG 531-D-HOLE	28480	6960-0009
105	0380-0644	4		2	STANDOFF-HEX 400-IN-LG 6-32 THD	28480	0380-0644
106	2200-0164	5		10	SCREW-MACH 4-40 188-IN-LG	28480	2200-0164
107	5021-3208	7		1	HOUSING-MACHINED	28480	5021-3208
108	86701-00029	7		1	BAFFLE-AIR TOP	28480	86701-00029
109	86701-00024	2		1	SCOOP-AIR	28480	86701-00024
110	86701-00030	0		1	BAFFLE-AIR BOTTOM	28480	86701-00030
111	08340-00067	2			COVER-RECT BOARD	28480	08340-00067
112	08340-00018	3			FAN FILTER	28480	08340-00018
113	08340-00017	2			GRILL-AIR	28480	08340-00017
114	3030-0152	1		2	SCREW-SET 4-40 312-IN-LG SMALL CUP PT	28480	3030-0152
115	08340-00016	1		1	FAN HOUSING-BOTTOM	28480	08340-00016
116	08340-00012	7		1	FAN HOUSING-TOP	28480	08340-00012
117	08340-00014	9			FAN GRILL HOUSING	28480	08340-00014
118	1520-0230	3		4	SHOCK MOUNT	28480	1520-0230
119	08340-00016	1		1	BASE PLATE-FAN	28480	08340-00016
120	85660-20092	4		4	RUBBER SHOCK MOUNT	28480	85660-20092
121	2360-0196	1		4	SCREW-MACH 6-32 375-IN-LG 100 DEG	28480	2360-0196
122	2190-0009	4		2	WASHER-LK INT T NO 8 168-IN-ID	28480	2190-0009
123	2510-0051	6		2	SCREW-MACH 8-32 625-IN-LG PAN-HD-POZI	28480	2510-0051
124	0360-0043	5			TERMINAL-SLDR LUG PL-MTG FOR-NO 6-SCR	28480	0360-0043
125	1251-6796	7			CONN-POST TYPE	28480	1251-6796
126	0360-1632	0		4	TERMINAL-SLDR LUG LK-MTG FOR-#3/8-SCR	28480	0360-1632
127	0362-0227	1		2	CONNECTOR-SGL CONT SKT 1 14-MM-BSC-SZ	28480	0362-0227
128	1250-0083	1		8	CONNECTOR-RF BNC FEM SGL-HOLE-FR 50-OHM	28480	1250-0083
129	1250-0102	5		3	CONNECTOR-RF BNC FEM SGL-HOLE-FR 50-OHM	28480	1250-0102
130	1251-0064	0		1	CONNECTOR 25-PIN F D SERIES	28480	1251-0064
131	1251-2942	7		2	CONNECTOR-RACK & PANEL LOCK	28480	1251-2942
132	1251-3653	9		26	CONNECTOR CONTACT FEMALE 025	28480	1251-3653
133	1251-6781	0		1	CONNECTOR RECEPTACLE 3 MALE CONTACT	28480	1251-6781
134	1251-7374	9		1	CONNECTOR HOUSING-28 FEMALE 2R	28480	1251-7374
135	2190-0016	3		4	WASHER-LK INTL T 3/8 IN 377-IN-ID	28480	2190-0016

Miscellaneous Mechanical and Chassis Parts

Table J-2. Miscellaneous Mechanical & Chassis Replaceable Parts

Reference Designation	HP Part Number	C D	Qty	Description	Mfr Code	Mfr Part Number
136	2190-0068	5	3	WASHER-LK INTL T 1/2 IN 505-IN-ID	28480	2190-0068
137	2190-0104	0	1	WASHER-LK INTL T 7/16 IN 439-IN-ID	28480	2190-0104
138	2950-0001	8	8	NUT-HEX-DBL-CHAM 3/8-32-THD 094-IN-THK	00000	ORDER BY DESCRIPTION
139	2950-0054	1	3	NUT-HEX-DBL-CHAM 1/2-28-THD 125-IN-THK	00000	ORDER BY DESCRIPTION
140	08340-00082	1	1	REAR PANEL	28480	08340-00082
141	3101-0163	5	1	SWITCH KIT	28480	3101-0163
142	9222-0090	9	1	PLASTIC JACKET (Holds Cal Constant Data)	28480	9222-0090
143	08340-00070	7	1	BRACKET	28480	08340-00070
144	08340-00089	4	1	A18 MOUNTING PLATE	28480	08340-00089
145	08340-00090	7	1	A16 MOUNTING PLATE	28480	08340-00090
146	08340-00079	6	1	A17 MOUNTING PLATE	28480	08340-00079
147	2200-0164	5	2	SCREW-MACH 4-40 188-IN-LG UNCT 82 DEG	00000	ORDER BY DESCRIPTION
148	2200-0165	6	5	SCREW-MACH 4-40 25-IN-LG 82 DEG	00000	ORDER BY DESCRIPTION

BACKDATING E (serial number prefix 2730A)

The following assemblies are different: A20 RF section filter, A21 pulse modulation and A62 motherboard.

Instructions

Replace the existing manual pages with the pages provided in this backdating subsection to reflect the instrument configuration.

Replace the following pages:

A62-5 through A62-32, Volume 1, section E – Motherboard Wiring List

A20-4 through A20-8, Volume 2, section H – RF Section

A21-1 through A21-10, Volume 2, section H – RF section

A62 Motherboard Component Level Troubleshooting

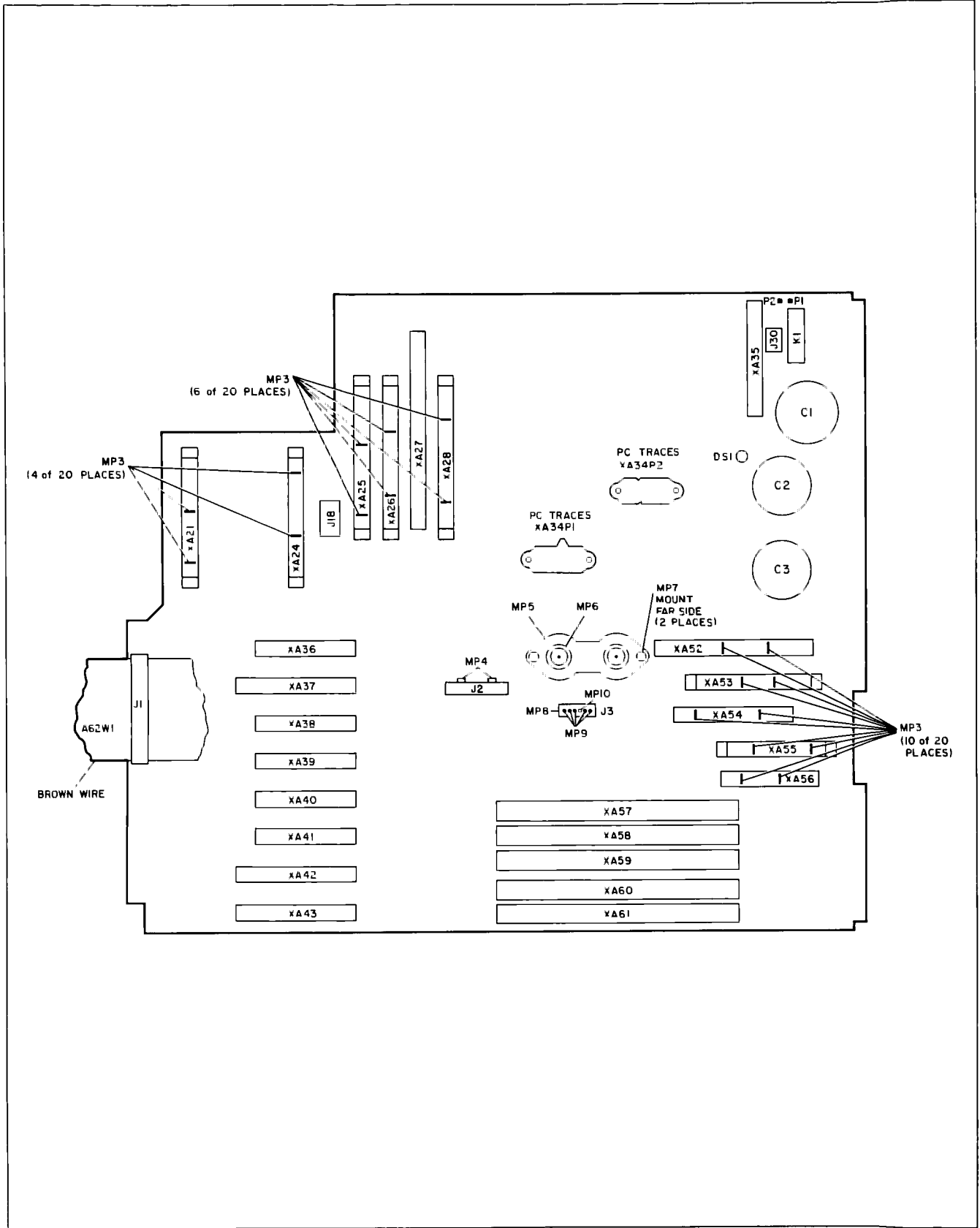

Figure A62-2. A62 Motherboard Component Location Diagram (1 of 2)

A62 MOTHERBOARD
SOLDER SIDE

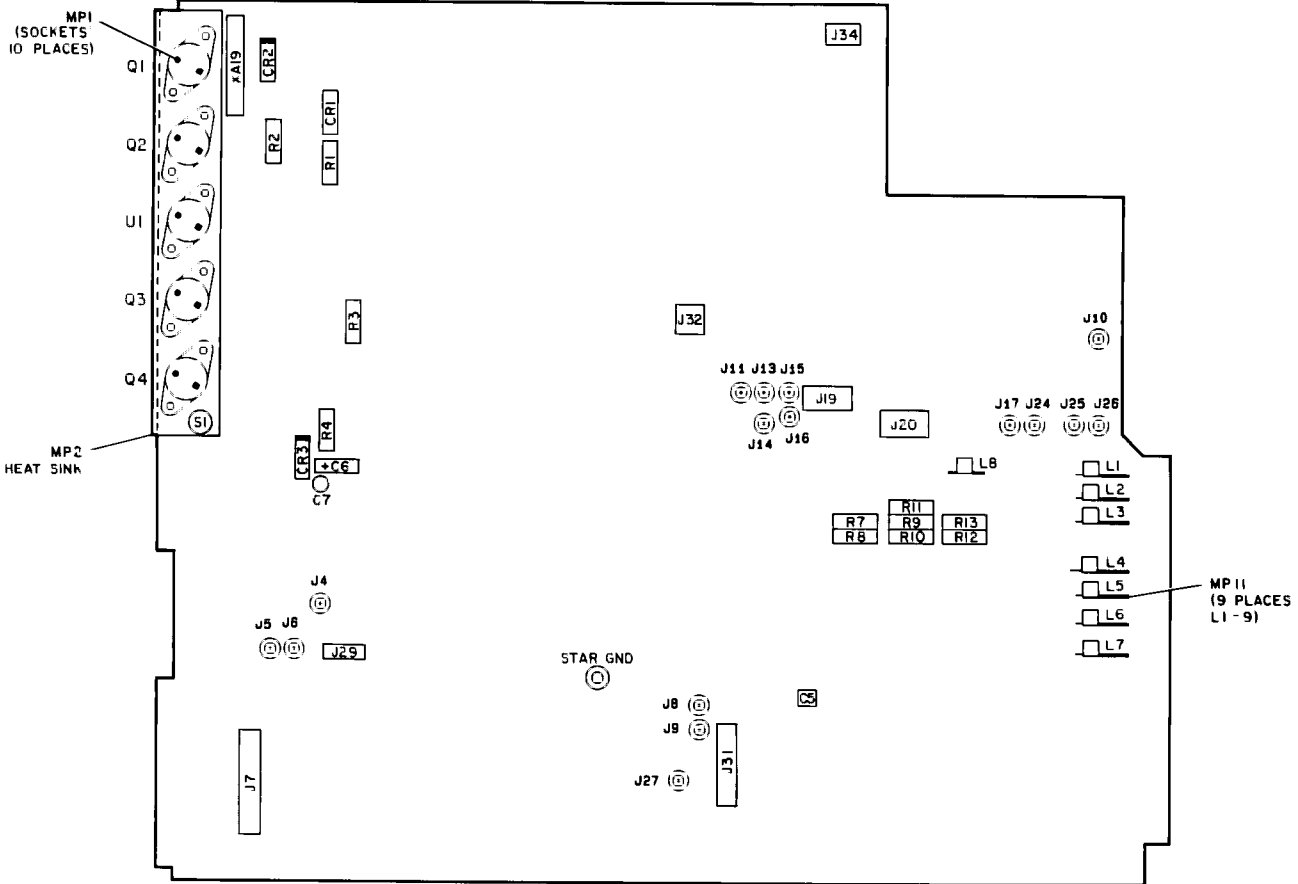

Figure A62-2. A62 Motherboard Component Location Diagram (2 of 2)

A62 Motherboard Component Level Troubleshooting

Table A62-1. Motherboard Wiring List

Mnemonic	Description	Type	Levels
ADR0 ADR1 ADR2 ADR3 ADR4	INSTRUMENT I/O ADDRESS BUS BIT 0 INSTRUMENT I/O ADDRESS BUS BIT 1 INSTRUMENT I/O ADDRESS BUS BIT 2 INSTRUMENT I/O ADDRESS BUS BIT 3 INSTRUMENT I/O ADDRESS BUS BIT 4	DIGITAL DIGITAL DIGITAL DIGITAL DIGITAL	TTL TTL TTL TTL TTL
AM IN AM RTN	AMPLITUDE MODULATION INPUT AMPLITUDE MODULATION GROUND RETURN	ANALOG GROUND	±IV MAX. 0V
ATN ATNAT1 ATNAT2 ATNAT3 ATNAT4 ATN COIL + ATNTH1 ATNTH2 ATNTH3 ATNTH4	IEEE 488 ATTENTION (ATN) ATTENUATOR ATTENUATION CARD 1 ATTENUATOR ATTENUATION CARD 2 ATTENUATOR ATTENUATION CARD 3 ATTENUATOR ATTENUATION CARD 4 ATTENUATOR SOLENOID COILS SUPPLY ATTENUATOR THROUGH CARD 1 ATTENUATOR THROUGH CARD 2 ATTENUATOR THROUGH CARD 3 ATTENUATOR THROUGH CARD 4	DIGITAL DIGITAL DIGITAL DIGITAL DIGITAL POWER SUPPLY DIGITAL DIGITAL DIGITAL DIGITAL	TTL OPEN COLLECTOR OPEN COLLECTOR OPEN COLLECTOR OPEN COLLECTOR +5V OPEN COLLECTOR OPEN COLLECTOR OPEN COLLECTOR OPEN COLLECTOR
BVSWP	BUFFERED 0 TO 10V SWEEP RAMP	ANALOG	10V/SWEEP
DAV	IEEE 488 DATA VALID (DAV)	DIGITAL	TTL
DB0 DB1 DB2 DB3 DB4 DB5	INSTRUMENT I/O DATA BUS BIT 0 INSTRUMENT I/O DATA BUS BIT 1 INSTRUMENT I/O DATA BUS BIT 2 INSTRUMENT I/O DATA BUS BIT 3 INSTRUMENT I/O DATA BUS BIT 4 INSTRUMENT I/O DATA BUS BIT 5	DIGITAL DIGITAL DIGITAL DIGITAL DIGITAL DIGITAL	TTL TTL TTL TTL TTL TTL

Table A62-1. Motherboard Wiring List

Mnemonic	Source	Destination
ADR0 ADR1 ADR2 ADR3 ADR4	XA60-17 XA60-73 XA60-18 XA60-74 XA60-19	XA27-9, XA57-17, XA58-17, XA59-17, A62J1-23 XA27-40, XA57-73, XA58-73, XA59-73, A62J1-24 XA27-10, XA57-18, XA58-18, XA59-18, A62J1-25 XA27-41, XA57-74, XA58-74, XA59-74, A62J1-26 XA27-11, XA57-19, XA58-19, XA59-19, A62J1-27
AM IN AM RTN	A62J15 CENTER A62J15 SHIELD ^a	XA26-19 XA26-41, A62 SMC SHIELD AND GUARD TRACE AROUND AM IN
ATN ATNAT1 ATNAT2 ATNAT3 ATNAT4 ATN COIL + ATNTH1 ATNTH2 ATNTH3 ATNTH4	XA60-8 XA24-30 XA24-29 XA24-28 XA24-27 XA24-7 XA24-12 XA24-11 XA24-10 XA24-9	A62J7-21 A62J20-2 A62J20-9 A62J20-5 A62J20-10 A62J20-6 A62J20-13 A62J20-3 A62J20-11 A62J20-4
BVSWP	XA58-40	XA27-31
DAV	XA60-6	A62J7-11
DB0 DB1 DB2 DB3 DB4 DB5	XA60-20 ^b XA60-76 ^b XA60-21 ^b XA60-77 ^b XA60-22 ^b XA60-78 ^b	XA21-10, XA23-9, XA26-15, XA27-22, XA28-11, XA37-1, XA42-21, XA43-21, XA57-20, XA58-20, XA59-20, XA61-20 ⁱ , A62J1-3 XA21-11, XA23-27, XA26-37, XA27-53, XA28-34, XA37-19, XA42-3, XA43-3, XA54-10, XA57-76, XA58-76, XA59-76, A62J1-4 XA23-10, XA26-16, XA27-23, XA28-12, XA37-2, XA42-22, XA43-22, XA54-29, XA57-21, XA58-21, XA59-21, A62J1-5 XA23-28, XA26-38, XA27-54, XA28-35, XA37-20, XA42-4, XA43-4, XA54-11, XA57-77, XA58-77, XA59-77, A62J1-6 XA21-12, XA23-11, XA26-17, XA27-24, XA28-13, XA37-3, XA42-23, XA43-23, XA54-30, XA57-22, XA58-22, XA59-22, A62J1-7 XA21-13, XA23-29, XA27-55, XA28-36, XA37-21, XA42-5, XA43-5, XA54-12, XA57-78, XA58-78, XA59-78, A62J1-8

^a Multiple sources

^b Open collector bus — multiple sources

ⁱ The A61 board assembly is not included with the HP 8340B. Traces connected to XA61 are included in this wiring list to keep signal destinations complete.

A62 Motherboard Component Level Troubleshooting

Table A62-1. Motherboard Wiring List

Mnemonic	Description	Type	Levels
DB6	INSTRUMENT I/O DATA BUS BIT 6	DIGITAL	TTL
DB7	INSTRUMENT I/O DATA BUS BIT 7	DIGITAL	TTL
DB8	INSTRUMENT I/O DATA BUS BIT 8	DIGITAL	TTL
DB9	INSTRUMENT I/O DATA BUS BIT 9	DIGITAL	TTL
DB10	INSTRUMENT I/O DATA BUS BIT 10	DIGITAL	TTL
DB11	INSTRUMENT I/O DATA BUS BIT 11	DIGITAL	TTL
DB12	INSTRUMENT I/O DATA BUS BIT 12	DIGITAL	TTL
DB13	INSTRUMENT I/O DATA BUS BIT 13	DIGITAL	TTL
DB14	INSTRUMENT I/O DATA BUS BIT 14	DIGITAL	TTL
DB15	INSTRUMENT I/O DATA BUS BIT 15	DIGITAL	TTL
DETLVL	DETECTED LEVEL INPUT TO A.D.C.	ANALOG	-0.2V/dB, 0V=0dB
DETOU	DETECTED LEVEL INPUT TO LINEAR MOD BOARD	ANALOG	-0.3VdB, 0V=0dB
DET S/H+	DETECTOR SAMPLE/HOLD CONTROL	DIGITAL	+4.5V/+3.5V
DET S/H-	DETECTOR SAMPLE/HOLD CONTROL	DIGITAL	+3.5V/+4.5V
DIV N2	500 KHZ DIVIDED OUTPUT FROM PLL2 DIVIDER	DIGITAL	TTL (LOW TRUE)
DIO1	IEEE 488 I/O DATA BUS BIT 1	DIGITAL	TTL
DIO2	IEEE 488 I/O DATA BUS BIT 2	DIGITAL	TTL
DIO3	IEEE 488 I/O DATA BUS BIT 3	DIGITAL	TTL
DIO4	IEEE 488 I/O DATA BUS BIT 4	DIGITAL	TTL
DIO5	IEEE 488 I/O DATA BUS BIT 5	DIGITAL	TTL
DIO6	IEEE 488 I/O DATA BUS BIT 6	DIGITAL	TTL
DIO7	IEEE 488 I/O DATA BUS BIT 7	DIGITAL	TTL
DIO8	IEEE 488 I/O DATA BUS BIT 8	DIGITAL	TTL
EOI	IEEE 488 END OR IDENTIFY (EOI)	DIGITAL	TTL
EXDET	EXTERNAL DETECTOR INPUT	ANALOG	0.5mV TO 2V
EXDETR	EXTERNAL DETECTOR INPUT GROUND RETURN	GROUND	0V

A62 Motherboard Component Level Troubleshooting

Table A62-1. Motherboard Wiring List

Mnemonic	Source	Destination
DB6	XA60-23 ^b	XA21-14, XA23-12, XA26-39, XA27-25, XA28-14, XA37-4, XA42-24, XA43-24, XA54-31, XA57-23, XA58-23, XA59-23, A62J1-9
DB7	XA60-79 ^b	XA21-15, XA23-30, XA26-40, XA27-56, XA28-37, XA37-22, XA42-6, XA43-6, XA54-13, XA57-79, XA58-79, XA59-79, A62J1-10
DB8	XA60-24 ^b	XA21-31, XA23-13, XA27-26, XA28-15, THRU A62R7 TO XA36-2, XA37-5, XA42-25, XA43-25, XA54-32, XA57-24, XA58-24, XA59-24, A62J1-11
DB9	XA60-80 ^b	XA23-31, XA24-14, XA27-57, XA28-38, THRU A62R8 TO XA36-17, XA37-23, XA42-7, XA43-7, XA54-14, XA57-80, XA58-80, XA59-80, A62J1-12
DB10	XA60-25 ^b	XA23-14, XA24-15, XA27-27, XA28-16, THRU A62R9 TO XA36-3, XA37-7, XA42-26, XA43-26, XA54-33, XA57-25, XA58-25, XA59-25, A62J1-13
DB11	XA60-81 ^b	XA21-32, XA24-32, XA26-35, XA27-58, THRU A62R10 TO XA36-18, XA37-25, XA42-8, XA43-8, XA54-15, XA57-81, XA58-81, XA59-81, A62J1-14
DB12	XA60-26 ^b	XA24-16, XA54-34, XA57-26, XA58-26, XA59-26, A62J1-15
DB13	XA60-82 ^b	XA24-34, XA54-16, XA57-82, XA58-82, XA59-82, A62J1-16
DB14	XA60-27 ^b	XA54-35, XA57-27, XA58-27, XA59-27, A62J1-17
DB15	XA60-83 ^b	XA54-17, XA57-83, XA58-83, XA59-83, A62J1-18
DETLVL	XA25-33	XA27-29
DETOUT	XA25-32	XA26-10
DET S/H+	XA21-3	XA25-2
DET S/H-	XA21-21	XA25-24
DIV N2	XA42-27	XA41-19
DIO1	XA60-57	XA59-57, A62J7-1
DIO2	XA60-58	XA59-58, A62J7-3
DIO3	XA60-59	XA59-59, A62J7-5
DIO4	XA60-60	XA59-60, A62J7-7
DIO5	XA60-61	XA59-61, A62J7-2
DIO6	XA60-62	XA59-62, A62J7-4
DIO7	XA60-63	XA59-63, A62J7-6
DIO8	XA60-64	XA59-64, A62J7-8
EOI	XA60-7	XA59-7, A62J7-9
EXDET	A62J16 CENTER	XA25-44
EXDETR	A62J16 SHIELD ^a	XA25-43, GUARD TRACE AROUND EXDET

^a Multiple sources.

^b Open collector bus.

A62 Motherboard Component Level Troubleshooting

Table A62-1. Motherboard Wiring List

Mnemonic	Description	Type	Levels
EXT TRIG	EXTERNAL TRIGGER INPUT	TTL/ANALOG	EXT SOURCE LVL
FAN1	SWITCHED FAN POWER	AC LINE	110 VAC
FAN2	SWITCHED FAN POWER	AC LINE	110 VAC
FAN3	PRIMARY FAN POWER	AC LINE	110 VAC
FAN4	PRIMARY FAN POWER	AC LINE	110 VAC
FM OUT	FREQUENCY MODULATOR OUTPUT	ANALOG	
FM DRVR SHIELD	FREQUENCY MODULATOR OUTPUT SHIELD	GROUND	0V
FM INPUT	FREQUENCY MODULATOR INPUT	ANALOG	-8V TO +8V
FM SHIELD	FREQUENCY MODULATOR INPUT SHIELD	GROUND	0V
FPNSWP FPNSWP RTN	FRONT PANEL SWEEP RAMP FRONT PANEL SWEEP RAMP GROUND RETURN	ANALOG GROUND	10V/SWEEP 0V
GND	ANALOG GROUND	GROUND	0V
GND HPIB	IEEE 488 GROUND	GROUND	0V
GND PLANE	DIGITAL GROUND	GROUND	0V

A62 Motherboard Component Level Troubleshooting

Table A62-1. Motherboard Wiring List

Mnemonic	Source	Destination
EXT TRIG	A62J31-4,22	XA57-106
FAN1 FAN2 FAN3 FAN4	A62K1-7 A62K1-10 A62P2 (SOLDER PAD) A62P1 (SOLDER PAD)	A62J30-3 A62J30-1 A62K1-5 A62K1-14, A62XA35
FM OUT	XA23-16	THRU A62J24 SMC CENTER TO A44J3
FM DRVR SHIELD	XA23-34	A62J24 SMC SHIELD
FM INPUT	XA23-18	A62J17 SMC CENTER
FM SHIELD	XA23-17	A62J17 SMC SHIELD
FPNLSWP FPNLSWP RTN	XA57-43 XA57-99	A62J9 SMC CENTER GUARD TRACE AROUND FPNLSWP, A62J9 SMC SHIELD
GND	NOTES ^{c,d,e,f}	XA19-10, 22, XA21-8, 26, XA22-5, 6, 23, 24 ^g , XA23-8, 26, XA24-8, XA25-9, 10, 31, XA26-6, 28, XA27-6, 37, XA28-6, 28, XA34P2-10, 11, XA35-4, 22, XA36-1, 5, 6, 7, 8, 10, 11, 14, 16, 19, 20, 21, 22, 26, 29, XA37-6, 9, 10, 13 THRU 17, 24, 27 THRU 35, XA38-1 THRU 11, 14 THRU 26, 29, 30, XA39-2 THRU 11, 13, 14, 17 THRU 26, 28, 29, XA40-2 THRU 6, 10, 14, 17, 21, 25, 29, XA41-1, 3, 6, 10, 11, 14, 16, 18, 21, 22, 25, 26, 29, XA42-10, 17, 20, 28, 35, XA43-11, 12, 13, 14, 17, 27, 29, 35, XA52-19, 43, XA53-14, 15, 16, 33, 34, 35, XA54-5, 23, XA55-5, 6, 20, 21, XA56-5, 20, A62J2-2, 19, A62J3-2, 4, A62J23 SHIELD, A62C2(—), A62C3(—), A62C5, A62C6(—), A62C7(—), A62R3, A62R14, CHASSIS, A62DS1 CATHODE M/N ASSY GND PLANE, T1 WHITE WIRE, ALL GROUNDS CONNECT TO THE 20/30 CASTING GND PLANE GROUNDED TO THE CHASSIS BY THE CASTING AND TO STAR GROUND
GND HPIB GND PLANE	CONNECTED TO REAR PANEL GND ^h	A62J7-12, 14, 16, 18, 20, 22, 23, 24 (NO CONNECTION — THESE ARE GROUNDED AT THE REAR PANEL) XA22-14, 32 ^g , XA23-6, 24, XA24-26, XA27-7, 19, 38, 50, XA57-1, 29, 30, 31, 34, 40, 55, 56, 70, 71, 72, 75, 84, 85, 86, 89, 110, XA58-1, 34, 44, 45, 46, 55, 56, 70, 71, 75, 89, 99, 101, 55, 110, XA59-1, 40 THRU 44, 55, 56, 75, 96, 97, 110, XA60-1, 40 THRU 44, 55, 56, 70, 71, 72, 75, 96 THRU 100, 110, XA61-1, 34, 40, 41, 42, 43, 44, 55, 56, 70, 71, 72, 75, 89, 96, 97, 98, 99, 100, 110 ⁱ , A62J1-1, 21, 29, 38, 39, 40, 41, 46, 48, 50, A62J20-1, A62J31-12, 35, A62J35-10, A62J19-1, 9, GND PLANE NEAR RF SECTION

- ^c M/N assembly ground plane connected to Star Ground through W45.
- ^d 20/30 loops casting.
- ^e Star Ground connected to A47W3, and also to the M/N assembly ground plane through W45.
- ^f Ground is connected to the chassis
- ^g Reserved for future expansion.
- ^h Ground Plane is located near the RF Section.
- ⁱ The A61 board assembly is not included with the HP 8340B. Traces connected to XA61 are included in this wiring list to keep signal destinations complete.

A62 Motherboard Component Level Troubleshooting

Table A62-1. Motherboard Wiring List

Mnemonic	Description	Type	Levels
HADCEN HCEN HENDKICK HFILYO HINT HIPMOD DRV HLBW	A.D.C. CONVERT ENABLE YO DELAY COMPENSATION ENABLE YO AND YTM KICK PULSE COMPLETE FILTER YO ENABLE INTERNAL/EXTERNAL LEVELING CONTROL HIGH BAND PULSE MODULATOR DRIVE ALC LOOP BAND WIDTH CONTROL	DIGITAL DIGITAL DIGITAL DIGITAL DIGITAL ANALOG DIGITAL	TTL (HIGH TRUE) TTL (HIGH TRUE) TTL (HIGH TRUE) TTL (HIGH TRUE) TTL (HIGH TRUE) PIN DIODE CURRENT TTL (HIGH TRUE)
HLB0 HLB1 HLB2	ENCODED BAND INFO BIT 0 ENCODED BAND INFO BIT 1 ENCODED BAND INFO BIT 2	DIGITAL DIGITAL DIGITAL	TTL (HIGH TRUE) TTL (HIGH TRUE) TTL (HIGH TRUE)
HLEY HLE2	LOCK ENABLE FOR YO LOOP LOCK ENABLE TO PLL2	DIGITAL DIGITAL	TTL (HIGH TRUE) TTL (HIGH TRUE)
HMRKR HMTR HNUP HOVC HPLSEN	MARKER ASSERTED EXTERNAL METER LEVELING CONTROL NEGATIVE POWER SUPPLIED UP SIGNAL INTERNAL 10 MHZ STANDARD TEMP ERROR PULSE MODULATION ENABLED	DIGITAL DIGITAL DIGITAL ANALOG DIGITAL	TTL (HIGH TRUE) TTL (HIGH TRUE) TTL (HIGH TRUE) +3V - OVEN WARM TTL L(HIGH TRUE)
HPUP HRFON HSP HSTD	POSITIVE POWER SUPPLIES UP SIGNAL RF OUTPUT POWER ON SWEEP IN PROGRESS INTERNAL 10 MHZ STANDARD ENABLE	DIGITAL DIGITAL DIGITAL DIGITAL	TTL (HIGH TRUE) TTL (HIGH TRUE) TTL (HIGH TRUE) TTL (HIGH TRUE)
HULH HULM HULR HULY HUL1 HUL2	3.7 GHZ OSCILLATOR UNLOCKED M/N OSCILLATOR UNLOCKED REFERENCE OSCILLATOR UNLOCKED YO 2-7 GHZ OSCILLATOR UNLOCKED PLL1 OSCILLATOR UNLOCKED PLL2 OSCILLATOR UNLOCKED	DIGITAL DIGITAL DIGITAL DIGITAL DIGITAL DIGITAL	TTL (HIGH TRUE) TTL (HIGH TRUE) TTL (HIGH TRUE) TTL (HIGH TRUE) TTL (HIGH TRUE) TTL (HIGH TRUE)

Table A62-1. Motherboard Wiring List

Mnemonic	Source	Destination
HADCEN HCEN HENDKICK HFILYO HINT HIPMOD DRV HLBW	XA21-1 XA59-67 XA28-18 XA59-47,72 XA26-42 XA21-36 XA26-33	XA27-8 XA55-14 XA24-31 XA58-72, A62J2-5 XA21-28, XA25-42 A62J25 SMC CENTER XA21-6, XA25-11
HLB0 HLB1 HLB2	XA27-46 XA27-16 XA27-47	XA24-20, XA26-29, XA28-31 XA24-21, XA26-30, XA28-32 XA24-22, XA26-31, XA28-33
HLEY HLE2	XA59-51 XA59-53	A62J2-3 XA41-2, XA42-2, XA43-2
HMRKR HMTR HNUP HOVC HPLSEN	XA57-2,12 XA26-13 XA53-17, XA56-1,16 A62J3-3 XA26-2	XA26-43 XA21-20, XA25-36 XA52-44 XA59-10, XA61-85 ¹ XA21-9, XA25-3
HPUP HRFON HSP HSTD	XA52-46 XA57-105 XA57-13 XA59-66	XA59-95, XA60-95, XA61-95 ¹ , A62J1-22 XA21-27, XA26-24 XA26-7, XA28-26, XA55-22, XA58-13, XA59-13, A62J2-14 XA52-21
HULH HULM HULR HULY HUL1 HUL2	A62J19-16 XA34P1-8 XA34P2-14 A62J2-16 XA37-26, XA39-1,16 XA41-4	XA57-49,104, XA59-105 XA59-104 XA59-49 XA59-50 XA59-106 XA59-107

¹ The A61 board assembly is not included with the HP 8340B. Traces connected to XA61 are included in this wiring list to keep signal destinations complete.

A62 Motherboard Component Level Troubleshooting

Table A62-1. Motherboard Wiring List

Mnemonic	Description	Type	Levels
HXREF IFC	EXTERNAL REFERENCE ENABLE IEEE 488 INTERFACE CLEAR (IFC)	DIGITAL DIGITAL	TTL (HIGH TRUE) TTL (LOW TRUE)
L ADR HOLD LALTEN LALTSEL LATTN LBX LCHNG	(USED FOR FACTORY PROGRAMMING ONLY) ALTERNATE MODE ENABLED CURRENT INST. STATE (FORE/BACK GROUND) ATTENUATOR INSTALLED SENSING BAND CROSS INSTRUMENT STATE CHANGED	DIGITAL DIGITAL DIGITAL DIGITAL DIGITAL DIG OPEN COLL	TTL (LOW TRUE) TTL (LOW TRUE) TTL (LOW TRUE) TTL (LOW TRUE) TTL (LOW TRUE) TTL (LOW TRUE)
LCK1 LCK2 LCK3 LCK4	DATA STROBE TO PLL2 COUNTERS (0, R2) DATA STROBE TO PLL2 DIR. DIVIDER (0, R0) DATA STROBE TO PLL2 PRETUNE DAC (0, R1) DATA STROBE TO PLL1 VCO GAIN SWITCH (0, R3)	DIGITAL DIGITAL DIGITAL DIGITAL	TTL (LOW TRUE) TTL (LOW TRUE) TTL (LOW TRUE) TTL (LOW TRUE)
LDETBW LHET LHIBND LHSOT LHSOT RTN	DETECTOR LOW BAND WIDTH CONTROL HETRODYNE BAND ENABLED FUNDAMENTAL OR MULTIPLIED BAND ENABLED HEAT SINK OVER TEMPERATURE SENSOR HEAT SINK OVER-TEMP SENSOR BND RETURN	DIGITAL DIGITAL DIGITAL DIGITAL GROUND	TTL (LOW TRUE) TTL (LOW TRUE) TTL (LOW TRUE) TTL (LOW TRUE) 0V
LINE TRIG	LINE TRIGGER SENSING 5V SECONDARY	RECTIFIED AC	LINE FREQ 7V TO -10V
LIPS LKICKYO LMNE LMODHLD LOMD LOPMOD DRV	INSTRUMENT - PRESET LOW KICK PULSE M/N OSCILLATOR LOCK ENABLED LINEAR MODULATOR SAMPLE/HOLD OVER-MODULATION DETECTED LOW BAND PULSE MODULATOR DRIVE	DIG. OPEN COLL ANALOG DIGITAL DIGITAL DIG. OPEN COLL ANALOG	TTL (LOW TRUE) 0 TO +5V TTL (LOW TRUE) TTL TTL (LOW TRUE) CURRENT SOURCE
LPROG	(USED FOR FACTORY PROGRAMMING ONLY)	DIGITAL	TTL (LOW TRUE)

A62 Motherboard Component Level Troubleshooting

Table A62-1. Motherboard Wiring List

Mnemonic	Source	Destination
HXREF IFC	A62J31-21 A62J7-17	XA58-108, XA59-98 XA60-3
L ADR HOLD LALTEN LALTSEL LATTN LBX LCHNG	XA60-45 XA57-60 XA57-59 A62J20-14 XA57-69, XA58-69, XA59-69 NOTE ^b	XA61-45 ⁱ A62J31-9,27 A62J31-10,28 XA27-39 XA27-21, XA58-100, XA59-45
LCK1 LCK2 LCK3 LCK4	XA59-54 XA59-109 XA59-108 XA59-52	XA42-19 XA42-1 XA43-19 THRU A62R11 TO XA36-4, XA37-8
LDETBW LHET LHIBND LHSOT LHSOT RTN	XA26-9 XA27-20 XA26-23 A62J31-30 A62J31-12	XA25-39, A62J34-2 XA21-29, XA25-37, A62J19-7.8 A62J19-15 XA52-12 GND PLANE
LINE TRIG	A62CR1 CATHODE	XA57-57,68, THRU A62R1 TO PWR ON LED
LIPS LKICKYO LMNE LMODHLD LOMD LOPMOD DRV	XA52-36, A62J1-19 XA54-19 XA59-86 XA21-2 XA26-8, A62J2-7 XA21-16	XA57-14, XA58-14, XA59-14, XA60-14, XA61-14 ⁱ XA55-1 XA34P1-2 XA26-1 XA27-48 A62J10 SMC CENTER
LPROG	XA60-101	XA61-101 ⁱ

^b Open collector bus – multiple sources.

ⁱ The A61 board assembly is not included with the HP 8340B. Traces connected to XA61 are included in this wiring list to keep signal destinations complete.

A62 Motherboard Component Level Troubleshooting

Table A62-1. Motherboard Wiring List

Mnemonic	Description	Type	Levels
LRETRACE LRSP LSBY LSPLD	RETRACE RESET SWEEP CONTROL STANDBY CONTROL SWEEP L E D. CONTROL OFF/ON	DIGITAL DIGITAL DIGITAL DIGITAL	TTL (LOW TRUE) TTL (LOW TRUE) 0V TO +22V TTL
LSSP LSRQ LSTEPUP LSTP LUNLVL	STEP SWEEP SERVICE REQUEST STEP UP FOR EXTERNAL FOOT SWITCH PROCESSOR STOPPED INSTRUMENT UNLEVELED	DIG. OPEN COLL. DIG. OPEN COLL. DIGITAL DIGITAL DIG. OPEN COLL.	TTL (LOW TRUE) TTL (LOW TRUE) TTL (LOW TRUE) TTL (LOW TRUE) TTL (LOW TRUE)
LVLCOR LVLREF LVSX LYOKICK LYSP	LEVELING CORRECTION A.L.C. LEVEL REFERENCE DISABLE YO SWEEPS YO SWEEP	ANALOG ANALOG DIGITAL DIGITAL	1.25 dB/V 0V=0dB .2V/dB 0V=0dBm TTL (LOW TRUE) TTL (LOW TRUE)
MKR RMP	SWEEP RAMP TO MARKER BANDCROSS BOARD	ANALOG	0 TO 10V/SWEEP
MOD RTN	ALC MODULATORS GROUND RETURN	GROUND	0V
MODHI MODLO MODLVL	HIGH BAND MODULATOR DRIVE LOW BAND MODULATOR DRIVE MODULATOR LEVEL	ANALOG ANALOG ANALOG	CURRENT SOURCE CURRENT SOURCE 0 TO -3 LEVELED
MUTE	PLOTTER MUTE CONTROL	DIGITAL	TTL (HIGH TRUE)
M1 M2 M3 M4 M5	M NUMBER TO M/N OSCILLATOR BIT 1 M NUMBER TO M/N OSCILLATOR BIT 2 M NUMBER TO M/N OSCILLATOR BIT 3 M NUMBER TO M/N OSCILLATOR BIT 4 M NUMBER TO M/N OSCILLATOR BIT 5	DIGITAL DIGITAL DIGITAL DIGITAL DIGITAL	TTL (HIGH TRUE) TTL (HIGH TRUE) TTL (HIGH TRUE) TTL (HIGH TRUE) TTL (HIGH TRUE)

Table A62-1. Motherboard Wiring List

Mnemonic	Source	Destination
LRETRACE LRSP LSBY LSPLD	XA57-58 XA59-85 A62J1-20 XA58-67	A62J31-11,29 XA58-85 XA52-45, A62CR2 ANODE A62J1-44
LSSP LSRQ LSTEPUP LSTP LUNLVL	XA57-107 NOTE ^b A62J31-14 XA59-65 XA26-36	A62J31-5,23 XA57-54, XA58-54, XA59-89, XA60-89, A62J1-45 A62J1-28 XA60-65, A62J1-43 XA27-52
LVLCOR LVLREF LVSX LYOKICK LYSP	XA25-14 XA27-30 XA58-68 XA54-21 XA59-11	XA27-62 XA25-13 XA54-9 XA28-41 XA55-7
MKR RMP	XA58-96	XA57-96
MOD RTN	XA26-21	A62J13 SMC SHIELD, A62J14 SMC SHIELD, GUARD TRACE AROUND MODHI AND MODLO
MODHI MODLO MODLVL	XA26-20 XA26-22 XA26-32	A62J13 SMC CENTER A62J14 SMC CENTER XA27-61
MUTE	XA57-61	A62J31-8,26
M1 M2 M3 M4 M5	XA59-33 XA59-88 XA59-32 XA59-87 XA59-31	XA34P1-5 XA34P1-6 XA34P1-3 XA34P1-4 XA34P1-1

^b Open collector bus – multiple sources.

A62 Motherboard Component Level Troubleshooting

Table A62-1. Motherboard Wiring List

Mnemonic	Description	Type	Levels
NDAC NEG BLANK NRFD	IEEE 488 NOT DATA ACCEPTED (NDAC) NEGATIVE BLANKING SIGNAL IEEE 488 NOT READY FOR DATA (NRFD)	DIGITAL DIGITAL DIGITAL	TTL 0, -5V TTL
N1 N2	N NUMBER TO M/N OSCILLATOR BIT 1 N NUMBER TO M/N OSCILLATOR BIT 2	DIGITAL DIGITAL	TTL TTL
N2 TUNE N2 TUNE RTN	TUNING SIGNAL TO PLL2 VCO GROUND RETURN	ANALOG GROUND	0V TO +7V 0V
N3 N4 N5 N6	N NUMBER TO M/N OSCILLATOR BIT 3 N NUMBER TO M/N OSCILLATOR BIT 4 N NUMBER TO M/N OSCILLATOR BIT 5 N NUMBER TO M/N OSCILLATOR BIT 6	DIGITAL DIGITAL DIGITAL DIGITAL	TTL TTL TTL TTL
PEN LIFT PEN LIFT RTN	PLOTTER PEN LIFT PLOTTER PEN LIFT GROUND RETURN	OPEN COLLECTOR GROUND	CLAMP AT 56 V 0V
PH1	PLL1 PHASE DETECTOR OUTPUT	ANALOG	0V TO +5V
PH2	PLL1 PHASE DETECTOR OUTPUT	ANALOG	0V TO +5V
PINBIAS PLS IN PLS IN RTN	SYTM P.I.N. DIODE BIAS EXTERNAL PULSE INPUT EXTERNAL PULSE GROUND RETURN	DIGITAL DIGITAL GROUND	-4V TO +12V TTL 0V
PMOD RTN	PULSE MODULATOR DRIVE GROUND RETURN	GROUND	0V
PRETUNE	YO PRETUNE	ANALOG	-2.5V/GHz 0 \cong 2GHz
PWR ON LED	+5 Vac THROUGH CR1 AND R1 TO DSI	POWER SUPPLY	+ .78V ANODE - ON
Q1B Q1E	TRANSISTOR Q1 BASE TRANSISTOR Q1 EMITTER	ANALOG ANALOG	

A62 Motherboard Component Level Troubleshooting

Table A62-1. Motherboard Wiring List

Mnemonic	Source	Destination
NDAC NEG BLANK NRFD	XA60-4 XA57-41 XA60-5	A62J7-15 A62J31-1,19 A62J7-13
N1 N2	XA59-48 XA59-103	XA34P1-15 XA34P1-14
N2 TUNE N2 TUNE RTN	XA41-23 XA41-8	XA43-28 XA43-10
N3 N4 N5 N6	XA59-47 XA59-102 XA59-46 XA59-101	XA34P1-13 XA34P1-12 XA34P1-11 XA34P1-10
PEN LIFT PEN LIFT RTN	XA57-108 XA57-109	A62J31-6,24 A62J31-25
PH1	A62R12	XA36-24, THRU A62R12 TO XA37-11
PH2	A62R13	XA36-25, THRU A62R13 TO XA37-12
PINBIAS PLS IN PLS IN RTN	XA24-24 A62J26 CENTER NOTE ^a	A62J18-10 XA21-18 XA21-17, GUARD TRACE AROUND PLS IN, A62J26 SMC SHIELD
PMOD RTN	XA21-35	GUARD TRACE AROUND HIPMOD AND LOPMOD DRV, A62J25 SMC SHIELD, A62J10 SMC SHIELD
PRETUNE	XA54-24	XA55-8,23, A62J5 SMC CENTER THRU COAX TO A62J11 SMC CENTER, XA28-22
PWR ON LED	A62R1	A62DS1 ANODE, THRU A62R1 TO LINE TRIG
Q1B Q1E	XA53-4 XA53-7,8,25,26	Q1 BASE Q1 EMITTER

^a Multiple sources.

A62 Motherboard Component Level Troubleshooting

Table A62-1. Motherboard Wiring List

Mnemonic	Description	Type	Levels
Q2B Q2E Q3B Q3C Q3E Q4B	TRANSISTOR Q2 BASE TRANSISTOR Q2 EMITTER TRANSISTOR Q3 BASE TRANSISTOR Q3 COLLECTOR TRANSISTOR Q3 EMMITER TRANSISTOR Q4 BASE	ANALOG ANALOG ANALOG ANALOG ANALOG ANALOG	
Q4C	TRANSISTOR Q4 COLLECTOR	ANALOG	
Q4E	TRANSISTOR Q4 EMITTER	ANALOG	
REN RFSWP	IEEE 488 REMOTE ENABLE (REN) SWEEP RAMP TO RF OUTPUT SECTION	DIGITAL ANALOG	TTL (LOW TRUE) 10V/SWEEP
RGND	REFERENCE GROUND	GROUND	0V
RPNSWP RPNSWP RTN	REAR PANEL SWEEP OUTPUT REAR PANEL SWEEP GROUND RETURN	ANALOG GROUND	10V/SWEEP 0V
RSTAT	READ STATUS I/D STROBE (15, R3.)	DIGITAL	TTL (LOW TRUE)
SIOA SIOB SPARE 1 SPARE 2 SR FBK SR PWR	I/O STROBE (FIRST HALF ADDRESSES) I/O STROBE (SECOND HALF ADDRESSES) DB0 OUTPUT MISCELLANEOUS CONTROL DB1 OUTPUT MISCELLANEOUS CONTROL YO SENSE RESISTOR FEEDBACK YO SENSE RESISTOR POWER	DIGITAL DIGITAL DIGITAL DIGITAL ANALOG ANALOG	TTL (LOW TRUE) TTL (LOW TRUE) TTL TTL -5 TO -17V -5V TO -17V

Table A62-1. Motherboard Wiring List

Mnemonic	Source	Destination
Q2B Q2E Q3B Q3C Q3E Q4B	XA53-21 XA53-1,19 XA52-7 XA52-6,30 XA52-8,32 XA52-3,27	Q2 BASE Q2 EMITTER Q3 BASE Q3 COLLECTOR Q3 EMITTER Q4 BASE
Q4C	XA52-1,2,25,26	Q4 COLLECTOR
Q4E	XA52-4,5,28,29	Q4 EMITTER
REN RFSWP	A62J7-10 XA57-42	XA60-2 XA27-17
RGND	A62 STAR GROUND POINT	XA23P1-6, 24, XA24-36, XA25-12, 34, XA26-11, 34, XA27-18, 28, 49, 60, XA28-21, 43, XA43-20, XA54-7, 25, XA55-10, 11, 25, 26, XA57-45, 46, 101 XA58-42, 43, 98, A62J4 SMC SHIELD, A62J5 SMC SHIELD, A62J6 SMC SHIELD, A62J11 SMC SHIELD A62J18 SMC SHIELD, A62J27 SMC SHIELD, A62J29-1 AND LUG NEXT TO A62J29, A62J32-1, GROUND TRACE NEXT TO 20/30 SWP, GROUND TRACE NEAR VSWP, GUARD TRACE AROUND PRETUNE, GUARD TRACE NEAR YO TUNE, GUARD TRACE AROUND PRETUNE, GUARD TRACE AROUND SYTMRES
RPNLSWP RPNLSWP RTN	XA57-44 XA57-100	A62J8 CENTER GUARD TRACE AROUND RPNL SWP, A62J8 SMC SHIELD
RSTAT	XA27-45	XA23-32, XA24-23, XA28-10
SIOA SIOB SPARE 1 SPARE 2 SR FBK SR PWR	XA60-15 XA60-16 A62J35-8 A62J35-6 XA55-12,27 XA55-13,28	XA27-42, XA57-15, XA58-15, XA59-15, A62J1-49 XA57-16, XA58-16, XA59-16, A62J1-47 XA59-71 XA59-70 A62J29-2 A62J29-3

A62 Motherboard Component Level Troubleshooting

Table A62-1. Motherboard Wiring List

Mnemonic	Description	Type	Levels
SRD BIAS SRD BIAS CONT SRQ STAT10	STEP RECOVERY DIODE BIAS STEP RECOVERY DIODE BIAS CONTROL IEEE 488 SERVICE REQUEST (SRQ) STATUS WORD INPUT BIT 10	ANALOG DIGITAL DIGITAL DIGITAL	-10V/2K TO +5V 0 TO -5 LEVELED TTL TTL (LOW TRUE)
SW1 SW2	PLL1 15-30 MHZ ON/OFF CONTROL PLL1 .15 TO .3 MHZ/3-6 MHZ CONTROL	DIGITAL DIGITAL	TTL TTL
SYTM COIL + SYTM COIL - SYTM GND SYTMDB SYTMDC SYTMHTR SYTMRES SYTM TEMP SYTMTHRM	POSITIVE INPUT TO SYTM COIL NEGATIVE INPUT TO SYTEM COIL SYTM GROUND SYTM DRIVE TRANSISTSOR BASE SYTM DRIVE TRANSISTOR COLLECTOR REGULATOR HEATER DRIVE TO SYTM SYTM CURRENT SENSE FEED BACK SYTM TEMPERATURE COIL TEMP FEED BACK THERMISTOR IN SYTM	ANALOG ANALOG GROUND ANALOG ANALOG ANALOG ANALOG ANALOG ANALOG	-40V TO -25V -40V 0V -22 TO -39 -.6 TO -6V 0 TO +20V -9V LOW BND CW 100 mv/c° APPROX -5V
TCREF THERM1 THERM2 TYOKP	ALC TEMP COMPENSATED REFERENCE LOW BAND DETECTOR THERMISTOR LOW BAND DETECTOR THERMISTOR TRIGGER YO KICK PULSE	ANALOG ANALOG ANALOG DIGITAL	-.2V/dB 0V=0dBm -1V TO -8V -10V TTL (LOW TRUE)
VCOMP VSWP	YO DELAY COMPENSATION VOLTAGE YO SWEEP RAMP	ANALOG ANALOG	-26 MHZ/VOLT 0V TO 10V/SWEEP
WBAND WCDAC WLEVEL WMOD WPDAC WRDAC	BAND INFO I/O STROBE (10, R2:) DELAY COMPENSATION DAC DATA STROBE (5, R3.) ALC REFERENCE DAC DATA STROBE (10, R1:) MODULATION DATA STROBE (10, R0.) PRE-TUNE DAC DATA STROBE (3, R2:) RESET DAC DATA STROBE (1, R2.)	DIGITAL DIGITAL DIGITAL DIGITAL DIGITAL DIGITAL	TTL (LOW TRUE) TTL (LOW TRUE) TTL (LOW TRUE) TTL (LOW TRUE) TTL (LOW TRUE) TTL (LOW TRUE)

A62 Motherboard Component Level Troubleshooting

Table A62-1. Motherboard Wiring List

Mnemonic	Source	Destination
SRD BIAS SRD BIAS CONT SRQ STAT10	XA24-25 XA26-18 A62J7-19 XA23-22	A62J18-2 XA24-13 XA60-9 XA24-4
SW1 SW2	XA42-32 XA42-14	XA36-23, XA40-24 XA40-22
SYTM COIL + SYTM COIL - SYTM GND SYTMDB SYTMDC SYTMHTR SYTMRES SYTM TEMP SYTMTHRM	XA28-42 A62J18-12 A62J18-13,14,15 XA28-19 XA28-20 XA24-19 XA28-44 A62J18-5 A62J18-9	A62J18-4, A62J32-3 XA28-5,27 XA24-35 A62J32-2 A62J32-4 A62J18-8 A62J32-5 XA27-13 XA24-2
TCREF THERM1 THERM2 TYOKP	XA25-35 A62J34-3 A62J34-1 XA59-100	XA26-12 XA25-4 XA25-26 XA54-18, XA58-30
VCOMP VSWP	XA54-27 XA58-97	XA55-9 A62J27 SMC CENTER THRU COAX TO A62J4 SMC CENTER, XA54-26
WBAND WCDAC WLEVEL WMOD WPDAC WRDAC	XA27-43 XA59-30 XA27-12 XA27-59 XA59-68 XA59-29	XA28-29 XA54-28 XA24-33 XA21-33, XA23-33, XA26-44 XA54-36 XA58-29

A62 Motherboard Component Level Troubleshooting

Table A62-1. Motherboard Wiring List

Mnemonic	Description	Type	Levels
WSPAT WSPTM WYOKW WYTMCTL WYTMSLP W11R2	SWEEP ATTENUATOR DATA STROBE (1, R0) SWEEP TIME DAC DATA STROBE (1, R1) YO KICK PULSE WIDTH DATA STROBE (5, R1) YTM CONTROL SIGNALS STROBE (11, R1) YTM DRIVE SLOPE DAC DATA STROBE (11, R1) EXTRA I/O STROBE (11, R2)	DIGITAL DIGITAL DIGITAL DIGITAL DIGITAL DIGITAL	TTL (LOW TRUE) TTL (LOW TRUE) TTL (LOW TRUE) TTL (LOW TRUE) TTL (LOW TRUE) TTL (LOW TRUE)
YO COIL + YO COIL - YO TUNE YOXISTB	POSITIVE INPUT TO YO COIL NEGATIVE INPUT TO YO COIL LOW FREQ PHASE LOCK TO YO DRIVER YO DRIVE TRANSISTOR BASE	ANALOG POWER SUPPLY ANALOG ANALOG	-40V TO -20V -40V 0V TO ±6V -30V TO -39V
Z-AXIS BLANK	2-AXIS BLANKING/MARKER	DIGITAL	+5V/-5V
1.4V/GHZ 20/30 SWP 500 KHZ REF 8410 TRIG	1.4V PER GHZ REFERENCE 20/30 MHZ REFERENCE OSCILLATOR SWEEP PLL2 500 KHZ REFERENCE SYNCHRONIZING TRIGGER TO 8410B INTERFACE	ANALOG ANALOG DIGITAL DIGITAL	+1.4V/GHZ 0V TO +10V TTL TTL
+1.0 V/GHZ +1.0 V/GHZ RTN +5V AC1	+1.0V/GHZ FREQUENCY REFERENCE +1.0V/GHZ FREQUENCY REFERENCE GROUND RETURN +5V TRANSFORMER SECONDARY	ANALOG GROUND TI SEC.	1.0V/GHZ 0V 7 VAC
+5V AC2	+5V TRANSFORMER SECONDARY (GREEN)	TI SEC.	7 VAC
+5V SENSE (+) +5V SENSE (-) +5V UNREG	+5.2 VOLT SUPPLY POSITIVE SENSE +5.2 VOLT SUPPLY POSITIVE SENSE UNREGULATED SUPPLY TO +5V	POWER SUPPLY POWER SUPPLY POWER SUPPLY	+5.2V 0V +7V TO +9V
+5.2V	REGULATED +5.2 VOLT SUPPLY	POWER SUPPLY	+5.2V

A62 Motherboard Component Level Troubleshooting

Table A62-1. Motherboard Wiring List

Mnemonic	Source	Destination
WSPAT WSPTM WYOKW WYTMCTL WYTMSLP W11R2	XA59-84 XA59-28 XA59-99 XA27-14 XA27-44 XA27-15	XA58-84 XA58-28 XA54-6 XA28-8 XA28-30 XA23-15
YO COIL + YO COIL - YO TUNE YOXISTB	XA55-15,30 A62J2-8,13 XA55-24 XA55-29	A62J2-6,15, A62J29-5 SEPARATE TRACE TO -40V SENSE POINT A62J6 SMC CENTER A62J29-4
Z-AXIS BLANK	XA57-97	A62J31-2,20
1.4V/GHZ 20/30 SWP 500 KHZ REF 8410 TRIG	XA28-7 XA58-41 XA42-9 XA57-62	XA24-6 XA43-1 XA41-20 A62J31-7
+1.0 V/GHZ +1.0 V/GHZ RTN +5V AC1	XA28-17 XA28-39 A62 LUG 5	A62J31-31,32 A62J31-13 XA35-8,9,10,26,27,28, T1 GREEN WIRE
+5V AC2	A62 LUG 5	XA35-12,13,14,30,31,32, T1 GREEN WIRE, A62CR1 ANODE
+5V SENSE(+) +5V SENSE(-) +5V UNREG	XA52-15 XA52-39 XA35-1, 2, 3, 19, 20, 21	TO TRACE ON A62 NEAR XA52-17, +5.2 VOLT SENSE POINT TO A62 STAR GROUND ^c XA52-13,14,37,38, A62C2(+), A62C3(+), THRU A62R3 TO GND
+5 2V	XA52-17,18,41,42	XA21-5,23, XA22-2,20 ^g , XA23-3,21, XA24-3, XA25-6,28, XA26-4,26, XA27-3,34, XA28-2,24, XA34P2-4,5, THRU A62L1 TO XA36-15,30, THRU A62L3 TO XA37-18,36, THRU A62L7 TO XA39-15,30, XA40-15,30, XA41-15,30, XA42-18,36, XA43-18,36, XA54-2,20, XA55-2,17, XA57-36,37,92, XA58-36,37,92, XA59-36,37,92, XA60-36,37,92, XA61-36,37,92 ⁱ , A62J1- 31 THRU 37, A62J2-4,17, A62J19-3,11, A62J31-3

^c M/N assembly ground plane connected to Star Ground through W45.

^g Reserved for future expansion.

ⁱ The A61 board assembly is not included with the HP 8340B. Traces connected to XA61 are included in this wiring list to keep signal destinations complete.

A62 Motherboard Component Level Troubleshooting

Table A62-1. Motherboard Wiring List

Mnemonic	Description	Type	Levels
+12V	REGULATED +12 VOLT SUPPLY	POWER SUPPLY	+12V
+12V UNREG +12V U1 ADJ	UNREGULATED SUPPLY TO +12V +12V REGULATOR ADJUSTMENT TERMINAL	POWER SUPPLY POWER SUPPLY	+20V +10.5V
+20V	REGULATED +20 VOLT SUPPLY	POWER SUPPLY	+20V
+20V AC1 +20V AC2 +20V REF OSC +20V UNREG	TRANSFORMER SECONDARY FOR +20V SUPPLY TRANSFORMER SECONDARY FOR +20V SUPPLY SWITCHED +20V SUPPLY TO 10 MHZ REF UNREGULATED SUPPLY TO +20V	POWER SUPPLY POWER SUPPLY POWER SUPPLY POWER SUPPLY	26.4 VAC 26.4 VAC 0V/+20V +31.2V
+22V -.25V/GHZ -5.2V -7V REF -10V	REGULATED +22 VOLT SUPPLY -.25 VOLTS/GHZ OUTPUT FREQUENCY REGULATED -5.2 VOLT SUPPLY -7V REFERENCE SUPPLY REGULATED -10 VOLT SUPPLY	POWER SUPPLY POWER SUPPLY POWER SUPPLY POWER SUPPLY POWER SUPPLY	+22V -.25V/GHZ -5.2V -7V -10V
-10V AC1	TRANSFORMER SECONDARY FOR -10V SUPPLY	POWER SUPPLY	13.9 VAC
-10V AC2	TRANSFORMER SECONDARY FOR -10V SUPPLY	POWER SUPPLY	13.9 VAC
-10V RTN	-10V SUPPLY SERIES PASS COLLECTOR	POWER SUPPLY	+6.4V AT 13.3 GHZ
-10V UNREG	UNREGULATED SUPPLY TO +10V	POWER SUPPLY	-10V

A62 Motherboard Component Level Troubleshooting

Table A62-1. Motherboard Wiring List

Mnemonic	Source	Destination
+12V +12V UNREG +12V U1 ADJ	XA52-9,33 XA52-11,35 XA52-10	XA23-2,20, XA57-91, XA58-91, XA59-91, XA60-91, XA61-91 ¹ , A62J1-2, A62CR3 CATHODE, A62U1 CASE A62U1-1, A62C7(+) A62C6(+), A62CR3 ANODE, THRU A62R4 TO GND, A62U1-2
+20V	XA52-16,40	XA21-4,22, XA22-1,19 ⁹ , XA23-1,19, XA24-1, XA25-5,27, XA26-3, XA27-2,33, XA28-1,23, XA34P2-2,3, THRU A62L2 TO XA36-13,28, THRU A62L5 TO XA38-13,28, XA40-13,28, XA41-13,28, XA42-16,34, XA43-16,34, XA52-16,40 (+20V SENSE POINT), XA53-29, XA54-1, XA55-1,16, XA57-35,90, XA58-35,90, XA59-35,90, XA60-35,90, XA61-35 ¹ , A62J2-9,12, A62J18-6, A62J19-2,10
+20V AC1 +20V AC2 +20V REF OSC +20V UNREG	A62 LUG 2 A62 LUG 2 XA52-20 XA35-7,25	XA19-1,13, T1 RED WIRE XA19-2,14, T1 RED WIRE A62J3-1 XA19-9,21, XA52-23,24,47,48
+22V - .25 V/GHZ -5.2V -7V REF -10V	XA35-18,36 XA28-40 XA53-18,36 XA43-9 XA53-12,13,31,32	XA60-88, XA61-90 ¹ , A62CR2 CATHODE, A62J1-30, A62J3-5, A62K1-2 XA25-38, XA27-51 XA23-4, XA27-1,32, XA34P2-12,13, XA52-22, XA57-93, XA58-93, XA59-93, XA60-93, XA61-93 ¹ , A62J1-42, A62J2-1,20, A62J19-4,12 XA41-7 XA21-7,25, XA22-4,22 ⁹ , XA23-5,23, XA24-5, XA25-7,29, XA26-5,27, XA27-4,35, XA28-3,25, XA34P2-8,9, THRU A62L8 TO XA36-12,27, THRU A62L4 TO XA38-12,27, THRU A62L6 TO XA39-12,27, XA40-12,27, XA41-12,27, XA42-15,33, XA43-15,33, XA54-4,22, XA55-4,19, XA56-4,19, XA57-39,94, XA58-39,94, XA59-39,94, XA60-39,94, XA61-39,94 ¹ , A62J2-10,11, A62J18-7, A62J19-5,13
-10V AC1	A62 LUG 6	XA19-3,4,15,16, T1 BLUE WIRE
-10V AC2	A62 LUG 6	XA19-5,6,17,18, T1 BLUE WIRE
-10V RTN	XA53-2,20	XA19-7,8,19,20, A62Q1 COLLECTOR
-10V UNREG	XA19-11,12,23,24	XA53-9,10,27,28

⁹ Reserved for future expansion.

¹ The A61 board assembly is not included with the HP 8340B. Traces connected to XA61 are included in this wiring list to keep signal destinations complete.

A62 Motherboard Component Level Troubleshooting

Table A62-1. Motherboard Wiring List

Mnemonic	Description	Type	Levels
-15V -40V	REGULATED -15V SUPPLY REGULATED -40V SUPPLY	POWER SUPPLY POWER SUPPLY	-15V -40V
-40V AC1 -40V AC2	TRANSFORMER SECONDARY FOR -40V SUPPLY TRANSFORMER SECONDARY FOR -40V SUPPLY	POWER SUPPLY	42.8 VAC 42.8 VAC
-40V RTN -40V SENSE (+) -40V SENSE (-) -40V UNREG	-40V SUPPLY SERIES PASS COLLECTOR -40V SUPPLY POSITIVE SENSE -40V SUPPLY NEGATIVE SENSE UNREGULATED SUPPLY TO -40V	POWER SUPPLY POWER SUPPLY POWER SUPPLY POWER SUPPLY	12.7V AT 13.3 GHZ 0V -40V -40V

Table A62-1. Motherboard Wiring List

Mnemonic	Source	Destination
-15V -40V	XA56-15,30 XA53-11,30	XA27-5,36, XA28-4, XA54-8, XA57-38, XA58-38, XA59-38, XA60-38, XA61-38 ⁱ XA22-3,21 ^g , XA23-7,25, XA28-5,27, XA34P2-6.7, XA40-11,26, XA53-11,30, XA54-3, XA55-3,18, XA56-3,18, A62J2-8,13, A62J19-6, A62C5
-40V AC1 -40V AC2	A62 LUG 4 A62 LUG 4	XA35-15,33, T1 YELLOW WIRE XA35-16,34, T1 YELLOW WIRE
-40V RTN -40V SENSE(+) -40V SENSE(-) -40V UNREG	XA53-3,22 XA53-5 XA53-23 XA35-6,24	XA35-5,23, A62C1(+), A62R2, A62Q2 COLLECTOR A62 STAR GROUND A62 -40V SENSE POINT XA53-6,24, A62C1(-), A62R2

^g Reserved for future expansion

ⁱ The A61 board assembly is not included with the HP 8340B. Traces connected to XA61 are included in this wiring list to keep signal destinations complete.

A62 Motherboard Component Level Troubleshooting

Table A62-2. HP 8340B Motherboard Coaxial Cables

Cable	Mnemonic/ Description	Type	Signal Level	Source	Destination
A62J12 CENTER A62J12 SHIELD	NOT USED NOT USED				XA23-36 XA23-35
A62J17 CENTER A62J17 SHIELD	FM INPUT A62 STAR GND	ANALOG GROUND	$\pm 8V$ 0V	J22 J22	XA23-18 XA23-17
A62J21 CENTER A62J21 SHIELD	NOT USED NOT USED				XA22-11 XA22-29
A62J22 CENTER A62J22 SHIELD	NOT USED NOT USED				XA22-10 XA22-28
A62J23 CENTER A62J23 SHIELD	NOT USED NOT USED				XA22-9 XA22-27
A62J24 CENTER A62J24 SHIELD	FM OUT FM OUT SHIELD	ANALOG GROUND	CURRENT SOURCE 0V	XA23-16 XA23-34	A44J3 A44J3

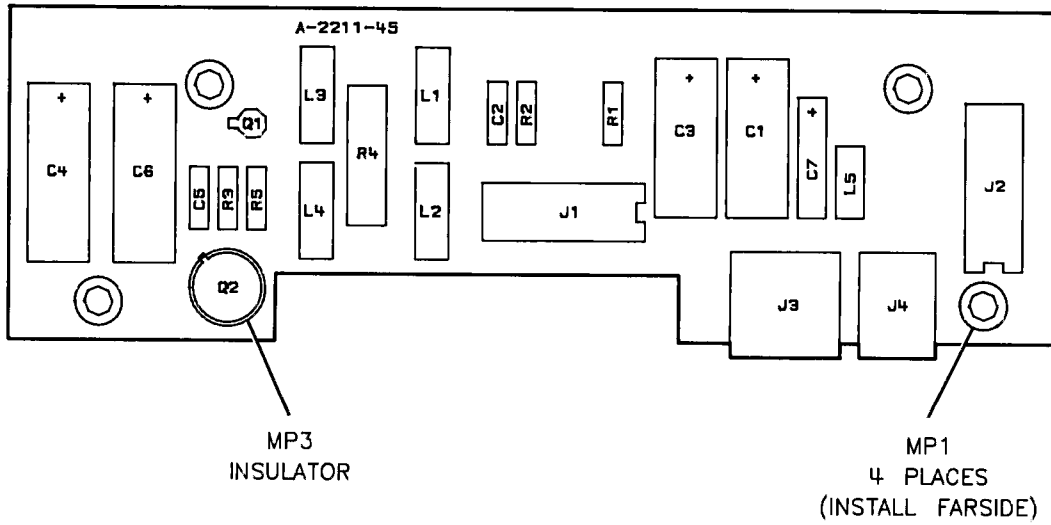

HP Part Number: 08340-60203

Figure A20-1. A20 RF Section Filter Component Location Diagram

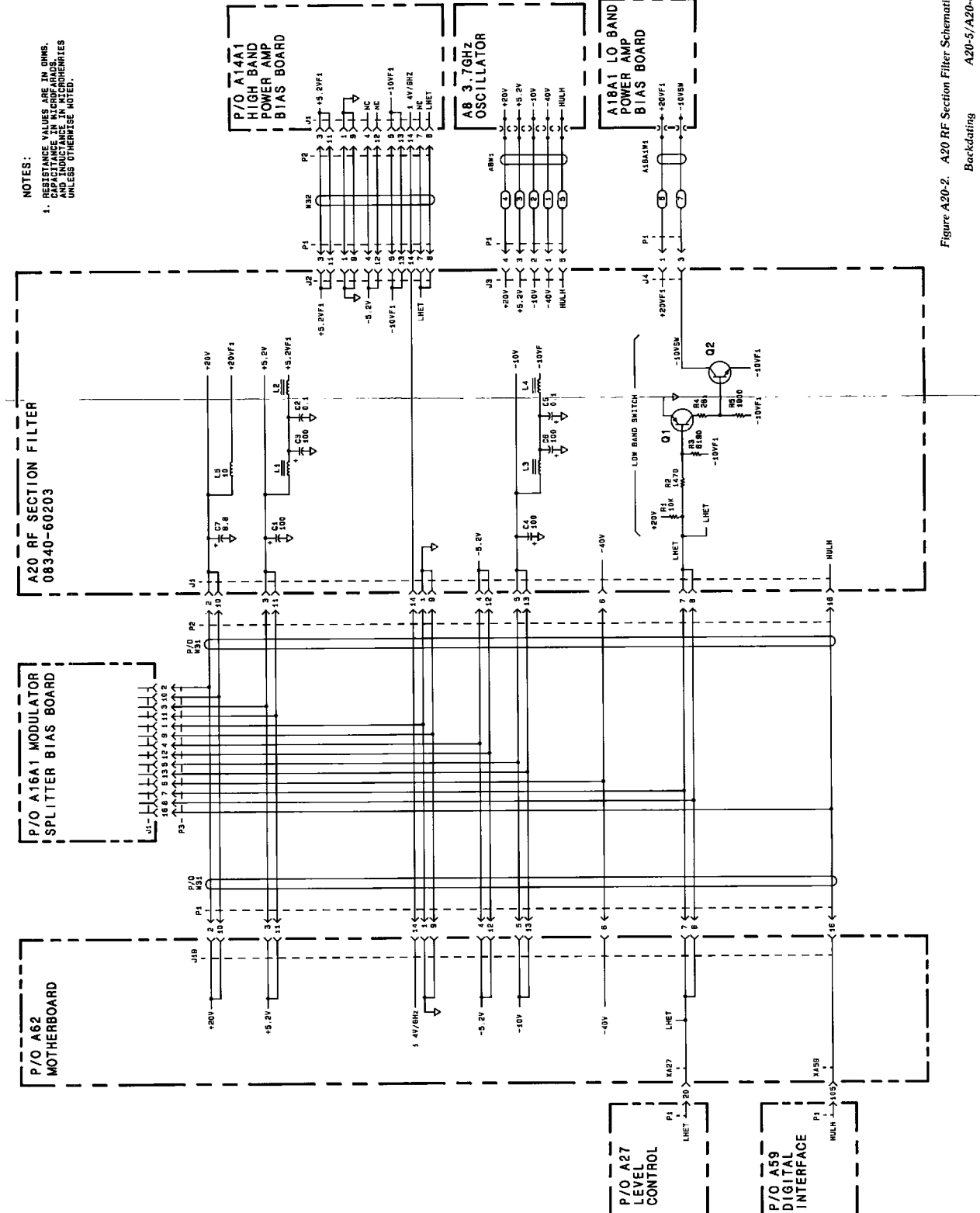

NOTES:

- RESISTANCE VALUES ARE IN OHMS, CAPACITANCE IN MICROFARADS, AND INDUCTANCE IN MICROHENRIES UNLESS OTHERWISE NOTED.

Figure A20-2. A20 RF Section Filter Schematic
Backdating A20-5/A20-6

A20 RF Section Filter Component-Level Troubleshooting

Table A20-2. A20 RF Section Filter Replaceable Parts

Reference Designation	HP Part Number	C D	Qty	Description	Mfr Code	Mfr Part Number
A20	08340-60203	4	1	RF SECTION FILTER ASSEMBLY	28480	08340-60203
A20C1	0180-2614	8	2	CAPACITOR-FXD 100UF ± 10% 30VDC TA	56289	150D107X9030S2
A20C2	0160-4835	7	2	CAPACITOR-FXD 1UF ± 10% 50VDC CER	28480	0160-4835
A20C3	0180-2614	8		CAPACITOR-FXD 100UF ± 10% 30VDC TA	56289	150D107X9030S2
A20C4	0180-0094	4	2	CAPACITOR-FXD 100UF + 75-10% 25VDC AL	56289	30D107G025DD2
A20C5	0160-4835	7		CAPACITOR-FXD 1UF ± 10% 50VDC CER	28480	0160-4835
A20C6	0180-0094	4		CAPACITOR-FXD 100UF + 75-10% 25VDC AL	56289	30D107G025DD2
A20C7	0180-0116	1	1	CAPACITOR-FXD 6 8UF ± 10% 35VDC TA	56289	150D685Y9035B2
A20J1	1200-0482	9	2	SOCKET-IC 16-CONT DIP-SLDR	28480	1200-0482
A20J2	1200-0482	9		SOCKET-IC 16-CONT DIP-SLDR	28480	1200-0482
A20J3	1251-6794	5	1	CONNECTOR HEADER 5 M IR	28480	1251-6794
A20J4	1251-6795	6	1	CONNECTOR HEADER 3 M IR	28480	1251-6795
A20L1	08340-80001	2	4	COIL-TOROID	28480	08340-80001
A20L2	08340-80001	2		COIL-TOROID	28480	08340-80001
A20L3	08340-80001	2		COIL-TOROID	28480	08340-80001
A20L4	08340-80001	2		COIL-TOROID	28480	08340-80001
A20L5	9100-0539	3	1	INDUCTOR (MISC ITEM)	28480	9100-0539
A20MP1	0380-0773	0	4	SPACER-RVT-ON 5-IN-LG 152-IN-ID	00000	ORDER BY DESCRIPTION
A20Q1	1853-0281	9	1	TRANSISTOR PNP 2N2907A SI TO-18 PD=400MW	04713	2N2907A
A20Q2	1854-0361	8	1	TRANSISTOR NPN 2N4239 SI TO-5 PD=6W	04713	2N4239
A20R1	0757-0442	9	1	RESISTOR 10K 1% 125W F TC=0 ± 100	24546	C4-1/8-T0-1002-F
A20R2	0757-1094	9	1	RESISTOR 1 47K 1% 125W F TC=0 ± 100	24546	C4-1/8-T0-1471-F
A20R3	0757-0290	5	1	RESISTOR 6 19K 1% 125W F TC=0 ± 100	19701	MF4C1/8-T0-6191-F
A20R4	0757-1090	5	1	RESISTOR 261 1% 5W F TC=0 ± 100	28480	0757-1090
A20R5	0757-0280	3	1	RESISTOR 1K 1% 125W F TC=0 ± 100	24546	C4-1/8-T0-1001-F

A21 Pulse Modulator Circuit Description

ASSEMBLY PURPOSE

The A21 pulse modulator assembly controls the synthesizer pulse modulation functions. The main control signal is the front panel BNC, PULSE MODULATION INPUT. The pulse modulator drives the PIN switch RF modulators in the A9 (low band) or A16 (high band) microcircuits.

Timing circuits send control signals to key elements of the ALC loop to coordinate the leveling function with the pulse modulation.

INPUT BUFFER AND CONTROL LOGIC (BLOCK A)

PULSE MODULATION (TTL compatible) is buffered as it enters this block. Two control lines gate the pulse input:

- HPLSEN (high pulse enable) gates the buffered pulses.
- HRFON (high RF on) overrides the pulse input, turning the RF off.

An eight-bit latch provides control lines and decoding signals for the rise time pulse driver and modulator driver circuitry. Control lines are also provided for the A25 ALC detector assembly.

Input Impedance

Input resistor R5 establishes the input impedance. If necessary, change the resistor value to 51 1Ω to provide a 50 Ω impedance. If you do this, however, be aware that an open-circuit input is no longer pulled high. This means that if pulse modulation is activated with an open-circuit input, the RF turns off.

SLOW RISE TIME PULSE DRIVER (BLOCK B)

Fast rise time pulse modulation produces a broad spectrum of harmonics that can result in measurement errors. To minimize harmonics, a pulse modulation mode is available that provides pulses of approximately 2 μ s rise and fall times.

When you activate the slow pulse mode (**[SHIFT] [PULSE]**), the input pulse is routed through block B to driver circuitry in the modulator driver (all pulses are routed to block C, but only slow pulse signals are routed through block B). The slow rise time driver amplifier, controls the driver circuitry. Wave shaping of the control signal provides a slow transition through the modulator turn-on region. To assure that the RF output has reached the proper level, the sample/hold timing is delayed until the pulse has risen.

Low and high band symmetry adjustments independently adjust the output for symmetrical RF pulse outputs.

MODULATOR DRIVER (BLOCK C)

The modulator driver provides the current and voltage bias for the RF pulse modulators. A differential current switch controls the bias for two transistor drivers. When the input (LPLSON) is high (RF off), the PIN diode modulator is biased on, turning the RF off. When the input is low, the PIN diode modulator is back-biased, turning the RF on.

Transistor driver output capacitors provide AC coupling for the transition current spikes from the modulators back to the A21 assembly.

Two FETs form an output multiplexer for low or high band modulator selection. Digital input signals (BAND0 and HIBAND) determine the modulator selection. Input control line LHET (block A) controls these digital lines.

INTEGRATOR TIMING (BLOCK D)

Block D controls the timing used to gate the ALC loop integrator input (A26). This ensures that the integrator responds to RF power level error signals only when the detected RF level is on and stable.

When the input (LOL) goes low (RF on), the output of the NAND gate is forced high. The low-pass filter following the NAND gate delays the transition by 1 μ s. When the output goes high, the integrator is enabled. When the input goes high (RF off), the NAND gate output goes low to put the integrator circuits on hold.

When the input (LOL) goes low, it triggers timers that output low pulses to the output NAND gate. This determines the minimum time the output is high for each RF pulse. The pulse time period depends on the ALC loop bandwidth and is controlled by timing control signals from the control logic (block A). Internal leveling sample time is 1 or 10 μ s, depending on the bandwidth. External leveling sample time is 0.2 μ s.

ADC TIMING (BLOCK E)

The ADC timing lets the A27 assembly monitor the detected power level when either the RF is on, or up to 1.8 ms after the RF is turned off. This prevents the POWER dBm display from showing an invalid power level if the RF is turned off for over 1.8 ms (ALC sample/hold droop).

When the input is low (RF on), the output is forced high to enable the clock control circuitry on the A27 assembly. When the input goes high, the one-shot timer outputs a 1.8 ms low pulse, holding the clock control enabled. If the RF does not turn on again within 1.8 ms, the timer output goes high, forcing the output to disable the clock control.

SAMPLE/HOLD TIMING (BLOCK F)

Block F controls the timing of the sample/hold gate in detector circuits on the A25 assembly during pulse modulation. The key timing element is C19. The time delay constant is independent and adjustable for both RF on and RF off. The voltage on C19 is detected by a schmitt trigger whose square wave output is delayed by the pulse from the control logic section.

ON DELAY adjustments (for both system and internal leveling) adjust the discharge time, and OFF DELAY adjusts the charging time of C19.

If C19 is not fully discharged before the timing input goes high, the rising edge briefly turns on a discharge transistor circuit to fully discharge C19. This ensures that the OFF DELAY is independent of the pulse width.

A21 Pulse Modulator Component-Level Troubleshooting

Table A21-1. A21 Pulse Modulator Driver P1 Pin I/O

Pin	Mnemonic	Levels	Source	Destination
1 19	HADCEN	TTL (HIGH TRUE)	D	XA27P1-8
2 20	LMODHLD	TTL	E	XA26P1-1
3 21	DET S/H + DET S/H -	+4.5V/+3.5V +3.5V/+4.5V	F F	XA25P1-2 XA25P1-24
4 22	+20V	+20V	XA52P1-16, 40	*G
5 23	+5.2V	+5.2V	XA52P1-17, 18, 41, 42	*G
6 24	HLBW	TTL (HIGH TRUE)	XA26P1-33	XA26P1-33
7 25	-10v -10V	-10v -10V	XA53p1-12, 13, 31, 32 XA53P1-12, 13, 31, 32	*G *G
8 26	GND GND	0V 0V	A62 STAR GND A62 STAR GND	*G *G
9 27	HPLSEN HRFON	TTL (HIGH TRUE) TTL (HIGH TRUE)	XA26P1-2 XA57P1-105	*A *A C
10 28				
11 29	LHET	TTL (LOW TRUE)	XA27P1-20	*C
12 30				
13 31				
14 32				
15 33				
16 34	LOPMOD DRV	CURRENT SOURCE	C	A62J10-SMC CENTER
17 35	PLS IN RTN PMOD RTN	0V PV	* B	*A *A
18 36	PLS IN HIPMOD DRV	TTL CURRENT TO PIN DIODE	A62J26-SMC CENTER C	A A62J25-SMC CENTER

A single letter in the source or destination column refers to a function block on this assembly schematic.

An asterisk (*) denotes multiple sources or destinations, refer to the A62 motherboard wiring list for a complete representation of signal sources and destinations.

A21 Pulse Modulator Component-Level Troubleshooting

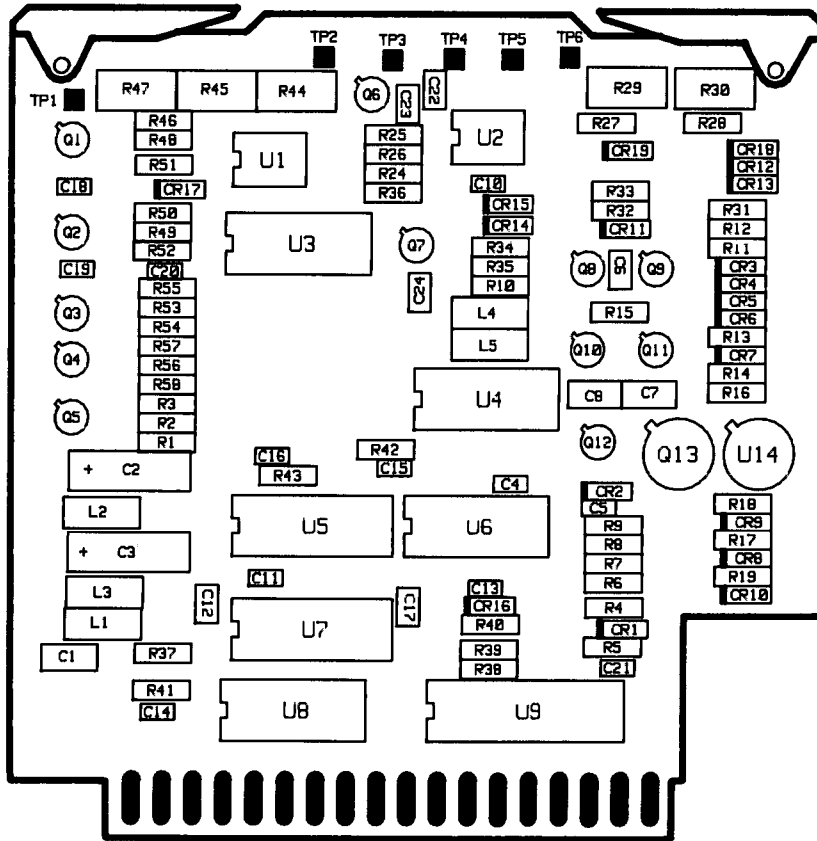

HP Part Number: 08340-60265

Figure A21-1. A21 Pulse Modulator Component Location Diagram

A21 PULSE MODULATOR DRIVER
08340-60265

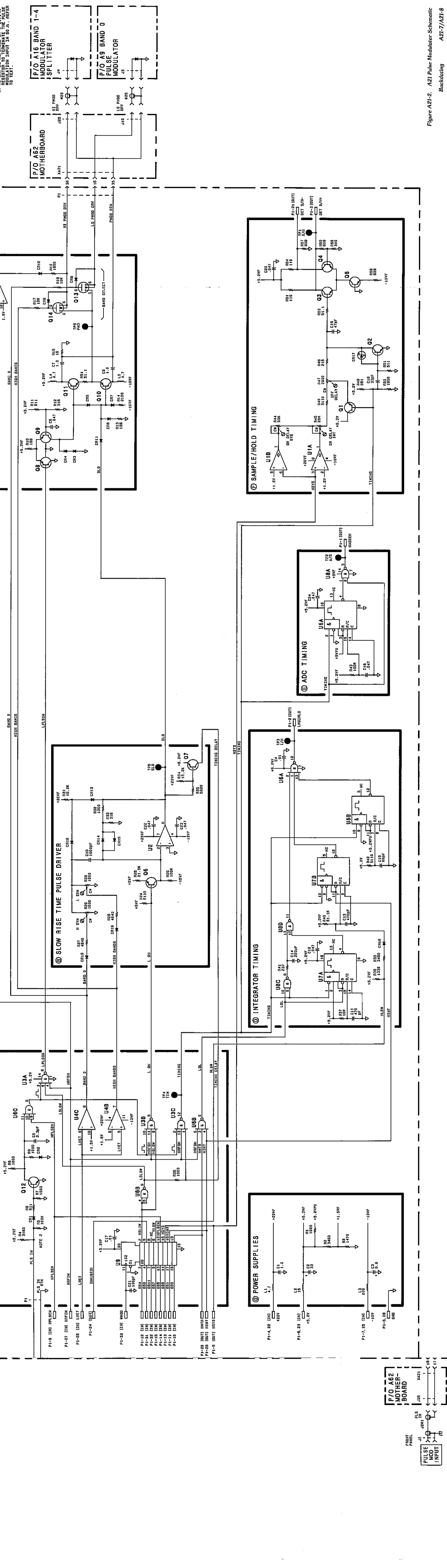

NOTES:
1. RESISTANCE VALUES ARE IN OHMS, UNLESS OTHERWISE INDICATED. CAPACITANCE VALUES ARE IN MICROFARADS, UNLESS OTHERWISE NOTED.
2. R5 CAN BE REPLACED BY A 51.1 Ω RESISTOR TO TERMINATE THE PULSE RESISTOR FOR INPUT IN 50 Ω. REFER TO TEXT.

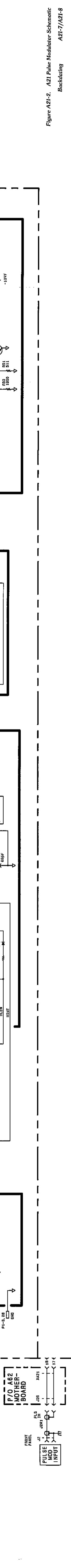

Figure A21-2. A21 Pulse Modulator Schematic Backdating A21-7/A21-8

A21 Pulse Modulator Component-Level Troubleshooting

Table A21-2. A21 Pulse Modulator Replaceable Parts

Reference Designation	HP Part Number	C D	Qty	Description	Mfr Code	Mfr Part Number
A21	08340-60265	8	1	PULSE MODULATOR DRIVER	28480	08340-60265
A21C1	0160-4535	4	3	CAPACITOR-FXD 1UF ±5% 50VDC CER	28480	0160-4535
A21C2	0180-0229	7	1	CAPACITOR-FXD 33UF ±20% 10VDC TA	28480	0180-0229
A21C3	0180-0116	1	1	CAPACITOR-FXD 6 8UF ±20% 35VDC TA	28480	0180-0116
A21C4	0160-0575	4	9	CAPACITOR-FXD 047UF ±20% 50VDC CER	28480	0160-0575
A21C5	0160-4797	0	1	CAPACITOR-FXD 3 3PF ±20% 100VDC CER	28480	0160-4797
A21C6	0160-0575	4		CAPACITOR-FXD 047UF ±20% 50VDC CER	28480	0160-0575
A21C7	0160-4535	4		CAPACITOR-FXD 1UF ±5% 50VDC CER	28480	0160-4535
A21C8	0160-4535	4		CAPACITOR-FXD 1UF ±5% 50VDC CER	28480	0160-4535
A21C9				NOT ASSIGNED		
A21C10	0160-4822	2	1	CAPACITOR-FXD 1000PF ±5% 100VDC CER	28480	0160-4822
A21C11	0160-4808	4	2	CAPACITOR-FXD 470PF ±5% 100VDC CER	28480	0160-4808
A21C12	0160-0575	4		CAPACITOR-FXD 047UF ±20% 50VDC CER	28480	0160-0575
A21C13	0160-4808	4		CAPACITOR-FXD 470PF ±5% 100VDC CER	28480	0160-4808
A21C14	0160-4812	0	1	CAPACITOR-FXD 220PF ±5% 100VDC CER	28480	0160-4812
A21C15	0160-4803	9	1	CAPACITOR-FXD 68PF ±5% 100VDC CER	28480	0160-4803
A21C16	0160-0575	4		CAPACITOR-FXD 047UF ±20% 50VDC CER	28480	0160-0575
A21C17	0160-0575	4		CAPACITOR-FXD 047UF ±20% 50VDC CER	28480	0160-0575
A21C18	0160-4807	3	1	CAPACITOR-FXD 33PF 5% 100V CER	28480	0160-4807
A21C19	0160-4805	1	1	CAPACITOR-FXD 47PF 5% 100V CER	28480	0160-4805
A21C20	0160-0575	4		CAPACITOR-FXD 047UF ±20% 50VDC CER	28480	0160-0575
A21C21	0160-4801	7	1	CAPACITOR-FXD 047UF 20% 50V CER	28480	0160-4801
A21C22	0160-0575	4		CAPACITOR-FXD 047UF ±20% 50VDC CER	28480	0160-0575
A21C23	0160-0575	4		CAPACITOR-FXD 047UF ±20% 50VDC CER	28480	0160-0575
A21C24	0160-0575	4		CAPACITOR-FXD 047UF ±20% 50VDC CER	28480	0160-0575
A21CR1	1901-0050	3	9	DIODE-SWITCHING 80V 200MA 2NS DO-35	28480	1901-0050
A21CR2	1901-0050	3		DIODE-SWITCHING 80V 200MA 2NS DO-35	28480	1901-0050
A21CR3	1901-0050	3		DIODE-SWITCHING 80V 200MA 2NS DO-35	28480	1901-0050
A21CR4	1901-0050	3		DIODE-SWITCHING 80V 200MA 2NS DO-35	28480	1901-0050
A21CR5	1901-0050	3		DIODE-SWITCHING 80V 200MA 2NS DO-35	28480	1901-0050
A21CR6	1901-0050	3		DIODE-SWITCHING 80V 200MA 2NS DO-35	28480	1901-0050
A21CR7	1901-0050	3		DIODE-SWITCHING 80V 200MA 2NS DO-35	28480	1901-0050
A21CR8	1901-0050	3		DIODE-SWITCHING 80V 200MA 2NS DO-35	28480	1901-0050
A21CR9	1901-0050	3		DIODE-SWITCHING 80V 200MA 2NS DO-35	28480	1901-0050
A21CR10	1901-0050	3		DIODE-SWITCHING 80V 200MA 2NS DO-35	28480	1901-0050
A21CR11	1901-0050	3		DIODE-SWITCHING 80V 200MA 2NS DO-35	28480	1901-0050
A21CR12	1901-0050	3		DIODE-SWITCHING 80V 200MA 2NS DO-35	28480	1901-0050
A21CR13	1901-0050	3		DIODE-SWITCHING 80V 200MA 2NS DO-35	28480	1901-0050
A21CR14	1901-0050	3		DIODE-SWITCHING 80V 200MA 2NS DO-35	28480	1901-0050
A21CR15	1901-0050	3		DIODE-SWITCHING 80V 200MA 2NS DO-35	28480	1901-0050
A21CR16	1901-0050	3		DIODE-SWITCHING 80V 200MA 2NS DO-35	28480	1901-0050
A21CR17	1901-0539	3	1	DIODE-SM SIG SCHOPTTK Y	28480	1901-0539
A21CR18	1901-0050	3		DIODE-SWITCHING 80V 200MA 2NS DO-35	28480	1901-0050
A21CR19	1901-0050	3		DIODE-SWITCHING 80V 200MA 2NS DO-35	28480	1901-0050
A21L1	9100-3562	8	3	COIL-4 7 UH 5%	28480	9100-3562
A21L2	9100-3912	2	1	INDUCTOR RF-CH-MLD 220UH 5% 166DX 385LG	28480	9140-0129
A21L3	9140-0129	1	1	INDUCTOR RF-CH-MLD 220UH 5% 166DX 385LG	28480	9140-0129
A21L4	9140-3562	8		COIL-4 7 UH 5%	28480	9100-3562
A21L5	9100-3562	8		COIL-4 7 UH 5%	28480	9100-3562
A21MP1	4040-0750	7	1	EXTR-PC BD RED POLYC 062-BD-THKNS	28480	4040-0750
A21MP2	4040-0749	4	1	EXTR-PC BD BRN POLYC 062-BD-THKNS	28480	4040-0749
A21MP3, 4	1480-0073	6	2	PIN-ROLL 062-IN-DIA 25-IN-LG BE-CU	28480	1480-0073
A21Q1	1854-0809	9	7	TRANSISTOR NPN 2N2369A SI TO-18 PD=360MW	28480	1854-0809
A21Q2	1854-0809	9		TRANSISTOR NPN 2N2369A SI TO-18 PD=360MW	28480	1854-0809
A21Q3	1854-0809	9		TRANSISTOR NPN 2N2369A SI TO-18 PD=360MW	28480	1854-0809
A21Q4	1854-0809	9		TRANSISTOR NPN 2N2369A SI TO-18 PD=360MW	28480	1854-0809
A21Q5	1854-0809	9		TRANSISTOR NPN 2N2369A SI TO-18 PD=360MW	28480	1854-0809
A21Q6	1853-0405	9	3	TRANSISTOR PNP 2N4209A SI TO-18 PD=360MW	28480	1854-0405
A21Q7	1853-0405	9		TRANSISTOR PNP 2N4209A SI TO-18 PD=360MW	28480	1854-0405
A21Q8	1853-0018	0	2	TRANSISTOR PNP SI 2N4260	28480	1853-0018
A21Q9	1853-0018	0		TRANSISTOR PNP SI 2N4260	28480	1853-0018
A21Q10	1853-0405	9		TRANSISTOR PNP 2N4209A SI TO-18 PD=360MW	28480	1854-0405
A21Q11	1854-0809	9		TRANSISTOR NPN 2N2369A SI TO-18 PD=360MW	28480	1854-0809
A21Q12	1854-0809	9		TRANSISTOR NPN 2N2369A SI TO-18 PD=360MW	28480	1854-0809
A21Q13	1855-0251	7	2	TRANSISTOR NPN 2N6659	28480	1855-0251
A21Q14	1855-0251	7		TRANSISTOR NPN 2N6659	28480	1855-0251
A21R1	0757-0280	3	6	RESISTOR 1K 1% 125W F TC=0±100	24546	C4-1/8-T0-1001-F
A21R2	0698-3152	8	2	RESISTOR 3 48K 1% 125W F TC=0±100	24546	C4-1/8-T0-3481-F
A21R3	0757-1094	9	1	RESISTOR 1 47K 1% 125W F TC=0±100	24546	C4-1/8-T0-1471-F
A21R4	0757-0279	0	1	RESISTOR 3 16K 1% 125W F TC=0±100	24546	C4-1/8-T0-3161-F
A21R5	0757-0465	6	3	RESISTOR 100K 1% 125W F TC=0±100	24546	C4-1/8-T0-1003-F

A21 Pulse Modulator Component-Level Troubleshooting

Table A21-2 A21 Pulse Modulator Replaceable Parts

Reference Designation	HP Part Number	C	D	Qty	Description	Mfr Code	Mfr Part Number
A21R6	0575-0416	7		3	RESISTOR 511 1% 125W F TC=0±100	24546	C4-1/8-T0-511R-F
A21R7	0757-0280	3		3	RESISTOR 1K 1% 125W F TC=0±100	24546	C4-1/8-T0-1001-F
A21R8	0757-0280	3		3	RESISTOR 1K 1% 125W F TC=0±100	24546	C4-1/8-T0-1001-F
A21R9	0757-0280	3		3	RESISTOR 1K 1% 125W F TC=0±100	24546	C4-1/8-T0-1001-F
A21R10	0698-3440	7		2	RESISTOR 196 1% 125W F TC=0±100	24546	C4-1/8-T0-196R-F
A21R11	0575-0416	7		7	RESISTOR 511 1% 125W F TC=0±100	24546	C4-1/8-T0-511R-F
A21R12	0698-3444	4		3	RESISTOR 316 1% 125W F TC=0±100	24546	C4-1/8-T0-316R-F
A21R13	0698-3440	7		7	RESISTOR 196 1% 125W F TC=0±100	24546	C4-1/8-T0-196R-F
A21R14	0698-0084	9		1	RESISTOR 2.15K 1% 125W F TC=0±100	24546	C4-1/8-T0-2151-F
A21R15	0757-0394	0		2	RESISTOR 51 1K 1% 125W F TC=0±100	24546	C4-1/8-T0-51R1-F
A21R16	0757-0346	2		1	RESISTOR 10 1% 125W F TC=0±100	24546	C4-1/8-T0-10R0-F
A21R17	0757-0442	9		3	RESISTOR 10K 1% 125W F TC=0±100	24546	C4-1/8-T0-1002-F
A21R18	0757-0442	9		9	RESISTOR 10K 1% 125W F TC=0±100	24546	C4-1/8-T0-1002-F
A21R19	0698-0083	8		2	RESISTOR 1.96K 1% 125W F TC=0±100	24546	C4-1/8-T0-1961-F
A21R20					NOT ASSIGNED		
A21R21					NOT ASSIGNED		
A21R22					NOT ASSIGNED		
A21R23					NOT ASSIGNED		
A21R24	0757-0438	3		3	RESISTOR 5.11K 1% 125W F TC=0±100	24546	C4-1/8-T0-5111-F
A21R25	0757-0199	3		1	RESISTOR 21.5K 1% 125W F TC=0±100	24546	C4-1/8-T0-2152-F
A21R26	0757-0465	6		6	RESISTOR 100K 1% 125W F TC=0±100	24546	C4-1/8-T0-1003-F
A21R27	0698-3155	5		2	RESISTOR 4.64K 1% 125W F TC=0±100	24546	C4-1/8-T0-4641-F
A21R28	0698-3155	5		5	RESISTOR 4.64K 1% 125W F TC=0±100	24546	C4-1/8-T0-4641-F
A21R29	2100-3352	7		2	RESISTOR-TRMR 1K 10% C SIDE-ADJ 1-TRN	28480	2100-3352
A21R30	2100-3352	7		7	RESISTOR-TRMR 1K 10% C SIDE-ADJ 1-TRN	28480	2100-3352
A21R31	0757-0447	4		2	RESISTOR 11.2K 1% 125W F TC=0±100	24546	C4-1/8-T0-1622-F
A21R32	0757-0280	3		3	RESISTOR 1K 1% 125W F TC=0±100	24546	C4-1/8-T0-1001-F
A21R33	0698-3444	4		4	RESISTOR 316 1% 125W F TC=0±100	24546	C4-1/8-T0-316R-F
A21R34	0757-0447	4		4	RESISTOR 11.2K 1% 125W F TC=0±100	24546	C4-1/8-T0-1622-F
A21R35	0757-0200	7		1	RESISTOR 5.62K 1% 125W F TC=0±100	14546	C4-1/8-T0-5621-F
A21R36	0757-0280	3		3	RESISTOR 1K 1% 125W F TC=0±100	24546	C4-1/8-T0-1001-F
A21R37	0757-0442	9		9	RESISTOR 10K 1% 125W F TC=0±100	24546	C4-1/8-T0-1002-F
A21R38	0757-0317	7		1	RESISTOR 1.33K 1% 125W F TC=0±100	24546	C4-1/8-T0-1331-F
A21R39	0698-3152	8		8	RESISTOR 3.48K 1% 125W F TC=0±100	24546	C4-1/8-T0-3481-F
A21R40	0757-0458	8		1	RESISTOR 51.1K 1% 125W F TC=0±100	24546	C4-1/8-T0-5112-F
A21R41	0698-3442	7		1	RESISTOR 237 1% 125W F TC=0±100	24546	C4-1/8-T0-237R-F
A21R42	0757-0438	3		3	RESISTOR 5.11K 1% 125W F TC=0±100	24546	C4-1/8-T0-5111-F
A21R43	0757-0465	6		6	RESISTOR 100K 1% 125W F TC=0±100	24546	C4-1/8-T0-1003-F
A21R44	2100-3354	9		1	RESISTOR-TRMR 50K 10% C SIDE-ADJ 1-TRN	28480	2100-3354
A21R45	2100-3353	8		1	RESISTOR-TRMR 20K 10% C SIDE-ADJ 1-TRN	28480	2100-3353
A21R46	0757-0438	3		3	RESISTOR 5.11K 1% 125W F TC=0±100	24546	C4-1/8-T0-5111-F
A21R47	2100-3273	1		1	RESISTOR-TRMR 2K 10% C SIDE-ADJ 1-TRN	28480	2100-3273
A21R48	0698-3441	8		1	RESISTOR 215 1% 125W F TC=0±100	24546	C4-1/8-T0-215R-F
A21R49	0757-0419	0		1	RESISTOR 681 1% 125W F TC=0±100	24546	C4-1/8-T0-681R-F
A21R50	0698-0083	8		8	RESISTOR 1.96K 1% 125W F TC=0±100	24546	C4-1/8-T0-1961-F
A21R51	0575-0416	7		7	RESISTOR 511 1% 125W F TC=0±100	24546	C4-1/8-T0-511R-F
A21R52	0757-0394	0		2	RESISTOR 51 1K 1% 125W F TC=0±100	24546	C4-1/8-T0-51R1-F
A21R53	0757-0402	1		2	RESISTOR 110 1% 125W F TC=0±100	24546	C4-1/8-T0-110R-F
A21R54	0757-0402	1		1	RESISTOR 110 1% 125W F TC=0±100	24546	C4-1/8-T0-110R-F
A21R55	0757-0418	9		1	RESISTOR 619 1% 125W F TC=0±100	24546	C4-1/8-T0-619R-F
A21R56	0698-3444	4		4	RESISTOR 316 1% 125W F TC=0±100	24546	C4-1/8-T0-316R-F
A21R57	0757-0422	5		2	RESISTOR 909 1% 125W F TC=0±100	24546	C4-1/8-T0-909R-F
A21R58	0757-0422	5		5	RESISTOR 909 1% 125W F TC=0±100	24546	C4-1/8-T0-909R-F
A21TP1	0360-0535	0		6	TERMINAL TEST POINT PCB	00000	ORDER BY DESCRIPTION
A21TP2	0360-0535	0		6	TERMINAL TEST POINT PCB	00000	ORDER BY DESCRIPTION
A21TP3	0360-0535	0		6	TERMINAL TEST POINT PCB	00000	ORDER BY DESCRIPTION
A21TP4	0360-0535	0		6	TERMINAL TEST POINT PCB	00000	ORDER BY DESCRIPTION
A21TP5	0360-0535	0		6	TERMINAL TEST POINT PCB	00000	ORDER BY DESCRIPTION
A21TP6	0360-0535	0		6	TERMINAL TEST POINT PCB	00000	ORDER BY DESCRIPTION
A21U1	1826-1229	0		1	IC V RGLTR-Fx0-POS 4 8/5 2V TO-202 PKG	27014	LM78M05CP
A21U2	1826-1049	2		1	IC OP AMP PRCN 8-DIP-C PKG	28480	1826-1049
A21U3	1820-2775	1		2	IC GATE TTL ALS NAND TPL 3-INP	01295	SN71546N
A21U4	1826-0161	7		1	IC OP AMP GP QUD 14-DIP-P PKG	04713	MLM324P
A21U5	1820-1423	4		2	IC MV TTL LS MONOSTBL RETRIG DUAL	01295	SN74LS123N
A21U6	1820-2775	1		2	IC GATE TTL ALS NAND TPL 3-INP	01295	SN71546N
A21U7	1820-1423	4		2	IC MV TTL LS MONOSTBL RETRIG DUAL	01295	SN74LS123N
A21U8	1820-2656	7		1	IC GATE TTL ALS NAND QUAD 2-INP	01295	SN71338N
A21U9	1820-1858	9		1	IC FF TTL LS D-TYPE OCTL	01295	SN58490N

BACKDATING G (serial number prefix 2804A)

Firmware changes reflected on the A60 processor assembly and revisions to the A58 sweep generator assembly.

Instructions

Replace the existing manual pages with the pages provided in this backdating subsection to reflect the instrument configuration.

Replace the following pages:

A58-9, A58-10, Volume 1, section D – Sweep Generator/YO Loop
A58-20 through A58-28, Volume 1, section D – Sweep Generator/YO Loop

A60-1 through A60-4, Volume 2, section F – Controller
A60-26 through A60-34, Volume 2, section F – Controller with pages numbered A60-30 through A60-38.

The actual sweep width is determined jointly by the sweep width DAC and the sweep width range attenuator (block N). The sweep width range attenuator (block N) selects the correct decade range, and the sweep width DAC interpolates within that selected range. The two sweep width DAC attenuation factors are multiplied by the instrument processor, and the result is applied to the digital input of the sweep width DAC.

CR5 protects U11, in case the +5 volt supply comes up before the +15 volt supply. CR7 protects CR5 in the event that the +15 volt supply is shorted to ground. CR6 protects the output of U11 by keeping it from going much below ground. C39 is a compensation capacitor.

SWEEP WIDTH RANGE ATTENUATOR (BLOCK N)

R58, R59, R61, and R62 form a decade voltage divider stack. The voltage at each node is a factor of 10 smaller than the voltage at the node above it. Q8, Q10, or Q12 is turned on to select the appropriate node. U17 is a unity gain buffer that drives the VSWP line.

In instrument sweeps of greater than 5 GHz, a gain of six is necessary in this block. To accomplish this, Q7 is turned on and the output of U16 is fed to the buffer.

Only one of the FET switches in this block is on at any given time. VSWP is fed back to U36 in sweep width range switch driver (block F) and becomes the supply voltage for the range switch pull-up resistors. When a FET is on, the voltage at its gate is equal to VSWP. When the FET is off, the gate voltage is approximately -15 volts.

In sweep widths where the YO is sweeping less than 5 MHz, the 20-30 Loop is swept and the YO loop stays phase-locked. This scheme gives better noise performance for narrow sweeps. However, for the first range of sweep widths where the YO sweep width is between 500 kHz and 5 MHz, the PRETUNE voltage is also swept. The SYTM also uses the PRETUNE voltage to improve the YO/SYTM tracking. In this case Q9 is turned on.

For sweeps narrower than 500 kHz, tracking is not a problem (the SYTM bandwidth is about 25 MHz), and only the 20-30 loop is swept.

NOTE: The sweep mode used, 20-30 loop sweep, or PRETUNE sweep, depends not on the actual instrument sweep width but the YO sweep width. For instance, if the instrument is set to sweep from 17 GHz to 20 GHz, the instrument sweep width is 3 GHz but the YO sweep width is 1 GHz, because the third harmonic of the YO is used.

For YO sweep widths less than 500 kHz, in MANUAL or CW modes, VSWP is turned off. To keep any noise from the sweep generator from getting to the pretune DAC and degrading the phase noise performance.

SWEEP BUFFER (BLOCK O)

U18 simply inverts VSWP. This output (BVSWP) is used on the A27 level control assembly ADC to measure VSWP when troubleshooting the sweep circuitry.

SWEEP CONTROL LOGIC (BLOCK P)

The sweep control logic takes HSP (high sweep), LRSP (low reset sweep), and LBX (low bandcross) and generates control signals to drive the front panel sweep LED (LSPLD low sweep LED), reset amplifier 1 (block R), the current shunt, and the reset control logic.

The sweep control logic timing diagram, Figure A58-4, shows what happens at the end of sweep and at bandcrossings. The arrows and numbers indicate the sequence of events as well as the cause and effect relationship of various transitions.

When marker ramp gets to +10 volts, indicating the end of a sweep, LBX (low bandcross, TP6) or HSP (high sweep) going low causes the LOW RESET line to go low. This in turn forces LHLD (low hold sweep, TP12) low, turning on the current shunt (block Q). Finally LSPLD (low sweep LED, U32A pin 3) goes high, turning off the front panel sweep LED.

At the appropriate time the instrument processor asserts LRSP (low reset sweep, TP11) which causes LRESET (low reset, TP13) to go low. This allows reset amplifier 1 (block R) to pull the output of U9 to ground. LRESET going low causes LHLD to go high, turning off the current shunt.

During the repeat-phase-lock sequence, the instrument processor releases LBX and LRSP. These events do not cause any changes on the sweep generator.

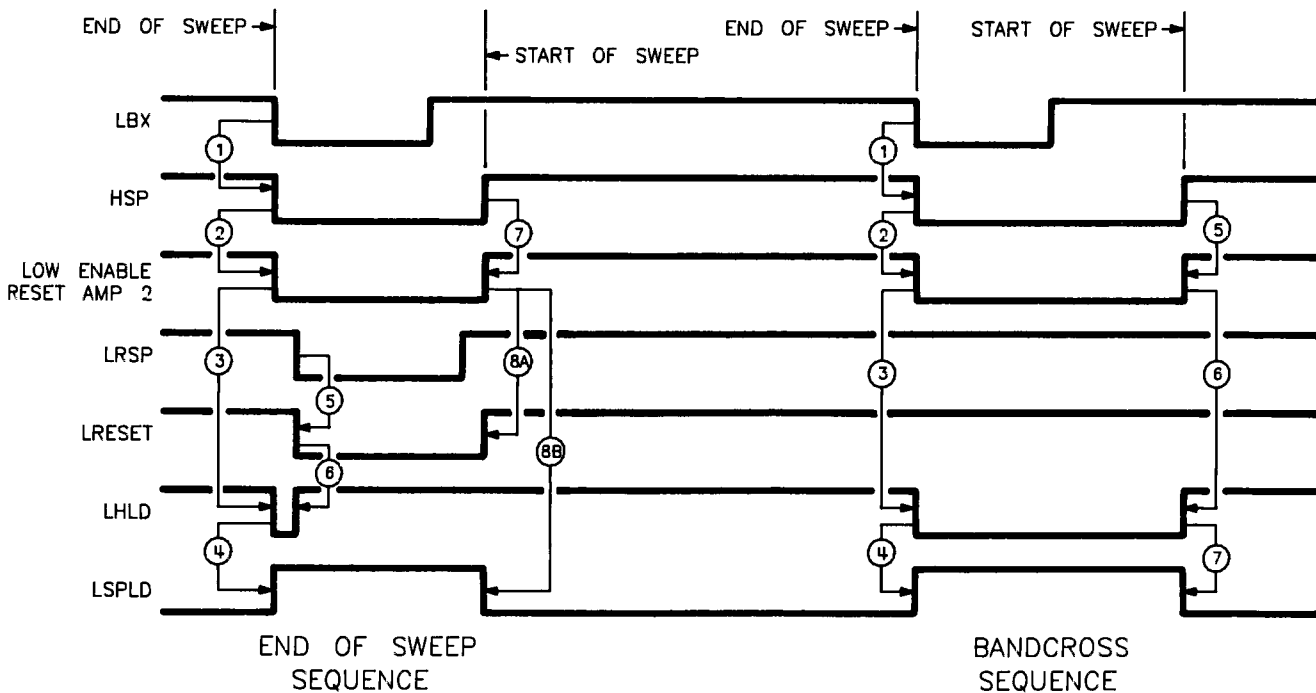

Figure A58-4. Sweep Control Logic Timing Diagram

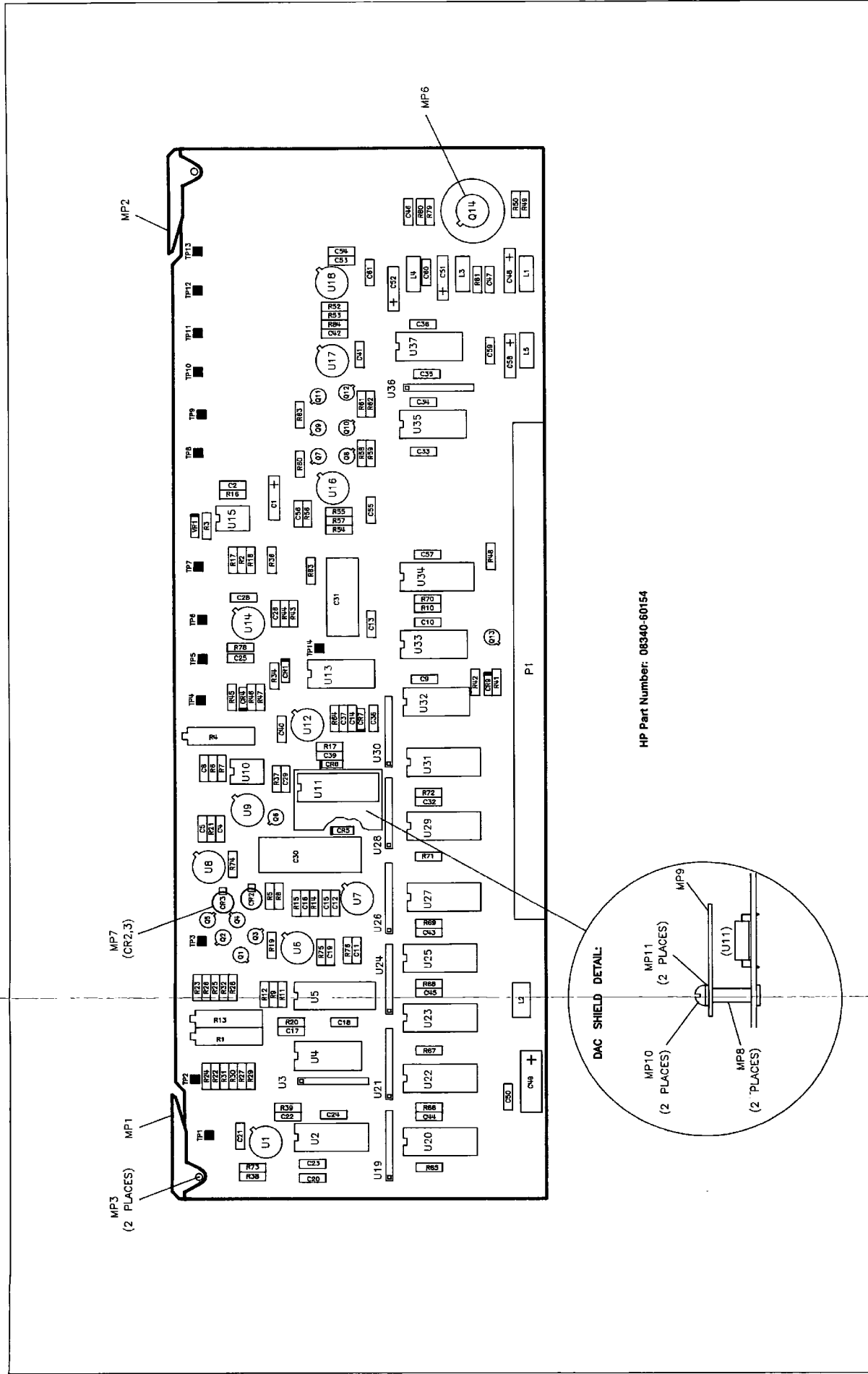

Figure A58-5. A58 Sweep Generator Component Location Diagram
 A58-20 Sweep Generator/YO Loop

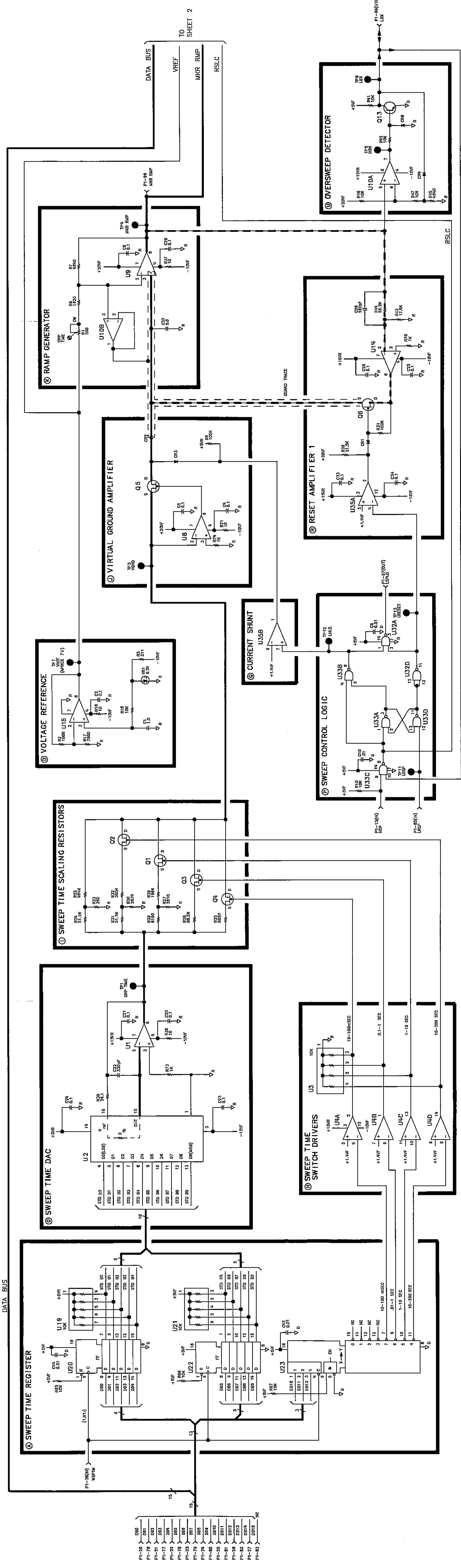

Figure A58-6. A58 Sweep Generator Schematic Diagram (1 of 2)
Sweep Generator/YO Loop A58-21/A58-22

DATA BUS

DATA BUS

DATA BUS

DATA BUS

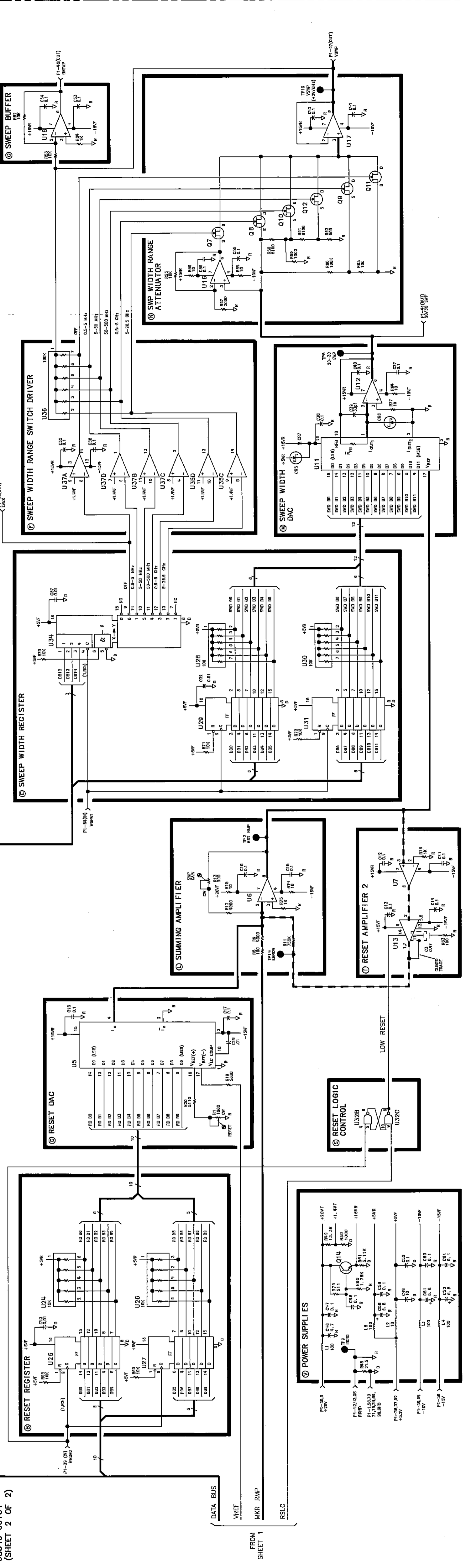

FROM SHEET 1

A58 Sweep Generator Component-Level Troubleshooting

Table A58-2. A58 Sweep Generator Replaceable Parts

Reference Designation	HP Part Number	C D	Qty	Description	Mfr Code	Mfr Part Number
A58	08340-60154	4	1	SWEEP GENERATOR	28480	08340-60154
A58C1	0180-0291	1	1	CAPACITOR-FXD 1UF ±10% 35VDC TA	28480	0180-0291
A58C2	0160-4841	5	38	CAPACITOR-FXD 1UF +80-20% 50VDC CER	28480	0160-4841
A58C3				NOT ASSIGNED		
A58C4	0160-4841	5		CAPACITOR-FXD 1UF +80-20% 50VDC CER	28480	0160-4841
A58C5	0160-4841	5		CAPACITOR-FXD 1UF +80-20% 50VDC CER	28480	0160-4841
A58C6, 7				NOT ASSIGNED		
A58C8	0160-4841	5		CAPACITOR-FXD 1UF +80-20% 50VDC CER	28480	0160-4841
A58C9	0160-4832	4	8	CAPACITOR-FXD 01UF ±10% 100VDC CER	28480	0160-4832
A58C10	0160-4832	4		CAPACITOR-FXD 01UF ±10% 100VDC CER	28480	0160-4832
A58C11	0160-4841	5		CAPACITOR-FXD 1UF +80-20% 50VDC CER	28480	0160-4841
A58C12	0160-4841	5		CAPACITOR-FXD 1UF +80-20% 50VDC CER	28480	0160-4841
A58C13	0160-4841	5		CAPACITOR-FXD 1UF +80-20% 50VDC CER	28480	0160-4841
A58C14	0160-4841	5		CAPACITOR-FXD 1UF +80-20% 50VDC CER	28480	0160-4841
A58C15	0160-4841	5		CAPACITOR-FXD 1UF +80-20% 50VDC CER	28480	0160-4841
A58C16	0160-4841	5		CAPACITOR-FXD 1UF +80-20% 50VDC CER	28480	0160-4841
A58C17	0160-4841	5		CAPACITOR-FXD 1UF +80-20% 50VDC CER	28480	0160-4841
A58C18	0160-4841	5		CAPACITOR-FXD 1UF +80-20% 50VDC CER	28480	0160-4841
A58C19	0160-4832	4		CAPACITOR-FXD 01UF ±10% 100VDC CER	28480	0160-4832
A58C20	0160-4841	5		CAPACITOR-FXD 1UF +80-20% 50VDC CER	28480	0160-4841
A58C21	0160-4841	5		CAPACITOR-FXD 1UF +80-20% 50VDC CER	28480	0160-4841
A58C22	0160-4810	8	1	CAPACITOR-FXD 330PF ±5% 100VDC CER	28480	0160-4810
A58C23	0160-4841	5		CAPACITOR-FXD 1UF +80-20% 50VDC CER	28480	0160-4841
A58C24	0160-4841	5		CAPACITOR-FXD 1UF +80-20% 50VDC CER	28480	0160-4841
A58C25	0160-4841	5		CAPACITOR-FXD 1UF +80-20% 50VDC CER	28480	0160-4841
A58C26	0160-4825	5	1	CAPACITOR-FXD 560PF ±5% 100VDC CER	28480	0160-4825
A58C27				NOT ASSIGNED		
A58C28	0160-4841	5		CAPACITOR-FXD 1UF +80-20% 50VDC CER	28480	0160-4841
A58C29	0160-4841	5		CAPACITOR-FXD 1UF +80-20% 50VDC CER	28480	0160-4841
A58C30	0160-5662	0	1	CAPACITOR-FXD 5UF ±10% 50VDC NET-POLYC	28480	0160-5662
A58C31	0160-4265	7	1	CAPACITOR-FXD 47UF ±20% 50VDC	84411	HEW 386
A58C32	0160-4832	4		CAPACITOR-FXD 01UF ±10% 100VDC CER	28480	0160-4832
A58C33	0160-4841	5		CAPACITOR-FXD 1UF +80-20% 50VDC CER	28480	0160-4841
A58C34	0160-4841	5		CAPACITOR-FXD 1UF +80-20% 50VDC CER	28480	0160-4841
A58C35	0160-4841	5		CAPACITOR-FXD 1UF +80-20% 50VDC CER	28480	0160-4841
A58C36	0160-4841	5		CAPACITOR-FXD 1UF +80-20% 50VDC CER	28480	0160-4841
A58C37	0160-4841	5		CAPACITOR-FXD 1UF +80-20% 50VDC CER	28480	0160-4841
A58C38	0160-4841	5		CAPACITOR-FXD 1UF +80-20% 50VDC CER	28480	0160-4841
A58C39	0160-4807	3	1	CAPACITOR-FXD 33PF ±5% 100VDC CER 0±30	28480	0160-4807
A58C40	0160-4841	5		CAPACITOR-FXD 1UF +80-20% 50VDC CER	28480	0160-4841
A58C41	0160-4841	5		CAPACITOR-FXD 1UF +80-20% 50VDC CER	28480	0160-4841
A58C42	0160-4841	5		CAPACITOR-FXD 1UF +80-20% 50VDC CER	28480	0160-4841
A58C43	0160-4832	4		CAPACITOR-FXD 01UF ±10% 100VDC CER	28480	0160-4832
A58C44	0160-4832	4		CAPACITOR-FXD 01UF ±10% 100VDC CER	28480	0160-4832
A58C45	0160-4832	4		CAPACITOR-FXD 01UF ±10% 100VDC CER	28480	0160-4832
A58C46	0160-4841	5		CAPACITOR-FXD 1UF +80-20% 50VDC CER	28480	0160-4841
A58C47	0160-4841	5		CAPACITOR-FXD 1UF +80-20% 50VDC CER	28480	0160-4841
A58C48	0180-1731	8	1	CAPACITOR-FXD 4 7UF ±10% 50VDC TA	28480	0180-1731
A58C49	0180-0374	3	1	CAPACITOR-FXD 10UF ±10% 20VDC TA	56289	150D106x9020B2
A58C50	0160-4841	5		CAPACITOR-FXD 1UF +80-20% 50VDC CER	28480	0160-4841
A58C51	0180-0116	1	3	CAPACITOR-FXD 6 8UF ±10% 35VDC TA	28480	0180-0116
A58C52	0180-0116	1		CAPACITOR-FXD 6 8UF ±10% 35VDC TA	28480	0180-0116
A58C53	0160-4841	5		CAPACITOR-FXD 1UF +80-20% 50VDC CER	28480	0160-4841
A58C54	0160-4841	5		CAPACITOR-FXD 1UF +80-20% 50VDC CER	28480	0160-4841
A58C55	0160-4841	5		CAPACITOR-FXD 1UF +80-20% 50VDC CER	28480	0160-4841
A58C56	0160-4841	5		CAPACITOR-FXD 1UF +80-20% 50VDC CER	28480	0160-4841
A58C57	0160-4832	4		CAPACITOR-FXD 01UF ±10% 100VDC CER	28480	0160-4832
A58C58	0180-0116	1		CAPACITOR-FXD 6 8UF ±10% 35VDC TA	28480	0180-0116
A58C59	0160-4841	5		CAPACITOR-FXD 1UF +80-20% 50VDC CER	28480	0160-4841
A58C60	0160-4841	5		CAPACITOR-FXD 1UF +80-20% 50VDC CER	28480	0160-4841
A58C61	0160-4841	5		CAPACITOR-FXD 1UF +80-20% 50VDC CER	28480	0160-4841
A58CR1	1901-1098	1	2	DIODE-SWITCHING 1N4150 50V 200MA 4NS	9N171	1N4150
A58CR2	1901-0586	0	9	DIODE-GEN PRP 30V 25MA TO-72	28480	1901-0586
A58CR3	1901-0586	0		DIODE-GEN PRP 30V 25MA TO-72	28480	1901-0586
A58CR4	1901-1098	1		DIODE-SWITCHING 1N4150 50V 200MA 4NS	9N171	1N4150
A58CR5	1901-0518	8	2	DIODE-SM SIG SCHOTTKY	28480	1901-0518

A58 Sweep Generator Component-Level Troubleshooting

Table A58-2 A58 Sweep Generator Replaceable Parts

Reference Designation	HP Part Number	C D	Qty	Description	Mfr Code	Mfr Part Number
A58CR6	1901-0518	8		DIODE-SM SIG SCHOTTKY	28480	1901-0518
A58CR7	1901-0033	2	2	DIODE-GEN PRP 180V 200MA DO-7	28480	1901-0033
A58CR8				NOT ASSIGNED		
A58CR9	1901-0033	2		DIODE-GEN PRP 180V 200MA DO-7	28480	1901-0033
A58L1	9140-0210	1	4	INDUCTOR RF-CH-MLD 100UH 5% 166DX 385LG	28480	9140-0210
A58L2	9100-0539	3	1	INDUCTOR RF-CH-MLD 10UH 5% 156DX 375LG	28480	9100-0539
A58L3	9140-0210	1		INDUCTOR RF-CH-MLD 100UH 5% 166DX 385LG	28480	9140-0210
A58L4	9140-0210	1		INDUCTOR RF-CH-MLD 100UH 5% 166DX 385LG	28480	9140-0210
A58L5	9140-0210	1		INDUCTOR RF-CH-MLD 100UH 5% 166DX 385LG	28480	9140-0210
A58MP1	4040-0753	0	1	EXTR-PC BD GRN POLYC 062-BD-THKNS	28480	4040-0753
A58MP2	4040-0747	2	1	EXTR-PC BD GRA POLYC 062-BD-THKNS	28480	4040-0747
A58MP3	1480-0073	6	2	PIN-ROLL 062-IN-DIA 25-IN-LG BE-CU	28480	1480-0073
A58MP4,5				NOT ASSIGNED		
A58MP6	1205-0011	0	1	HEAT SINK TO-5/TO-39-CS	28480	1205-0011
A58MP7	1200-0172	4	2	INSULATOR-ASTR DAP-GL	28480	1200-0172
A58MP8	0380-1221	5	1	STANDOFF-RUT-ON 25-IN-LG 2-56 THD	28480	0380-1221
A58MP9	08340-00068	3	1	DAC SHIELD	28480	08340-00068
A58MP10	0520-0126	5	1	SCREW-MACH 2-56 125-IN-LG 100DEG	28480	0520-0126
A58MP11	2190-0112	0	1	WASHER LK 088-IN-DIA	28480	2190-0112
A58P1	1251-7469	3	1	CONN - POST TYPE	28480	1251-7469
A58Q1	1855-0420	2	10	TRANSISTOR J-FET 2N4391 N-CHAN D-MODE	01295	2N4391
A58Q2	1855-0420	2		TRANSISTOR J-FET 2N4391 N-CHAN D-MODE	01295	2N4391
A58Q3	1855-0420	2		TRANSISTOR J-FET 2N4391 N-CHAN D-MODE	01295	2N4391
A58Q4	1855-0420	2		TRANSISTOR J-FET 2N4391 N-CHAN D-MODE	01295	2N4391
A58Q5	1855-0278	8	1	TRANSISTOR J-FET 2N5116 P-CHAN D-MODE	17856	2N5116
A58Q6	1855-0386	2		TRANSISTOR J-FET 2N4392 N-CHAN D-MODE	04713	2N4392
A58Q7	1855-0420	2		TRANSISTOR J-FET 2N4391 N-CHAN D-MODE	01295	2N4391
A58Q8	1855-0420	2		TRANSISTOR J-FET 2N4391 N-CHAN D-MODE	01295	2N4391
A58Q9	1855-0420	2		TRANSISTOR J-FET 2N4391 N-CHAN D-MODE	01295	2N4391
A58Q10	1855-0420	2		TRANSISTOR J-FET 2N4391 N-CHAN D-MODE	01295	2N4391
A58Q11	1855-0420	2		TRANSISTOR J-FET 2N4391 N-CHAN D-MODE	01295	2N4391
A58Q12	1855-0420	2		TRANSISTOR J-FET 2N4391 N-CHAN D-MODE	01295	2N4391
A58Q13	1854-0404	0	1	TRANSISTOR NPN SI TO-18 PD=360MW	28480	1854-0404
A58Q14	1854-0361	8	1	TRANSISTOR NPN 2N4239 SI TO-5 PD=6W	02037	2N4239
A58R1	2100-3154	7	1	RESISTOR-TRMR 1K 10% C SIDE-ADJ 17-TRN	02111	43P102
A58R2	0757-0280	3	9	RESISTOR 1K 1% 125W F TC=0±100	24546	C4-1/8-T0-1001-F
A58R3	0757-0416	7	2	RESISTOR 511 1% 125W F TC=0±100	24546	C4-1/8-T0-511R-F
A58R4	2100-3123	0	1	RESISTOR-TRMR 500 10% C SIDE-ADJ 17-TRN	02111	43P501
A58R5	0757-0465	6	3	RESISTOR 100K 1% 125W F TC=0±100	24546	C4-1/8-T0-1003-F
A58R6	0757-0428	1	1	RESISTOR 1 62K 1% 125W F TC=0±100	24546	C4-1/8-T0-1621-F
A58R7	0698-3155	1	2	RESISTOR 4 64K 1% 125W F TC=0±100	24546	C4-1/8-T0-4641-F
A58R8	0757-0401	0	3	RESISTOR 100 1% 125W F TC=0±100	24546	C4-1/8-T0-101F
A58R9	0699-0747	3	2	RESISTOR 4K 05% 1W F TC=0±10	28480	0699-0747
A58R10	0757-0442	9	14	RESISTOR 10K 1% 125W F TC=0±100	24546	C4-1/8-T0-1002-F
A58R11	0698-8960	6	1	RESISTOR 750K 1% 125W F TC=0±100	28480	0698-8960
A58R12	0699-0747	3		RESISTOR 4K 05% 1W F TC=0±10	28480	0699-0747
A58R13	2100-3095	5	1	RESISTOR-TRMR 200 10% C SIDE-ADJ 17-TRN	02111	43P201
A58R14	0757-0346	2	9	RESISTOR 10 1% 125W F TC=0±100	24546	C4-1/8-T0-10R0-F
A58R15	0757-0346	2		RESISTOR 10 1% 125W F TC=0±100	24546	C4-1/8-T0-10R0-F
A58R16	0757-0346	2		RESISTOR 10 1% 125W F TC=0±100	24546	C4-1/8-T0-10R0-F
A58R17	0757-0440	7	1	RESISTOR 7 5K 1% 125W F TC=0±100	24546	C4-1/8-T0-7501-F
A58R18	0757-0442	9		RESISTOR 10K 1% 125W F TC=0±100	24546	C4-1/8-T0-1002-F
A58R19	0757-0200	7	1	RESISTOR 5 62K 1% 125W F TC=0±100	24546	C4-1/8-T0-5621-F
A58R20	0757-0438	3	2	RESISTOR 5 11K 1% 125W F TC=0±100	24546	C4-1/8-T0-5111-F
A58R21	0757-0346	2		RESISTOR 10 1% 125W F TC=0±100	24546	C4-1/8-T0-10R0-F
A58R22	0757-1101	9	1	RESISTOR 360 1% 125W F TC=0±100	24546	C4-1/8-T0-361-F
A58R23	0698-3260	9	1	RESISTOR 464K 1% 125W F TC=0±100	28480	0698-3260
A58R24	0757-0458	7	2	RESISTOR 51 1K 1% 125W F TC=0±100	24546	C4-1/8-T0-5112-F
A58R25	0698-3484	9	1	RESISTOR 6 65K 1% 125W F TC=0±100	24546	C4-1/8-T0-6651-F
A58R26	0698-4503	5	1	RESISTOR 66 5K 1% 125W F TC=0±100	24546	C4-1/8-T0-6652-F
A58R27	0698-0085	0	1	RESISTOR 2 61K 1% 125W F TC=0±100	24546	C4-1/8-T0-2611-F
A58R28	0698-3453	2	1	RESISTOR 196K 1% 125W F TC=0±100	24546	C4-1/8-T0-1963-F
A58R29	0757-0290	5	1	RESISTOR 6 19K 1% 125W F TC=0±100	19701	MF4C1/8-T0-6191-F
A58R30	0698-3151	7	1	RESISTOR 2 87K 1% 125W F TC=0±100	24546	C4-1/8-T0-2871-F

A58 Sweep Generator Component-Level Troubleshooting

Table A58-2. A58 Sweep Generator Replaceable Parts

Reference Designation	HP Part Number	C D	Qty	Description	Mfr Code	Mfr Part Number
A58R31	0757-0458	7	1	RESISTOR 51 1K 1% 125W F TC=0±100	24546	C4-1/8-T0-5112-F
A58R32	0698-5093	0		RESISTOR 390K 1% 125W F TC=0±100	28480	0698-5093
A58R33				NOT ASSIGNED		
A58R34	0757-0465	6	1	RESISTOR 100K 1% 125W F TC=0±100	24546	C4-1/8-T0-1003-F
A58R35				NOT ASSIGNED		
A58R36	0757-0199	3	1	RESISTOR 21 5K 1% 125W F TC=0±100	24546	C4-1/8-T0-2152-F
A58R37	0757-0346	2		RESISTOR 10 1% 125W F TC=0±100	24546	C4-1/8-T0-10R0-F
A58R38	0757-0346	2		RESISTOR 10 1% 125W F TC=0±100	24546	C4-1/8-T0-10R0-F
A58R39	0698-3432	7	1	RESISTOR 26 1 1% 125W F TC=0±100	03888	PME55-1/8-T0-26R1-F
A58R40				NOT ASSIGNED		
A58R41	0757-0442	9	1	RESISTOR 10K 1% 125W F TC=0±100	24546	C4-1/8-T0-1002-F
A58R42	0757-0442	9		RESISTOR 10K 1% 125W F TC=0±100	24546	C4-1/8-T0-1002-F
A58R43	0698-3136	8	1	RESISTOR 17 8K 1% 125W F TC=0±100	24546	C4-1/8-T0-1782-F
A58R44	0757-0459	8		RESISTOR 56 2K 1% 125W F TC=0±100	24546	C4-1/8-T0-5622-F
A58R45	0698-3155	1		RESISTOR 4 64K 1% 125W F TC=0±100	24546	C4-1/8-T0-4641-F
A58R46	0757-0442	9	1	RESISTOR 10K 1% 125W F TC=0±100	24546	C4-1/8-T0-1002-F
A58R47	0757-0442	9		RESISTOR 10K 1% 125W F TC=0±100	24546	C4-1/8-T0-1002-F
A58R48	0698-3430	5	1	RESISTOR 21 5 1% 125W F TC=0±100	03888	PME55-1/8-T0-21R5-F
A58R49	0757-0289	2		RESISTOR 13 3K 1% 125W F TC=0±100	19701	MF4C 1/8-T0-1332-F
A58R50	0757-0280	3		RESISTOR 1K 1% 125W F TC=0±100	24546	C4-1/8-T0-1001-F
A58R51				NOT ASSIGNED		
A58R52	0699-0683	6	3	RESISTOR 10K 01% 1W F TC=0±15	28480	0699-0683
A58R53	0699-0683	6		RESISTOR 10K 01% 1W F TC=0±15	28480	0699-0683
A58R54	0757-0346	2		RESISTOR 10 1% 125W F TC=0±100	24546	C4-1/8-T0-10R0-F
A58R55	0699-0683	6		RESISTOR 10K 01% 1W F TC=0±15	28480	0699-0683
A58R56	0757-0346	2	1	RESISTOR 10 1% 125W F TC=0±100	24546	C4-1/8-T0-10R0-F
A58R57	0699-0685	8		RESISTOR 2K 01% 1W F TC=0±15	28480	0699-0685
A58R58	0699-0684	7	2	RESISTOR 8 1K 01% 1W F TC=0±15	28480	0699-0684
A58R59	0699-0275	2		RESISTOR 1K 01% 1W F TC=0±15	28480	0699-0275
A58R60	0757-0465	6		RESISTOR 100K 1% 125W F TC=0±100	24546	C4-1/8-T0-1003-F
A58R61	0699-0684	7	1	RESISTOR 8 1K 01% 1W F TC=0±15	28480	0699-0684
A58R62	0699-0682	5		RESISTOR 900 01% 1W F TC=0±15	28480	0699-0682
A58R63	0757-0401	0		RESISTOR 100 1% 125W F TC=0±100	24546	C4-1/8-T0-101-F
A58R64	0757-0346	2		RESISTOR 10 1% 125W F TC=0±100	24546	C4-1/8-T0-10R0-F
A58R65	0757-0442	9		RESISTOR 10K 1% 125W F TC=0±100	24546	C4-1/8-T0-1002-F
A58R66	0757-0442	9	1	RESISTOR 10K 1% 125W F TC=0±100	24546	C4-1/8-T0-1002-F
A58R67	0757-0442	9		RESISTOR 10K 1% 125W F TC=0±100	24546	C4-1/8-T0-1002-F
A58R68	0757-0442	9		RESISTOR 10K 1% 125W F TC=0±100	24546	C4-1/8-T0-1002-F
A58R69	0757-0442	9		RESISTOR 10K 1% 125W F TC=0±100	24546	C4-1/8-T0-1002-F
A58R70	0757-0442	9		RESISTOR 10K 1% 125W F TC=0±100	24546	C4-1/8-T0-1002-F
A58R71	0757-0442	9	1	RESISTOR 10K 1% 125W F TC=0±100	24546	C4-1/8-T0-1002-F
A58R72	0757-0442	9		RESISTOR 10K 1% 125W F TC=0±100	24546	C4-1/8-T0-1002-F
A58R73	0757-0280	3		RESISTOR 1K 1% 125W F TC=0±100	24546	C4-1/8-T0-1001-F
A58R74	0757-0280	3		RESISTOR 1K 1% 125W F TC=0±100	24546	C4-1/8-T0-1001-F
A58R75	0757-0280	3	1	RESISTOR 1K 1% 125W F TC=0±100	24546	C4-1/8-T0-1001-F
A58R76	0757-0280	3		RESISTOR 1K 1% 125W F TC=0±100	24546	C4-1/8-T0-1001-F
A58R77	0757-0280	3		RESISTOR 1K 1% 125W F TC=0±100	24546	C4-1/8-T0-1001-F
A58R78	0757-0280	3		RESISTOR 1K 1% 125W F TC=0±100	24546	C4-1/8-T0-1001-F
A58R79	0757-0416	7		RESISTOR 511 1% 125W F TC=0±100	24546	C4-1/8-T0-511R-F
A58R80	0757-0278	9	1	RESISTOR 1 78K 1% 125W F TC=0±100	24546	C4-1/8-T0-1781-F
A58R81	0757-0438	3		RESISTOR 5 11K 1% 125W F TC=0±100	24546	C4-1/8-T0-5111-F
A58R82				NOT ASSIGNED		
A58R83	0757-0401	0		RESISTOR 100 1% 125W F TC=0±100	24546	C4-1/8-T0-101-F
A58R84	0757-0280	3		RESISTOR 1K 1% 125W F TC=0±100	24546	C4-1/8-T0-1001-F
A58TP1	0360-0535	0	14	TERMINAL TEST POINT PCB	00000	ORDER BY DESCRIPTION
A58TP2	0360-0535	0		TERMINAL TEST POINT PCB	00000	ORDER BY DESCRIPTION
A58TP3	0360-0535	0		TERMINAL TEST POINT PCB	00000	ORDER BY DESCRIPTION
A58TP4	0360-0535	0		TERMINAL TEST POINT PCB	00000	ORDER BY DESCRIPTION
A58TP5	0360-0535	0		TERMINAL TEST POINT PCB	00000	ORDER BY DESCRIPTION
A58TP6	0360-0535	0		TERMINAL TEST POINT PCB	00000	ORDER BY DESCRIPTION
A58TP7	0360-0535	0		TERMINAL TEST POINT PCB	00000	ORDER BY DESCRIPTION
A58TP8	0360-0535	0		TERMINAL TEST POINT PCB	00000	ORDER BY DESCRIPTION
A58TP9	0360-0535	0		TERMINAL TEST POINT PCB	00000	ORDER BY DESCRIPTION
A58TP10	0360-0535	0		TERMINAL TEST POINT PCB	00000	ORDER BY DESCRIPTION
A58TP11	0360-0535	0		TERMINAL TEST POINT PCB	00000	ORDER BY DESCRIPTION
A58TP12	0360-0535	0		TERMINAL TEST POINT PCB	00000	ORDER BY DESCRIPTION
A58TP13	0360-0535	0		TERMINAL TEST POINT PCB	00000	ORDER BY DESCRIPTION
A58TP14	0360-0535	0		TERMINAL TEST POINT PCB	00000	ORDER BY DESCRIPTION

A58 Sweep Generator Component-Level Troubleshooting

Table A58-2. A58 Sweep Generator Replaceable Parts

Reference Designation	HP Part Number	C D	Qty	Description	Mfr Code	Mfr Part Number
A58U1	1826-1048	1	9	IC OP AMP LOW-DRIFT TO-99 PKG	28480	1826-1048
A58U2	1820-1984	2	1	IC CONV 10-B-D/A 16-DIP-C PKG	24355	AD561KD
A58U3	1810-0206	8	7	NETWORK-RES 8-SIP10 0K OHM X 7	01121	208A103
A58U4	1826-0138	8	3	IC COMPARTOR GP QUAD 14-DIP-P PKG	01295	LM339N
A58U5	1826-0938	6	1	D/A 10-bit 18-CERDIP BPLR	28480	1826-0938
A58U6	1826-1048	1		IC OP AMP LOW-DRIFT TO-99 PKG	28480	1826-1048
A58U7	1826-1048	1		IC OP AMP LOW-DRIFT TO-99 PKG	28480	1826-1048
A58U8	1826-1048	1		IC OP AMP LOW-DRIFT TO-99 PKG	28480	1826-1048
A58U9	1813-0041	5	1	IC OP AMP TO-99 PKG	27014	LH0042CH
A58U10	1826-0785	1	1	IC OP AMP LOW-BIAS-H-IMP DUAL 8-DIP-C	01295	TL072ACJG
A58U11	1826-0684	9	1	IC CONV 12-B-D/A 18 DIP-C PKG	28480	1826-0684
A58U12	1826-1048	1		IC OP AMP LOW-DRIFT TO-99 PKG	28480	1826-1048
A58U13	1826-1140	4	1	IC SMPL/HOLD 14 CERDIP	02180	SMP-10FT
A58U14	1826-0471	2		IC OP AMP LOW-DRIFT TO-99 PKG	28480	1826-0471
A58U15	1826-0783	9	1	IC OP AMP LOW-NOIS 8-DIP-C PKG	52063	XR5534ACN
A58U16	1826-1048	1		IC OP AMP LOW-DRIFT TO-99 PKG	28480	1826-1048
A58U17	1826-1048	1		IC OP AMP LOW-DRIFT TO-99 PKG	28480	1826-1048
A58U18	1826-1048	1		IC OP AMP LOW-DRIFT TO-99 PKG	28480	1826-1048
A58U19	1810-0206	8		NETWORK-RES 8-SIP10 0K OHM X 7	01121	208A103
A58U20	1820-1196	8	6	IC FF TTL LS D-TYPE POS-EDGE-TRIG COM	01295	SN74LS174N
A58U21	1810-0206	8		NETWORK-RES 8-SIP10 0K OHM X 7	01121	208A103
A58U22	1820-1196	8		IC FF TTL LS D-TYPE POS-EDGE-TRIG COM	01295	SN74LS174N
A58U23	1820-2550	0	2	IC DCDR TTL LS 3-TO-8-LINE	01295	SN74LS137N
A58U24	1810-0206	8		NETWORK-RES 8-SIP10 0K OHM X 7	01121	208A103
A58U25	1820-1196	8		IC FF TTL LS D-TYPE POS-EDGE-TRIG COM	01295	SN74LS174N
A58U26	1810-0206	8		NETWORK-RES 8-SIP10 0K OHM X 7	01121	208A103
A58U27	1820-1196	8		IC FF TTL LS D-TYPE POS-EDGE-TRIG COM	01295	SN74LS174N
A58U28	1810-0206	8		NETWORK-RES 8-SIP10 0K OHM X 7	01121	208A103
A58U29	1820-1196	8		IC FF TTL LS D-TYPE POS-EDGE-TRIG COM	01295	SN74LS174N
A58U30	1810-0206	8		NETWORK-RES 8-SIP10 0K OHM X 7	01121	208A103
A58U31	1820-1196	8		IC FF TTL LS D-TYPE POS-EDGE-TRIG COM	01295	SN74LS174N
A58U32	1820-1197	9	1	IC GATE TTL LS NAND QUAD 2-INP	01295	SN74LS00N
A58U33	1820-1425	6	1	IC SCHMITT-TRIG TTL LS NAND QUAD 2-INP	01295	SN74LS132N
A58U34	1820-2550	0		IC DCDR TTL LS 3-TO-8-LINE	01295	SN74LS137N
A58U35	1826-0138	8		IC COMPARTOR GP QUAD 14-DIP-P PKG	01295	LM339N
A58U36	1810-0371	8	1	NETWORK-RES 8-SIP100 0K OHM X7	01121	208A104
A58U37	1826-0138	8		IC COMPARTOR GP QUAD 14-DIP-P PKG	01295	LM339N
A58VR1	1902-0625	0	1	DIODE-ZNR 1N829 6 2V 5% DO-7 PD= 25W	04713	1N829

A60 Processor Circuit Description

ASSEMBLY PURPOSE

The A60 processor assembly performs all instrument data processing. This assembly consist of:

- A microprocessor
- Memory
- An HP-IB interface
- The necessary circuitry for:
 - Clock generation
 - Address and memory decoding
 - Buffering
 - Interrupt handling

The microprocessor interfaces directly with memory, which consists of:

- 32K words of Ultra Violet Erasable Programmable Read Only Memory (UVEPROM)

The instrument software program (firmware) is stored in this section of memory, with the default calibration data.

- 2K words of Electrically Erasable Programmable Read Only Memory (EEPROM)

Protected calibration data is stored here.

- 8K words of Random Access Memory (RAM)

Working calibration data and SAVE/RECALL register values are stored here. Battery backup provides power to RAM when AC power is disconnected. If the backup power fails, working calibration data and SAVE/RECALL information is lost. When AC power is restored, the EEPROM calibration data is loaded in RAM, and the front panel displays CALIBRATION RESTORED.

NOTE: 1 word = 2 bytes; 1 byte = 8 bits.

The microprocessor is controlled by the firmware stored in memory. With this program, the microprocessor can transfer data (I/O addressing) and internally process data it has accessed. All data transfers go through the microprocessor.

The A60 processor assembly communicates with the rest of the instrument by means of the internal address and data busses. External communication is through the HP-IB connection on the rear panel. The HP-IB interface circuitry provides the link between the internal instrument bus and the external HP-IB interface.

MEMORY (BLOCKS A, B, and C)

UVEPROM (block A) has 32K words of programmed firmware that contains the complete instrument operating program.

EEPROM (block B) has 2K words of electrically alterable memory that contains protected calibration data (calibration constants).

RAM (block C) has 8K words of volatile memory that is used for working calibration data and SAVE/RECALL registers. Block G provides battery backup for RAM if line power is disconnected.

TIMER/SELF TEST INDICATOR/DSA (BLOCK D)

This block contains a counter-timer and a parallel interface adapter for:

- RUN/STOP indication for the instrument microprocessor.
- Test output signals for the test LEDs.
- Interrupts with timer countdown.
- Control points for testing and for DSA:

TP1	Non-destructive RAM testing
TP2 — 5	DSA controls
TP6	Status line control for RAM testing

I/O DECODING AND CONTROL (BLOCK E)

The I/O decoder consists of two PLA (programmable logic array) devices that form a state machine for I/O bus control. Address and control lines develop the output control signal state equations (AND/OR/INVERSION).

The I/O decoder outputs provide control for the I/O data bus buffers (block N), the I/O address bus buffer (block P), and the HP-IB interface (block M).

SELF TEST (BLOCK F)

The self test registers interface the instrument data and address busses to the I/O data and address busses. Both the address and data lines are checked as follows:

- **Address.** An I/O bus transfer is initiated with the I/O address latched onto the address register. Using control lines, the instrument microprocessor monitors the address under test.
- **Data.** I/O data is latched into the buffers and checked by the microprocessor.

POWER SUPPLIES (BLOCK G)

The main instrument power supplies provide the inputs to the A60 assembly. The +22 VDC supply is the standby supply when the instrument is plugged in, and provides RAM voltage during standby and normal operation.

When the instrument is unplugged, the battery (BT1) provides power to maintain calibration constant information in RAM.

The +1.2 VDC supply provides comparator reference voltage for the A60 assembly POWER UP/ STOP circuitry.

Supply power from capacitors C3 and C5 allow the microprocessor to complete operations and set registers and memory if main instrument power is disconnected or lost.

MEMORY DECODING (BLOCK H)

The memory decoder is a PLA (programmable logic array) that uses address and control lines to create the PLA equations for proper memory address locations.

Output control lines are derived from the AND/OR/INVERSION combinations of the input lines. The memory decoding controls the UVEPROM, EEPROM, RAM, and I/O addressing, according to the memory map in Figure A60-1.

CLOCK (BLOCK I)

The crystal output (approximately 14.75 MHz) is shaped by an RC series circuit for waveshaping and RFI elimination, and divided-by-two by a flip-flop to provide the main output clock signals (LCLK and CLK).

The 7.4 MHz clock signals are again divided-by-two for the HP-IB clock signal (approximately 3.6 MHz).

INTERRUPT ENCODER (BLOCK J)

An 8-to-3 encoder provides three level-interrupt signals to the microprocessor. The least significant input is connected to ground, which maintains the encoder outputs high when no interrupts are pending.

PROCESSOR MEMORY MAP

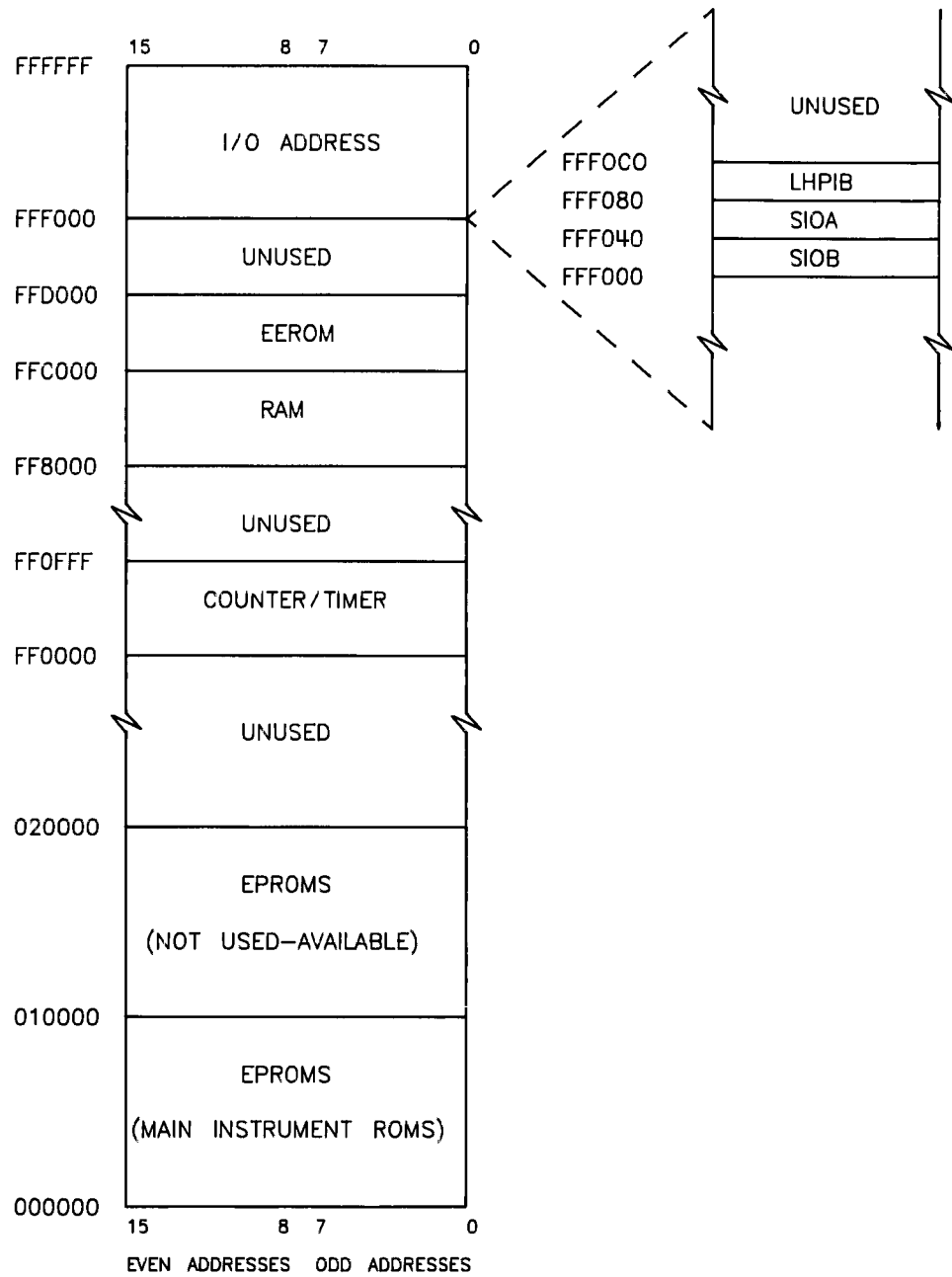
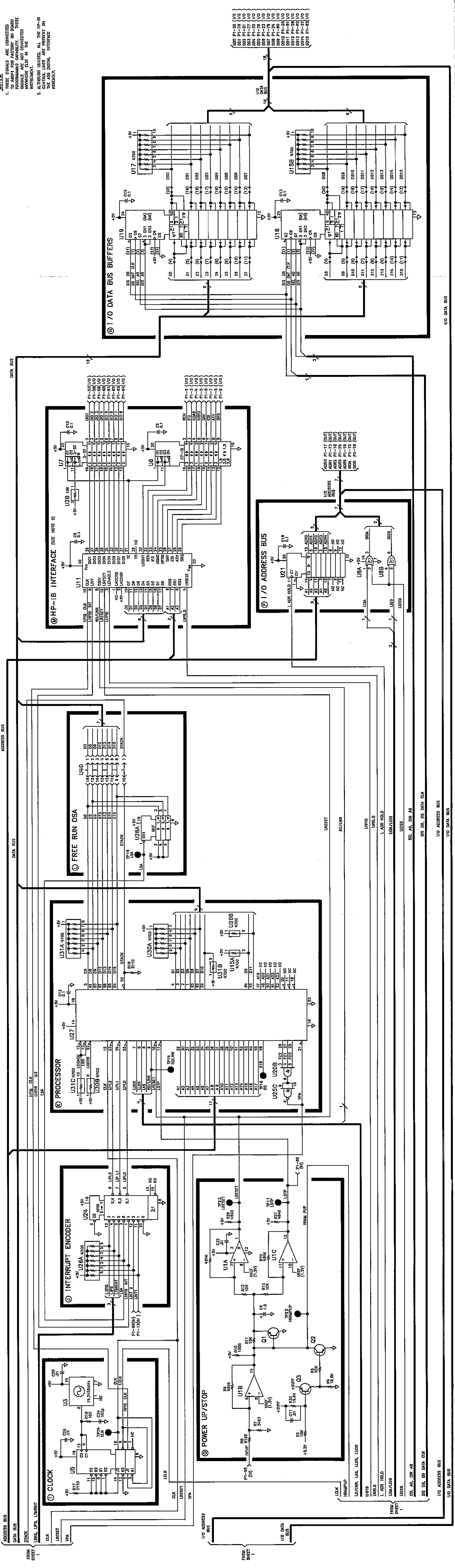
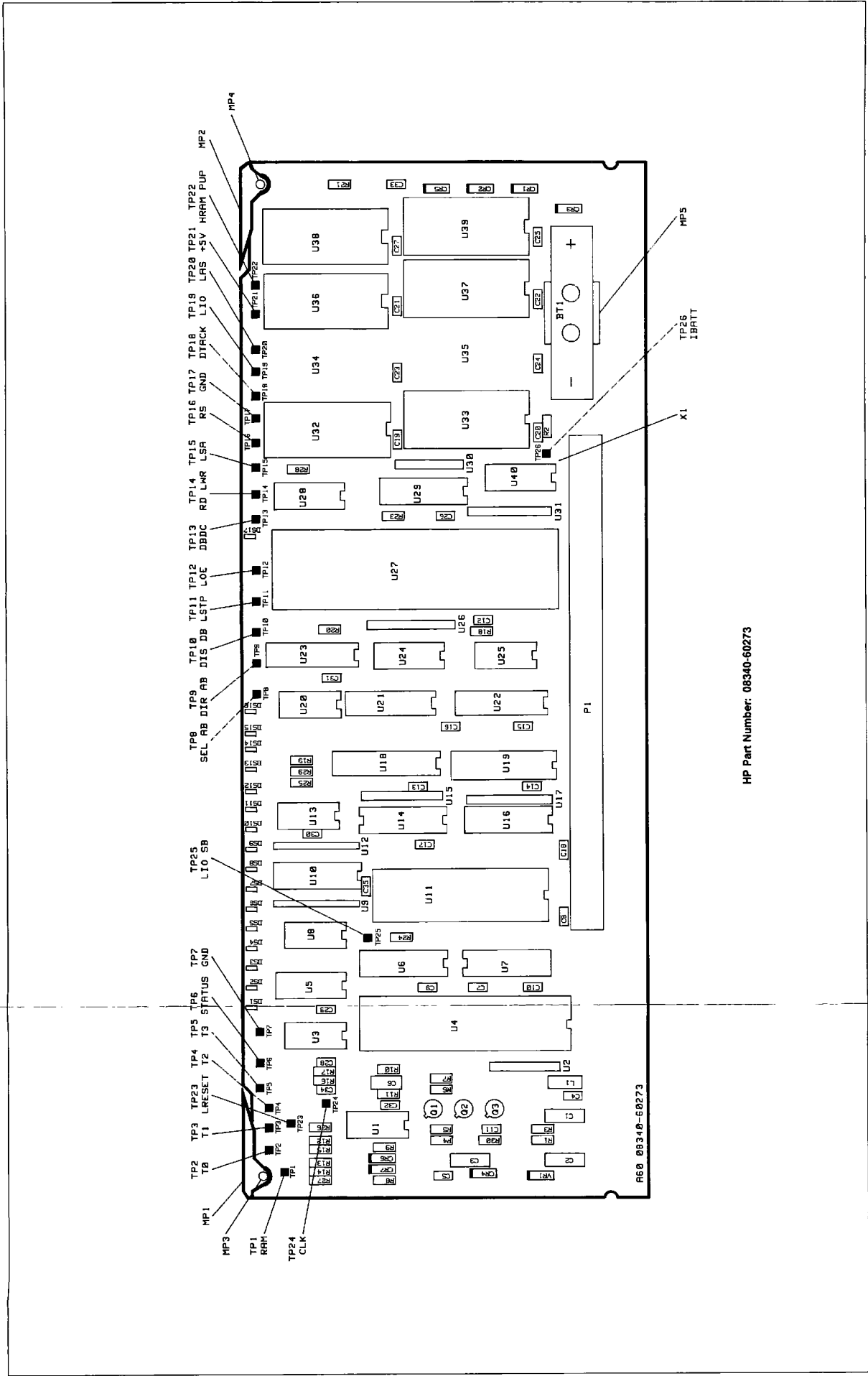

Figure A60-1. Microprocessor Memory Map



NOTES:
 1. THESE SIGNALS ARE CONNECTED TO A601 FOR FACTORY ON BOARD PROGRAMMING CAPABILITY. THESE SIGNALS ARE NOT CONNECTED TO A601 IN THE INSTRUMENT.
 2. ALTHOUGH UNUSED, ALL THE HP-IB CONTROL LINES ARE PRESENT ON THE A60 DIGITAL INTERFACE ASSEMBLY.

Figure A60-5. A60 Processor Schematic Diagram (2 of 2) Controller A60-29/A60-30



HP Part Number: 08340-60273

Figure A60-5. A60 Processor, Component Location Diagram
A60-30 Controller

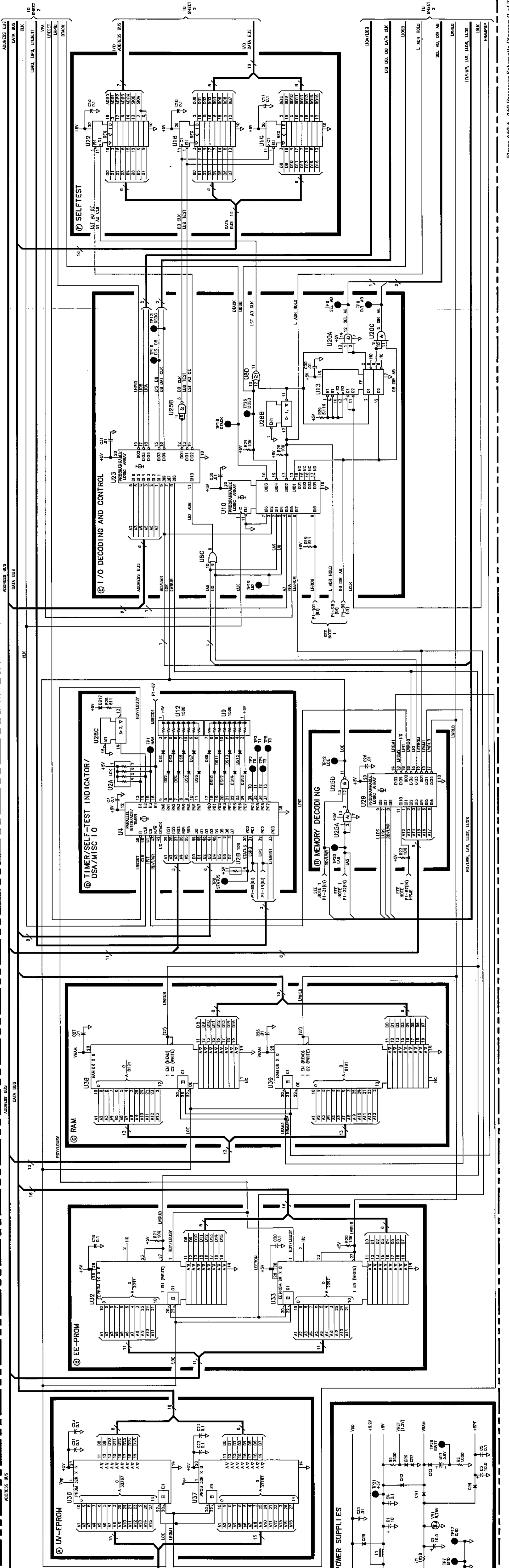

Figure A60-6. A60 Processor Schematic Diagram (1 of 2)

A60 Processor Component-Level Troubleshooting

Table A60-7. A60 Processor Replaceable Parts

Reference Designation	HP Part Number	C D	Qty	Description	Mfr Code	Mfr Part Number
A60	08340-60273	8	1	PROCESSOR ASSEMBLY	28480	08340-60273
A60BT1	1420-0331	3	1	BATTERY 3.4V 1.75A-HR LITHIUM THIONYL	28480	1420-0331
A60C1	0180-0374	3	3	CAPACITOR-FXD 10UF ± 10% 20VDC TA	56289	150D106X9020B2
A60C2	0180-0374	3		CAPACITOR-FXD 10UF ± 10% 20VDC TA	56289	150D106X9020B2
A60C3	0180-0374	3		CAPACITOR-FXD 10UF ± 10% 20VDC TA	56289	150D106X9020B2
A60C4	0160-4835	7	19	CAPACITOR-FXD 1UF ± 10% 50VDC CER	28480	0160-4835
A60C5	0160-4835	7		CAPACITOR-FXD 1UF ± 10% 50VDC CER	28480	0160-4835
A60C6	0180-0291	3	1	CAPACITOR-FXD 1UF ± 10% 35VDC TA	56289	150D105X9035A2
A60C7	0160-4835	7		CAPACITOR-FXD 1UF ± 10% 50VDC CER	28480	0160-4835
A60C8	0160-4835	7		CAPACITOR-FXD 1UF ± 10% 50VDC CER	28480	0160-4835
A60C9	0160-4835	7		CAPACITOR-FXD 1UF ± 10% 50VDC CER	28480	0160-4835
A60C10	0160-4835	7		CAPACITOR-FXD 1UF ± 10% 50VDC CER	28480	0160-4835
A60C11	0160-4832	4	11	CAPACITOR-FXD 01UF ± 10% 100VDC CER	28480	0160-4832
A60C12	0160-4835	7		CAPACITOR-FXD 1UF ± 10% 50VDC CER	28480	0160-4835
A60C13	0160-4835	7		CAPACITOR-FXD 1UF ± 10% 50VDC CER	28480	0160-4835
A60C14	0160-4835	7		CAPACITOR-FXD 1UF ± 10% 50VDC CER	28480	0160-4835
A60C15	0160-4835	7		CAPACITOR-FXD 1UF ± 10% 50VDC CER	28480	0160-4835
A60C16	0160-4835	7		CAPACITOR-FXD 1UF ± 10% 50VDC CER	28480	0160-4835
A60C17	0160-4835	7		CAPACITOR-FXD 1UF ± 10% 50VDC CER	28480	0160-4835
A60C18	0160-4835	7		CAPACITOR-FXD 1UF ± 10% 50VDC CER	28480	0160-4835
A60C19	0160-4835	7		CAPACITOR-FXD 1UF ± 10% 50VDC CER	28480	0160-4835
A60C20	0160-4835	7		CAPACITOR-FXD 1UF ± 10% 50VDC CER	28480	0160-4835
A60C21	0160-4835	7		CAPACITOR-FXD 1UF ± 10% 50VDC CER	28480	0160-4835
A60C22	0160-4835	7		CAPACITOR-FXD 1UF ± 10% 50VDC CER	28480	0160-4835
A60C23	0160-4835	7		CAPACITOR-FXD 1UF ± 10% 50VDC CER	28480	0160-4835
A60C24	0160-4835	7		CAPACITOR-FXD 1UF ± 10% 50VDC CER	28480	0160-4835
A60C25	0160-4832	4		CAPACITOR-FXD 01UF ± 10% 100VDC CER	28480	0160-4832
A60C26	0160-4832	4		CAPACITOR-FXD 01UF ± 10% 100VDC CER	28480	0160-4832
A60C27	0160-4832	4		CAPACITOR-FXD 01UF ± 10% 100VDC CER	28480	0160-4832
A60C28	0160-4832	4		CAPACITOR-FXD 01UF ± 10% 100VDC CER	28480	0160-4832
A60C29	0160-4832	4		CAPACITOR-FXD 01UF ± 10% 100VDC CER	28480	0160-4832
A60C30	0160-4832	4		CAPACITOR-FXD 01UF ± 10% 100VDC CER	28480	0160-4832
A60C31	0160-4832	4		CAPACITOR-FXD 01UF ± 10% 100VDC CER	28480	0160-4832
A60C32	0160-4832	4		CAPACITOR-FXD 01UF ± 10% 100VDC CER	28480	0160-4832
A60C33	0160-4832	4		CAPACITOR-FXD 01UF ± 10% 100VDC CER	28480	0160-4832
A60C34	0160-4801	7	1	CAPACITOR-FXD 100PF ± 5% 100VDC CER	28480	0160-4801
A60C35	0160-4832	4		CAPACITOR-FXD 01UF ± 10% 100VDC CER	28480	0160-4832
A60CR1	1901-0376	6	2	DIODE-GEN PRP 35V 50MA DO-35	28480	1901-0376
A60CR2	1901-0376	6		DIODE-GEN PRP 35V 50MA DO-35	28480	1901-0376
A60CR3	1901-0518	8	1	DIODE-SM SIG SCHOTTKY	28480	1901-0518
A60CR4	1901-0050	3	2	DIODE-SWITCHING 80V 200MA 2NS DO-35	28480	1901-0050
A60CR5	1901-0050	3		DIODE-SWITCHING 80V 200MA 2NS DO-35	28480	1901-0050
A60CR6	1901-1098	1	2	DIODE-SWITCHING 50V 200MA 4NS	02682	1N4150
A60CR7	1901-1098	1		DIODE-SWITCHING 50V 200MA 4NS	02682	1N4150
A60DS1	1990-1149	0	16	LED-LAMP IF=7MA-MAX BVR=5V	28480	1990-1149
A60DS2	1990-1149	0		LED-LAMP IF=7MA-MAX BVR=5V	28480	1990-1149
A60DS3	1990-1149	0		LED-LAMP IF=7MA-MAX BVR=5V	28480	1990-1149
A60DS4	1990-1149	0		LED-LAMP IF=7MA-MAX BVR=5V	28480	1990-1149
A60DS5	1990-1149	0		LED-LAMP IF=7MA-MAX BVR=5V	28480	1990-1149
A60DS6	1990-1149	0		LED-LAMP IF=7MA-MAX BVR=5V	28480	1990-1149
A60DS0	1990-1149	0		LED-LAMP IF=7MA-MAX BVR=5V	28480	1990-1149
A60DS8	1990-1149	0		LED-LAMP IF=7MA-MAX BVR=5V	28480	1990-1149
A60DS9	1990-1149	0		LED-LAMP IF=7MA-MAX BVR=5V	28480	1990-1149
A60DS10	1990-1149	0		LED-LAMP IF=7MA-MAX BVR=5V	28480	1990-1149
A60DS11	1990-1149	0		LED-LAMP IF=7MA-MAX BVR=5V	28480	1990-1149
A60DS12	1990-1149	0		LED-LAMP IF=7MA-MAX BVR=5V	28480	1990-1149
A60DS13	1990-1149	0		LED-LAMP IF=7MA-MAX BVR=5V	28480	1990-1149
A60DS14	1990-1149	0		LED-LAMP IF=7MA-MAX BVR=5V	28480	1990-1149
A60DS15	1990-1149	0		LED-LAMP IF=7MA-MAX BVR=5V	28480	1990-1149
A60DS16	1990-1149	0		LED-LAMP IF=7MA-MAX BVR=5V	28480	1990-1149
A60DS17	1990-1148	9	1	LED-LAMP LUM-INT=1MCD IF=20MA-MAX BVR=5V	28480	1990-1148
A60L1	9100-1788	6	1	CHOKE-WIDE BAND ZMAX=680 OHM@ 180 MHZ	02114	VK200 20/48
A60MP1	4040-0754	1	1	EXTR PC BD BLU	28480	4040-0754
A60MP2	4040-0748	3	1	EXTR PC BD BLK	28480	4040-0748
A60MP3,4	1480-0073	6	2	PIN-ROLL 062-IN-DIA 25-IN-LG BE-CU	28480	1480-0073
A60MP5	1400-1267	4	1	CLIP BTRY AA	28480	1400-1267
A60P1	1251-7469	3	1	CONN-POST TYFE 100-PIN-SPCG 110-CONT	28480	1251-7469
A60Q1	1853-0281	9	2	TRANSISTOR PNP 2N2907A SI TO-18 PD=400MW	04713	2N2907A
A60Q2	1854-0477	7	1	TRANSISTOR NPN 2N2222A SI TO-18 PD=500MW	04713	2N2222A
A60Q3	1853-0281	9		TRANSISTOR PNP 2N2907A SI TO-18 PD=400MW	04713	2N2907A

A60 Processor Component-Level Troubleshooting

Table A60-7. A60 Processor Replaceable Parts

Reference Designation	HP Part Number	C	D	Qty	Description	Mfr Code	Mfr Part Number
A60R1	0757-0873	0		1	RESISTOR 1 62K 1% 5W F TC=0±100	28480	0757-0873
A60R2	0757-0280	3		2	RESISTOR 1K 1% 125W F TC=0±100	24546	C4-1/8-T0-1001-F
A60R3	0757-0442	9		10	RESISTOR 10K 1% 125W F TC=0±100	24546	C4-1/8-T0-1002-F
A60R4	0698-3157	3		2	RESISTOR 19 6K 1% 125W F TC=0±100	24546	C4-1/8-T0-1962-F
A60R5	0757-0442	9			RESISTOR 10K 1% 125W F TC=0±100	24546	C4-1/8-T0-1002-F
A60R6	0757-0290	5		1	RESISTOR 6 19K 1% 125W F TC=0±100	19701	MF4C1/8-T0-6191-F
A60R7	0698-3152	8		1	RESISTOR 3 48K 1% 125W F TC=0±100	24546	C4-1/8-T0-3481-F
A60R8	0698-3153	9		1	RESISTOR 3 83K 1% 125W F TC=0±100	24546	C4-1/8-T0-3831-F
A60R9	0698-3260	9		3	RESISTOR 464K 1% 125W F TC=0±100	28480	0698-3260
A60R10	0757-0280	3			RESISTOR 1K 1% 125W F TC=0±100	24546	C4-1/8-T0-1001-F
A60R11	0757-0442	9			RESISTOR 10K 1% 125W F TC=0±100	24546	C4-1/8-T0-1002-F
A60R12	0757-0442	9			RESISTOR 10K 1% 125W F TC=0±100	24546	C4-1/8-T0-1002-F
A60R13	0757-0442	9			RESISTOR 10K 1% 125W F TC=0±100	24546	C4-1/8-T0-1002-F
A60R14	0698-3260	9			RESISTOR 464K 1% 125W F TC=0±100	28480	0698-3260
A60R15	0698-3260	9			RESISTOR 464K 1% 125W F TC=0±100	28480	0698-3260
A60R16	0757-0401	0		1	RESISTOR 100 1% 125W F TC=0±100	24546	C4-1/8-T0-101-F
A60R17	0757-0438	3		3	RESISTOR 5 11K 1% 125W F TC=0±100	24546	C4-1/8-T0-5111-F
A60R18	0757-0438	3			RESISTOR 5 11K 1% 125W F TC=0±100	24546	C4-1/8-T0-5111-F
A60R19	0757-0416	7		2	RESISTOR 511 1% 125W F TC=0±100	24546	C4-1/8-T0-5111R-F
A60R20	0757-0442	9			RESISTOR 10K 1% 125W F TC=0±100	24546	C4-1/8-T0-1002-F
A60R21	0757-0442	9			RESISTOR 10K 1% 125W F TC=0±100	24546	C4-1/8-T0-1002-F
A60R22					NOT ASSIGNED		
A60R23	0757-0442	9			RESISTOR 10K 1% 125W F TC=0±100	24546	C4-1/8-T0-1002-F
A60R24	0757-0442	9			RESISTOR 10K 1% 125W F TC=0±100	24546	C4-1/8-T0-1002-F
A60R25	0757-0442	9			RESISTOR 10K 1% 125W F TC=0±100	24546	C4-1/8-T0-1002-F
A60R26	0698-3155	1		2	RESISTOR 4 64K 1% 125W F TC=0±100	24546	C4-1/8-T0-4641-F
A60R27	0698-3155	1			RESISTOR 4 64K 1% 125W F TC=0±100	24546	C4-1/8-T0-4641-F
A60R28	0757-0416	7			RESISTOR 511 1% 125W F TC=0±100	24546	C4-1/8-T0-5111R-F
A60R29	0757-0438	3			RESISTOR 5 11K 1% 125W F TC=0±100	24546	C4-1/8-T0-5111-F
A60R30	0698-3157	3			RESISTOR 19 6K 1% 125W F TC=0±100	24546	C4-1/8-T0-1962-F
A60TP1-TP26	0360-0535	0		26	TERMINAL TEST POINT PCB	00000	ORDER BY DESCRIPTION
A60U1	1826-0759	9		1	IC COMPARATOR GP QUAD 14-DIP-C PKG	04713	LM339J
A60U2	1810-0206	8		1	NETWORK-RES 8-SIP10 0K OHM X 7	01121	208A103
A60U3	1813-0196	1		1	XTAL-CLOCK-OSCILLATOR 14 7456-MHZ	28480	1813-0196
A60U4	1820-3449	8		1	IC-PARALLEL INTERFACE/TIMER/8MHZ/JMC68000	28480	1820-3449
A60U5	1820-3172	4		1	IC FF CMOS/74HC J-K BAR POS-EDGE-TRIG	28480	1820-3172
A60U6	1820-3513	7		1	IC TRANSCEIVER TTL S INSTR-BUS IEEE-488	27014	BS75161AN
A60U7	1820-3431	8		1	IC TRANSCEIVER TTL S INSTR-BUS IEEE-488	27014	BS75160AN
A60U8	1820-3401	2		1	IC BFR TTL ALS OR QUAD 2-INP	28480	1820-3401
A60U9	1810-0276	2		2	NETWORK-RES 10-SIP1 5K OHM X 9	01121	210A152
A60U10	08340-80005	6		1	IO DECODER	28480	08340-80005
A60U11	1820-2548	6		1	IC GENERAL PURPOSE INTERFACE BUS ADAPTER	28480	1820-2548
A60U12	1810-0276	2			NETWORK-RES 10-SIP1 5K OHM X 9	01121	210A152
A60U13	1820-1112	8		1	IC FF TTL LS D-TYPE POS-EDGE-TRIG	01295	SN74LS74AN
A60U14	1820-1997	7		3	IC FF TTL LS D-TYPE POS-EDGE-TRIG PRL-IN	01295	SN74LS374N
A60U15	1810-0279	5		4	NETWORK-RES 10-SIP4 7K OHM X 9	01121	210A472
A60U16	1820-1997	7			IC FF TTL LS D-TYPE POS-EDGE-TRIG PRL-IN	01295	SN74LS374N
A60U17	1810-0279	5			NETWORK-RES 10-SIP4 7K OHM X 9	01121	210A472
A60U18	1820-2675	0		2	IC RCVR TTL LS BUS OCTL	01295	SN74LS646N
A60U19	1820-2675	0			IC RCVR TTL LS BUS OCTL	01295	SN74LS646N
A60U20	1820-1203	8		1	IC GATE TTL LS AND TPL 3-INP	01295	SN74LS11N
A60U21	1820-2102	8		1	IC LCH TTL LS D-TYPE OCTL	01295	SN74LS373N
A60U22	1820-1997	7			IC FF TTL LS D-TYPE POS-EDGE-TRIG PRL-IN	01295	SN74LS374N
A60U23	08340-80007	8		1	DECODER	28480	08340-80007
A60U24	1820-1851	2		1	IC ENCDR TTL LS	01295	SN74LS148N
A60U25	1820-2656	7		1	IC GATE TTL ALS NAND QUAD 2-INP	01295	SN74ALS00N
A60U26	1810-0279	5			NETWORK-RES 10-SIP4 7K OHM X 9	01121	210A472
A60U27	1820-2505	5		1	IC -MPU, CLK FREQ=8MHZ, INSTRUCTION	28480	1820-2505
A60U28	1820-1492	7		1	IC BFR TTL LS INV HEX 1-INP	01698	SN74LS368AN
A60U29	08340-80006	7		1	MEMORY DECODER	28480	08340-80006
A60U30	1810-0205	7		1	NETWORK-RES 8-SIP4 7K OHM X 7	01121	208A472
A60U31	1810-0279	5			NETWORK-RES 10-SIP4 7K OHM X 9	01121	210A472
A60U32	1818-3464	2		2	IC EPROM 2K X8	28480	1818-3464
A60U33	1818-3464	2			IC EPROM 2K X8	28480	1818-3464
A60U34					NOT ASSIGNED		
A60U35					NOT ASSIGNED		

A60 Processor Component-Level Troubleshooting

Table A60-7. A60 Processor Replaceable Parts

Reference Designation	HP Part Number	C D	Qty	Description	Mfr Code	Mfr Part Number
A60U36/37	08340-60249	8	2	PROGRAMMED 256K UVEPROM SET NOT SEPARATELY REPLACEABLE	28480	08340-60249
A60U38	1818-3183	2	2	IC CMOS 65536 (64K) STAT RAM 150-NS 3-S	28480	1818-3183
A60U39	1818-3183	2		IC CMOS 65536 (64K) STAT RAM 150-NS 3-S	28480	1818-3183
A60U40	1251-4787	2	1	SHUNT-DIP 8-POSITION	28480	1251-4787
A60VR1	1902-3107	9	1	DIODE-ZNR 5 76V 2% DO-35 PD= 4W	28480	1902-3107
A60X1	1200-0607	0	1	SOCKET-IC 16-CONT DIP DIP-SLDR	28480	1200-0607